

WC201250

V.2

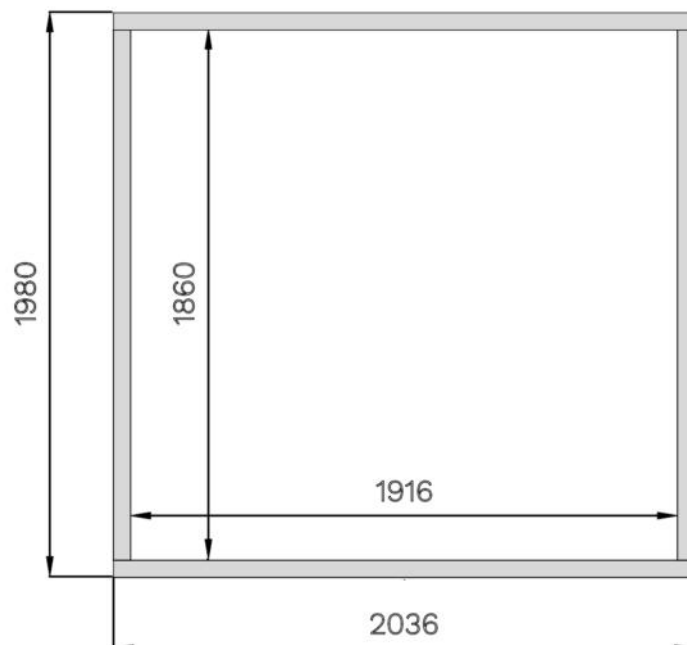
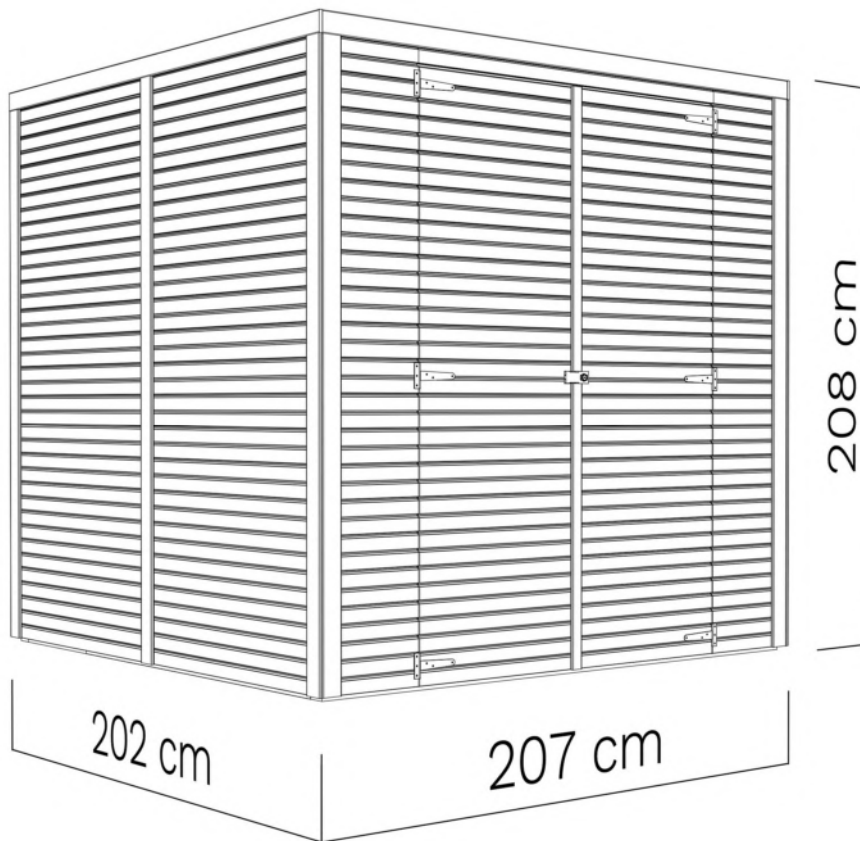

DE - Technische Änderungen vorbehalten.

Alle Maße sind ca. Maße.

EN - Technical modifications reserved.

All dimensions are approximate dimensions.

WC201250

DE **Bevor Sie beginnen**

• Es ist empfehlenswert sich etwas Zeit zu nehmen, um die Aufbauanleitung anzusehen, bevor mit dem Aufbau begonnen wird. • Alle Schritte für den Aufbau werden – auch in Detailbildern – dargestellt. • Die vorgegebene Reihenfolge ist zu beachten. • Bitte prüfen Sie vor dem Aufbau anhand der Teileliste die Vollständigkeit und den Zustand der Lieferung. • Besonders wichtig ist der Holzschutz! Die Boden-elemente sind vor dem Aufbau von unten mit einem geeigneten Holzschutz zu behandeln! • Das für die meisten Produkte online verfügbare Datenblatt bietet weitere wichtige Hinweise für den Aufbau. • Beigefügt sind auch die Garantiebedingungen.

FR **Avant de commencer**

• il est recommandé de prendre le temps de lire les instructions de montage avant de commencer. • Toutes les étapes du montage sont présentées, y compris sur des illustrations détaillées. • L'ordre prescrit doit être respecté. • Avant le montage, vérifier l'exhaustivité et l'état de la livraison à l'aide de la liste des pièces. • La protection du bois est particulièrement importante! Avant le montage, les éléments de plancher doivent être traités par le bas avec un produit de protection du bois approprié! • La fiche technique disponible en ligne pour la plupart des produits fournit d'autres informations importantes pour le montage. • Les conditions de garantie y sont également jointes.

CZ **Než začnete**

• Dporučujeme, abyste si vzali trochu času k prohlédnutí montážního návodu, než s montáží začnete. • Všechny montážní kroky jsou zobrazeny - také na podrobných obrázcích. • Je nutné dodržovat uvedený postup. • Před montáží zkontrolujte podle seznamu dílů, zda jste obdrželi všechny díly a zda je dodávka v dobrém stavu. • Obzvláště důležitá je dřevěná botka! Podlahové prvky musí být před montáží zespoda ošetřeny vhodným ochranným přípravkem na dřevo! • Datový list, který je k dispozici online pro většinu produktů, poskytuje další důležité pokyny k montáži. • V příloze naleznete také záruční podmínky.

DK **Før du starter**

• Det kan anbefales at tage sig tid til at kigge på samlevejledningen, før du starter samlingen. • Alle trin i samlingen bliver vist – også i detaljerede billeder. • Overhold den angivne rækkefølge. • Kontrollér, at leveringen er fuldstændig og i den rette tilstand ved hjælp af delelisten, før du starter samlingen. • Særligt vigtig er træbeskyttelsen! Gulvelementerne skal behandles med egnet træbeskyttelse nedefra, før du starter samlingen! • Til de fleste produkter kan du finde datablade online, der indeholder yderligere vigtige informationer til samlingen. • Garantibetingelserne er også vedlagt.

NL **Voordat u begint**

• Het is aan te bevelen om de tijd te nemen om de opbouwhandleiding door te nemen voordat er met het opbouwen wordt begonnen. • Alle stappen voor het opbouwen worden - ook met gedetailleerde afbeeldingen - weergegeven. • Neem de aangegeven volgorde in acht. • Controleer voor het opbouwen aan de hand van de onderdelenlijst de volledigheid en de hoedanigheid van de levering. • Bijzonder belangrijk is de bescherming van het hout! De vloerelementen moeten voor het opbouwen van anderen met een geschikt houtbeschermingsmiddel worden behandeld! • Het voor de meeste producten online beschikbare gegevensblad bevat verdere belangrijke aanwijzingen voor de opbouw. • Bijgevoegd zijn ook de garantiebepalingen.

PL **Przed rozpoczęciem**

• Wskazane jest, aby przed przystąpieniem do montażu zapoznać się z instrukcją montażu. • Pokazane są wszystkie etapy montażu – również na szczegółowych zdjęciach. • Należy przestrzegać podanej kolejności. • Przed montażem należy skorzystać z listy części, aby sprawdzić, czy dostawa jest kompletna i w dobrym stanie. • Ochrona drewna jest szczególnie ważna! Przed montażem elementy podłogowe należy zabezpieczyć od dołu odpowiednim środkiem do konserwacji drewna! • Arkusz danych, który jest dostępny online dla większości produktów, zawiera dalsze ważne informacje dotyczące montażu. • Załączone są również warunki gwarancji.

SV **Innan du börjar**

• Vi rekommenderar att du åsidosätter lite tid för att titta igenom monteringsanvisningen innan du påbörjar monteringen. • Alla monteringsstegen visas – även med detaljerade bilder. • Den angivna ordningen måste följas. • Kontrollera att leveransen är komplett och i gott skick innan monteringen påbörjas med hjälp av listan över delar. • Träskyddet är av yttersta vikt! Golvelementen ska behandlas underifrån med lämpligt träskyddsmedel före monteringen! • Annan viktig information före montering finns i databladet (tillgängligt online för de flesta produkter). • Garantivillkoren bifogas också.

RO **Înainte să începeți**

• Vă recomandăm să dedicați puțin timp pentru a consulta Instrucțiunile de asamblare înainte de a începe asamblarea. • Toate etapele de asamblare sunt prezentate amănunțit - și în forma unor figuri detaliate. • Respectați ordinea specificată. • Înainte de asamblare, vă rugăm să verificați lista de componente pentru a vă asigura că furnitura este completă și în stare bună. • Acordați o deosebită atenție protecției lemnului! Elementele de podea trebuie tratate de dedesubt cu o substanță conservantă adecvată pentru protecția lemnului înainte de asamblare! • Fișa de date, care este disponibilă și online pentru majoritatea produselor, oferă informații suplimentare importante cu privire la asamblare. • Atașat veți găsi și condițiile de garanție.











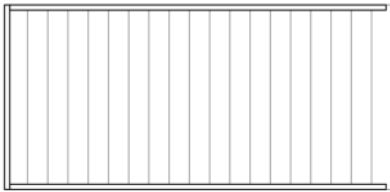
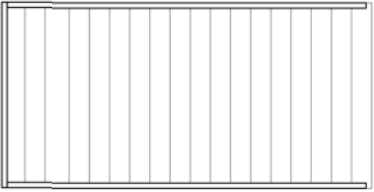
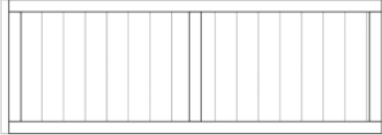

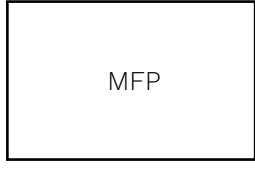

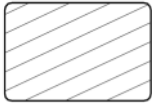

EE **Soovitused enne paigalduse alustamist**

• Soovitame enne paigalduse alustamist võtta aega ja tutvuda paigaldusjuhendiga. • Kõik kokkupaneku etapid on näidatud ka üksikasjalikel piltidel. • Paigaldustööd tuleks teha etteantud järjekorras. • Enne paigalduse alustamist kontrollige detailide nimekirja alusel, kas kõik elemendid on olemas ja ega need pole kahjustada saanud. • Puidukaitse on eriti oluline! Põrandaelemente tuleb enne kokkupanekut töödelda altpoolt sobiva puidukaitsevahendiga! • Andmeleht, mis on enamiku toodete kohta internetis saadaval, pakub kokkupanekuks täiendavat olulist teavet. • Lisatud on ka garantiitingimused.



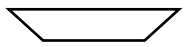













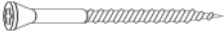

EN **Before assembly**

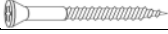
• We recommend that time is taken to read the assembly instructions prior to assembly. • All assembly steps are shown – also in detailed images. • The step-by-step instructions must be followed. • Before assembly, please use the parts list to check that all components are accounted for and in good condition. • Wood protection is particularly important! The floor elements must be treated from below with a suitable wood preservative before assembly! • The data sheet, which is available online for most products, offers further important information for assembly. • The guarantee conditions are also attached.

WC201250

ZID	Details in mm (Tolerance/Toleranz ...+ 2mm)	Pcs.	ID	Details in mm (Tolerance/Toleranz ...+ 2mm)	Pcs.
371	45 x 990 x 2064 	x 4	379	45 x 990 x 1956 	x 2
380	36 x 665 x 1930 	x 2	373	45 x 319 x 2064 	2
516	12 x 830 x 1150 Roof panel 	x 2	517	12 x 830 x 830 Roof panel 	x 2
1180	12 x 413 x 1150 Roof panel 	x 1	1203	12 x 413 x 830 Roof panel 	x 1
			1154	40 x 60 x 2036 	x 2
			1183	40 x 60 x 1980 	x 2
1184	40 x 60 x 1924 	x 6	1143	40 x 60 x 1860 	x 2
1162	28 x 80 x 1342 	x 2	1191	28 x 80 x 933 	x 4
1163	28 x 80 x 370  	x 8	1193	28 x 28 x 1400 	x 1
1194	28 x 28 x 1980 	x 1			

WC201250

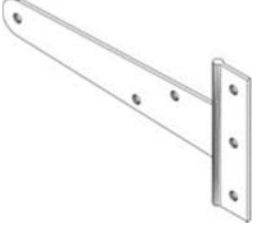
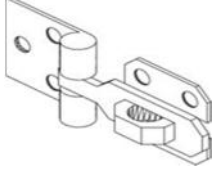
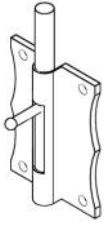
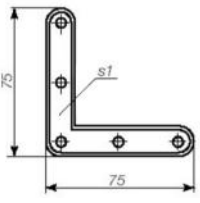
ID	Details in mm (Tolerance/Toleranz ...+ 2mm)	Pcs.	ID	Details in mm (Tolerance/Toleranz ...+ 2mm)	Pcs.
1196	19 x 60 x 999 	x 4	738	19 x 45 x 1655...1680 	x 4
717	19 x 45 x 360 	x 4	1197	12 x 70 x 1992 	x11
1202	12 x 70 x 1014 	x 4	1200	12 x 70 x 1049 	x 2
1175	12 x 42 x 1877 	x 2	1176	12 x 42 x 947 	x 2
1500	∅5 x 120 	x 19	1182	18 x 118 x 1342 	x 1
1502	∅4,5 x 75 	x 32	1501	∅4,5 x 90 	x 44
1506	∅3,5 x 35 	x117	1505	∅4,5 x 50 	x 147
1508	∅4 x 25 	x 9	1507	∅3,5 x 30 	x 66
			1510	∅3 x 19 	x 20
			1556	7 x 13 x 48 	x 1
1516		x 6	1518		x 1
1517		x 2	1562		x 4

NB!

Empfohlen bei Aufbau auf besonders feuchtem Untergrund. (**Nicht im Lieferumfang enthalten!**)

Recommended for assembly on moist ground. (***Not included!**)

* Unterlegpads /

* Patio Pads

Min. 8 lfm/rm



+€

Unterlegpads /
Patio pads



300 mm

Fundament

Der Untergrund / Ground

1.

Holzschutzmittel /
Wood preservative



4 mm



120 mm x 8 St

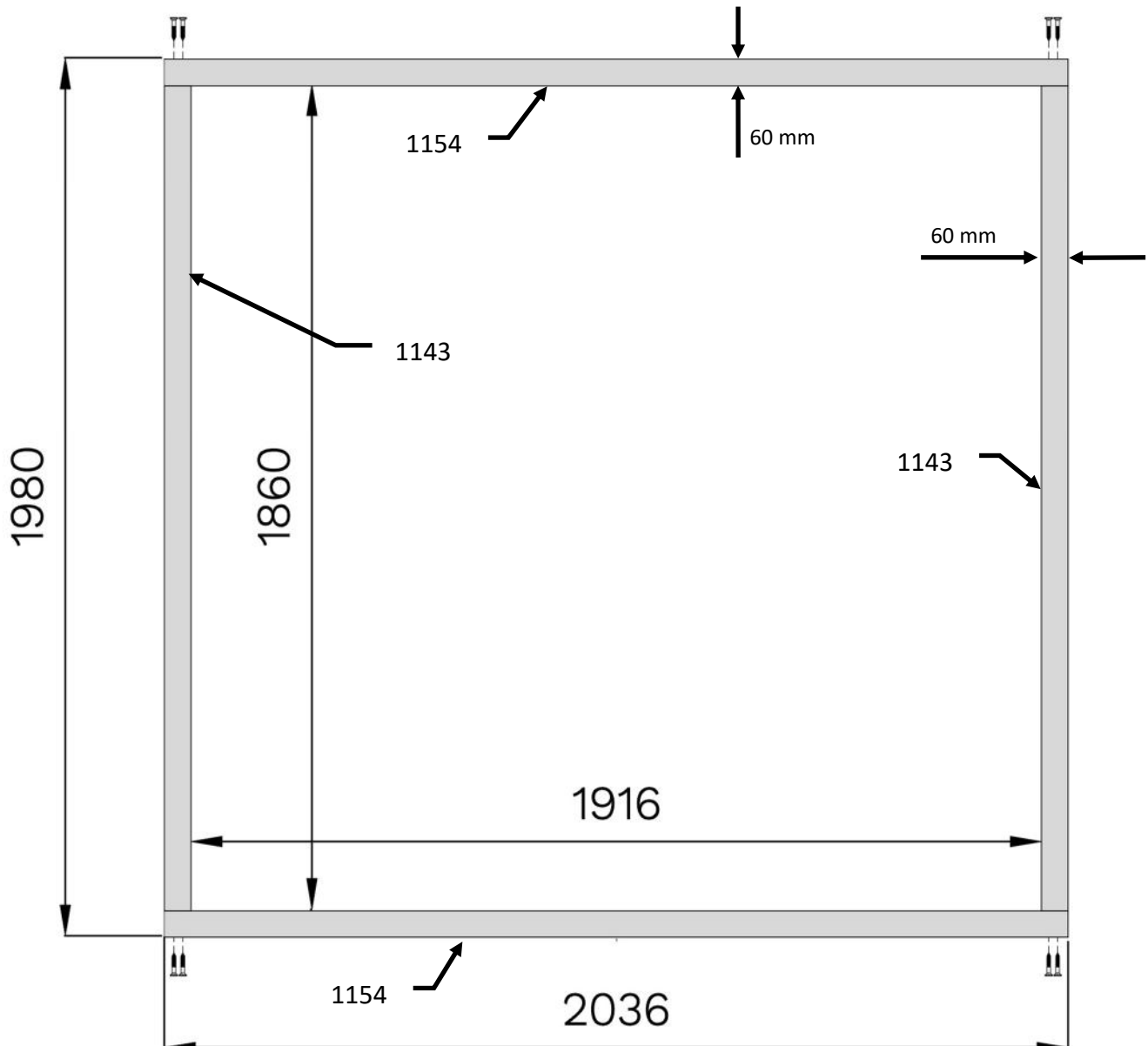

WC201250

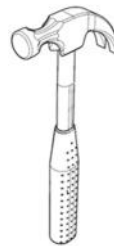
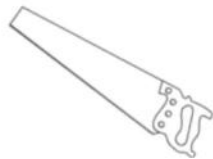
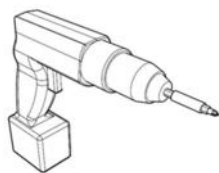

Ø 4 mm

Ø 8 mm

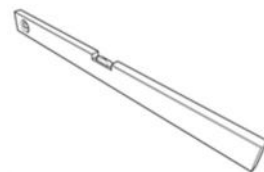

2.

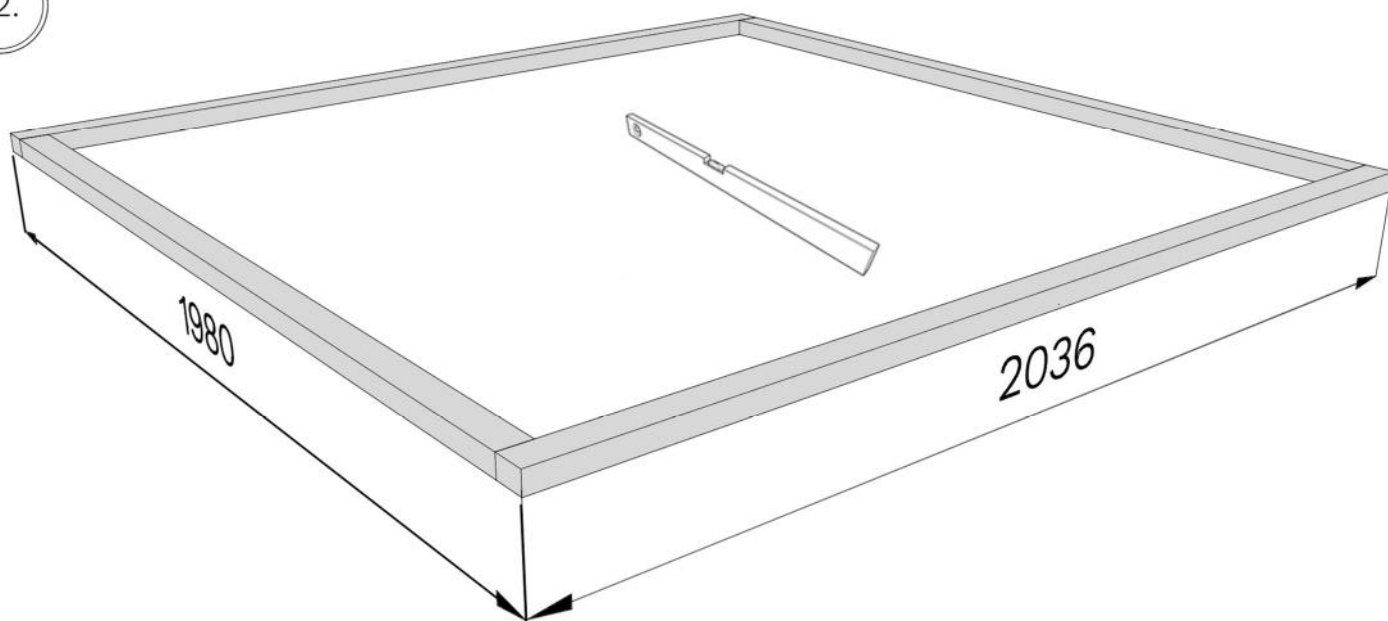

3.

371

379

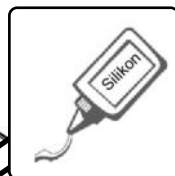

3.1

379

371

4 mm



50 mm x 4 St



WC201250

4.

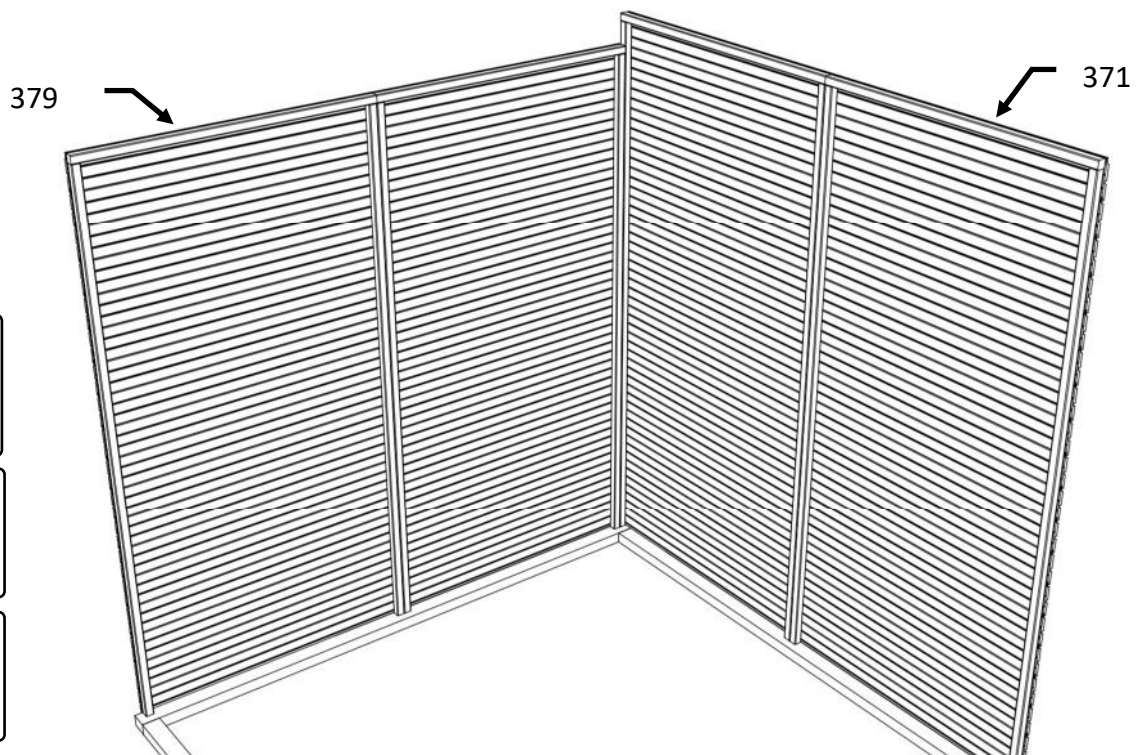

4 mm



50 mm x 8 St



5.

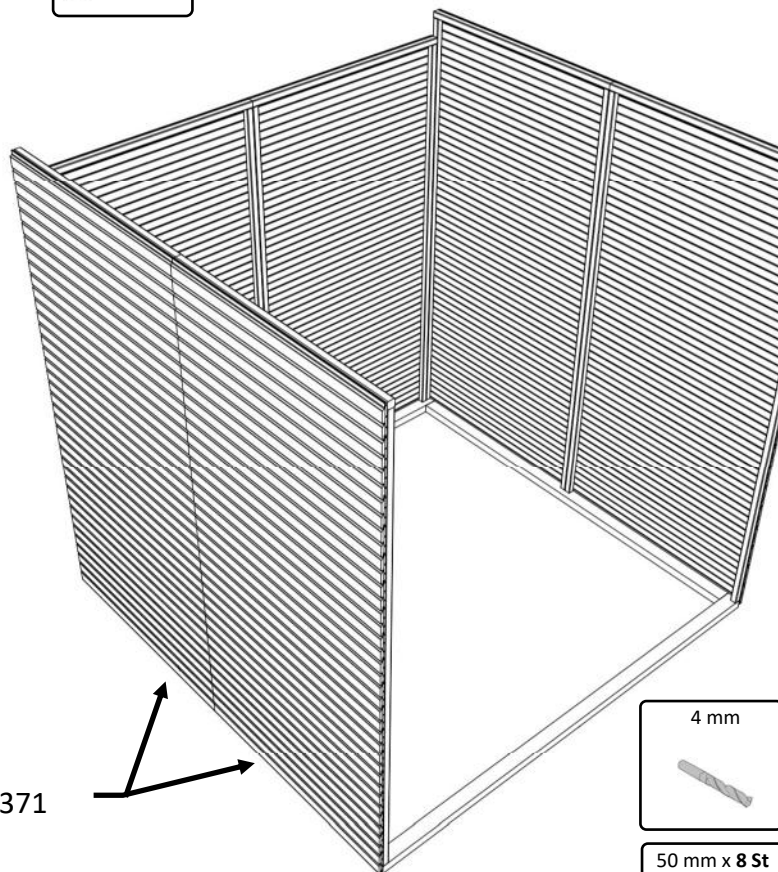
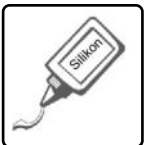

371

4 mm



50 mm x 8 St



6.



4 mm



50 mm x 8 St

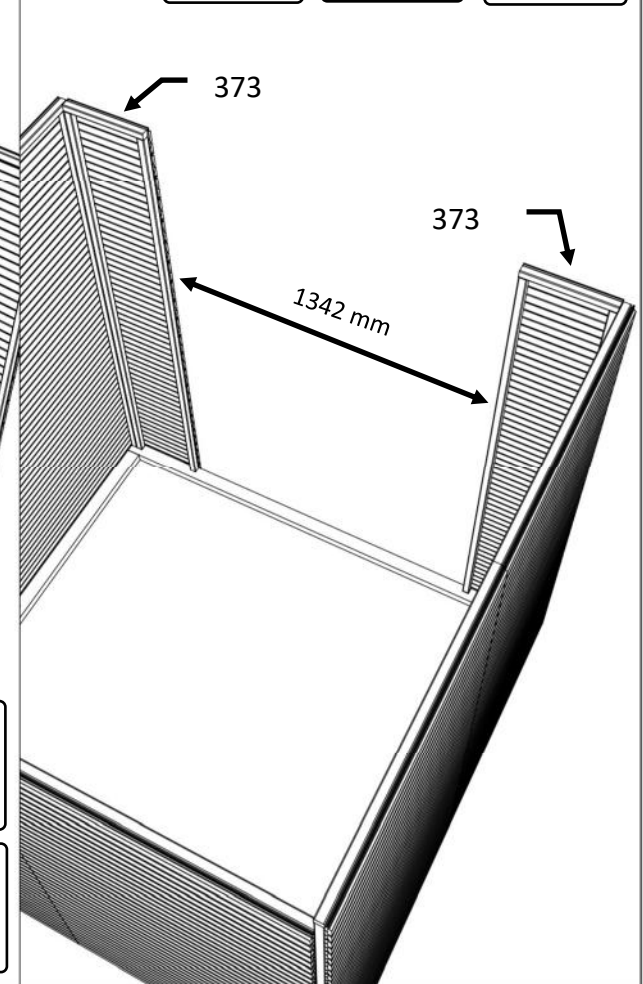

373

373

1342 mm

WC201250

7.

4 mm



50 mm x 16 St

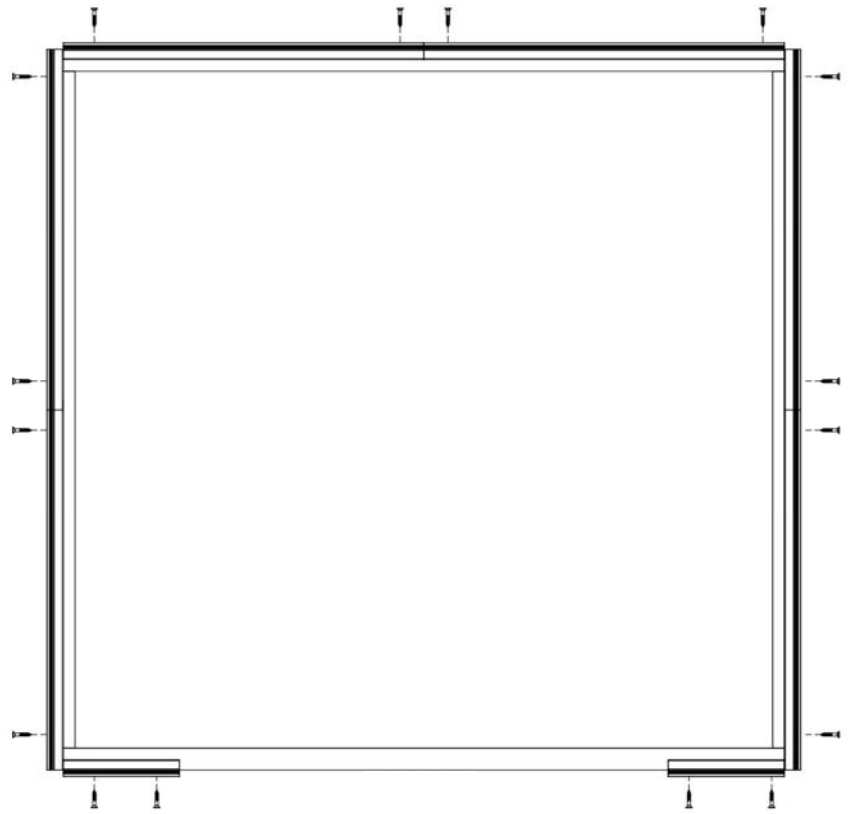
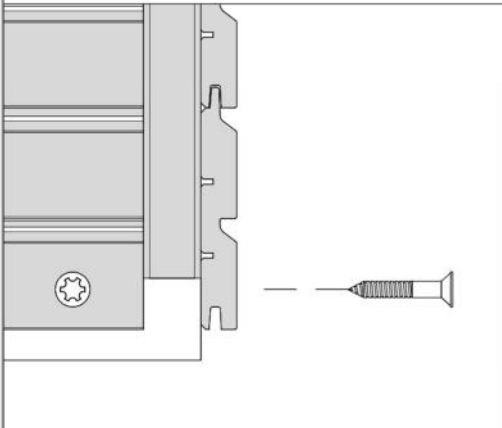

8.

4 mm



70 mm x 16 St

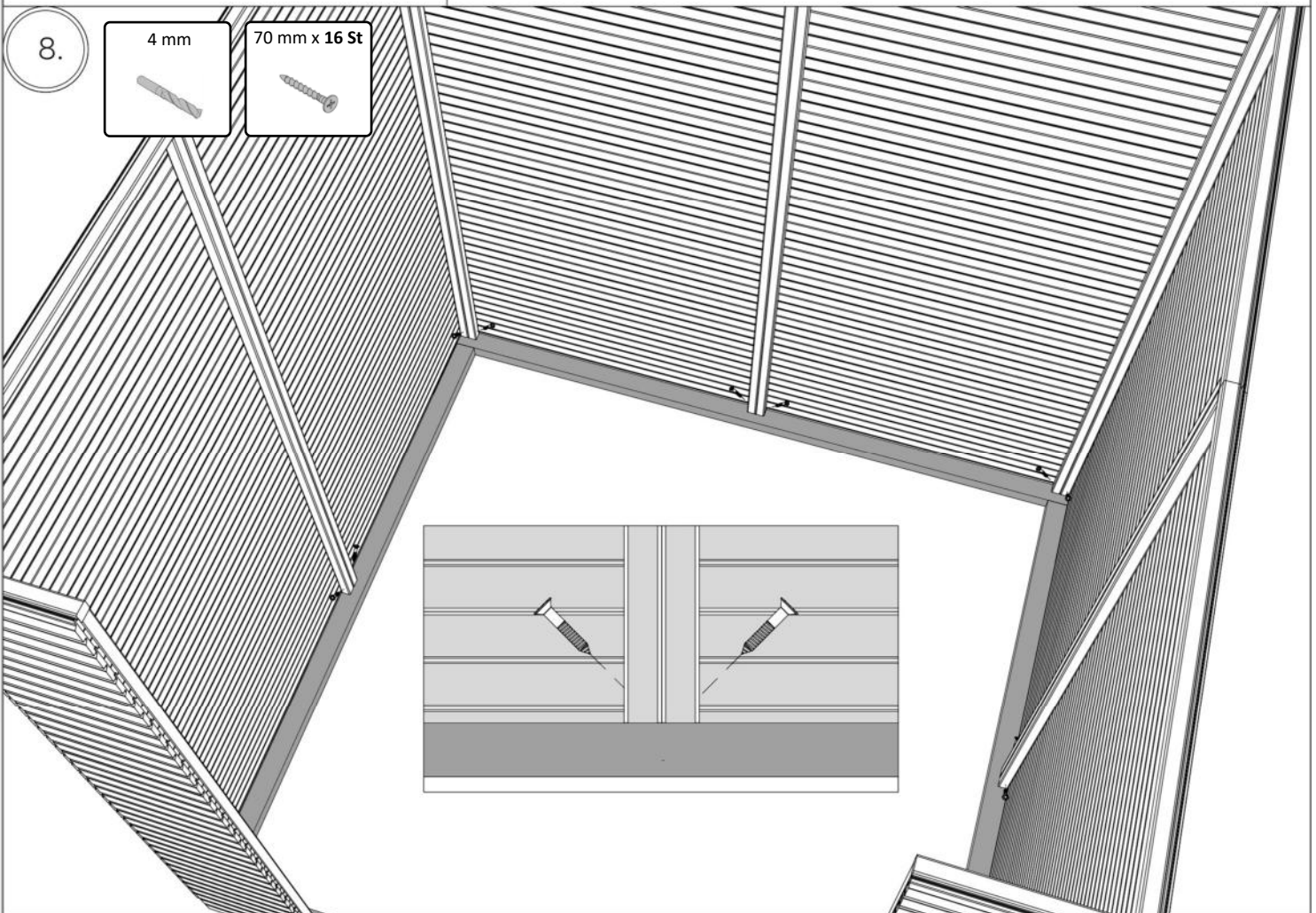

WC201250

9.

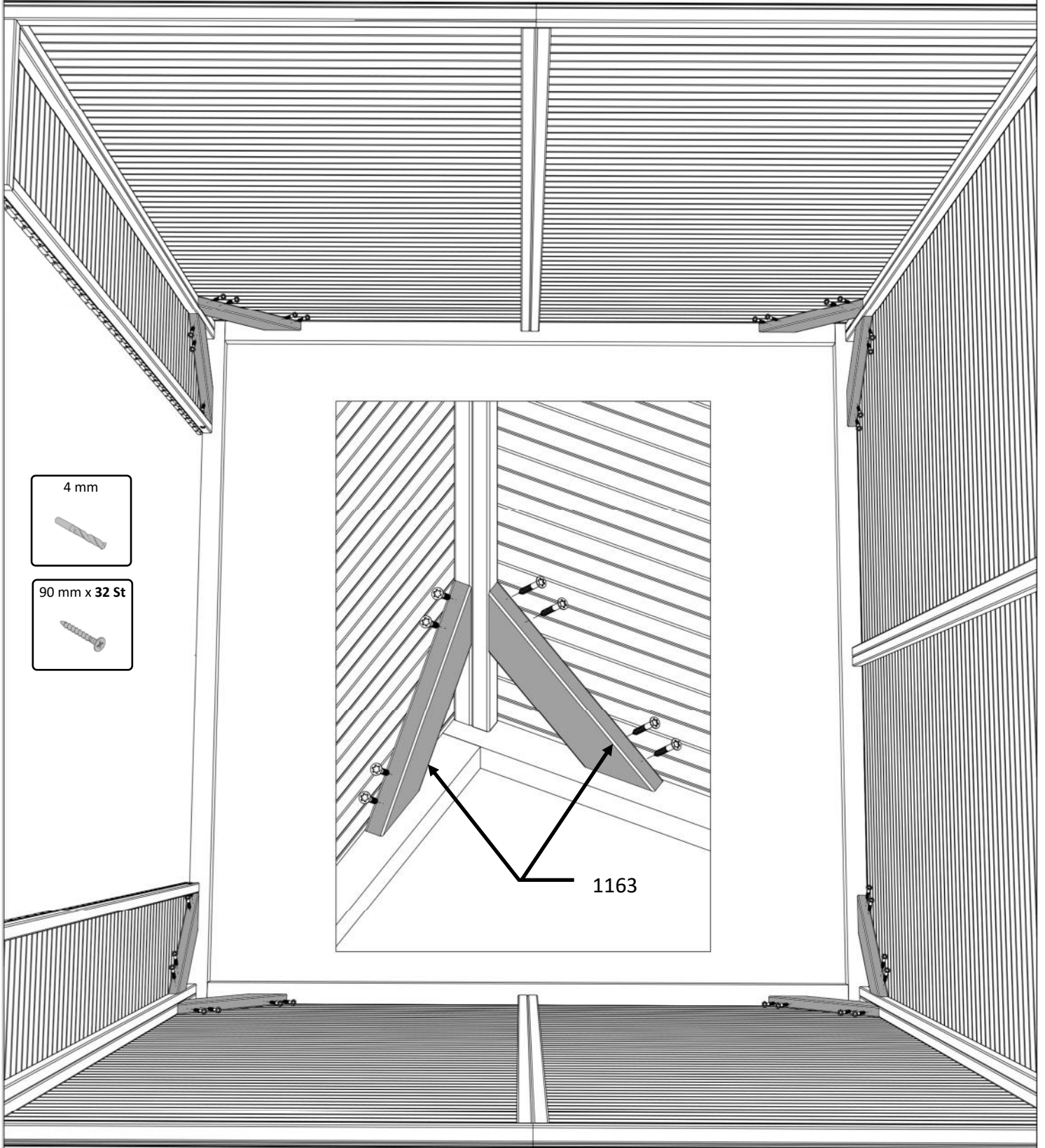

4 mm



90 mm x 32 St



1163

WC201250

10.

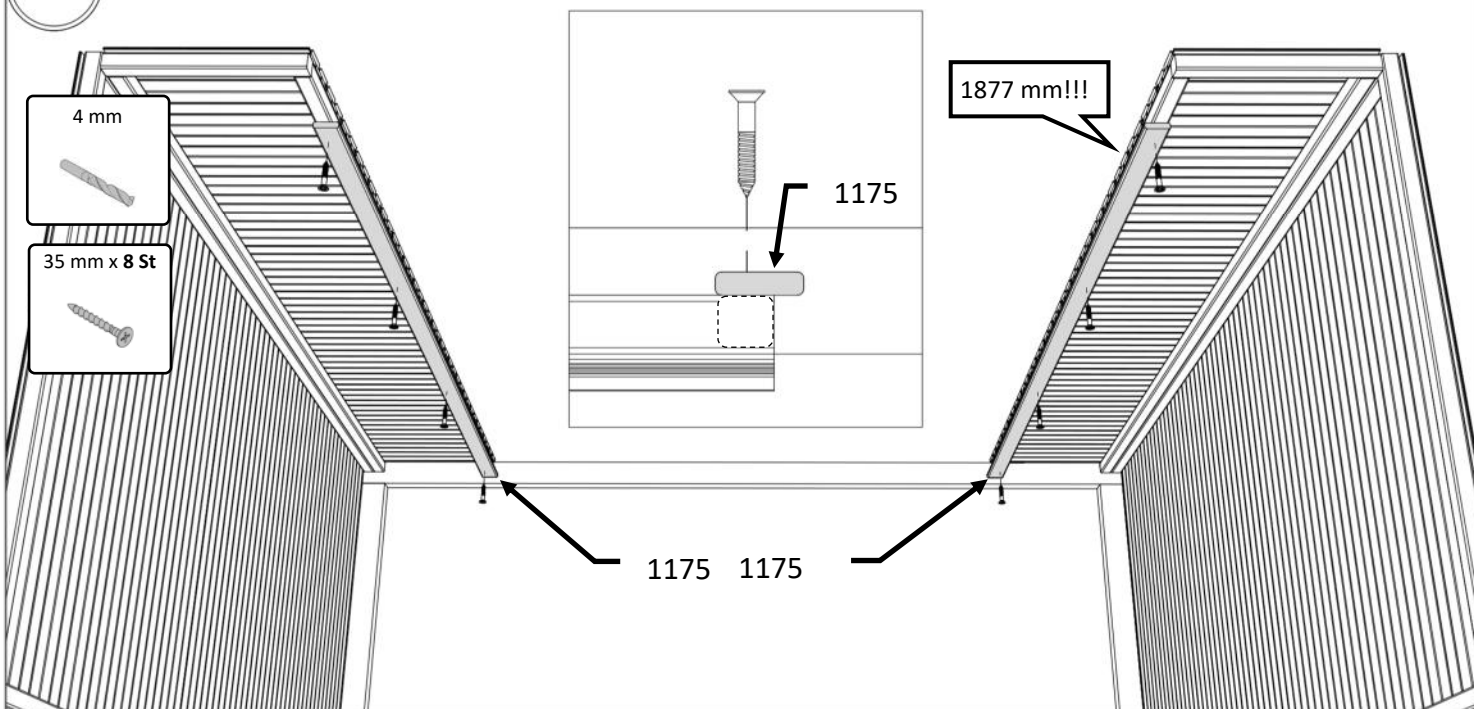

11.

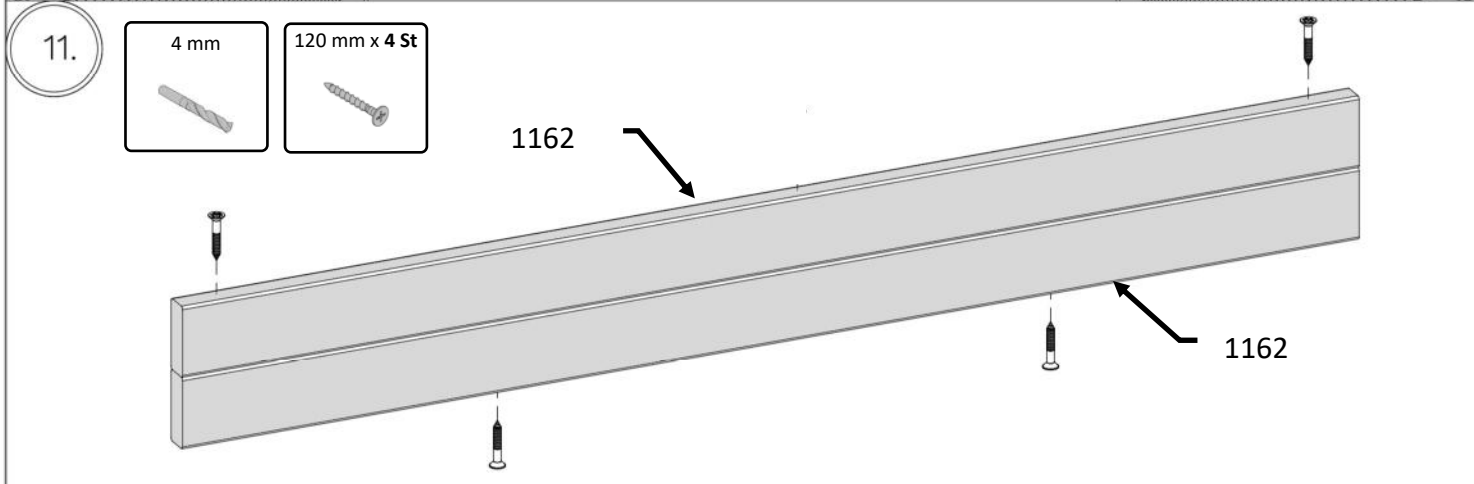

12.

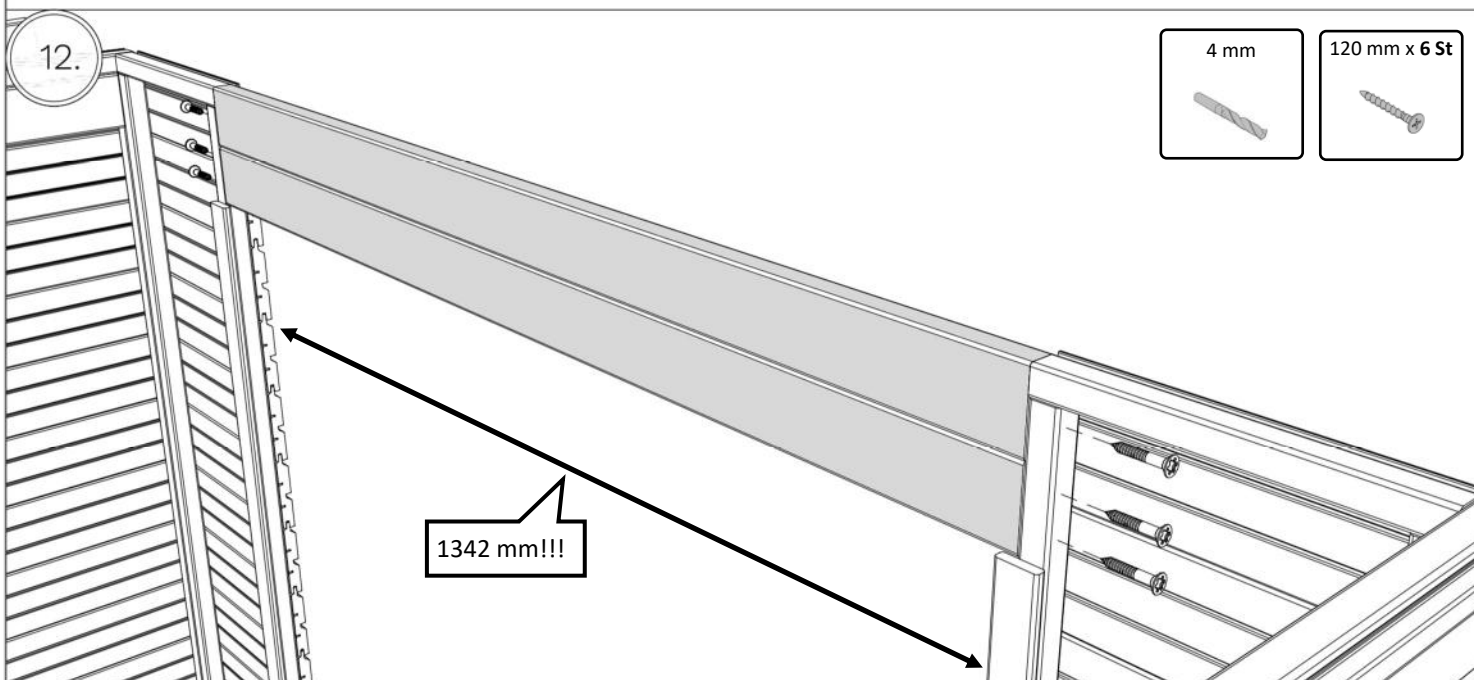

WC201250

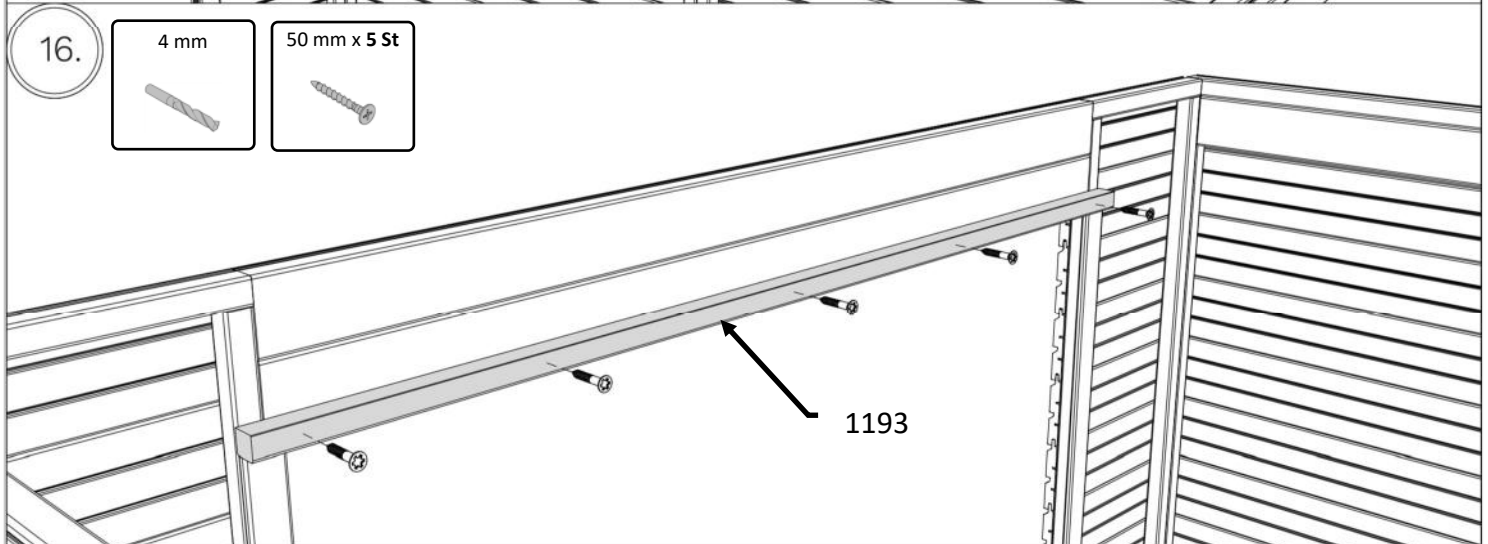
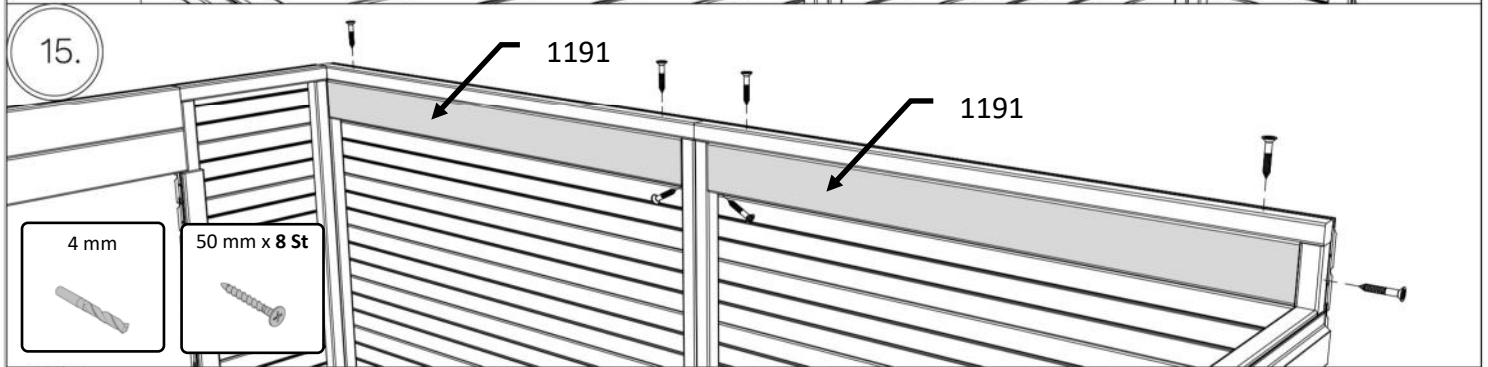
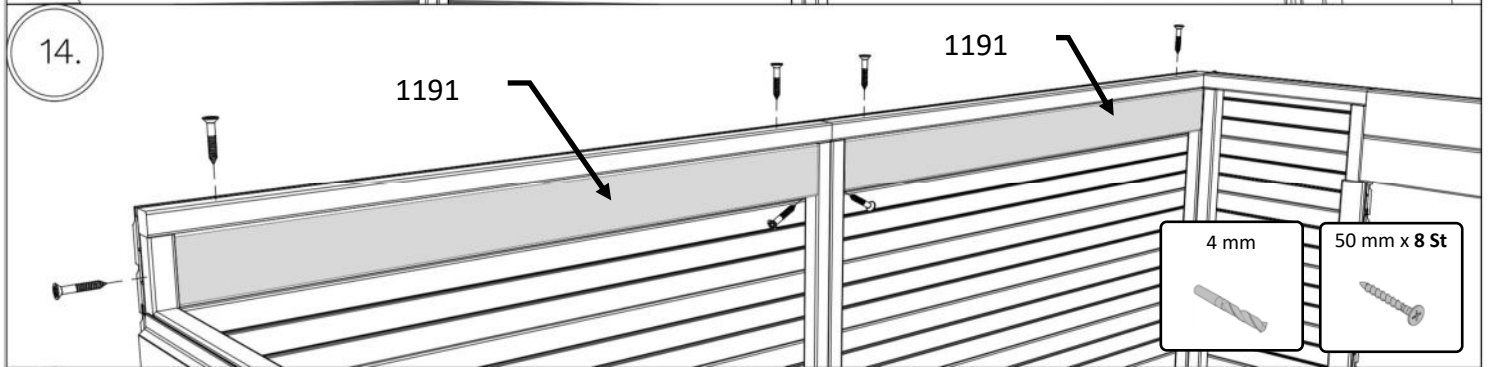
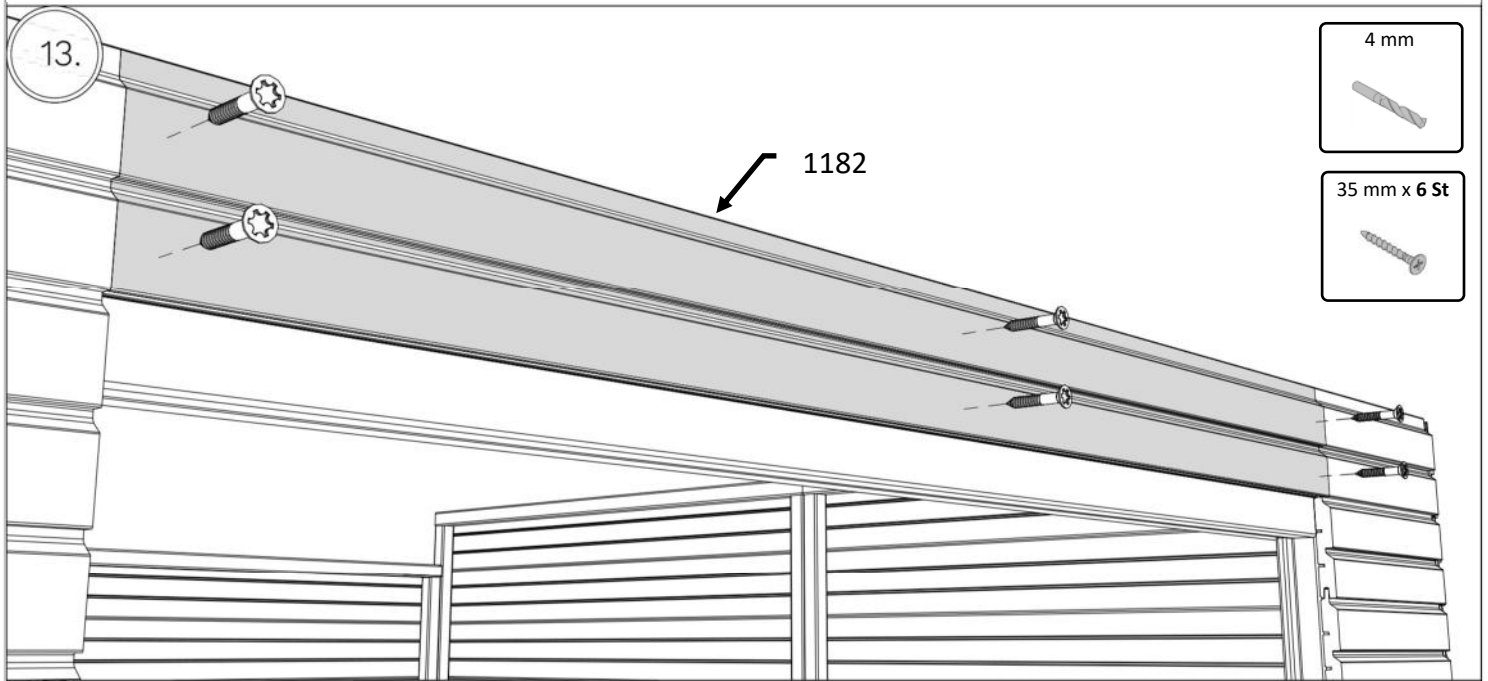

WC201250

17.

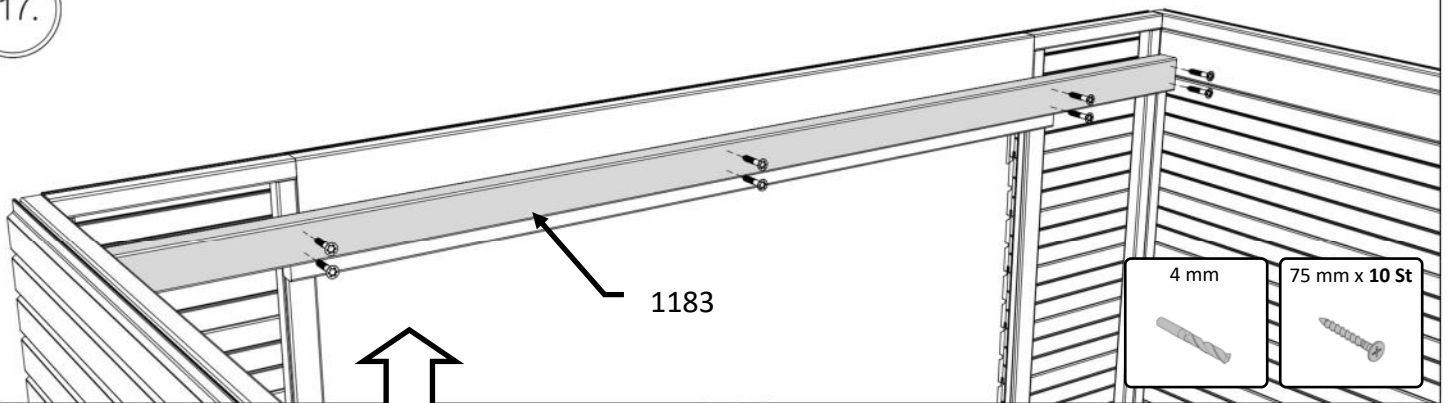

17.1

18.1

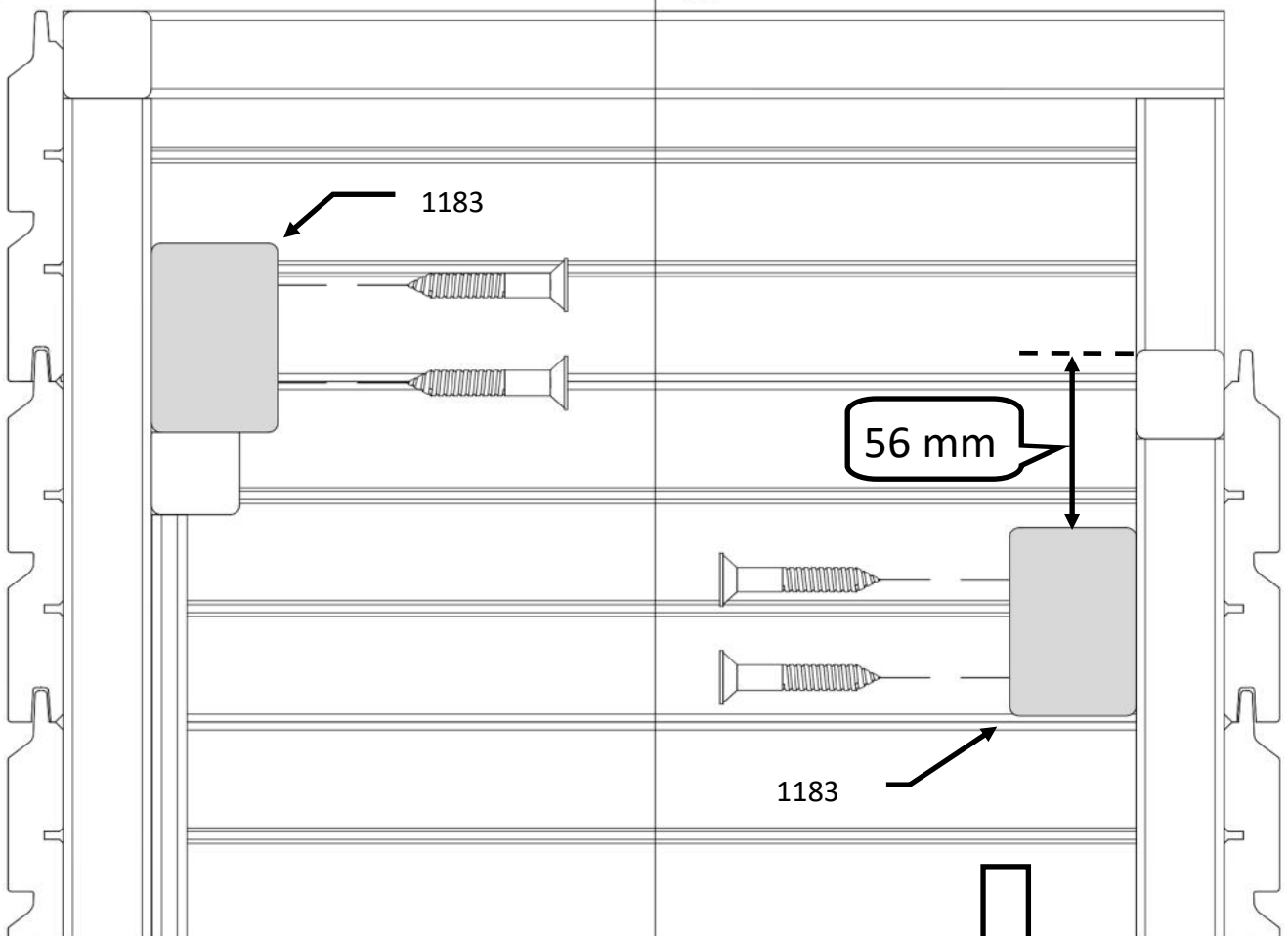

18.

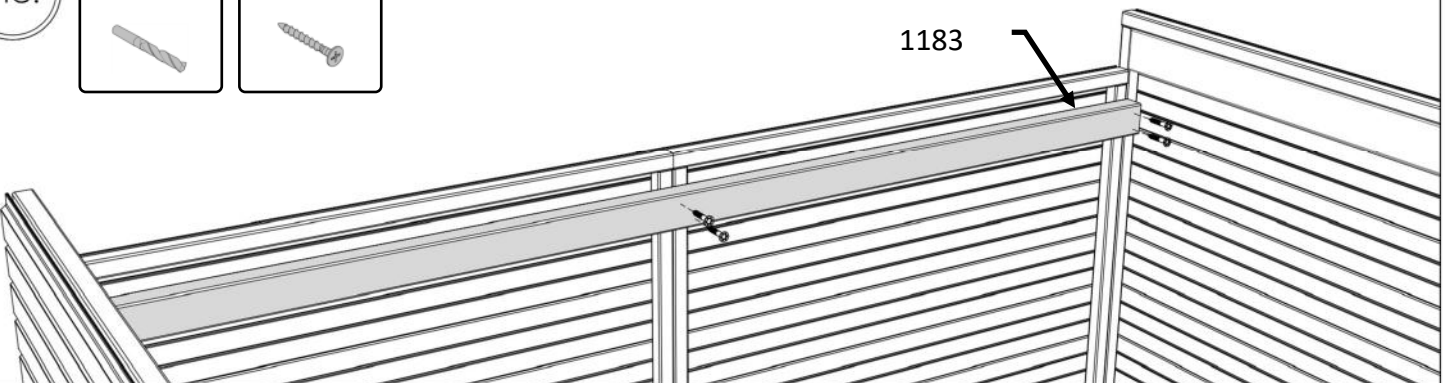
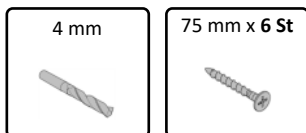

WC201250

19.

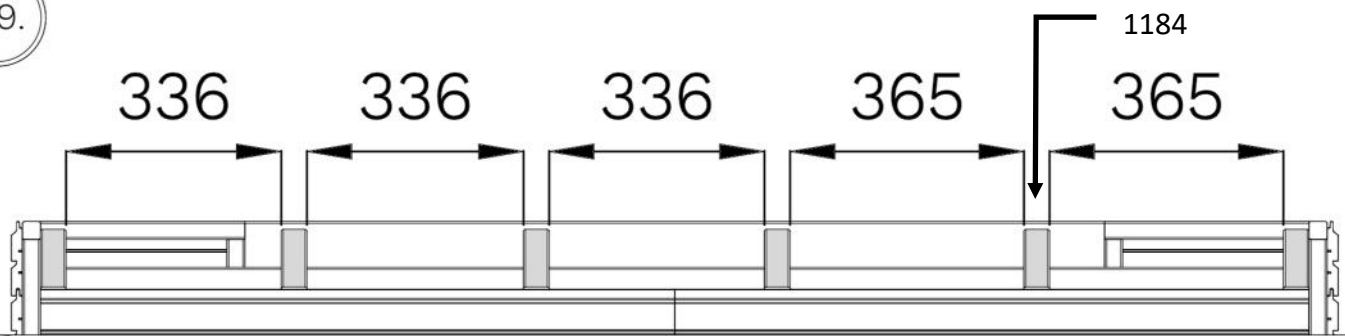

19.1

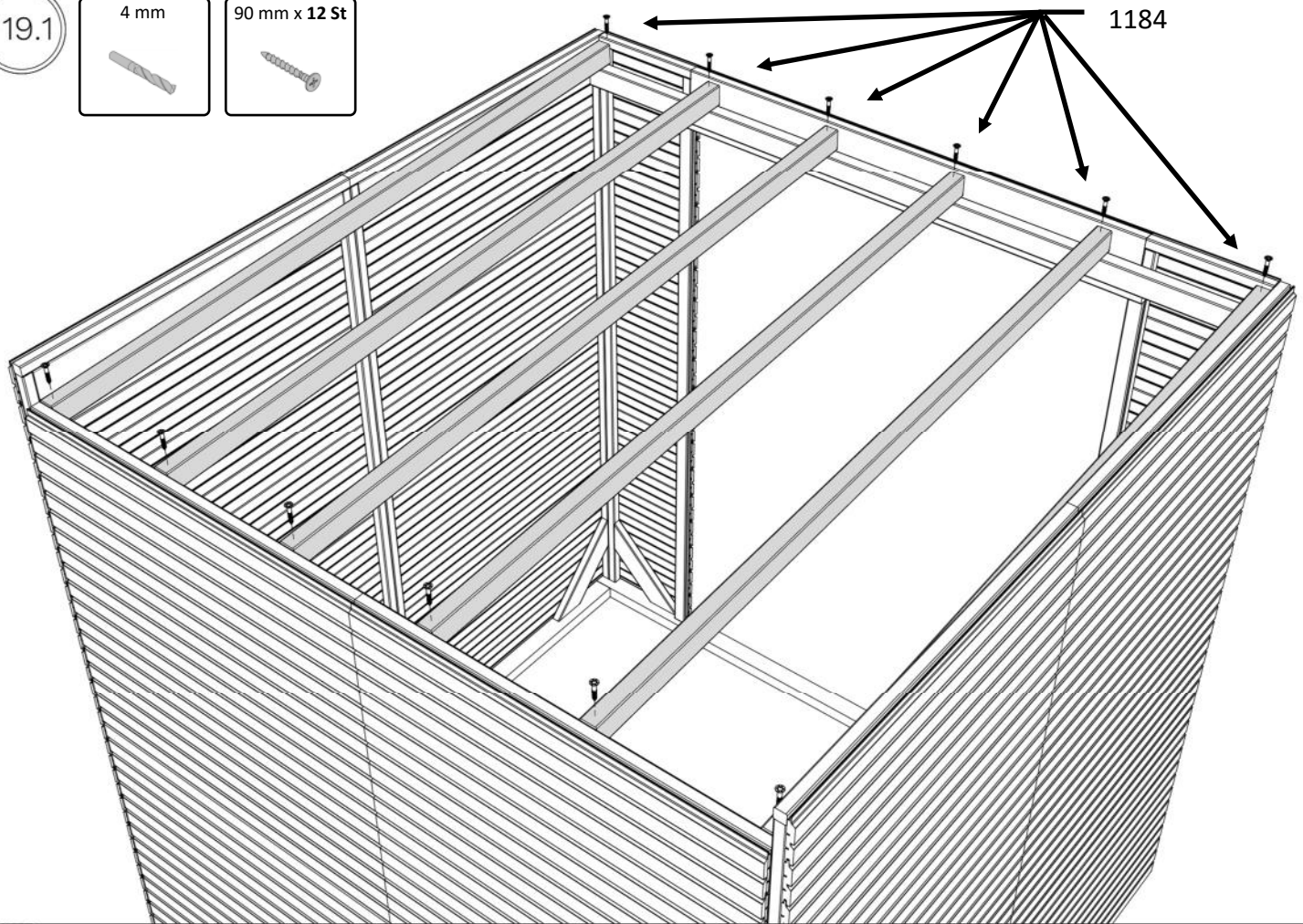
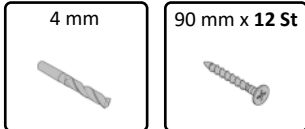

20.

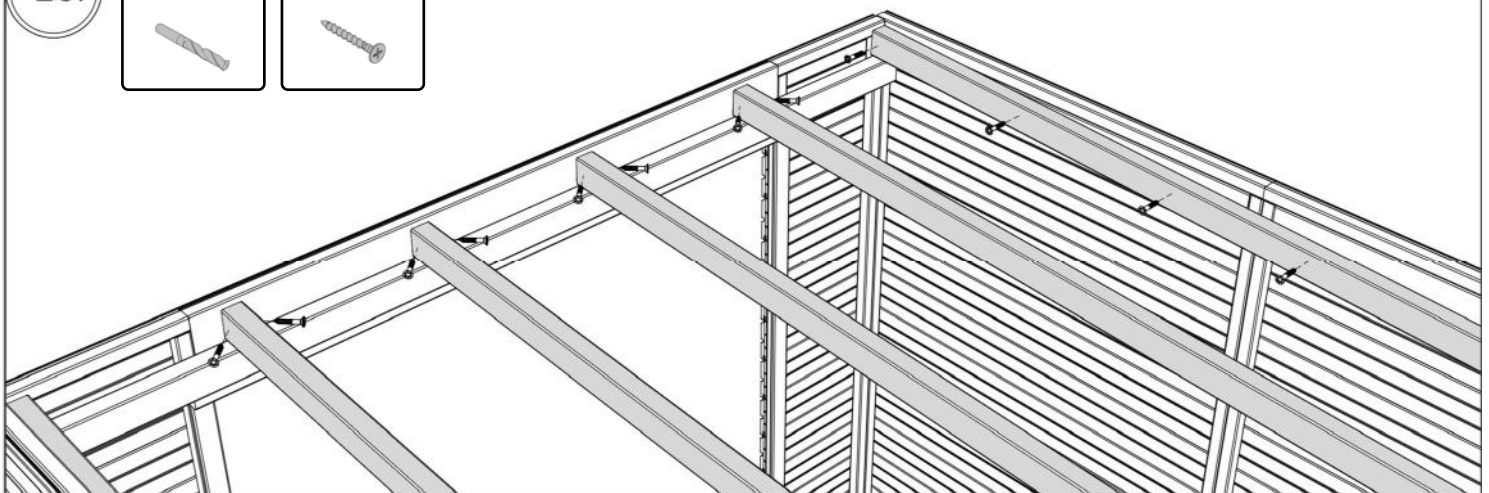
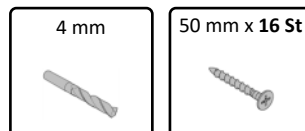

WC201250

21.

4 mm



50 mm x 10 St

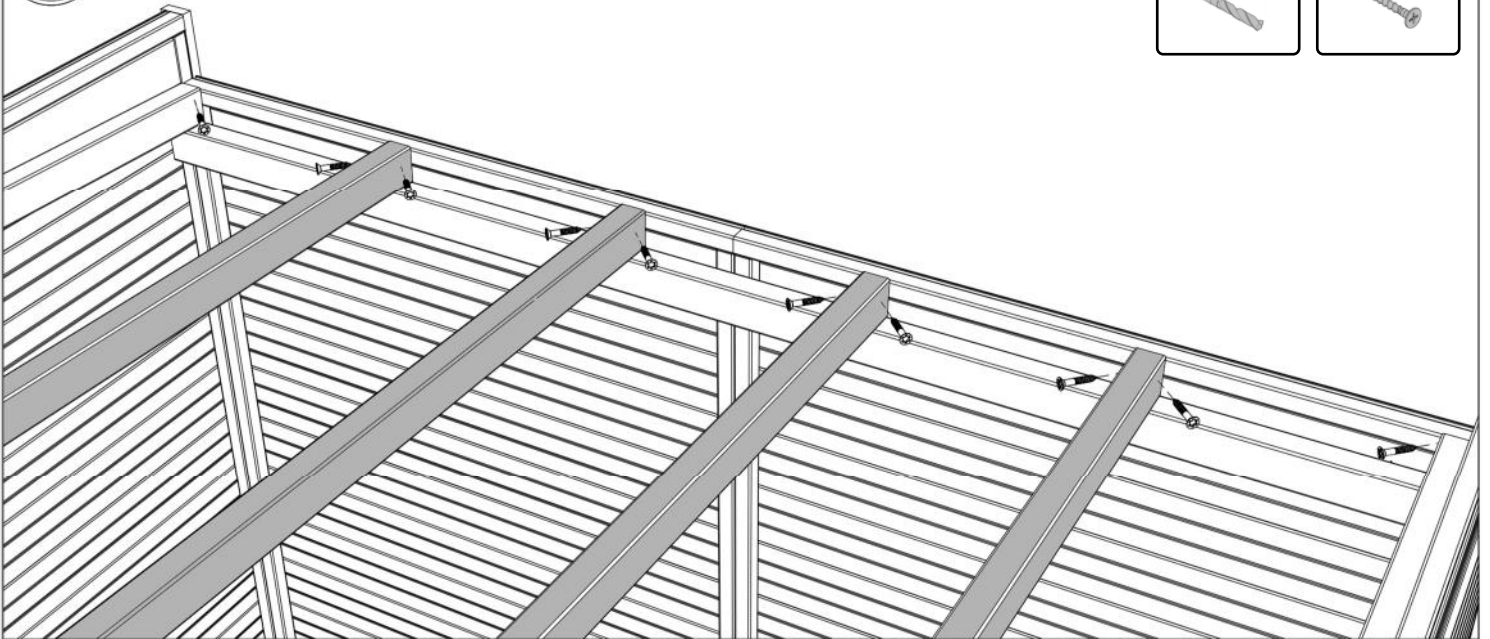

22.

516

517

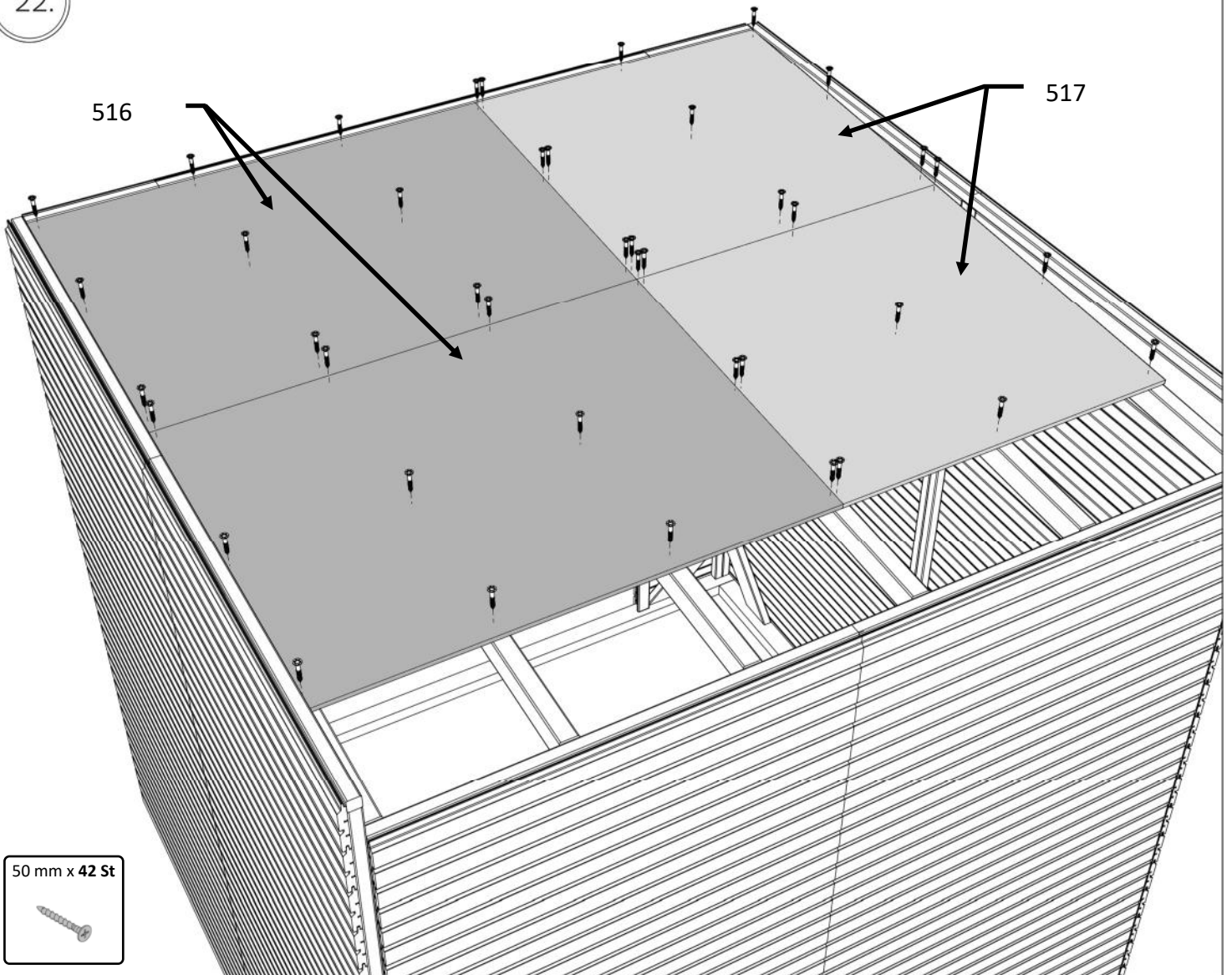

50 mm x 42 St



WC201250

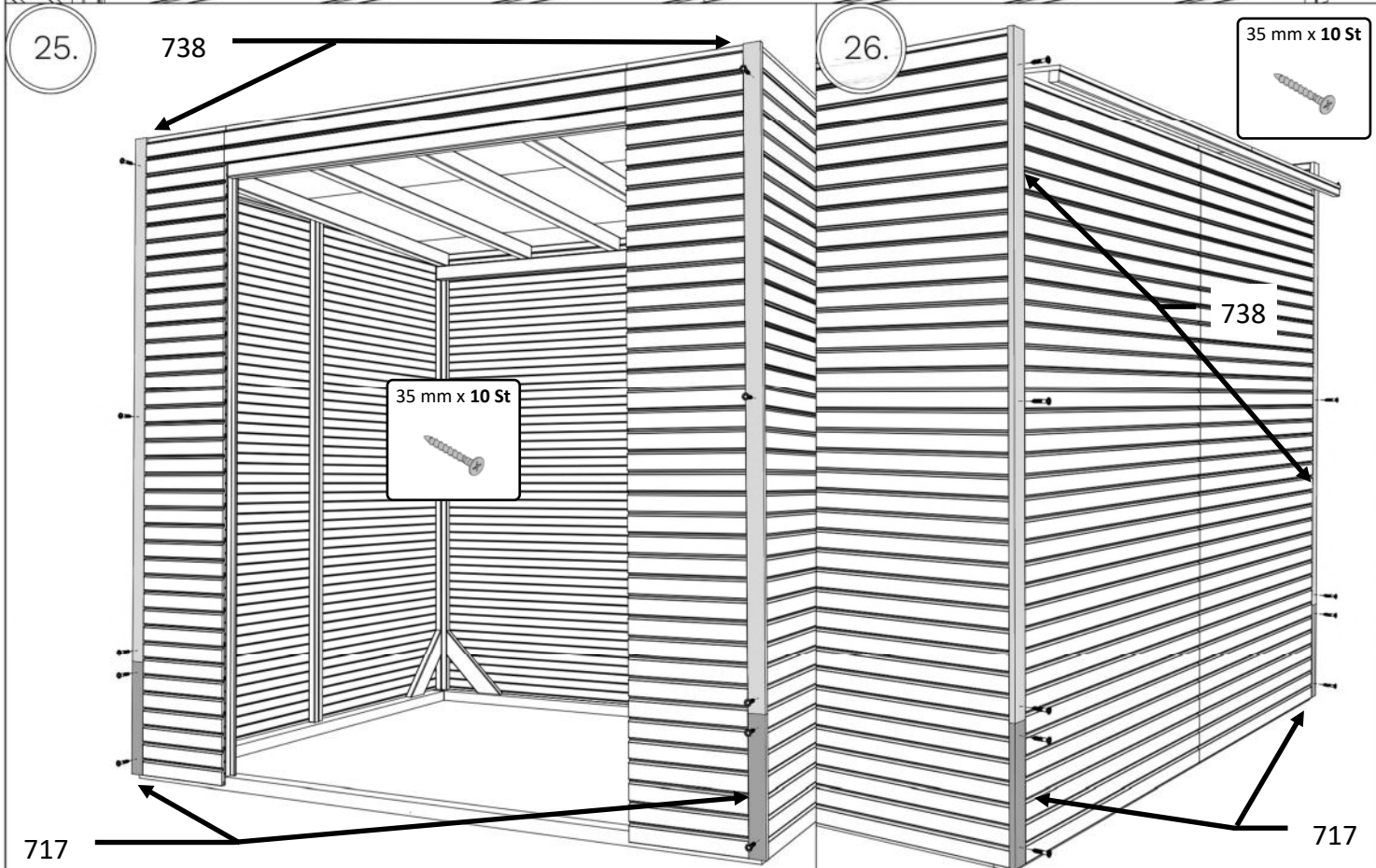
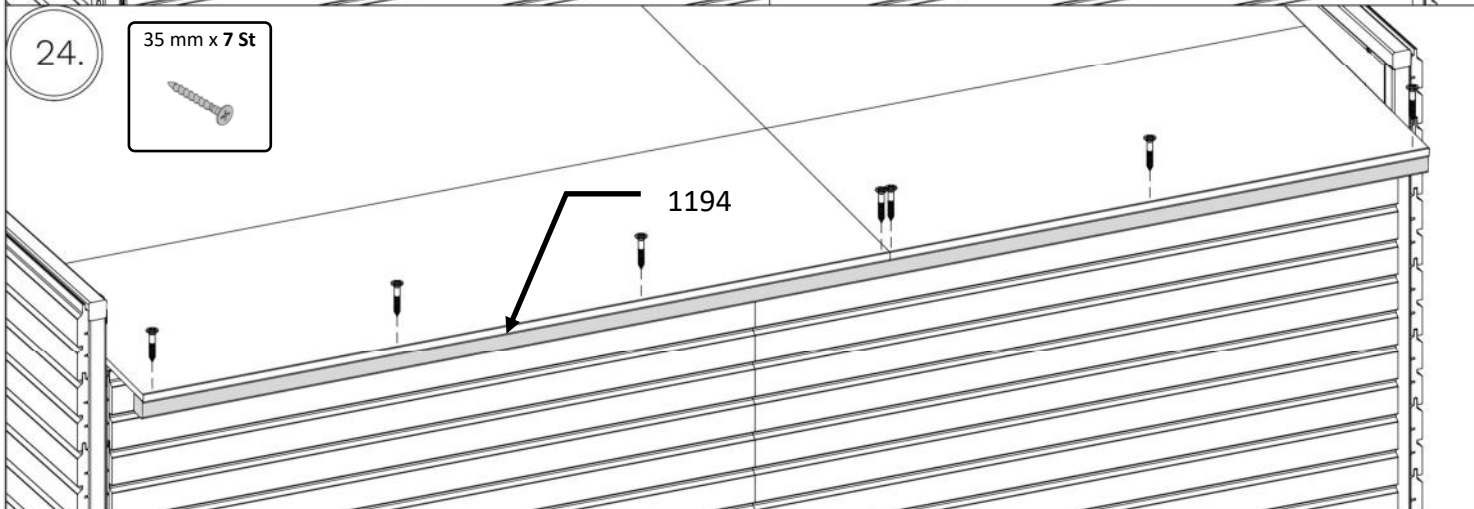
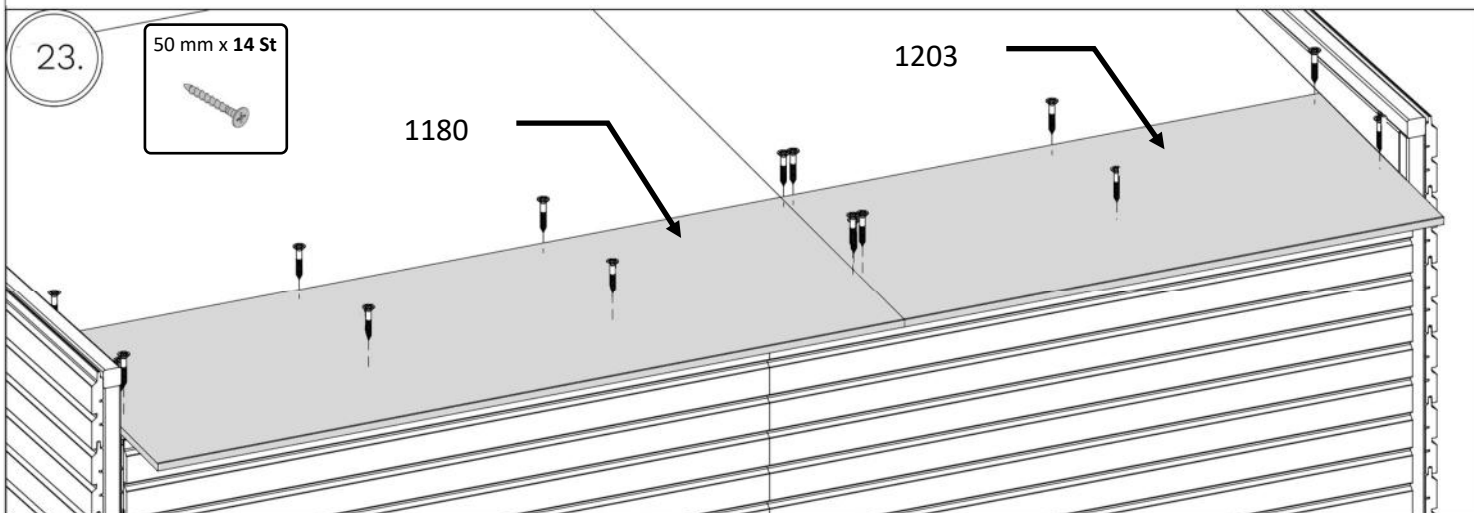

WC201250

27.

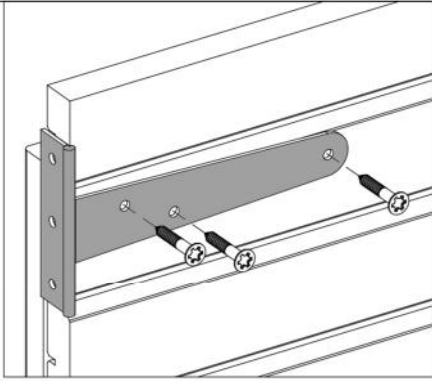

30 mm x 24 St



27.1

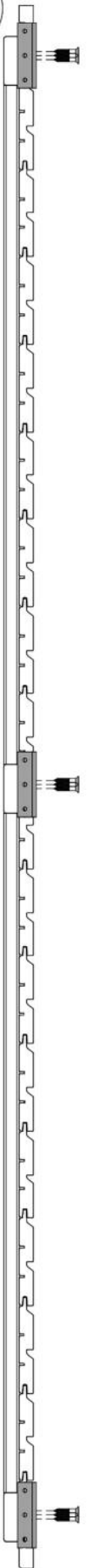

380

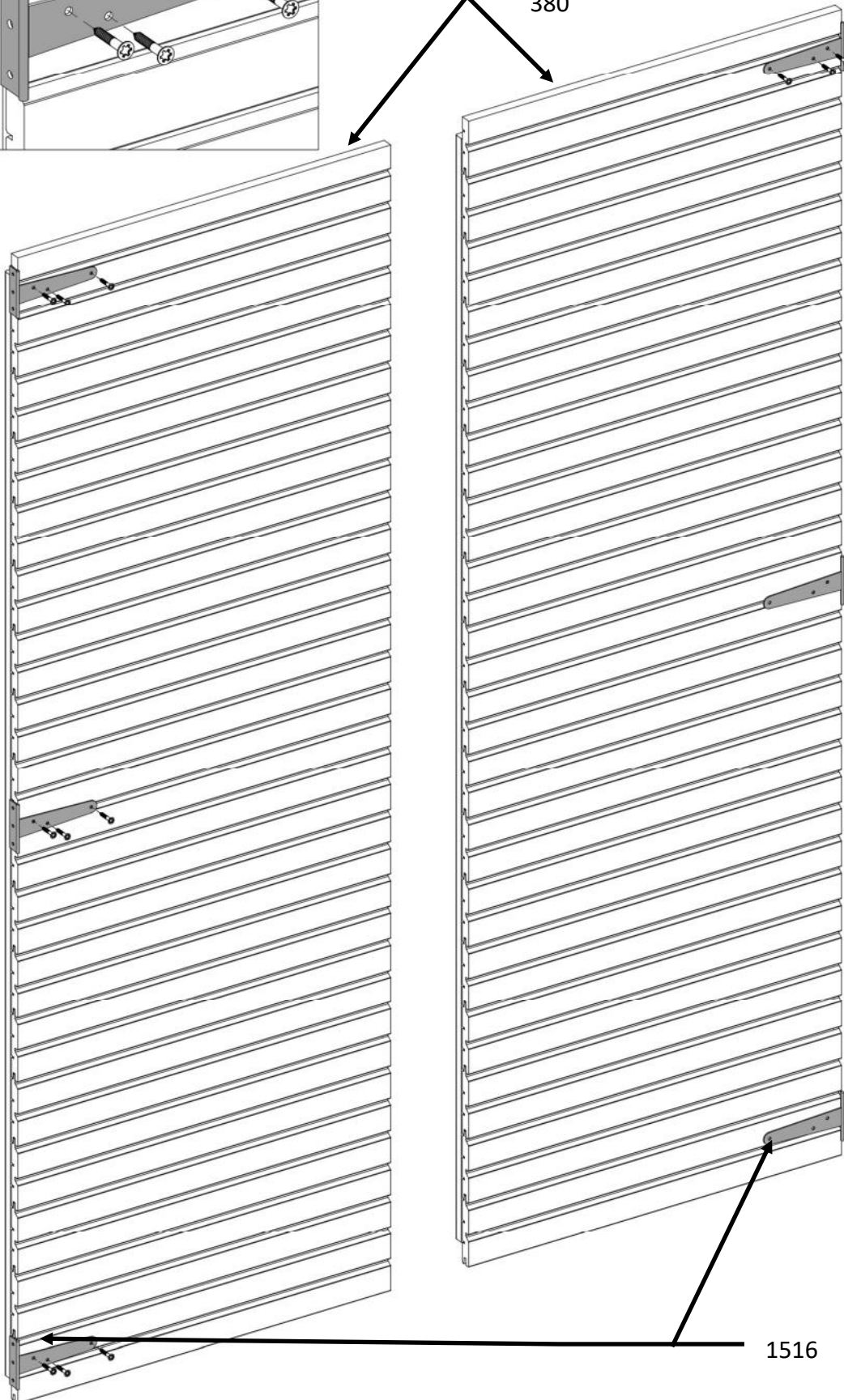

1516

WC201250

28.

1196

30 mm x 24 St

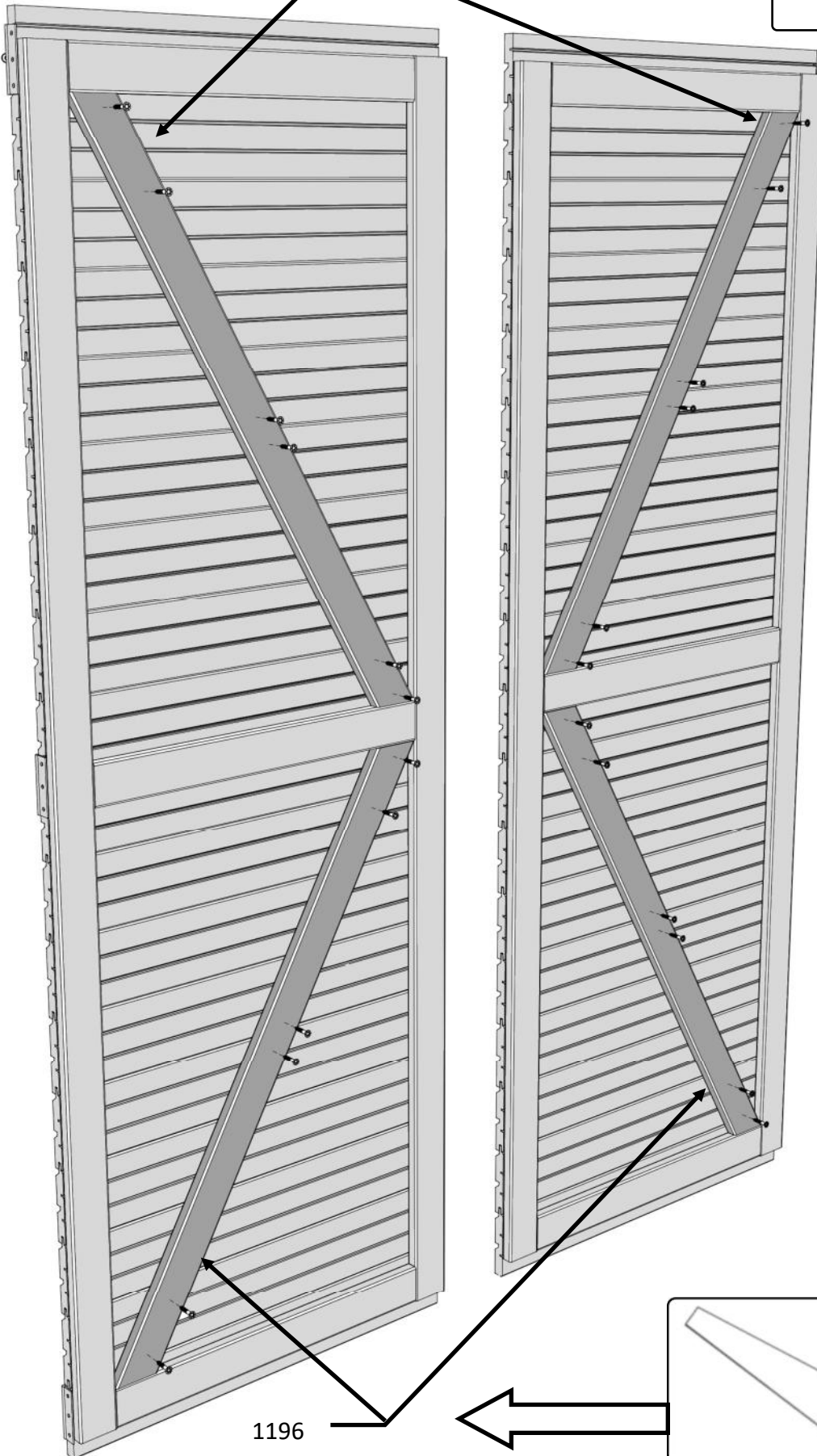

1196

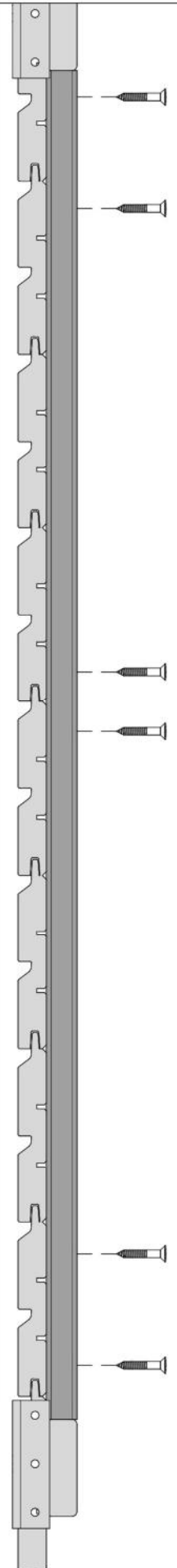
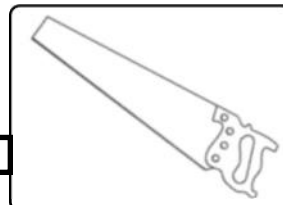

WC201250

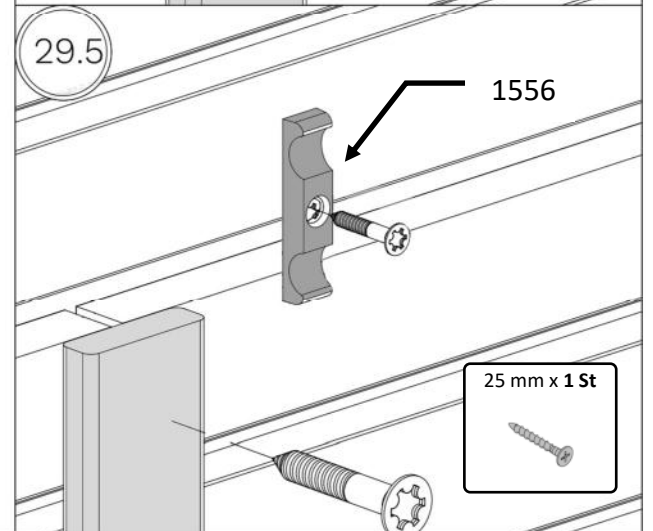
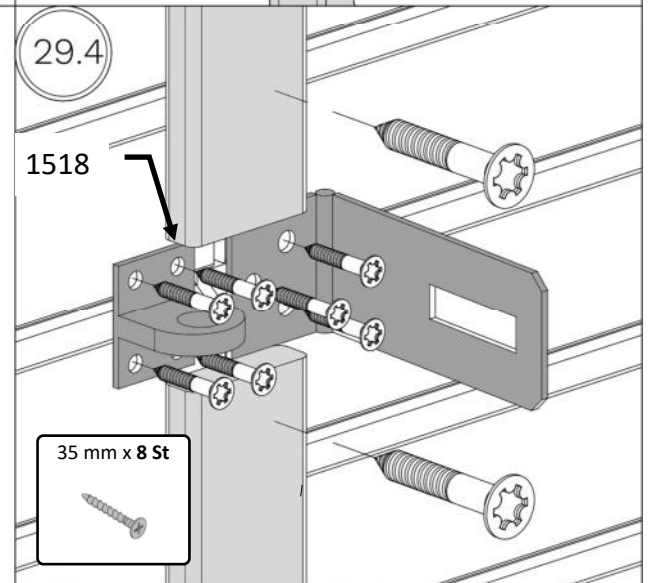
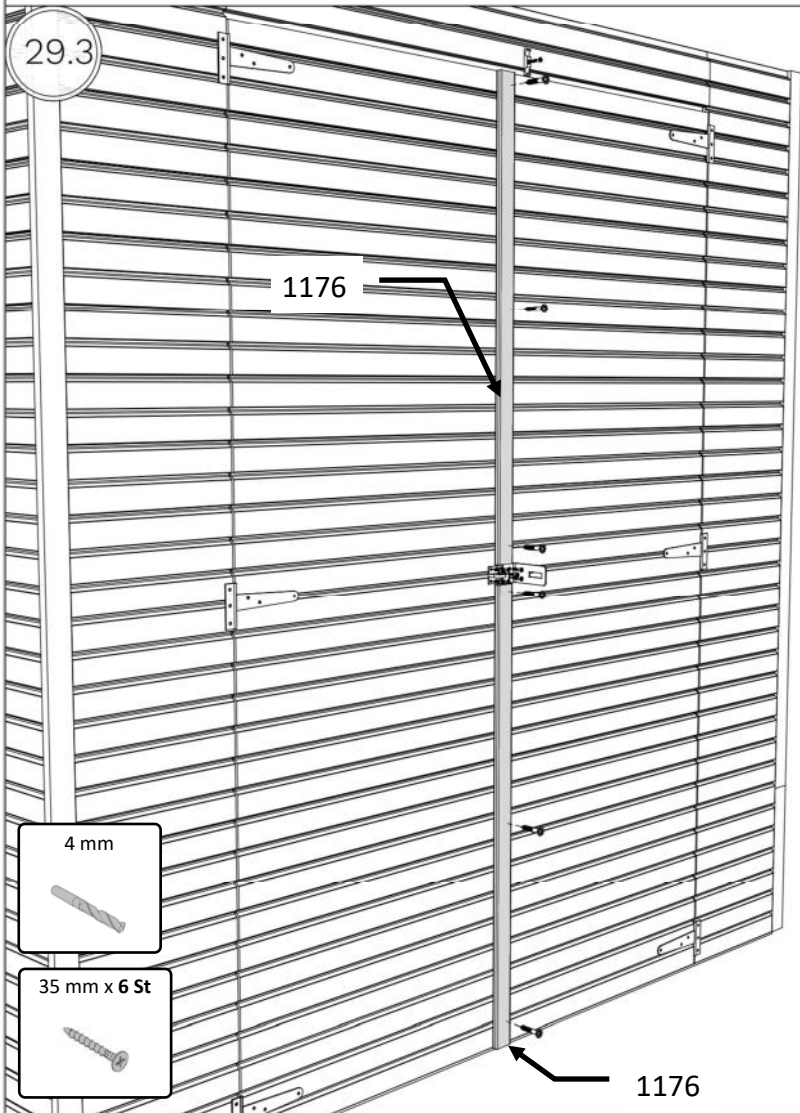
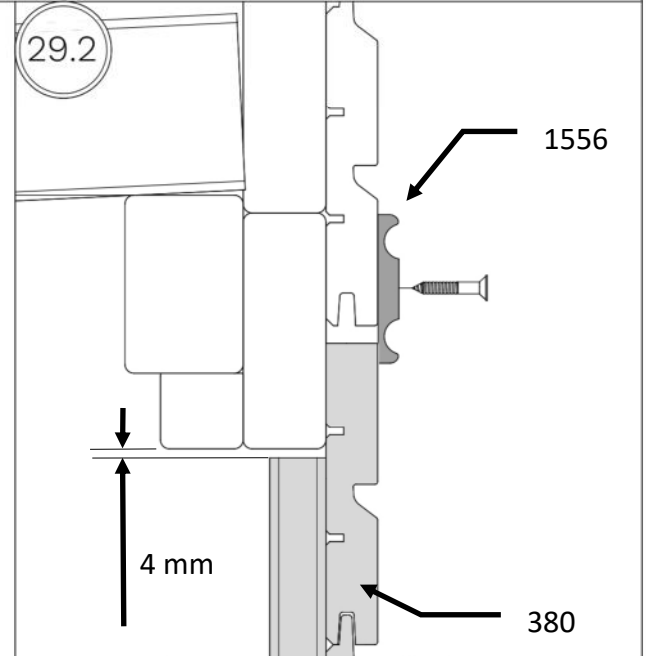
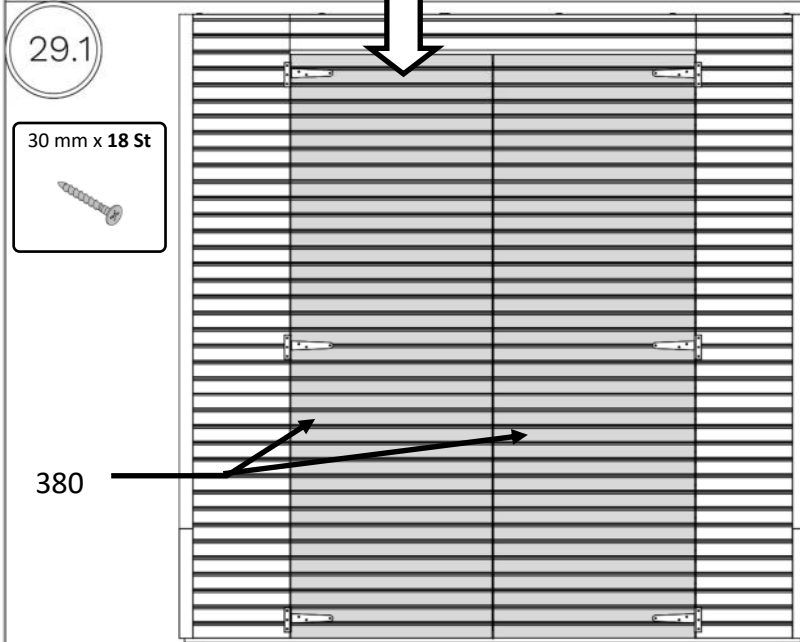
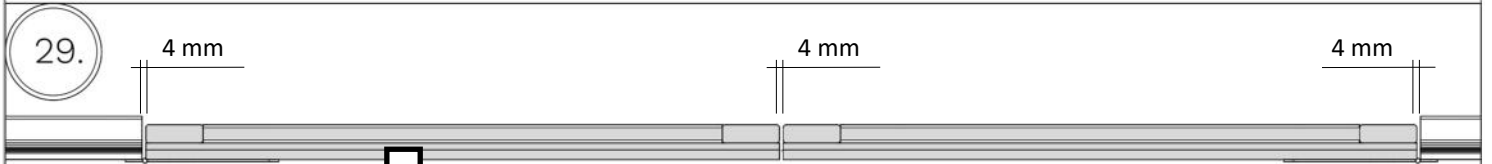

WC201250

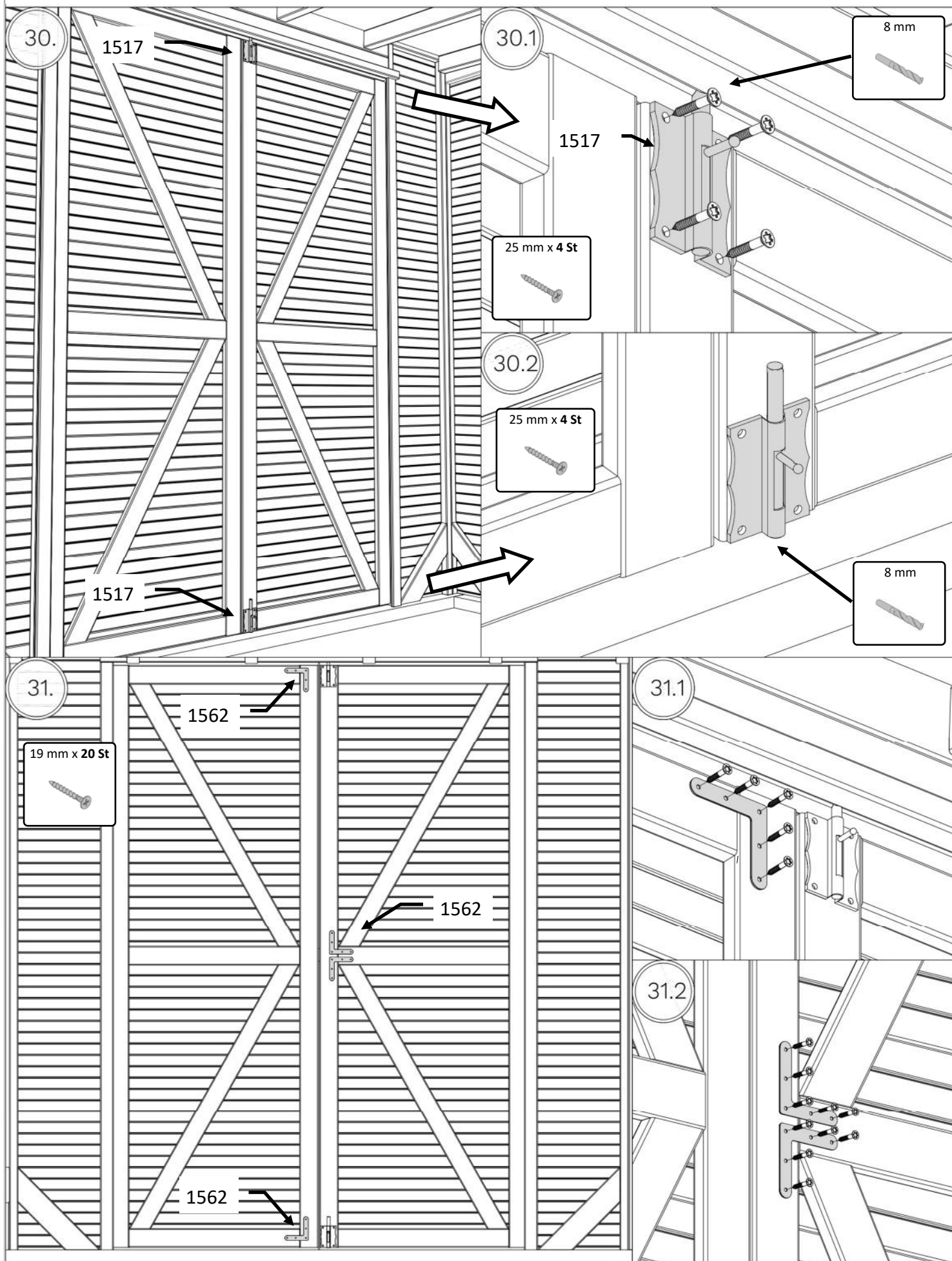

WC201250

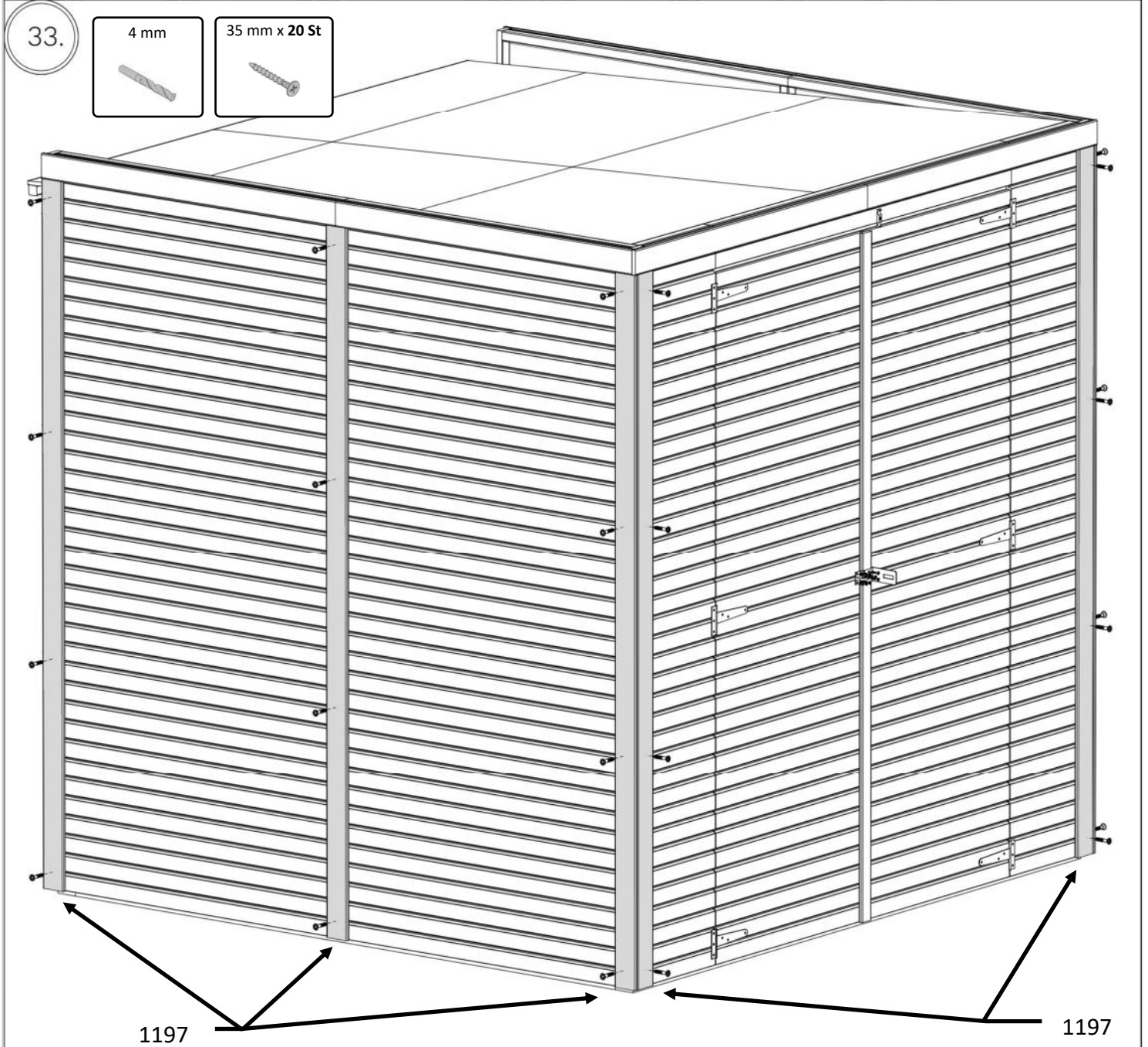
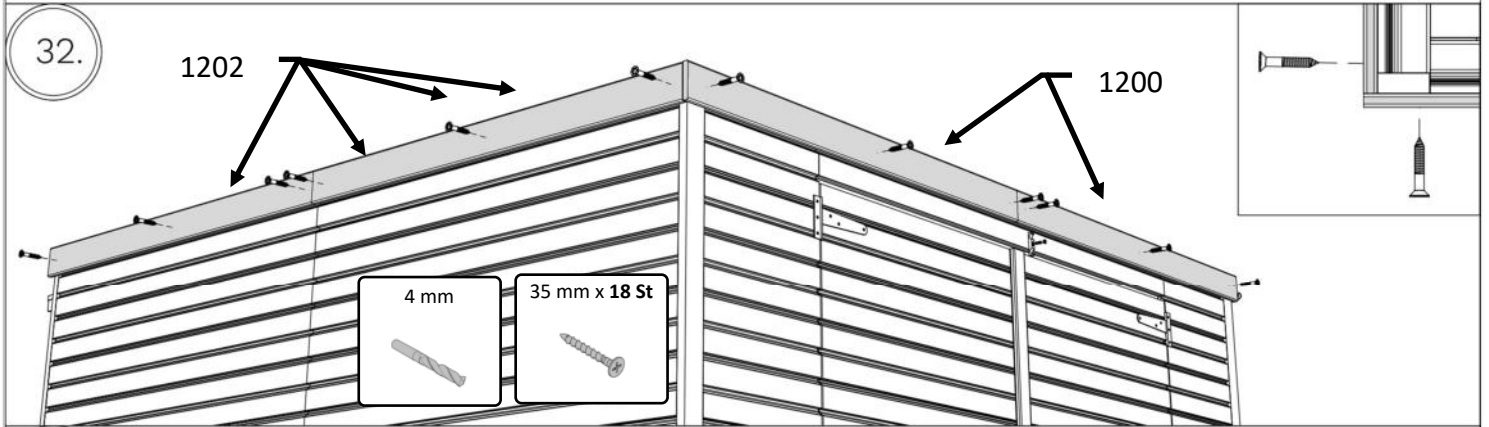

WC201250

34.

4 mm



35 mm x 24 St

