

WC201161

Aufbauanleitung

DE - Bevor Sie beginnen:

- Es ist empfehlenswert sich etwas Zeit zu nehmen, um die Aufbauanleitung zu lesen, bevor mit dem Aufbau begonnen wird.
- Der Aufbau sollte in der vorgegebenen Reihenfolge erfolgen.
- Die Aufbauanleitung dient lediglich als Richtschnur für den Aufbau. Nicht alle Schritte sind im Detail vorgegeben.
- Bitte prüfen Sie alle Teile auf Vollständigkeit und Zustand vor dem Aufbau. Der Aufbau sollte durch mindestens 2 Personen erfolgen.
- Bei starkem Wind sollte der Aufbau nicht erfolgen.
- Bohren Sie die Teile vor, wo es angezeigt wird.
- Wir empfehlen, das Gerätehaus erst nach weitgehendem Aufbau vor Anbringung der Deckleisten mit Farbe oder Holzlasur zu behandeln, da sich die Elemente bei einer einseitigen Behandlung verziehen können, wodurch der Aufbau erschwert werden könnte.

Instructions d'assemblage

FR - Avant de commencer:

- Avant de commencer le processus d'assemblage, veuillez s'il vous plaît vous familiariser parfaitement avec les instructions.
- La maison doit être assemblée suivant la séquence indiquée dans les instructions.
- Les instructions s'entendent comme lignes directrices, toutes les étapes ne sont pas décrites en détails.
- Avant de commencer l'assemblage, vérifier tous les éléments.
- Deux personnes sont nécessaires au minimum pour l'assemblage.
- Ne pas tenter d'assembler la maison dans des conditions de vents forts.
- Percer les trous dans les éléments suivant les marques.

Montage-instructie

NL - Alvorens te beginnen:

- Voordat u begint met de montage raden wij u aan de handleiding grondig door te lezen.
- Bij de montage van het huis dient u de volgorde zoals deze in de handleiding is aangegeven te volgen.
- De handleiding is bedoeld als richtsnoer, niet alle stappen zijn in detail uitgewerkt.
- Vóór de montage dienen alle details gecontroleerd te worden.
- De montage van het huis dient door tenminste twee personen uitgevoerd te worden.
- Het huis nooit in harde wind opbouwen.
- Gat en onderdelen boren, waar dit staat aangegeven.

Pokyny k montáži

CZ - Než začnete:

- Než začnete s montáží, seznámte se důkladně s těmito pokyny.
- Domek musí být sestaven v pořadí uvedeném v pokynech.
- Pokyny slouží pouze jako vodítko, ne všechny kroky jsou zde popsány podrobně.
- Než začnete s montáží, zkontrolujte všechny díly.
- K montáži jsou zapotřebí minimálně dvě osoby.
- Nepokoušejte se smontovat domek za silného větru.
- Vyvrtejte do dílů otvory podle značek.

Pokyny pre montáž

SK - Predtým, než začnete:

- Predtým, než začnete montovať, sa, prosím, dôkladne oboznámte s týmito pokynmi.
- Dom je potrebné zmontovať podľa poradia uvedeného v pokynoch.
- Tieto pokyny poskytujú návod, nepopisujú však detailne všetky kroky.
- Predtým, než začnete montovať, skontrolujte všetky časti.
- Pri montáži sú potrební najmenej dvaja ľudia.
- Nepokúšajte sa montovať dom pri silnom vetre.
- Otvory v jednotlivých častiach vyvrťajte podľa označenia.

DE - Technische Änderungen vorbehalten.







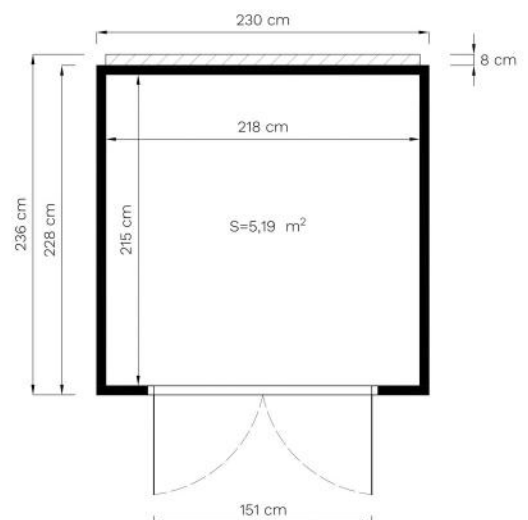
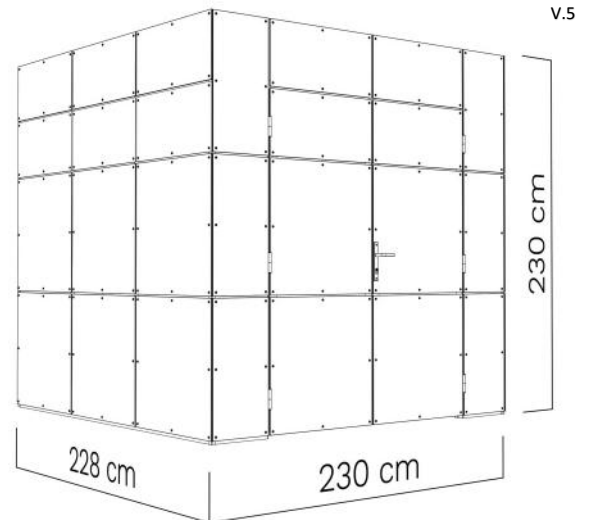



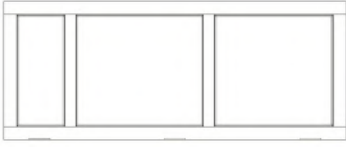
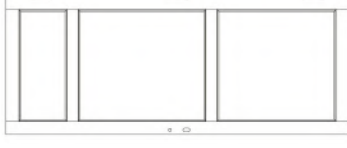
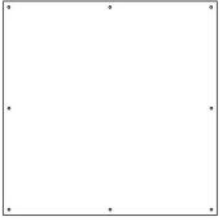
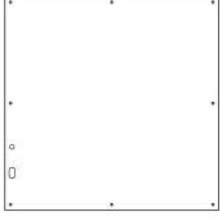

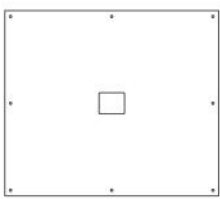









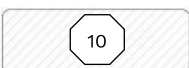

Alle Maße sind ca. Maße.

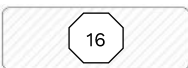
EN - Technical modifications reserved.





















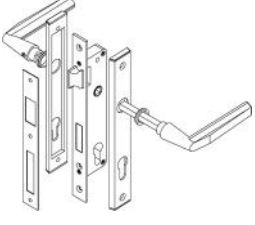
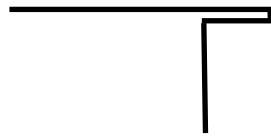

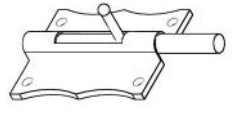

All dimensions are approximate dimensions.



WC201161

ID	Details in mm (Tolerance/Toleranz ...+ 2mm)	Pcs.	ID	Details in mm (Tolerance/Toleranz ...+ 2mm)	Pcs.
60	32 x 760 x 1893 	x 1	61	32 x 760 x 1893 	x 1
1059	6 x 754 x 754 TRESPA 	x 24	1060	6 x 754 x 754 TRESPA 	x 1
1061	6 x 654 x 754 TRESPA 	x 2	1062	6 x 654 x 754 TRESPA 	x 1
1063	6 x 372 x 754 TRESPA 	x 13	1064	6 x 372 x 754 MAKROLON UV GLASS 	x 3
1029	28 x 80 x 2300 	x 12	1030	28 x 80 x 2268 	x 9
1031	28 x 80 x 2205 	x 4	1032	28 x 80 x 2184 	x 8
1033	28 x 80 x 2161 	x 8	1034	28 x 80 x 1752 	x 1
1037	28 x 80 x 684 	x 19	1038	28 x 80 x 676 	x 4
1039	28 x 80 x 657 	x 16	1040	28 x 80 x 636 	x 4
1041	28 x 80 x 632 	x 4	1043	28 x 80 x 590 	x 2
1044	28 x 80 x 541 	x 4	1045	28 x 80 x 387 	x 3
1046	28 x 80 x 332 	x 4	1047	28 x 80 x 302 	x 4
1048	28 x 80 x 296 	x 6	1049	28 x 80 x 254 	x 4
1050	28 x 80 x 224 	x 7	1052	28 x 80 x 136 	x 2
1054	28 x 28 x 1092 	x 2			

WC201161

ID	Details in mm (Tolerance/Toleranz ...+ 2mm)	Pcs.	ID	Details in mm (Tolerance/Toleranz ...+ 2mm)	Pcs.
1053	40 x 60 x 1913 	x 2	1502	Ø4,5 x 75 	x 8
1058	12 x 42 x 1894 	x 1	1057	12 x 524 x 1150 MFP 	x 2
516	12 x 830 x 1150 MFP 	x 4	1561	MR2628 	x 1
1500	Ø5 x 120 	x 44	1505	Ø4,5 x 50 	x435
1506	Ø4 x 35 	x 95	1560	Ø4,8 x 32 Grey/white Ø4,8 x 32 Anthrazite 	x320 x320
1531		x 1	1570	65 x 38 x 2184 	x 1
1554		x 1	1527		x 3
1555		x 3	1517		x 2
1082	19 x 45 x 2000 	x 1	1559	EPDM 78 rm/lfm 	
1101	10 x 10 x 754 	x 2	1100	19 x 45 x 560 	x 3
1566	1 x 9 	x 4	1565	Ø4 x 16 	x 4
1563	12 x 65 x 1175 	x 6	1567	3 x 7 	x 4
			1564	Ø4,8 x 38 	x 18

WC201161

Before assembly the shed, sort frame pieces by length!
 Vor dem Zusammenbauen sind die Holzteile der Länge nach zu sortieren!



1029	28 x 80 x 2300		x 12	1030	28 x 80 x 2268		x 9
1031	28 x 80 x 2205		x 4	1032	28 x 80 x 2184		x 8
1033	28 x 80 x 2161		x 8	1034	28 x 80 x 1752		x 1
1037	28 x 80 x 684		x 19	1038	28 x 80 x 676		x 4
1039	28 x 80 x 657		x 16	1040	28 x 80 x 636		x 4
1041	28 x 80 x 632		x 4	1043	28 x 80 x 590		x 2
1044	28 x 80 x 541		x 4	1045	28 x 80 x 387		x 3
1046	28 x 80 x 332		x 4	1047	28 x 80 x 302		x 4
1048	28 x 80 x 296		x 6	1049	28 x 80 x 254		x 4
1050	28 x 80 x 224		x 7	1052	28 x 80 x 136		x 2

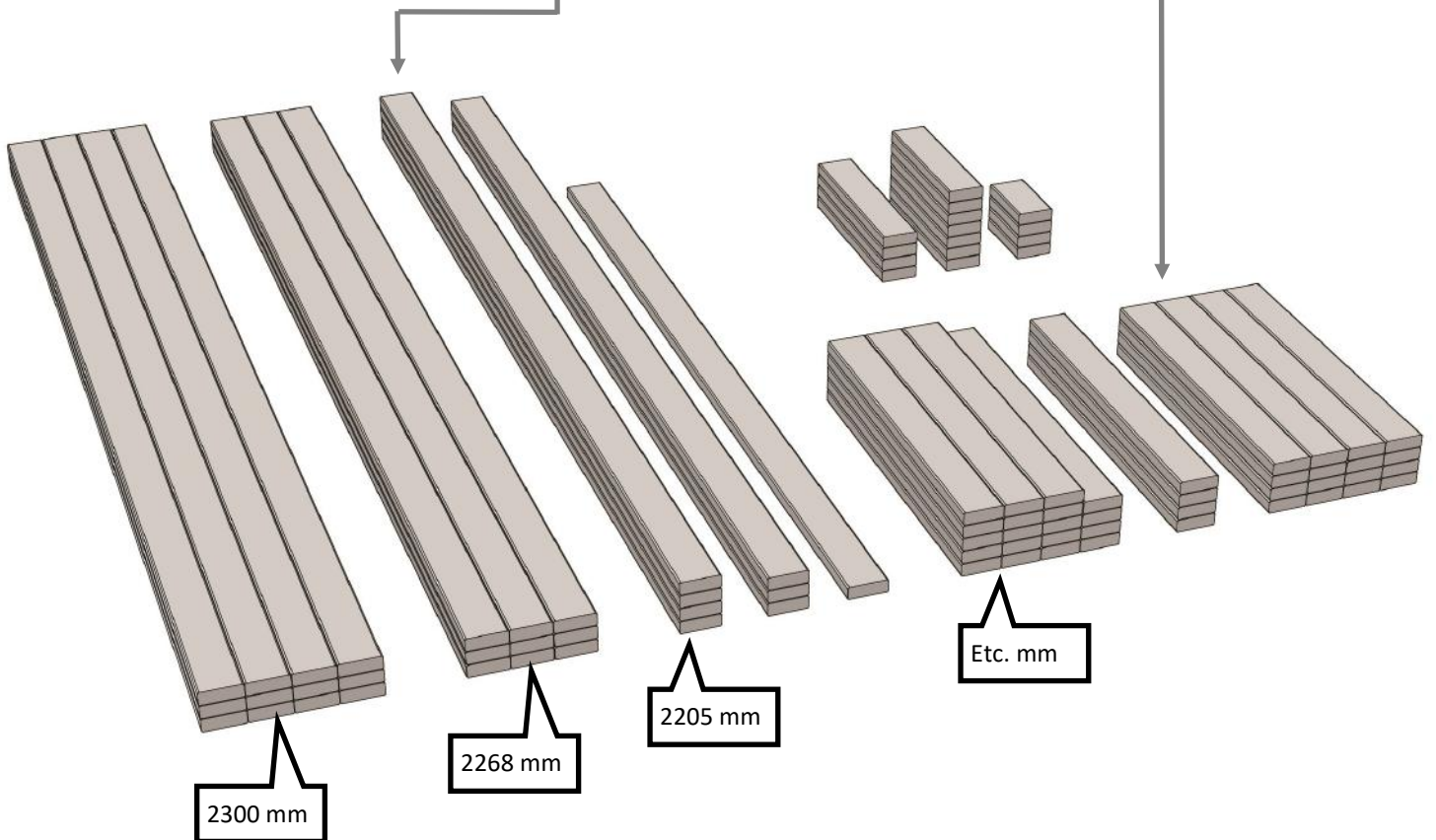

WC201161

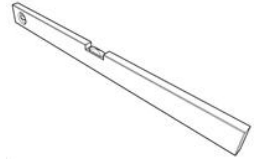
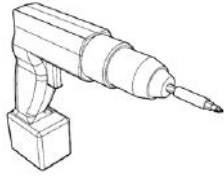
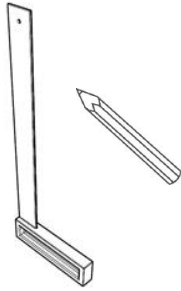

Ø 4 mm
Ø 8 mm

1.

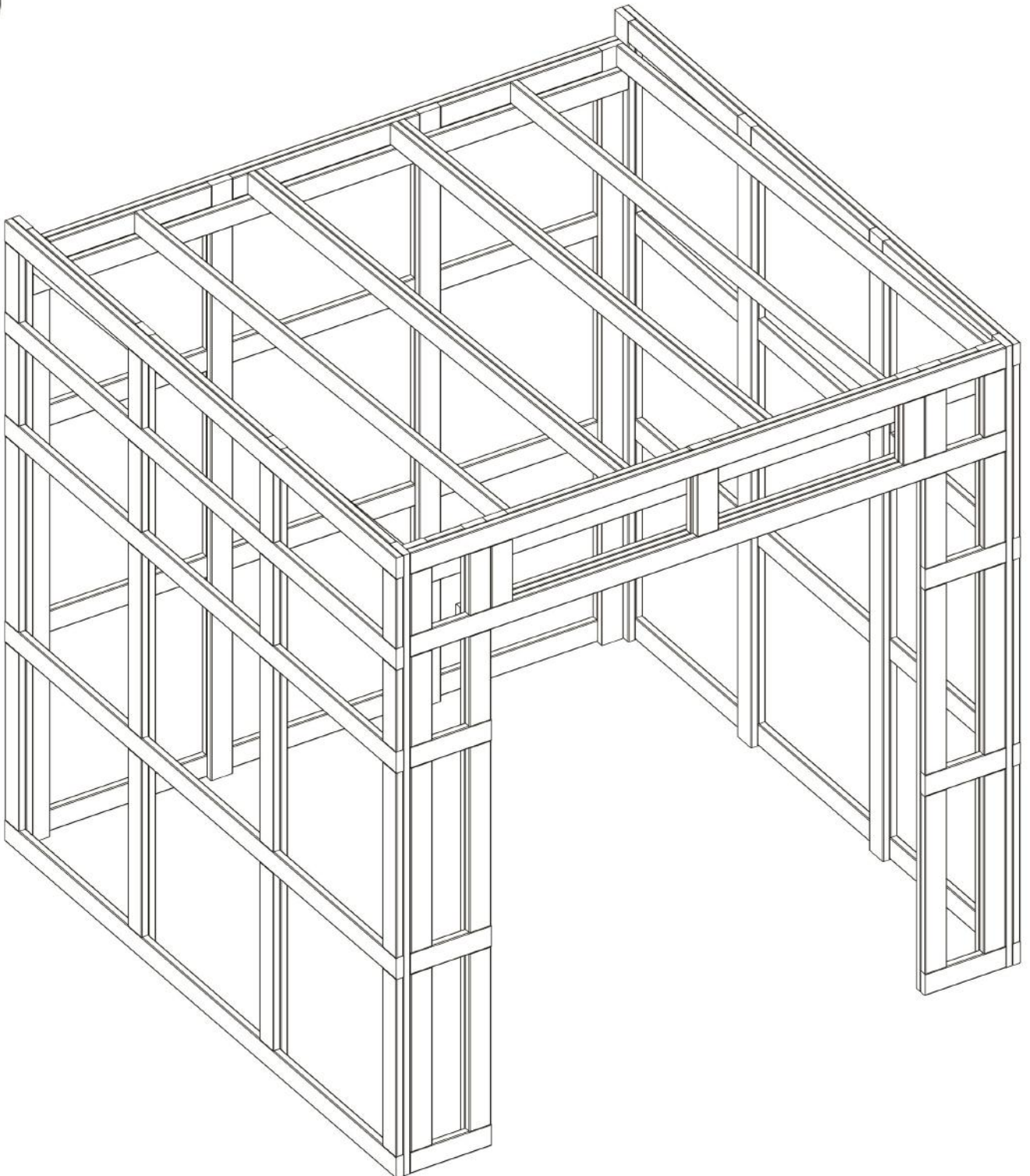

WC201161



6 Hours



WC201161

2.

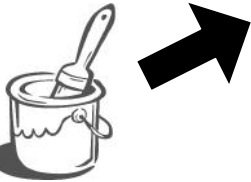
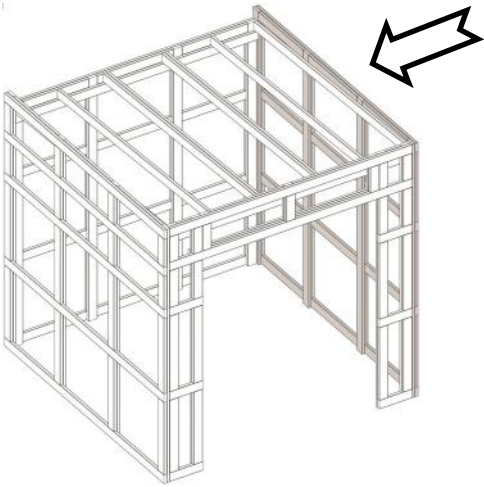

Holzschutzmittel / Wood preservative

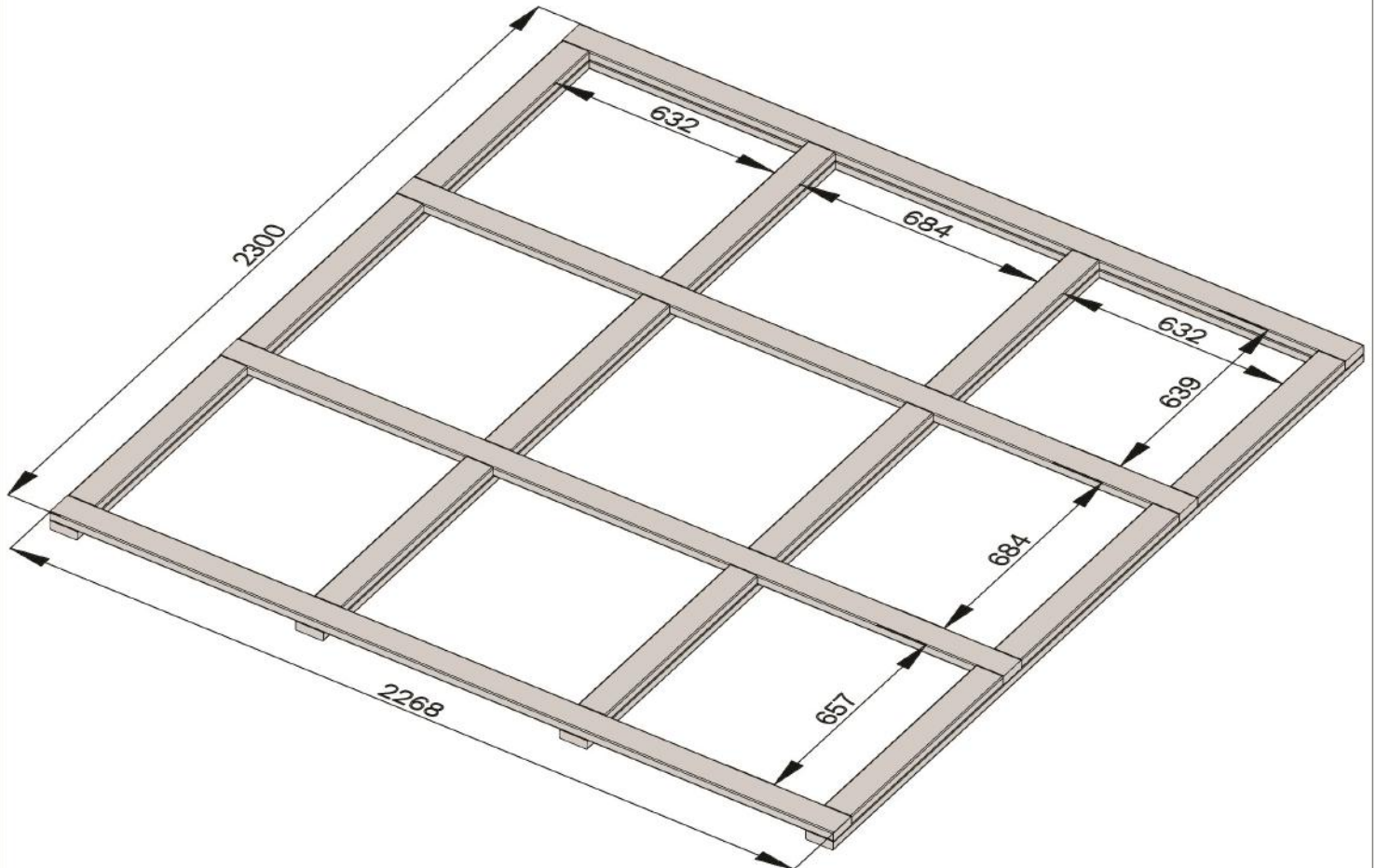
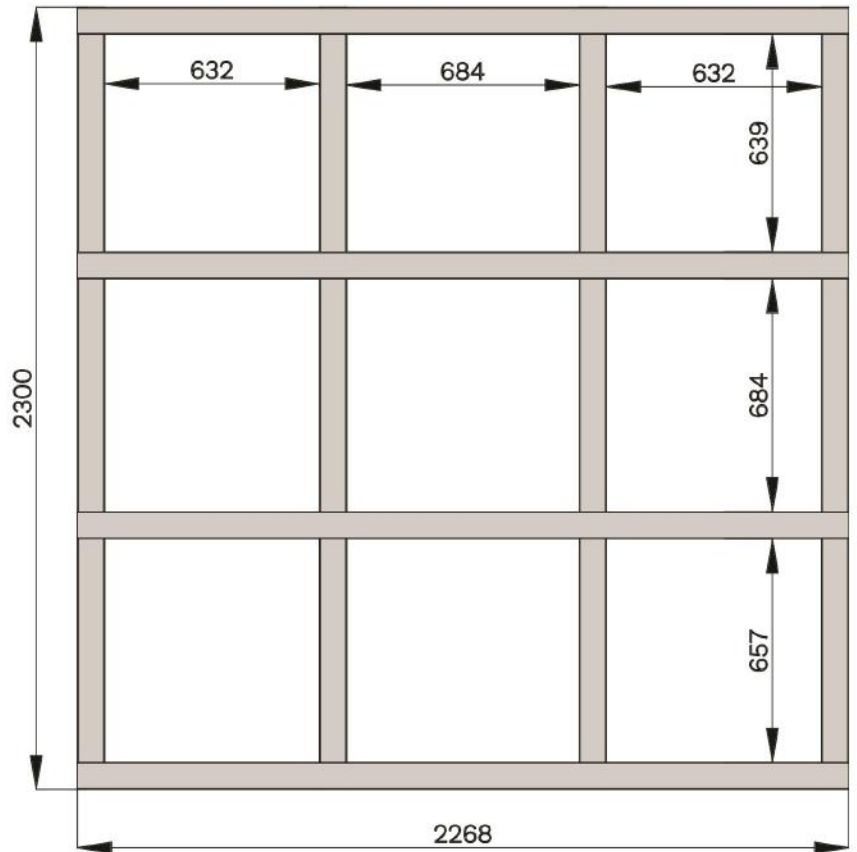

WC201161

3.

A=B

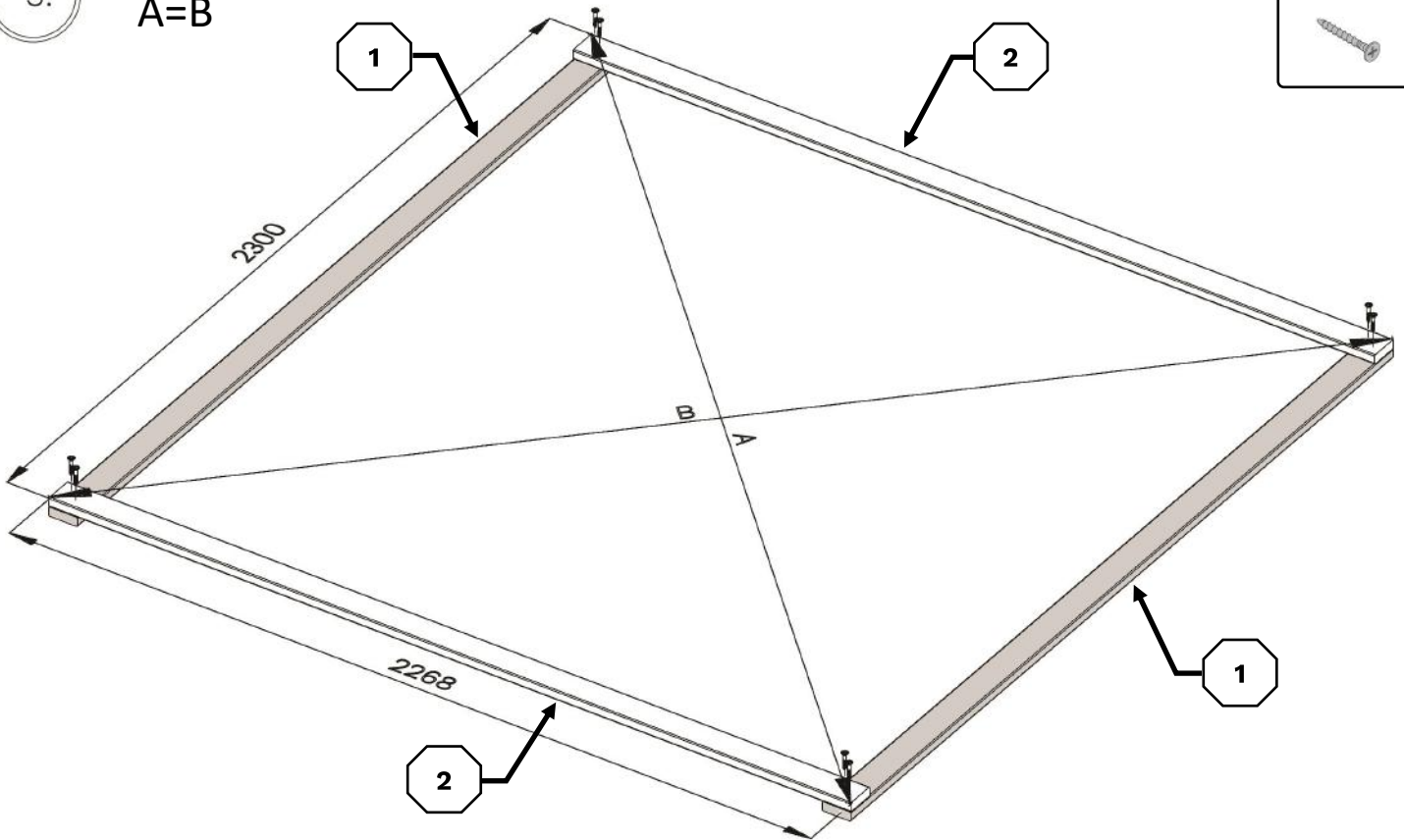

4.

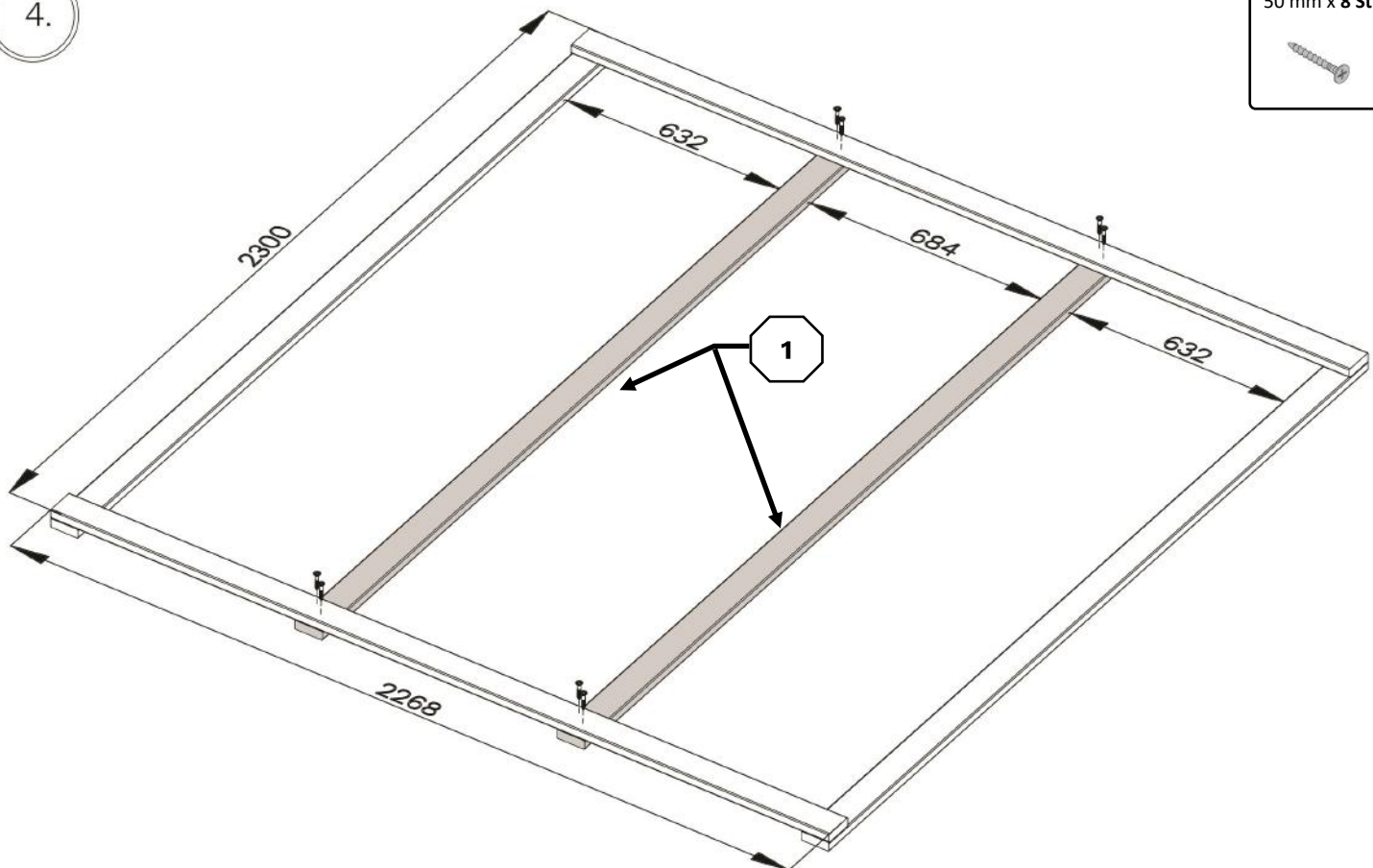

WC201161

5.

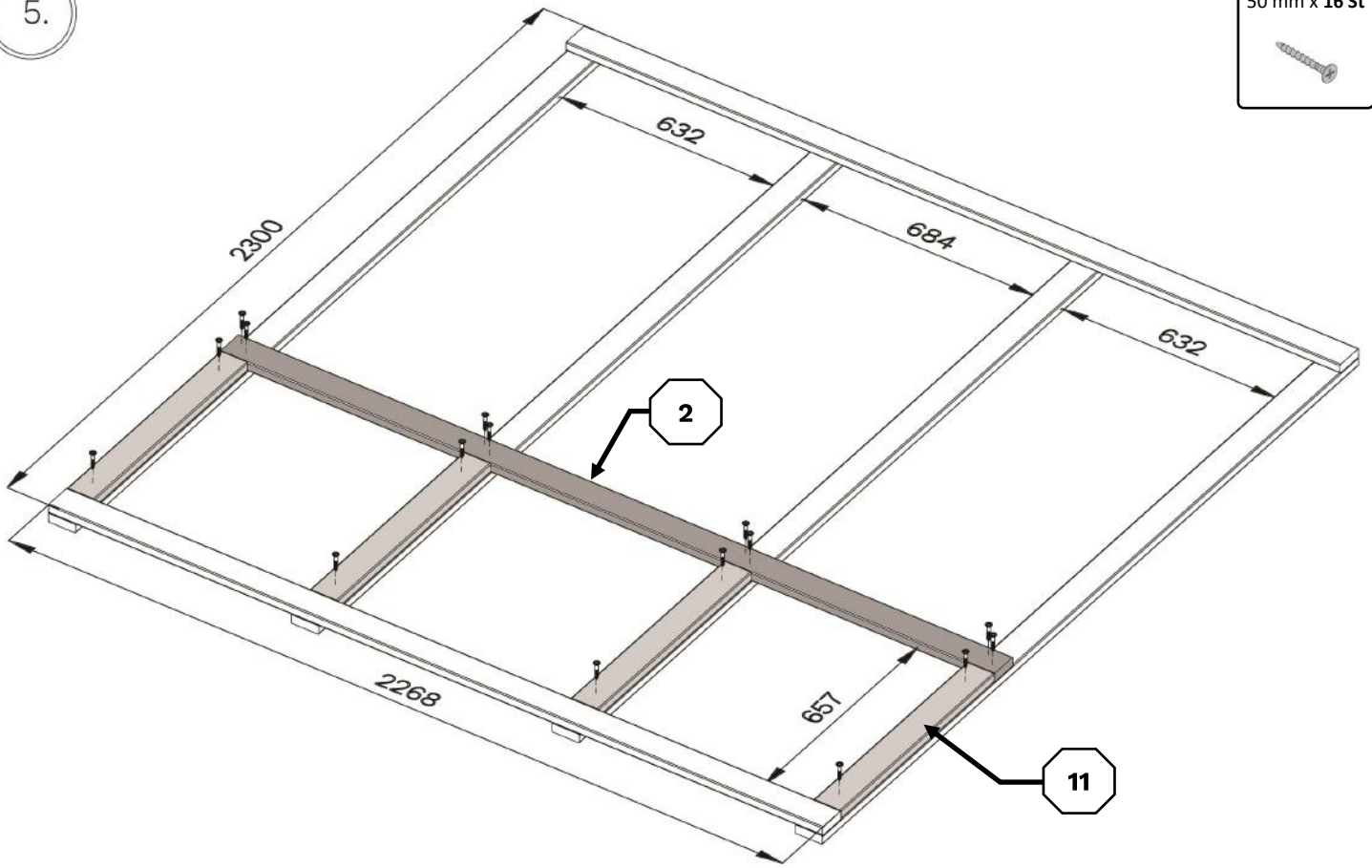

6.

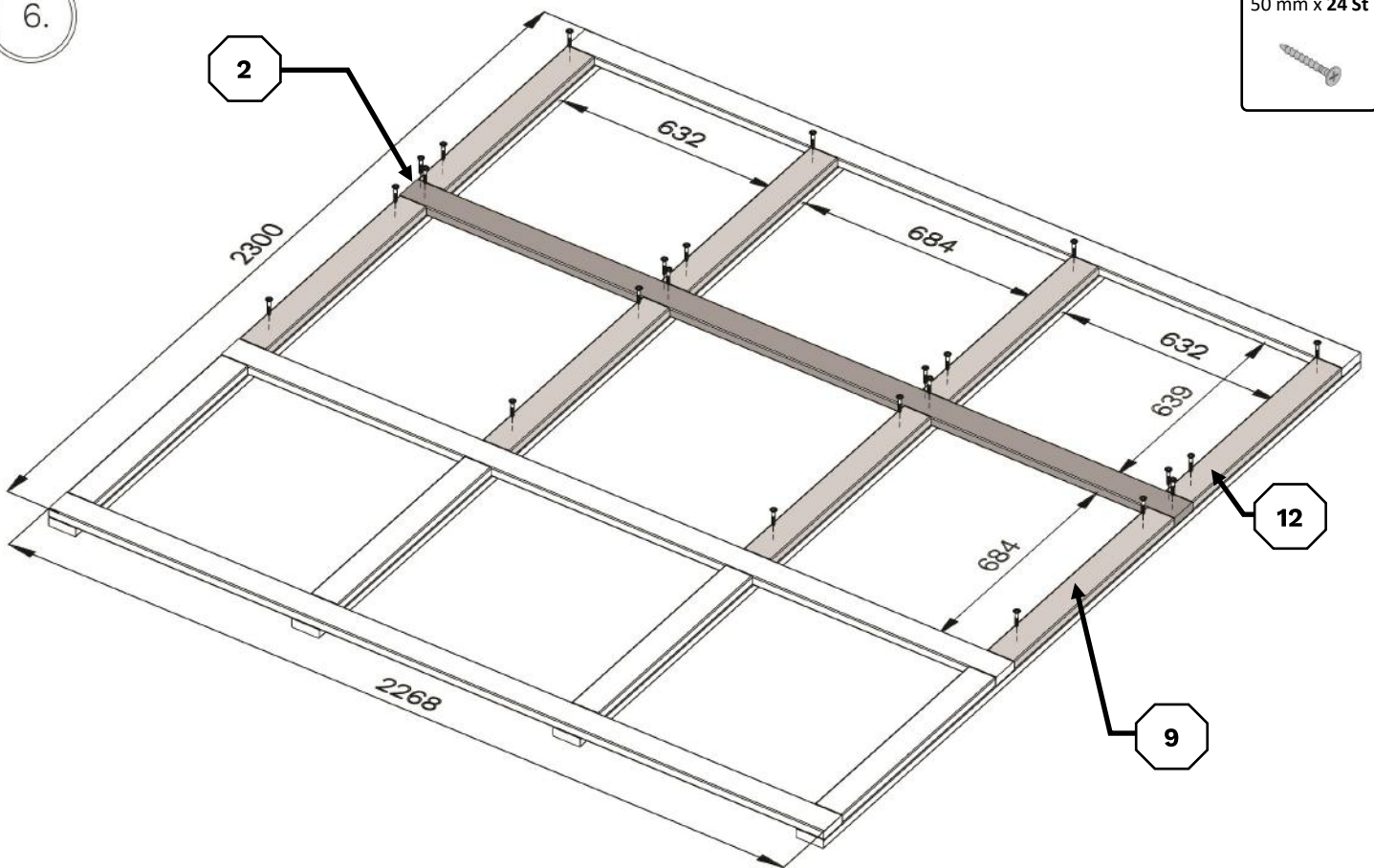

WC201161

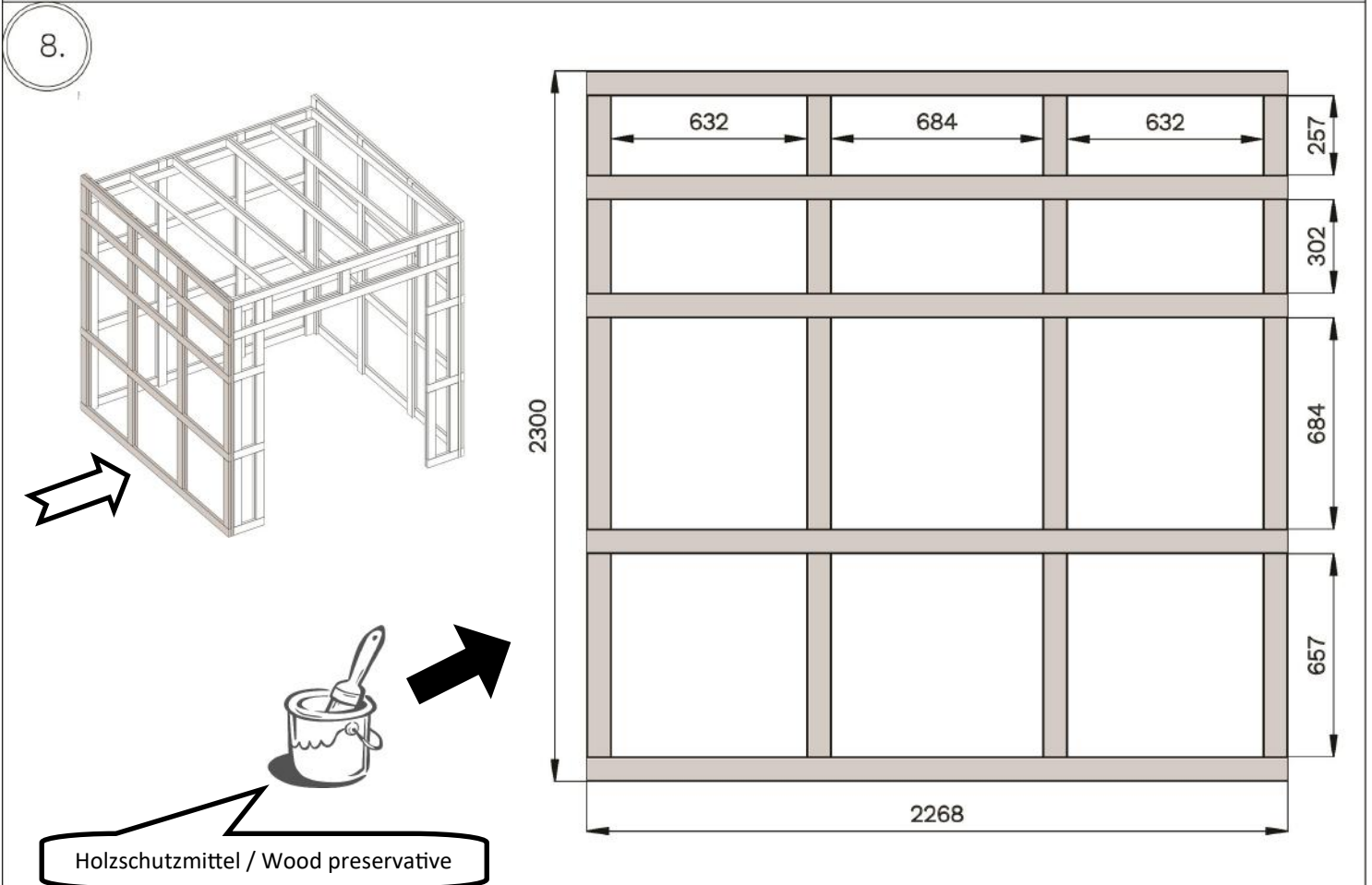
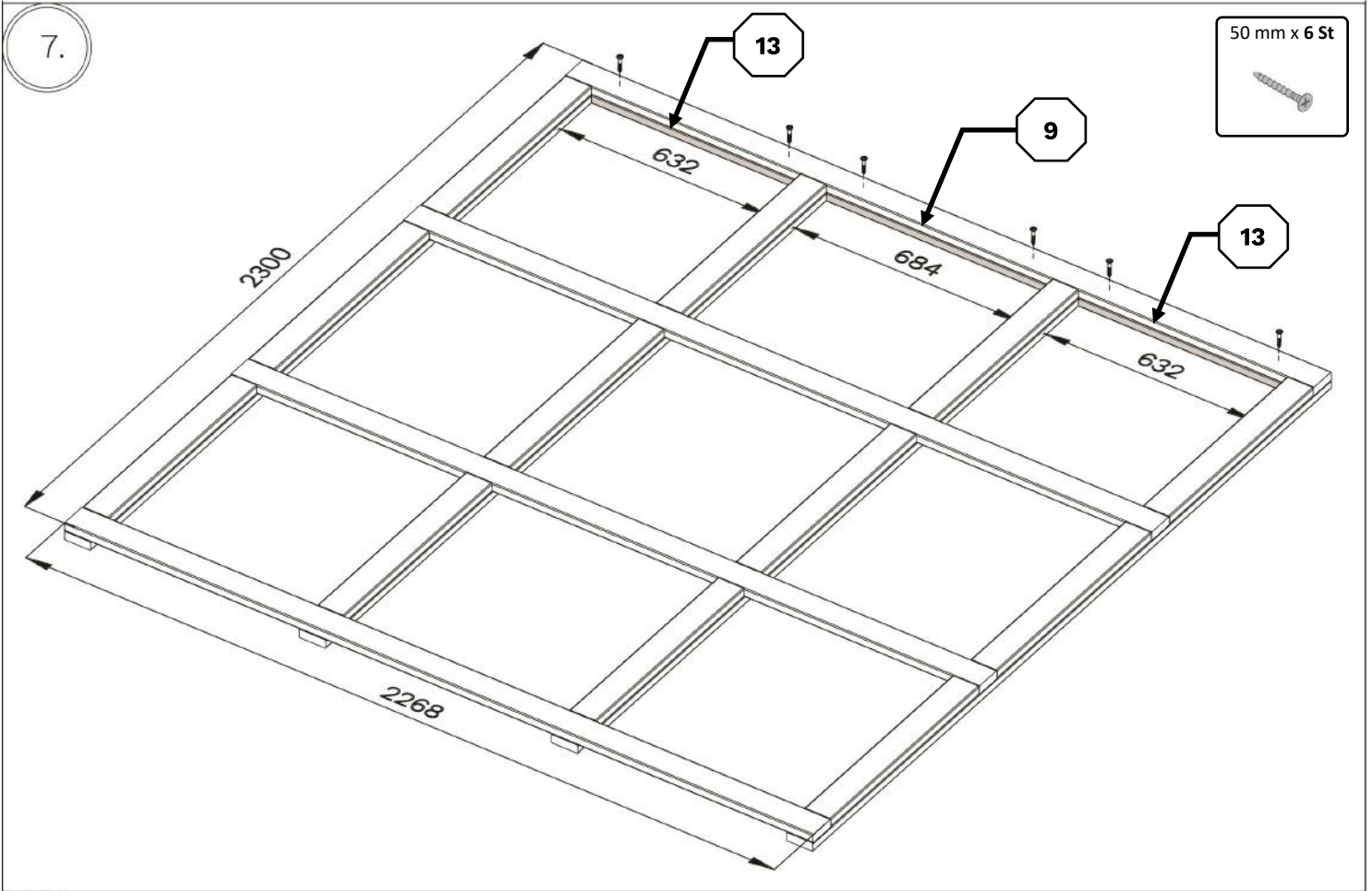

WC201161

9.

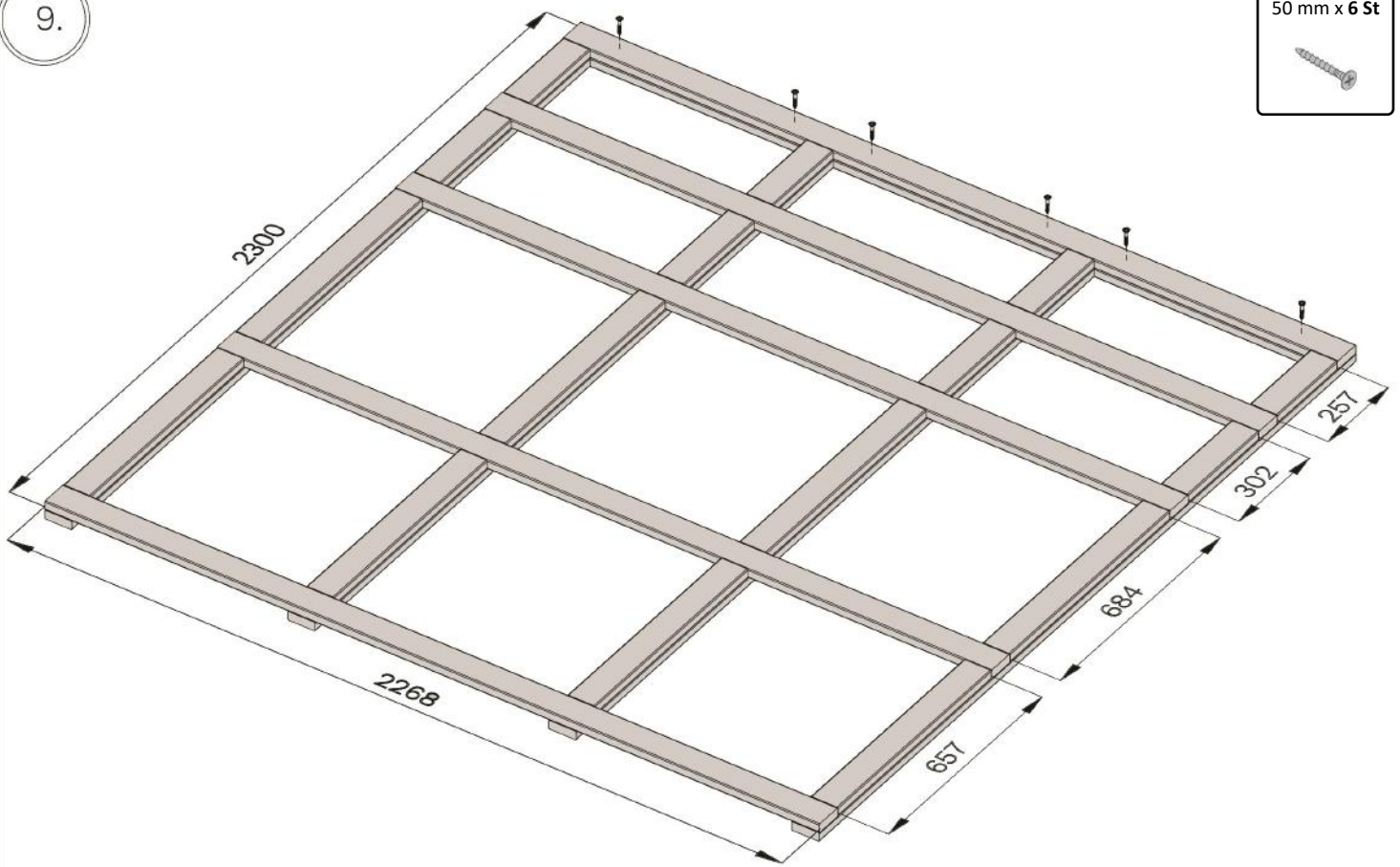

10.

A=B

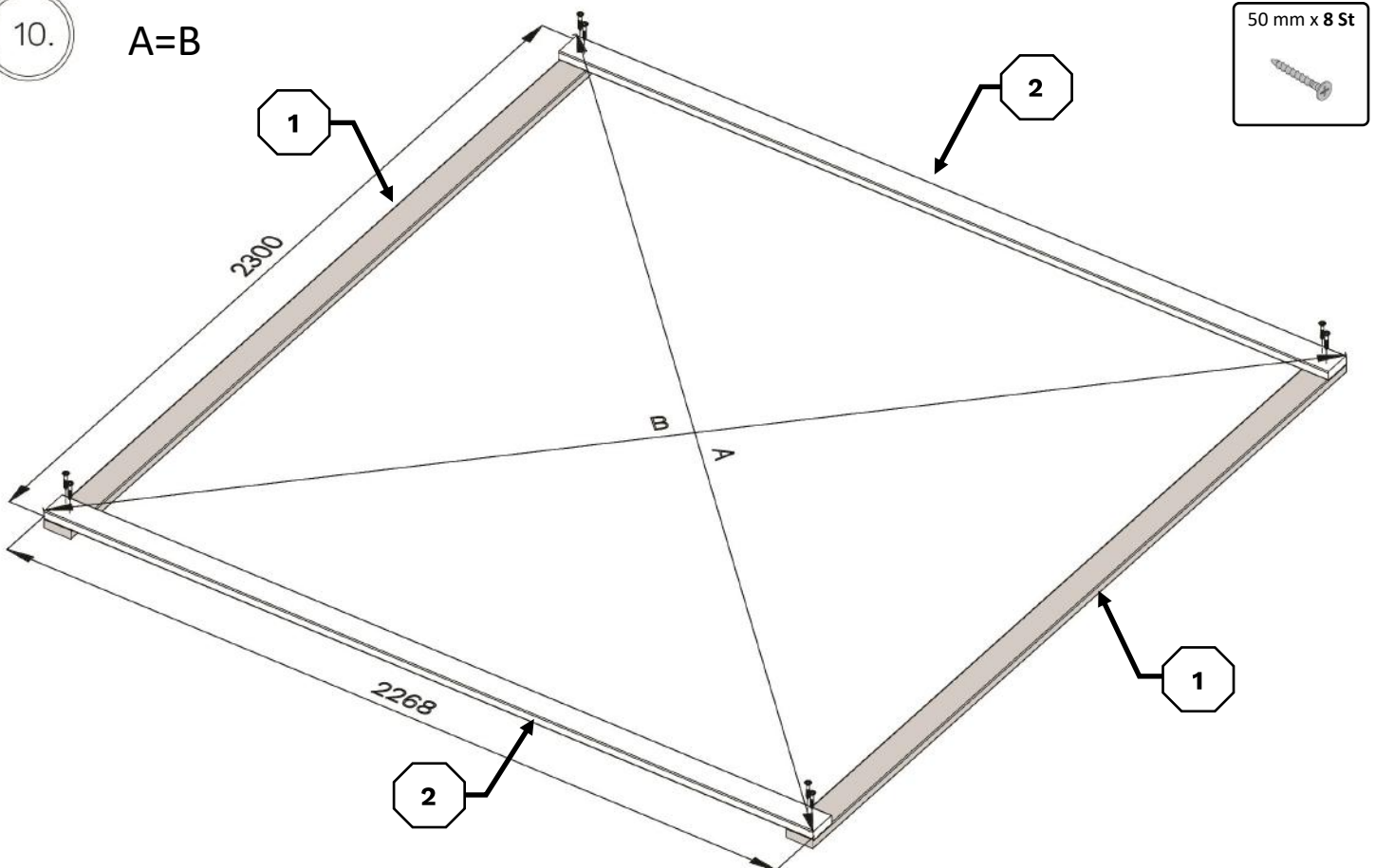

WC201161

11.

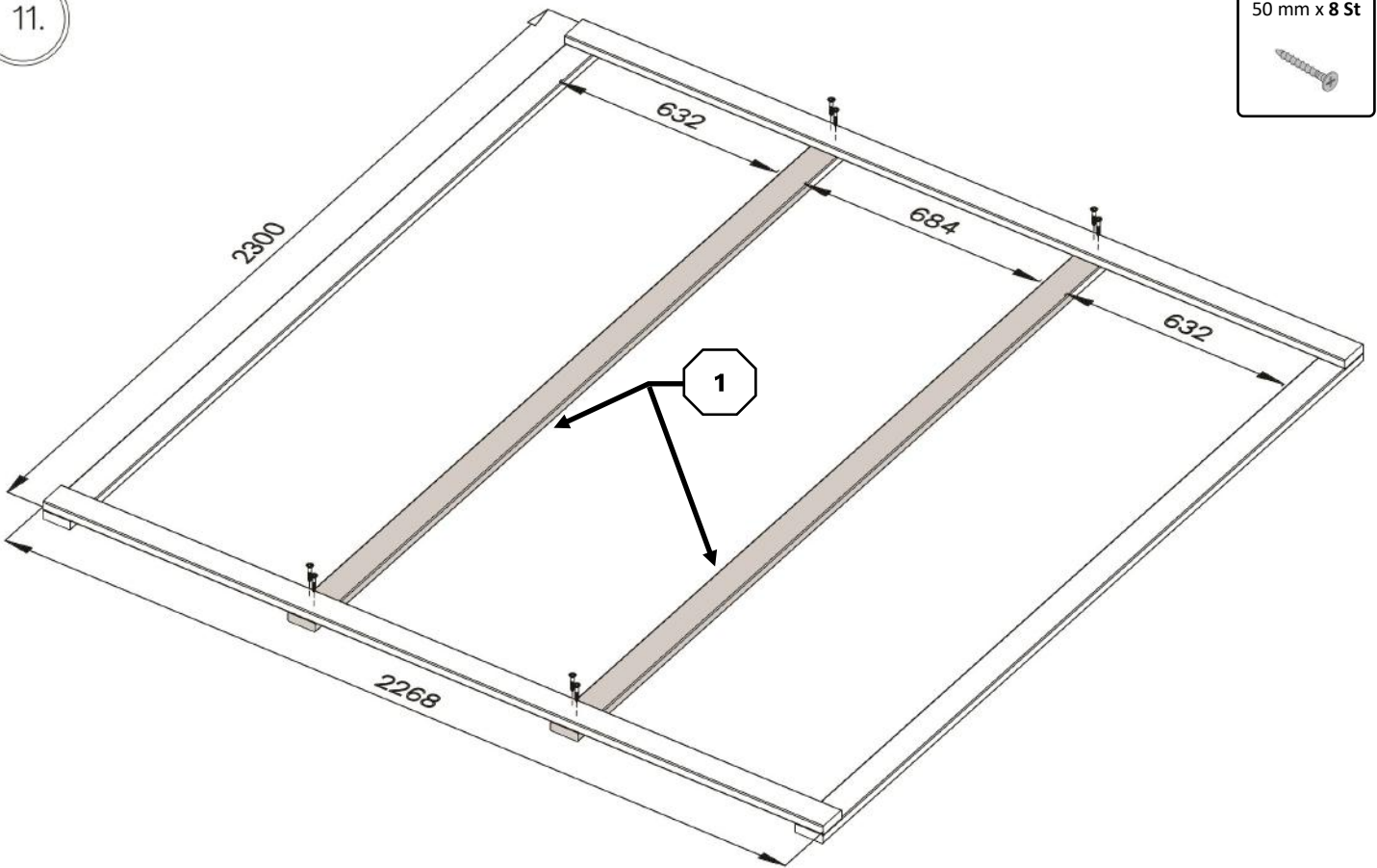

12.

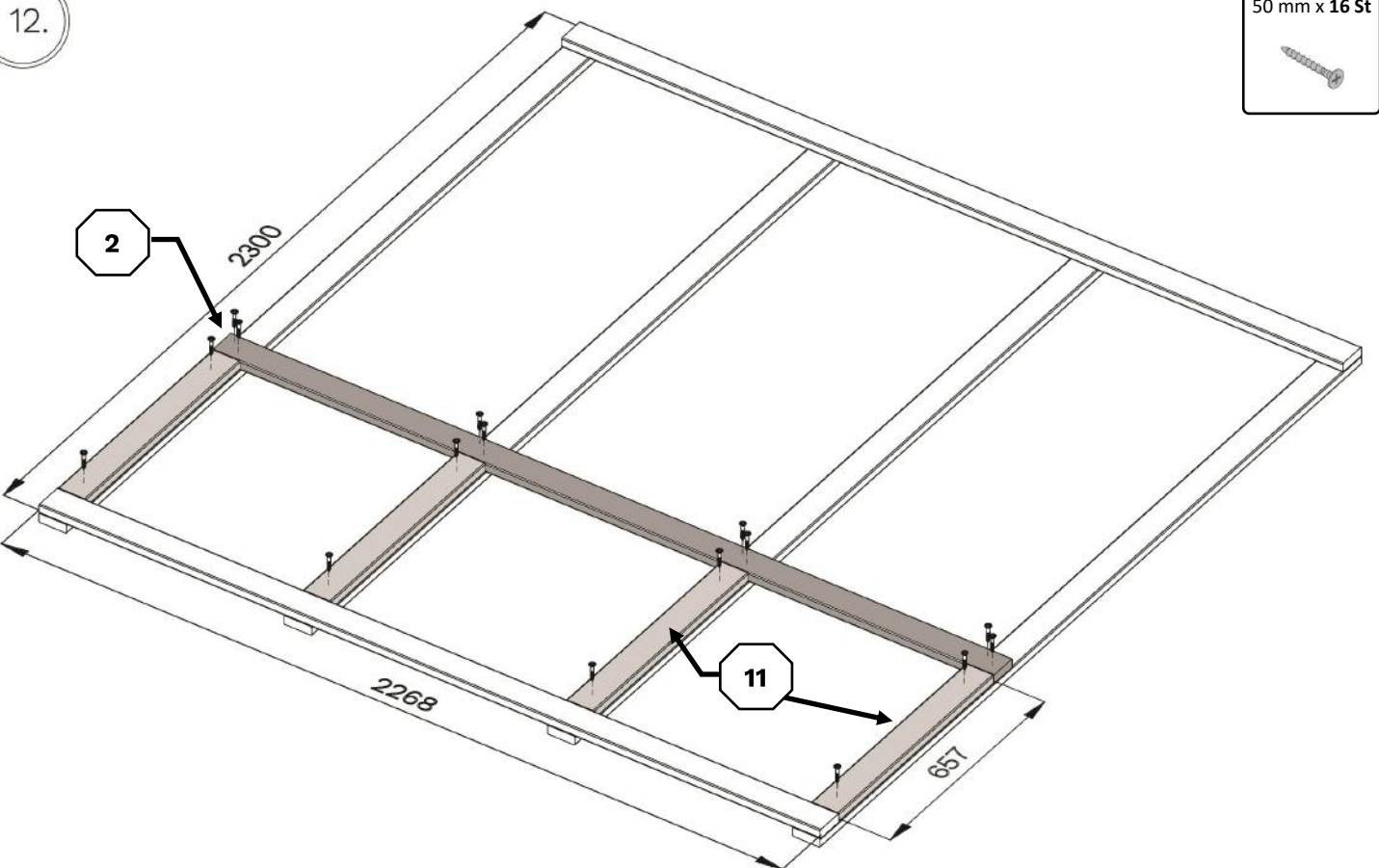

WC201161

13.

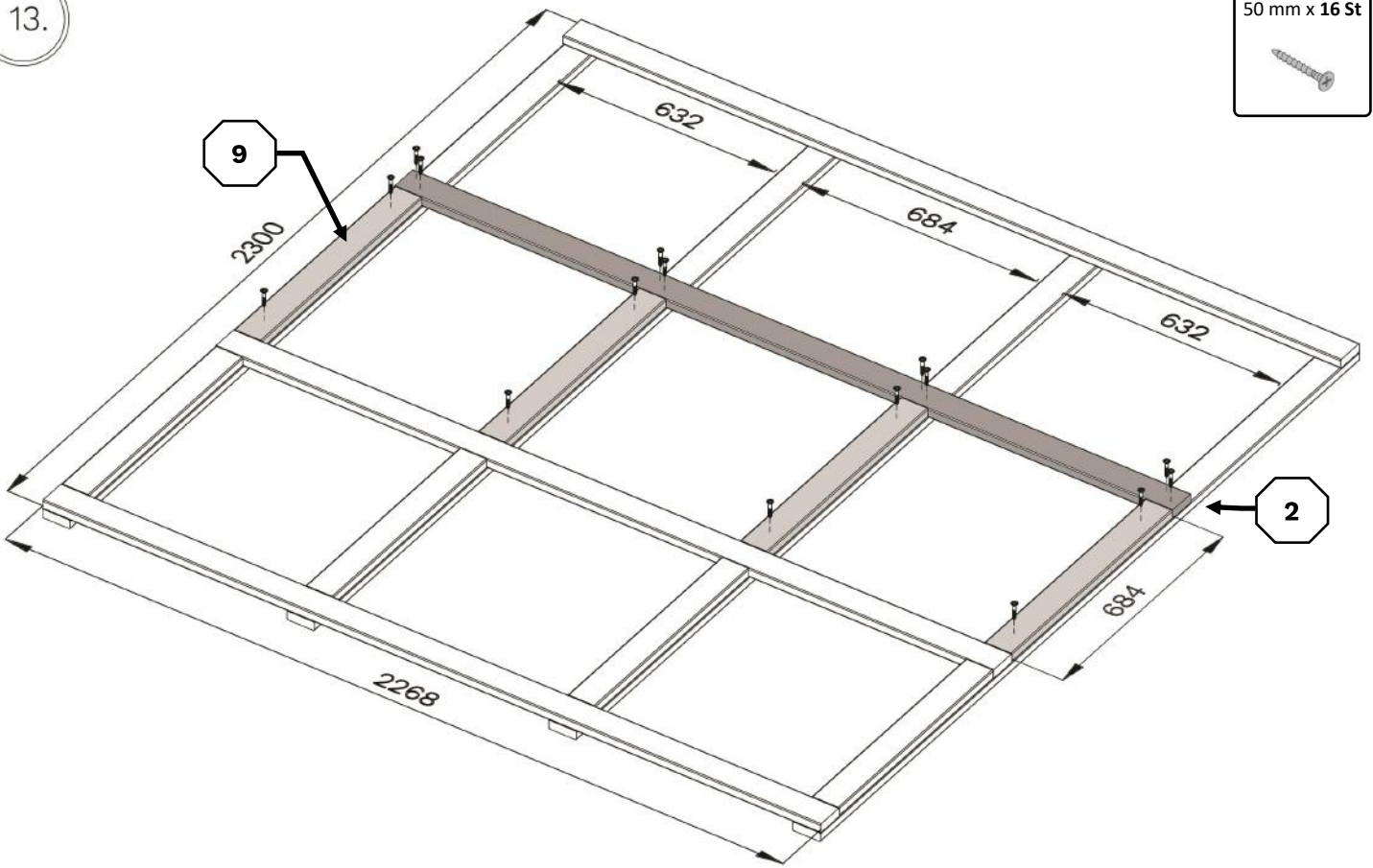

50 mm x 16 St



14.

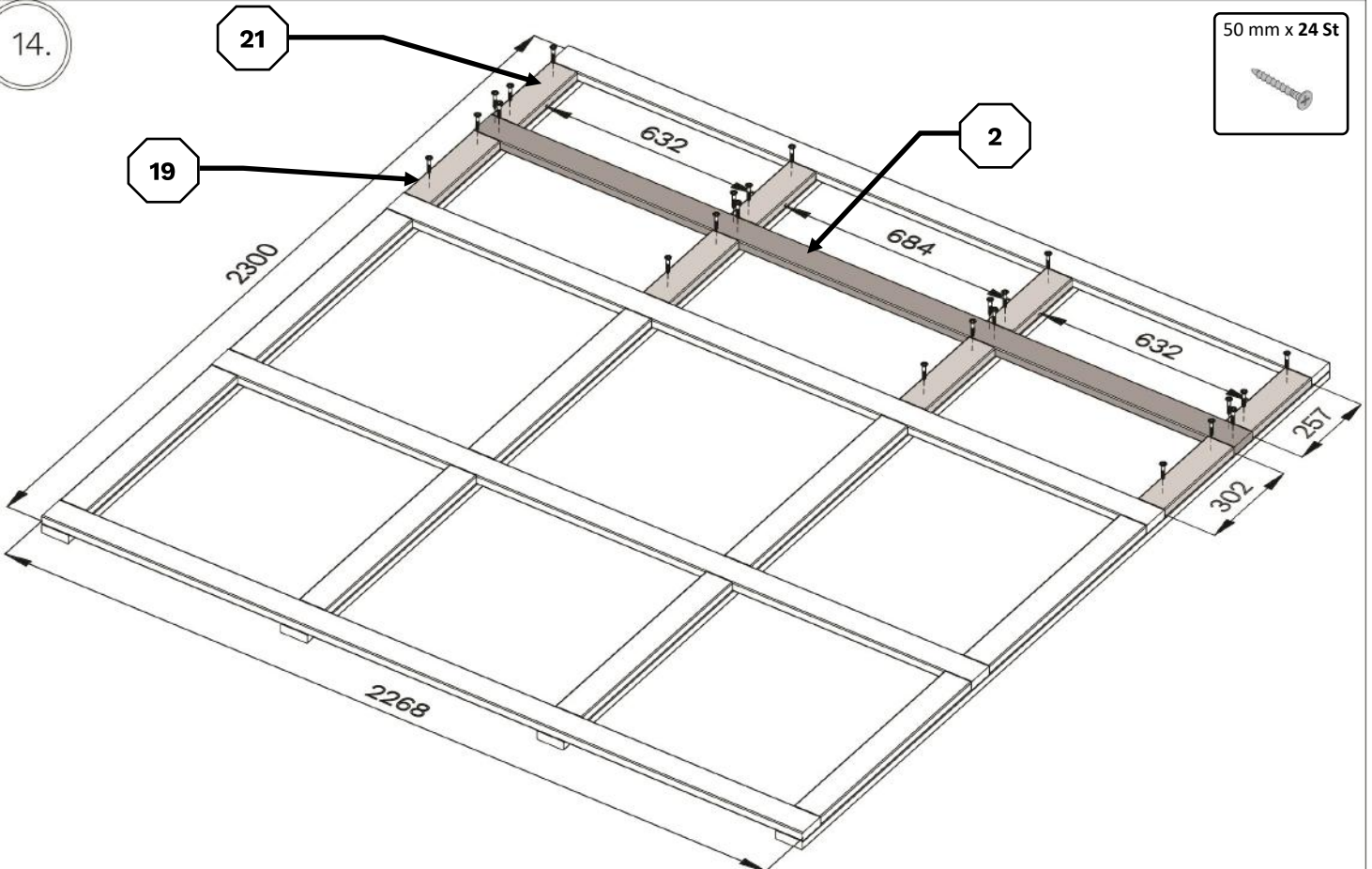

50 mm x 24 St



WC201161

15.

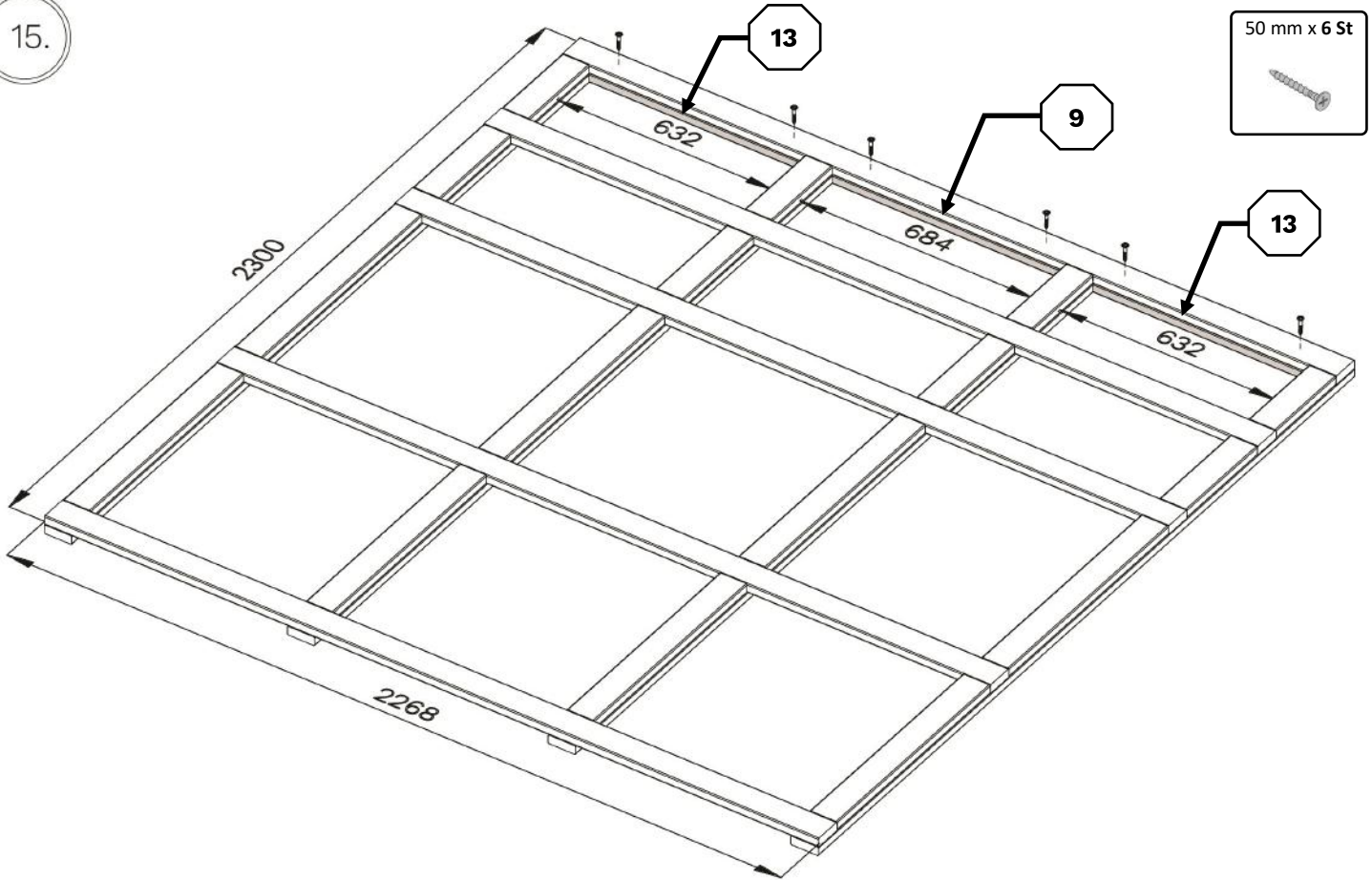

16.

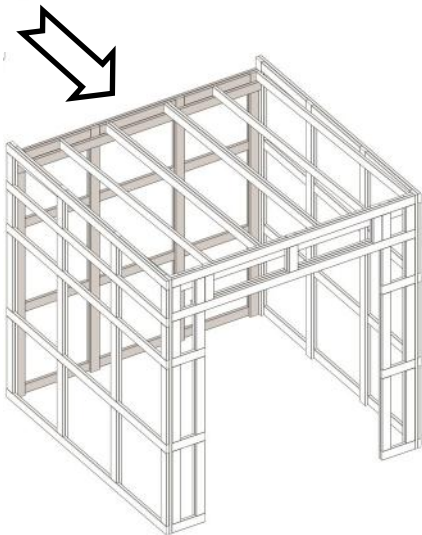

Holzschutzmittel / Wood preservative

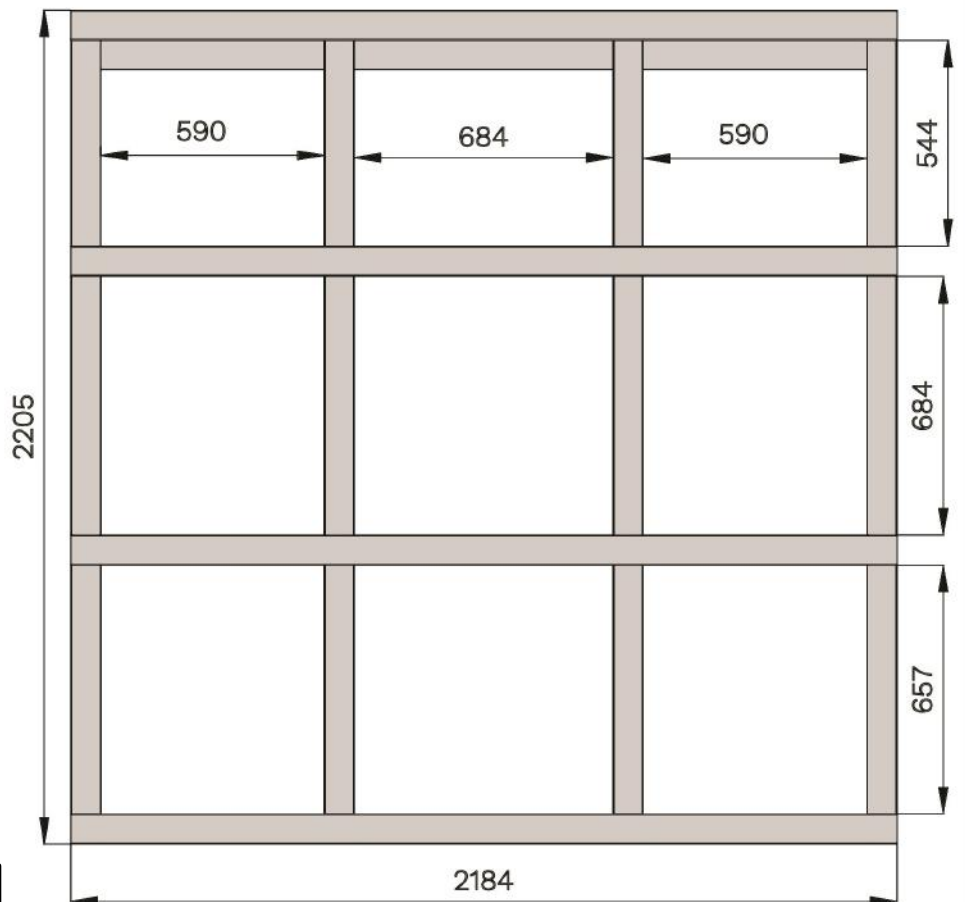

WC201161

17.

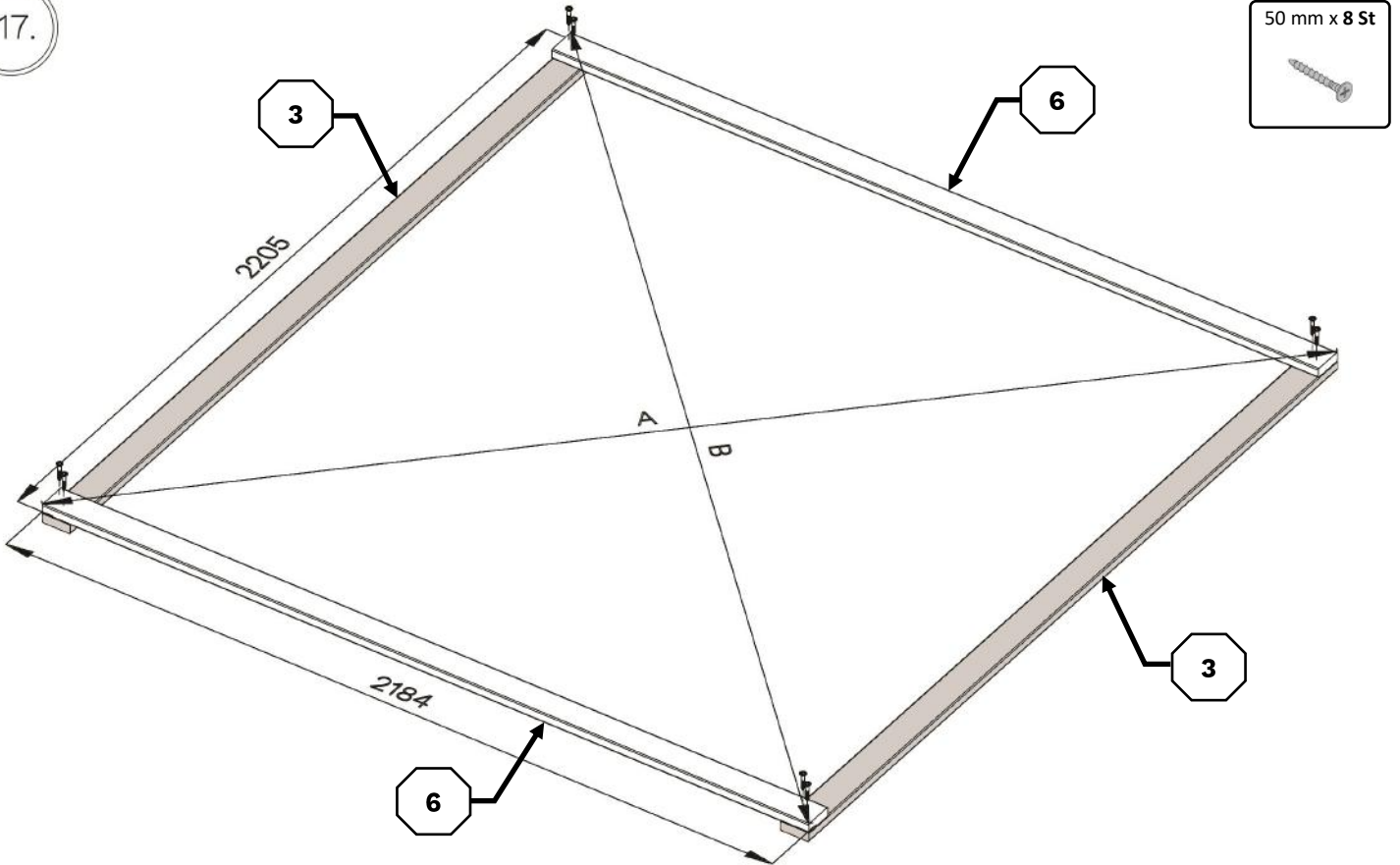

18.

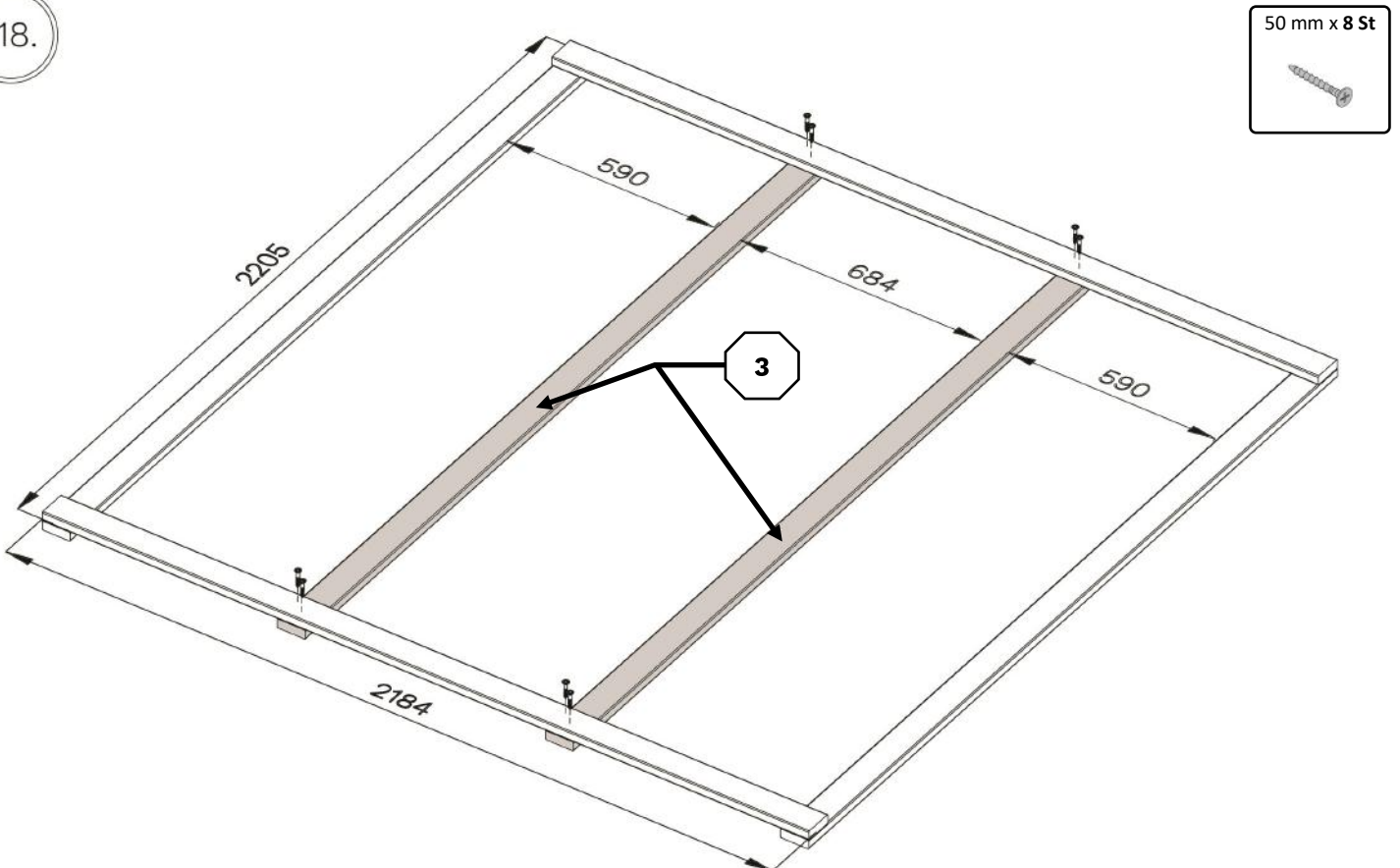

WC201161

19.

50 mm x 16 St

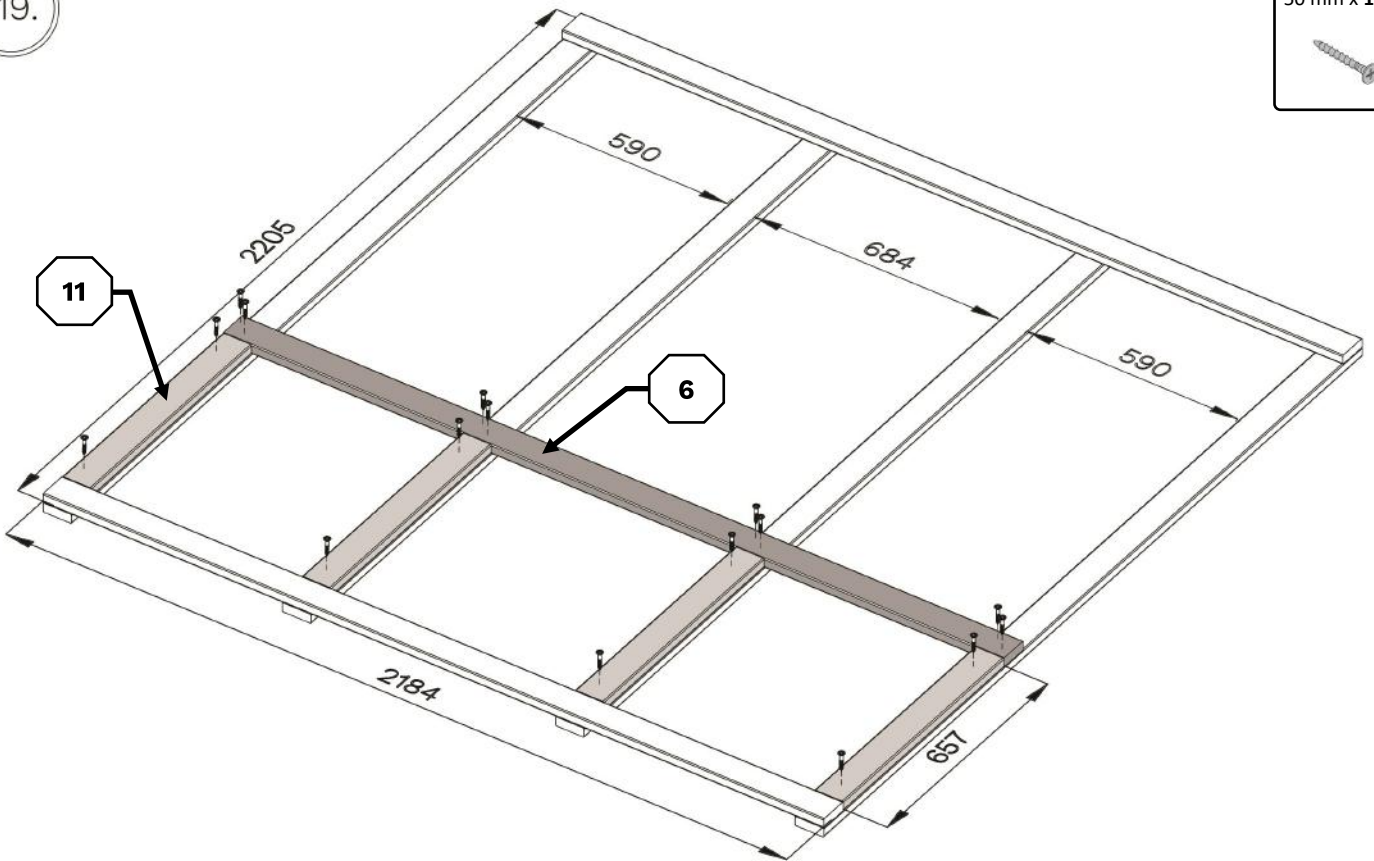

20.

50 mm x 24 St

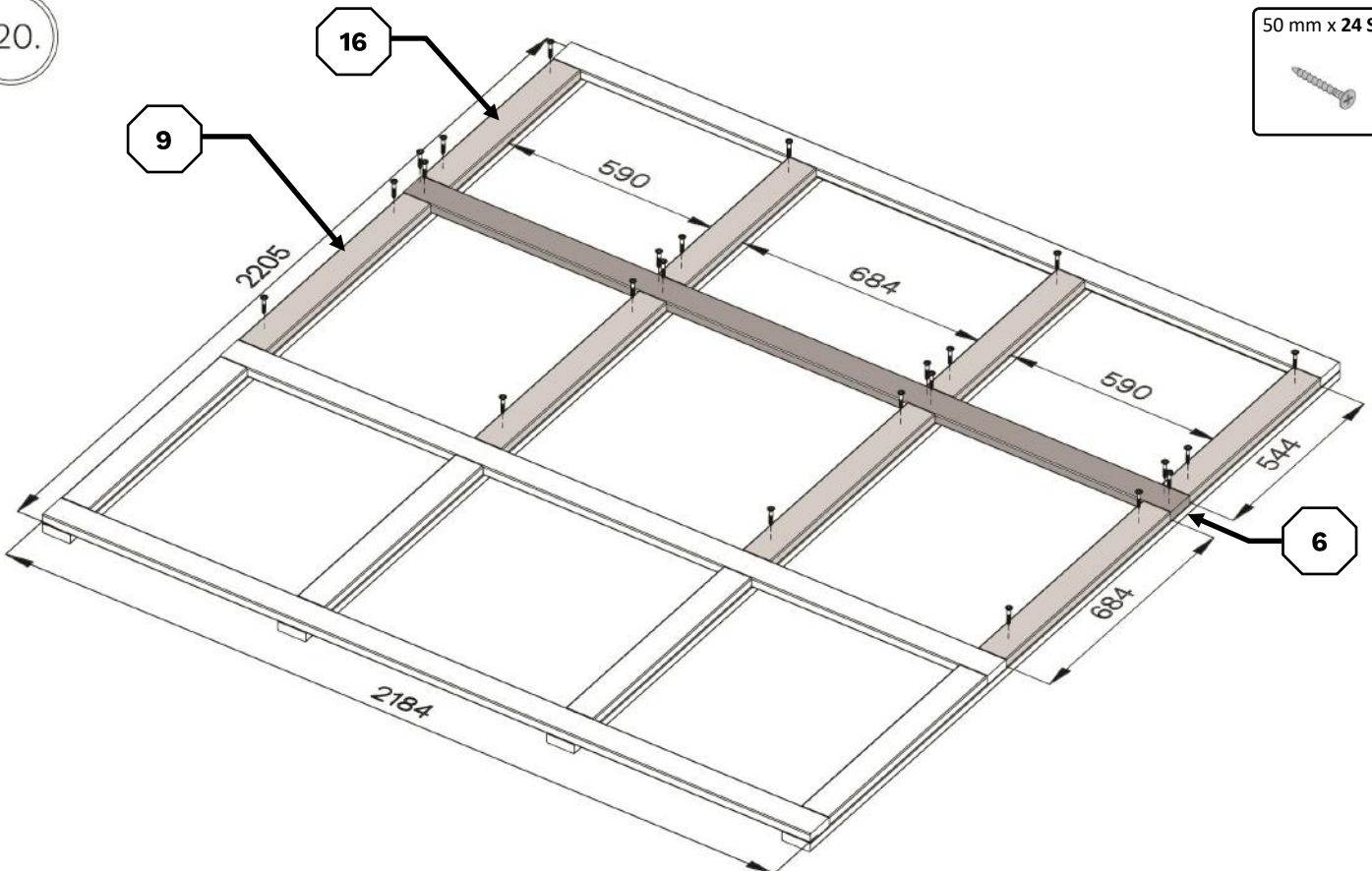

WC201161

21.

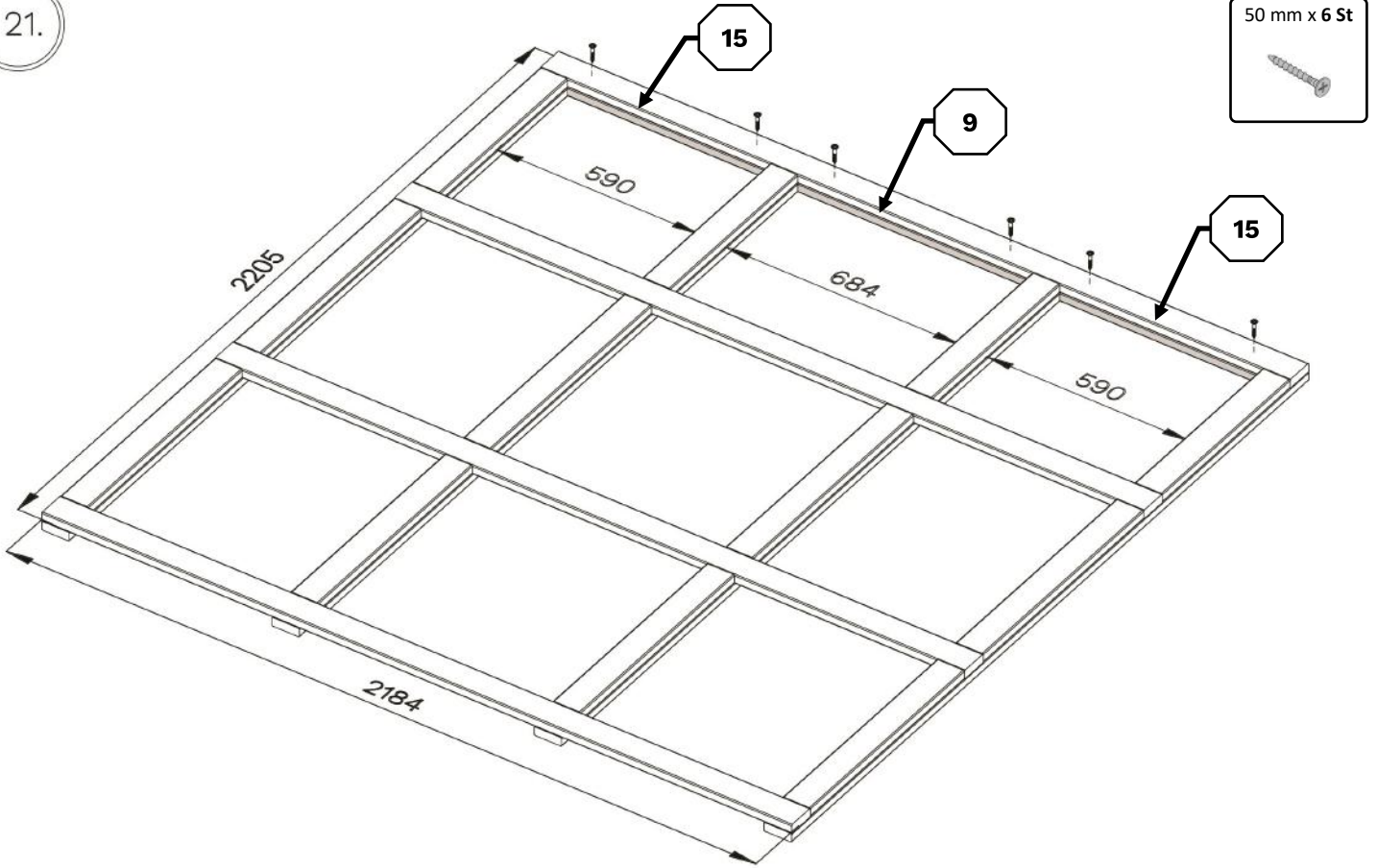

22.

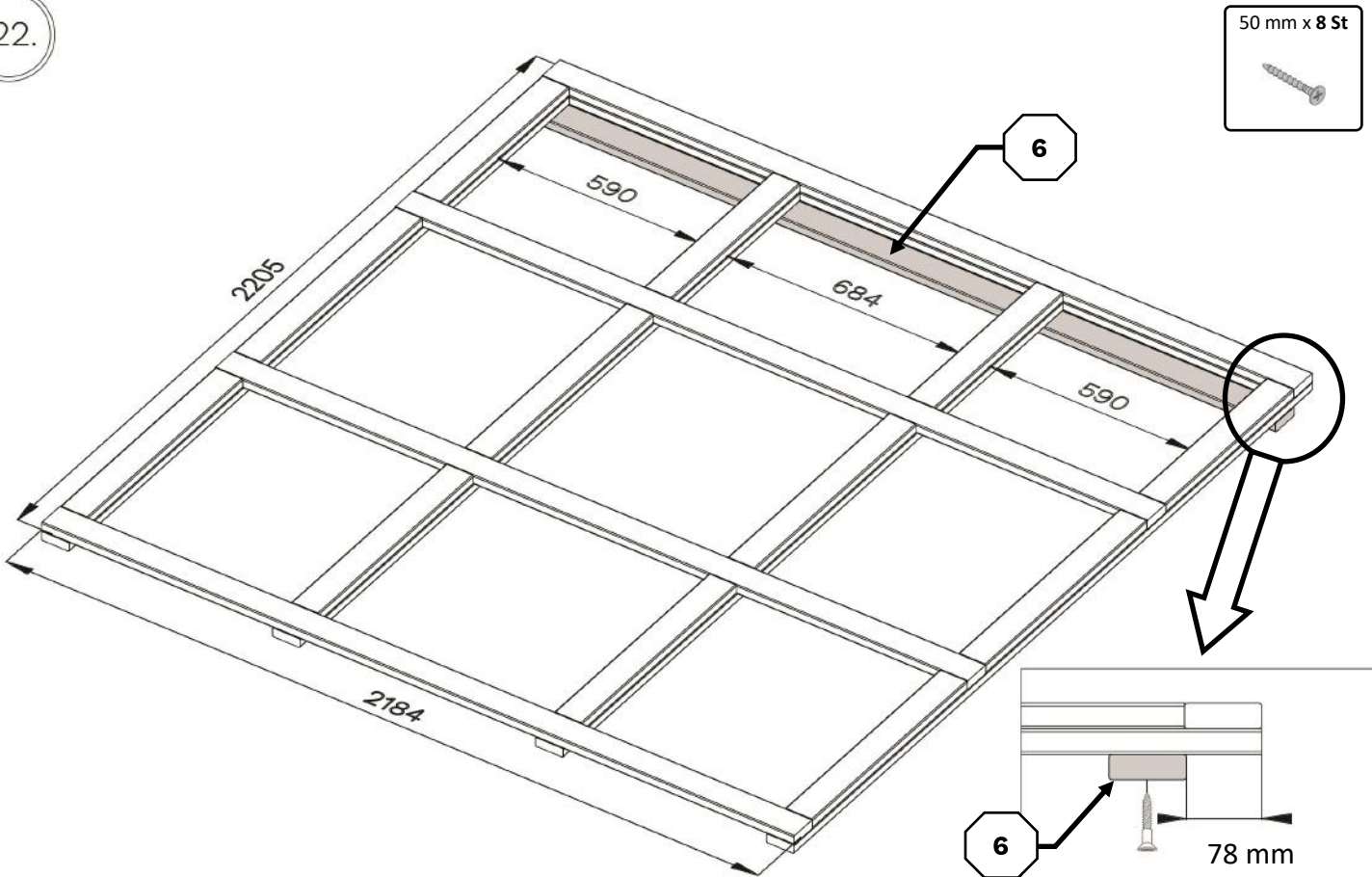

WC201161

23.

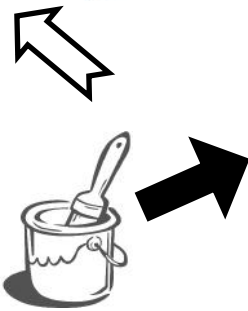
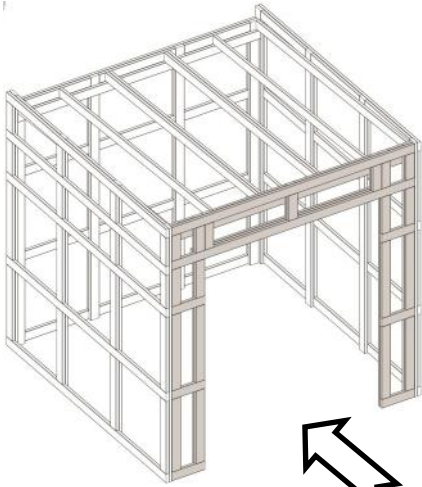

Holzschutzmittel / Wood preservative

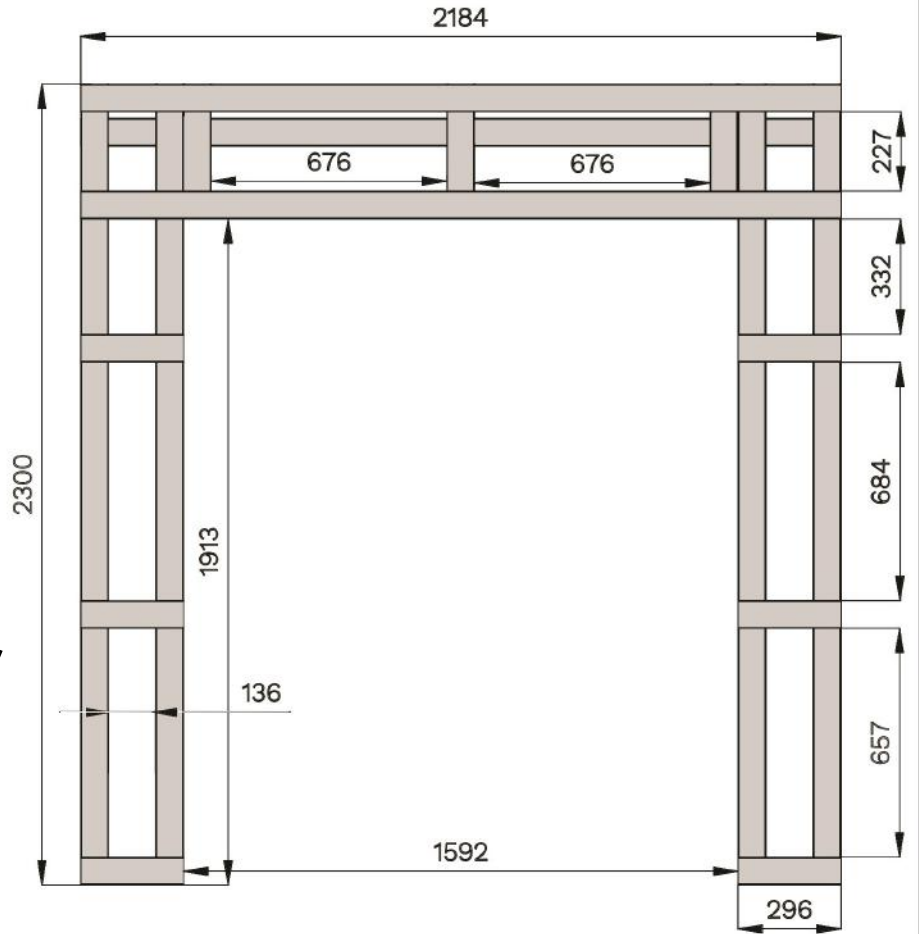

24.

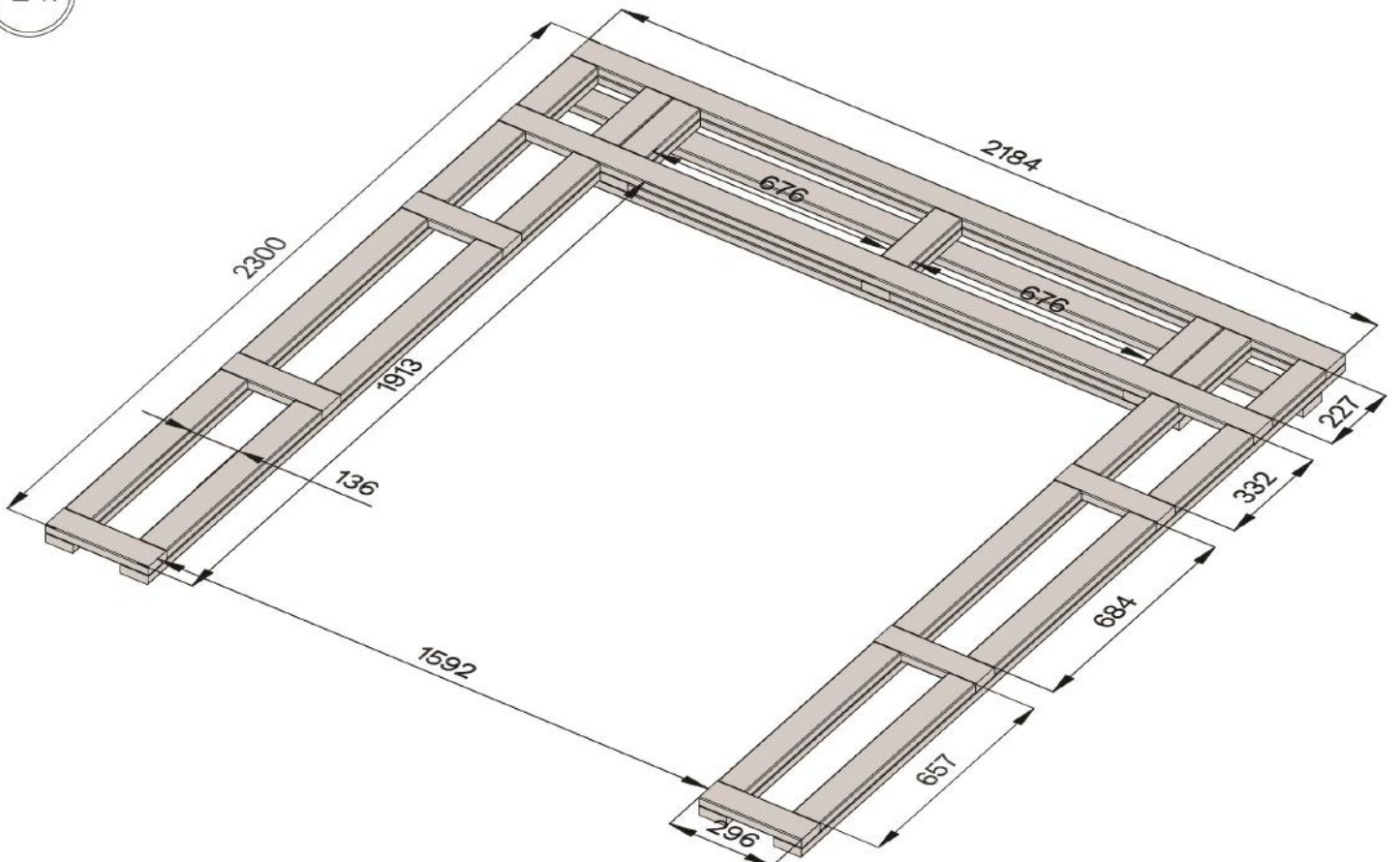

WC201161

25.

2X

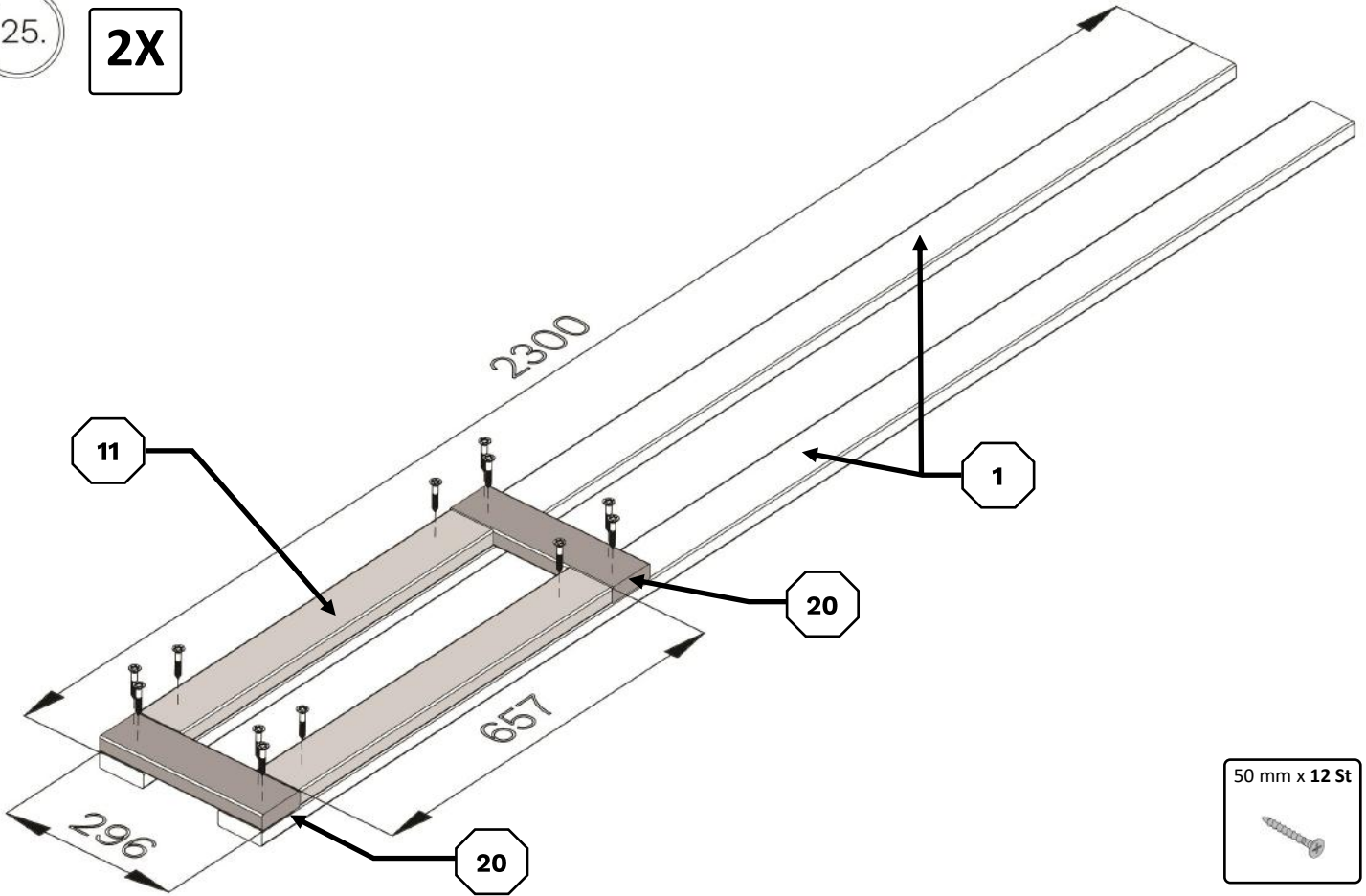

26.

2X

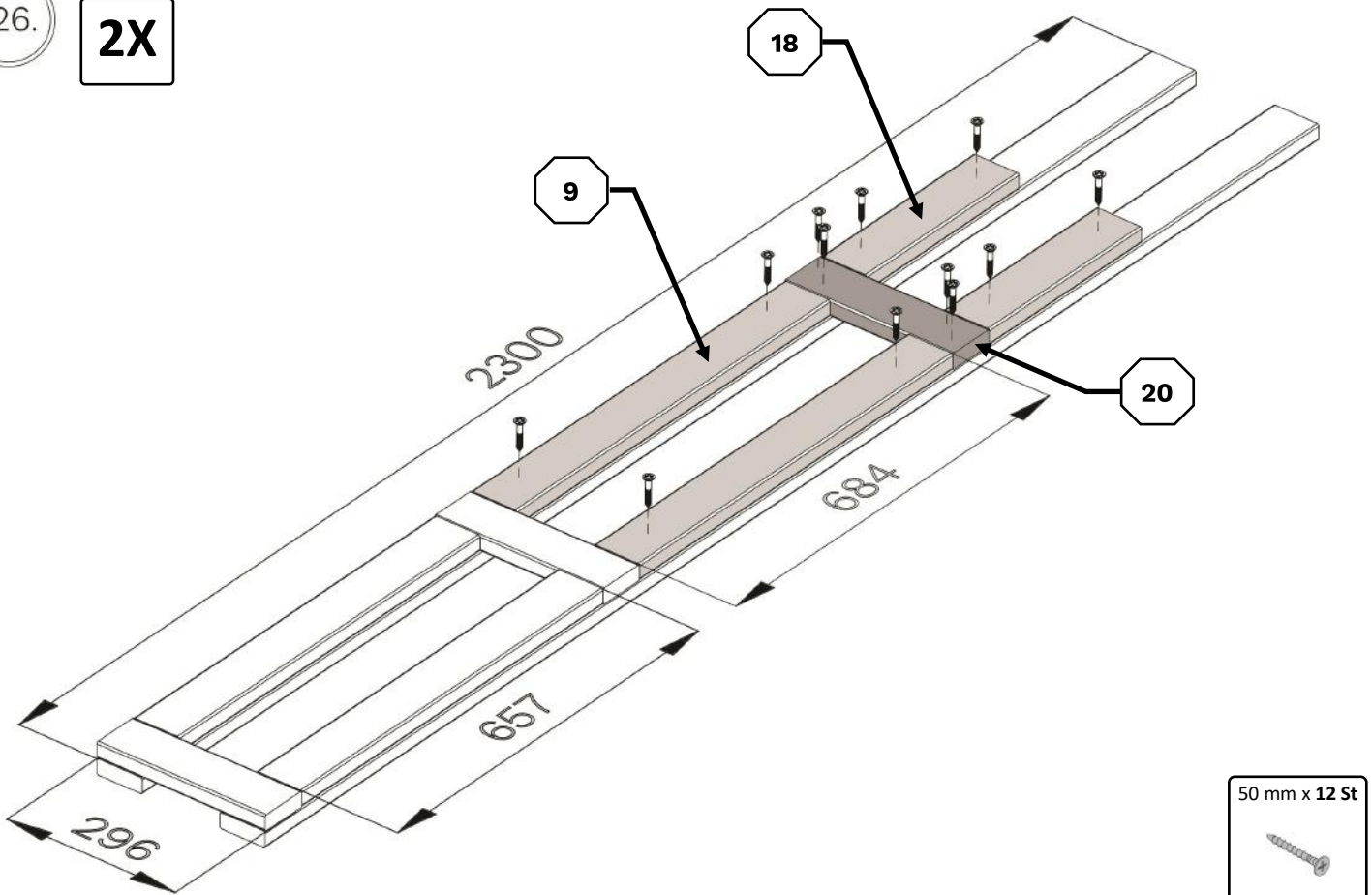

WC201161

27.

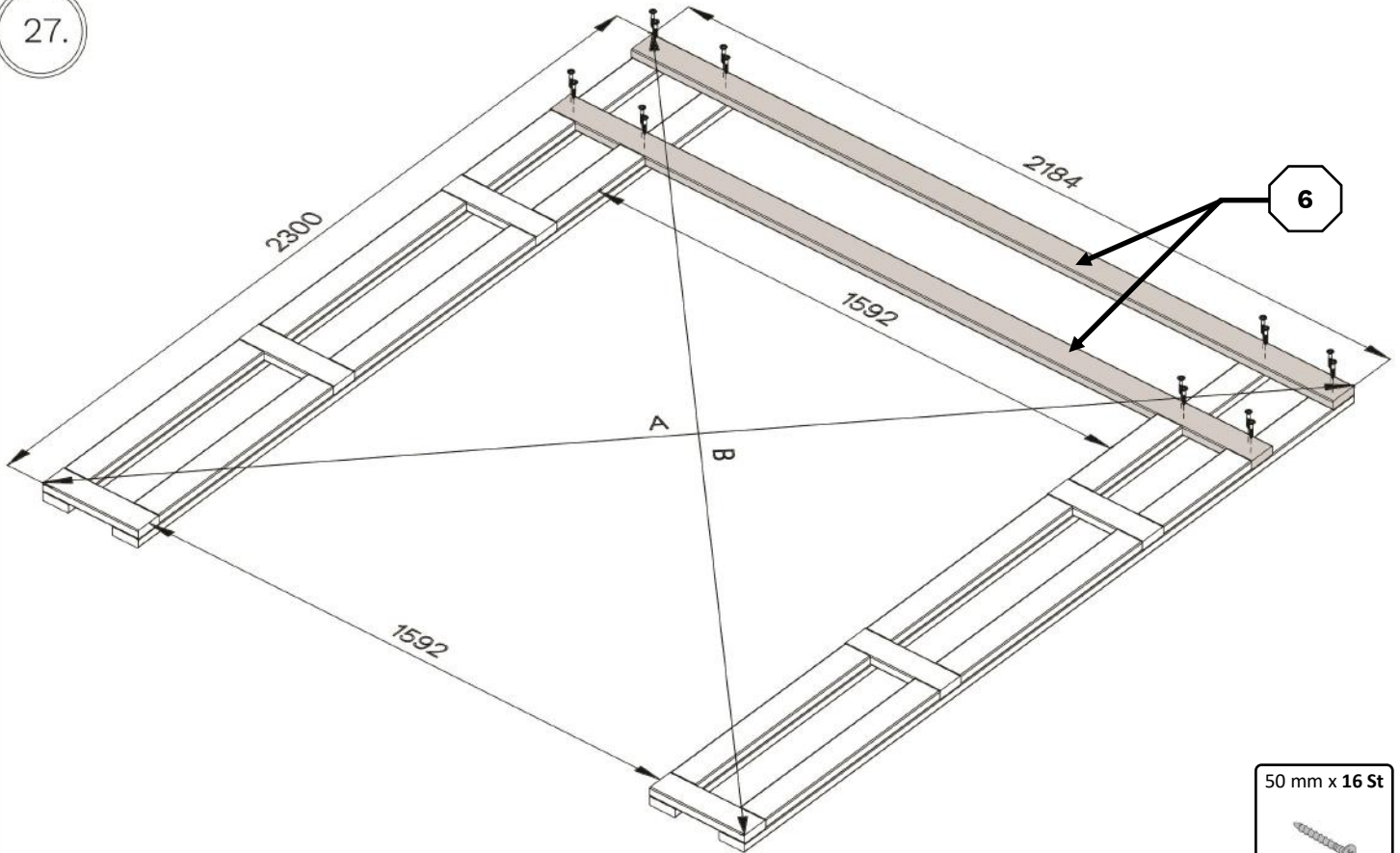

50 mm x 16 St



28.

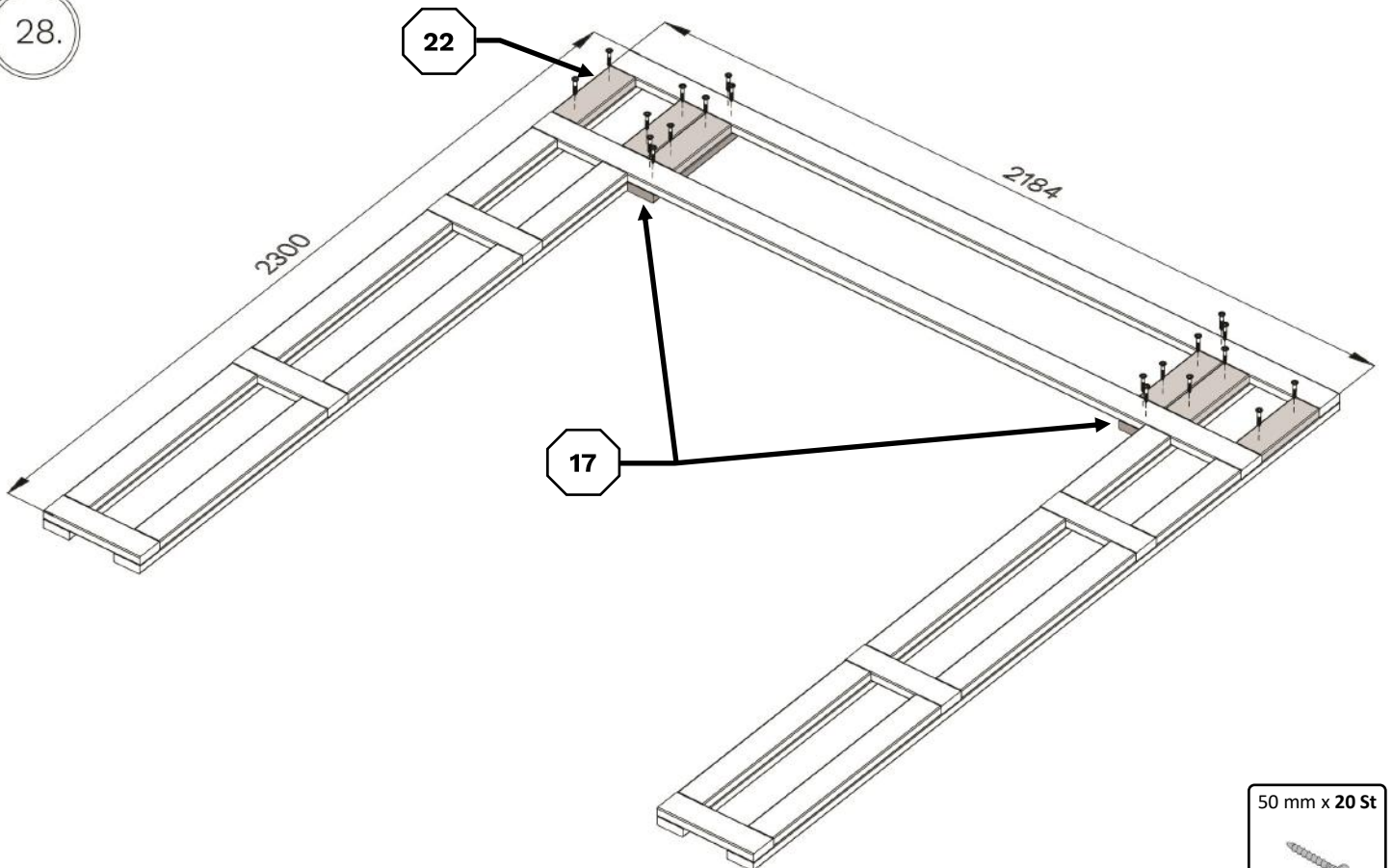

50 mm x 20 St



WC201161

29.

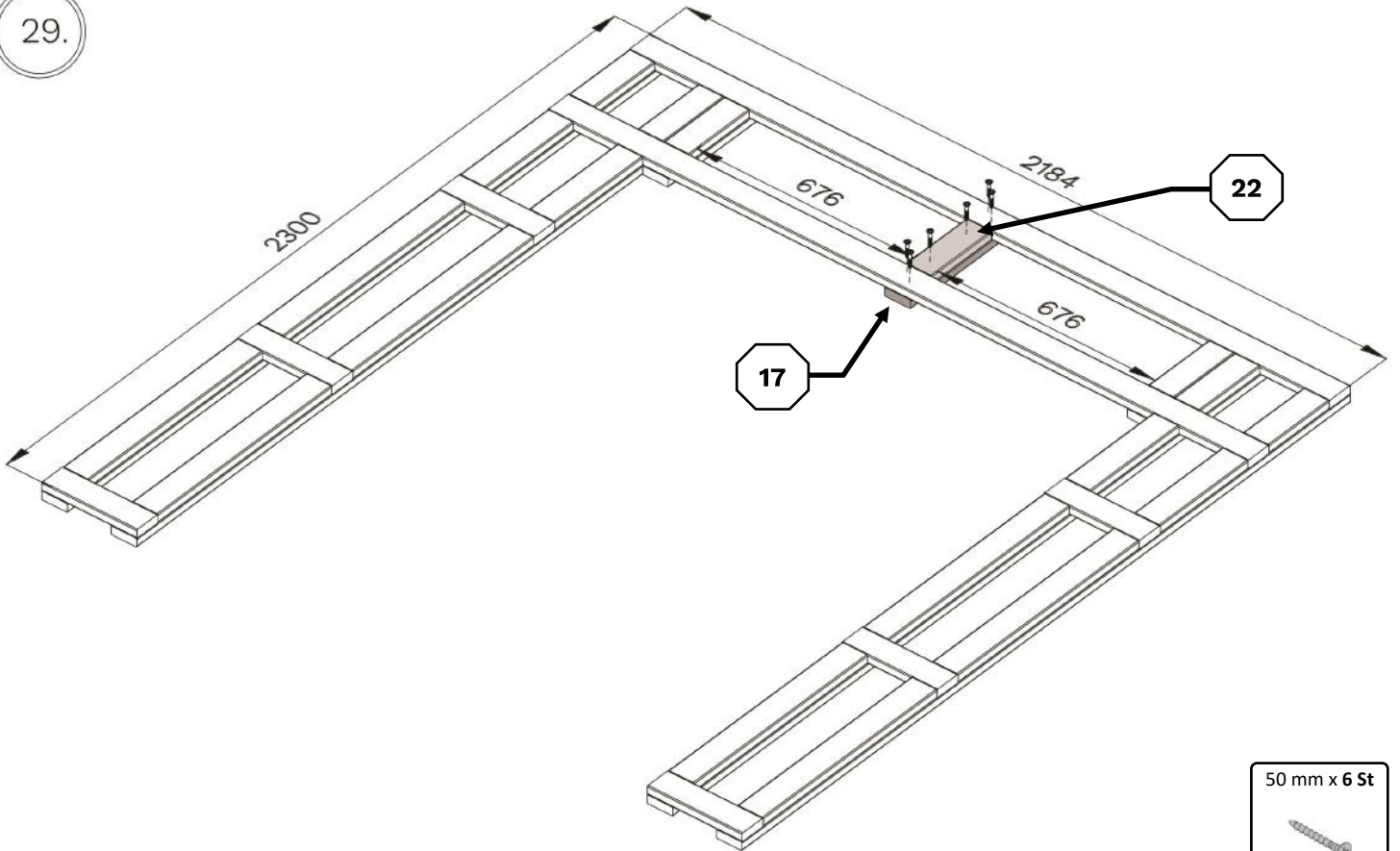

30.

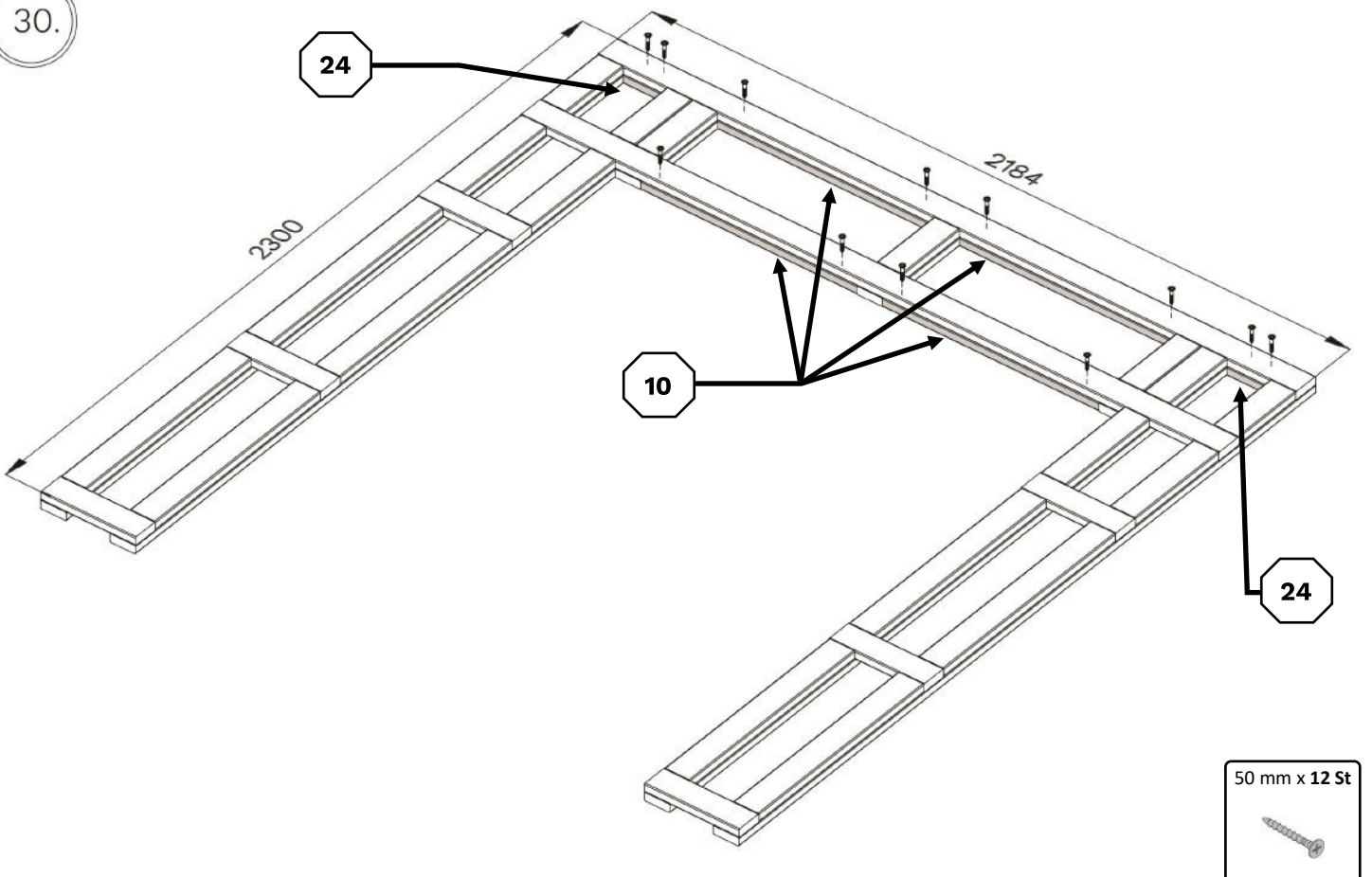

WC201161

31.

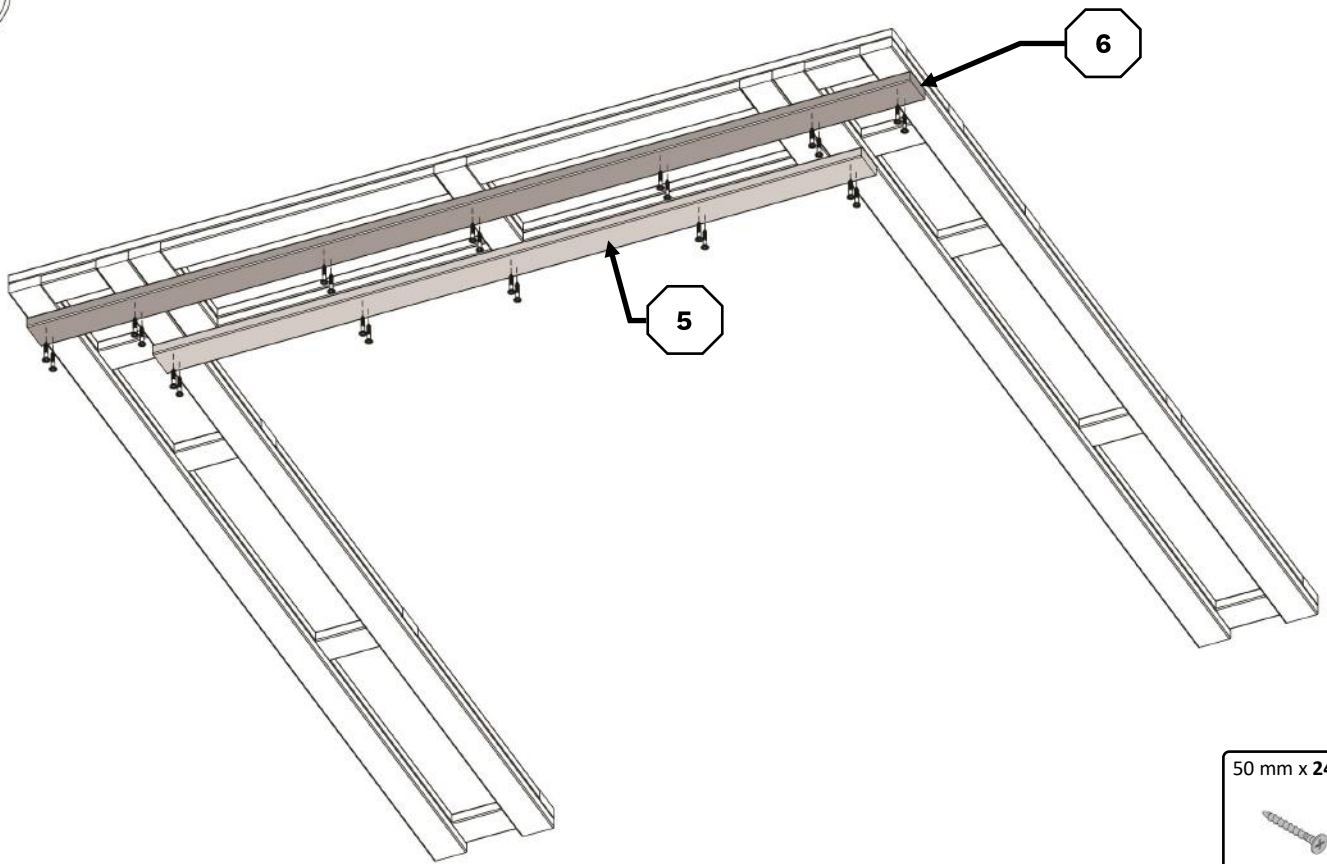

50 mm x 24 St



31.1

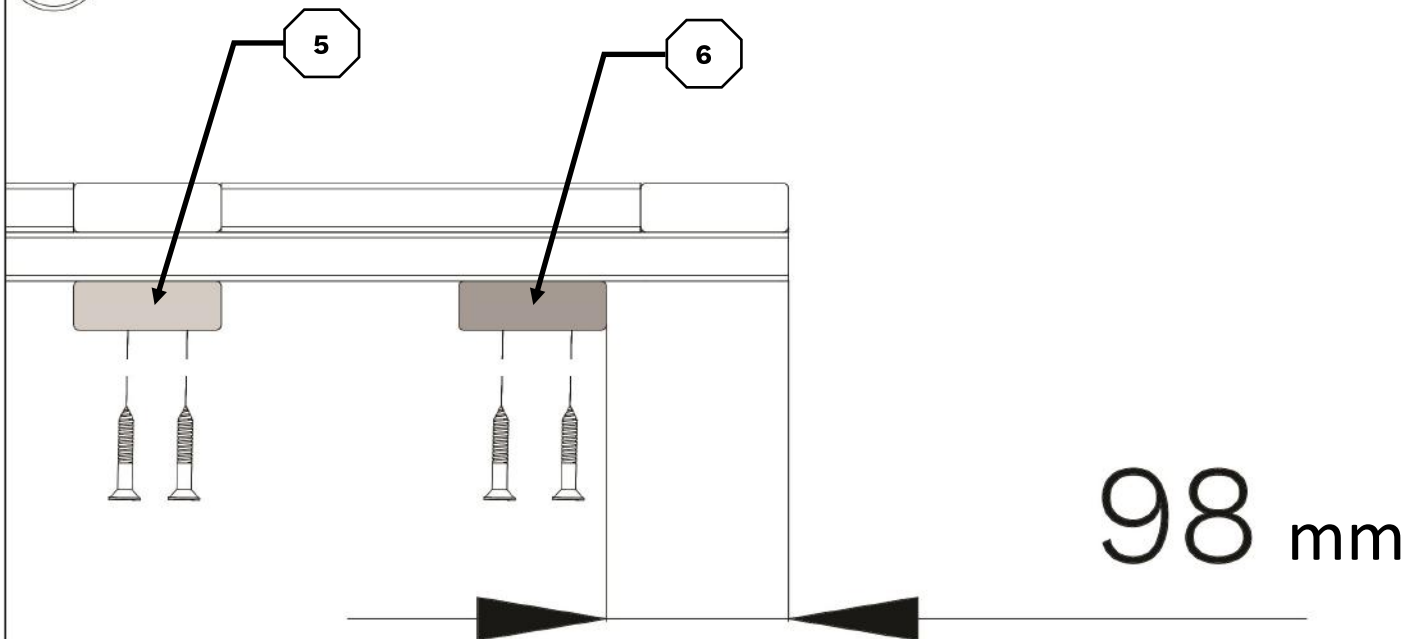

98 mm

NB!

Empfohlen bei Aufbau auf besonders feuchtem Untergrund. (**Nicht im Lieferumfang enthalten!**)

Recommended for assembly on moist ground. (**Not included!**)

* Unterlagspad /

* Patio Pads

Min. 9100 lfm/rmm



+€

* Imprägniert Kantholz /

* Impregnated beam

~40*60*9100 lfm/rmm



+€

* Schraube /

* Screw

5*120 mm

8 Stck/Pcs



+€

Fundamentplan / Foundation Plan

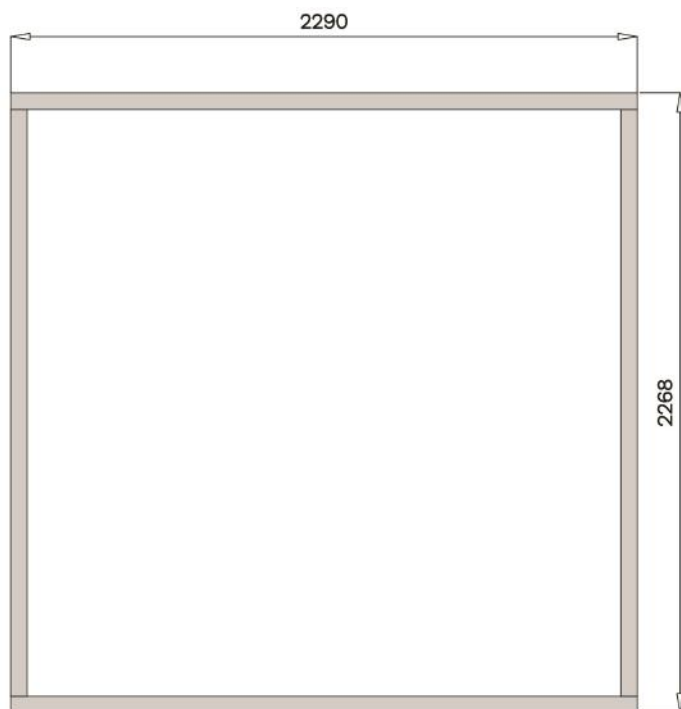

Imprägniertes Kantholz /
Impregnated beam

Unterlagspad /
Patio pads

Der Untergrund /
Ground

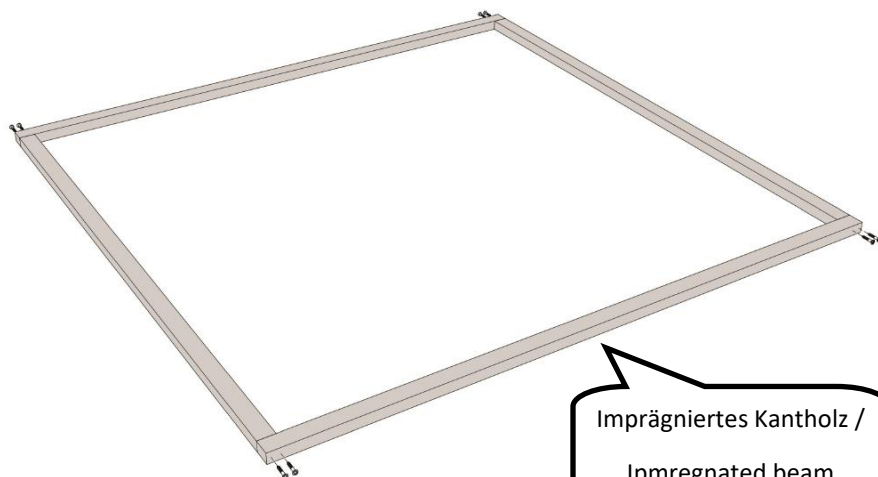

Vor dem Aufbau!

Erkundigen Sie sich vor der Montage, ob für den Bau eine Genehmigung erforderlich ist.

Before installation!

Prior to assembly please check whether a permission is required.

WC201161

32.

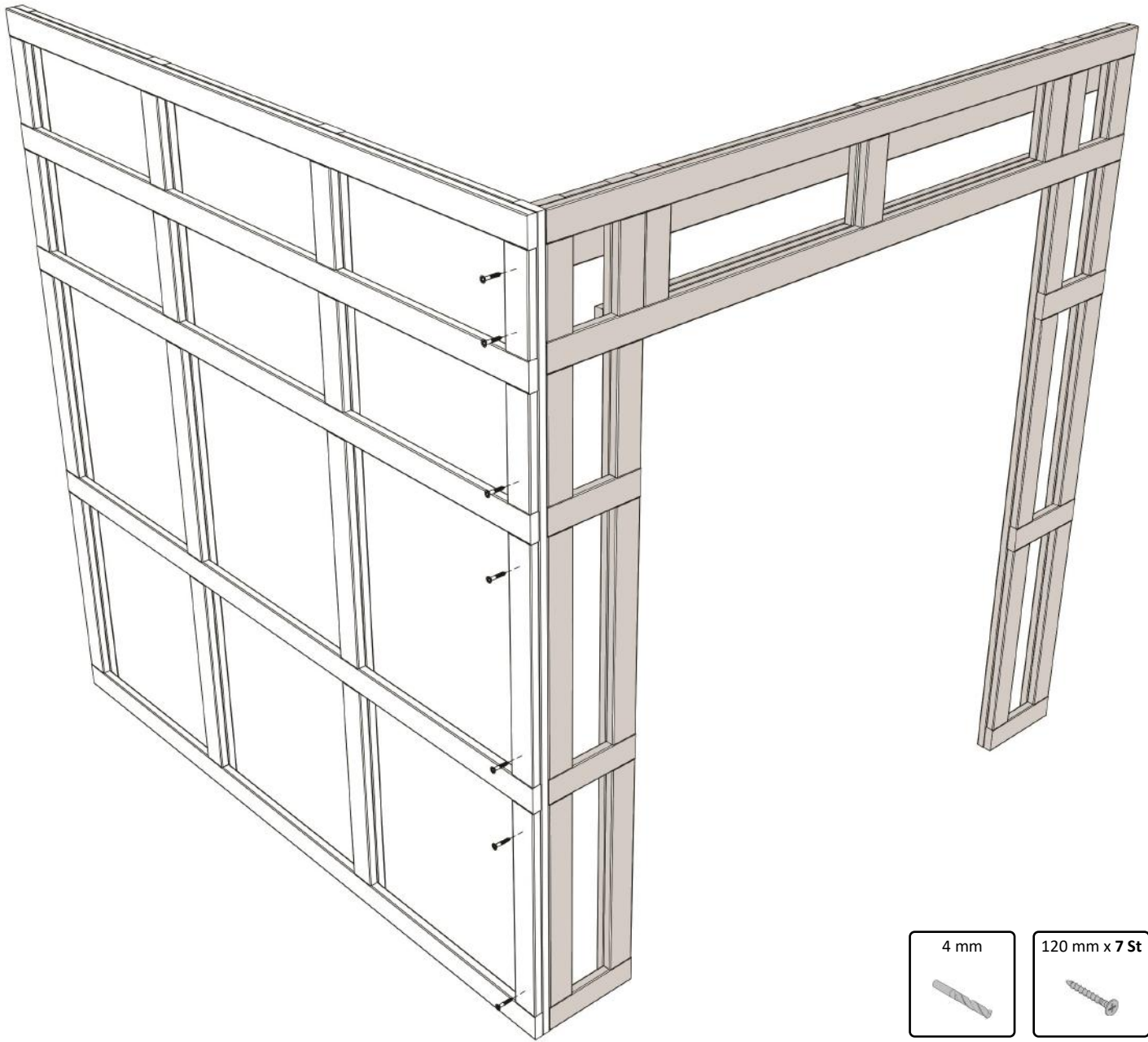

4 mm



120 mm x 7 St



32.1



WC201161

33.

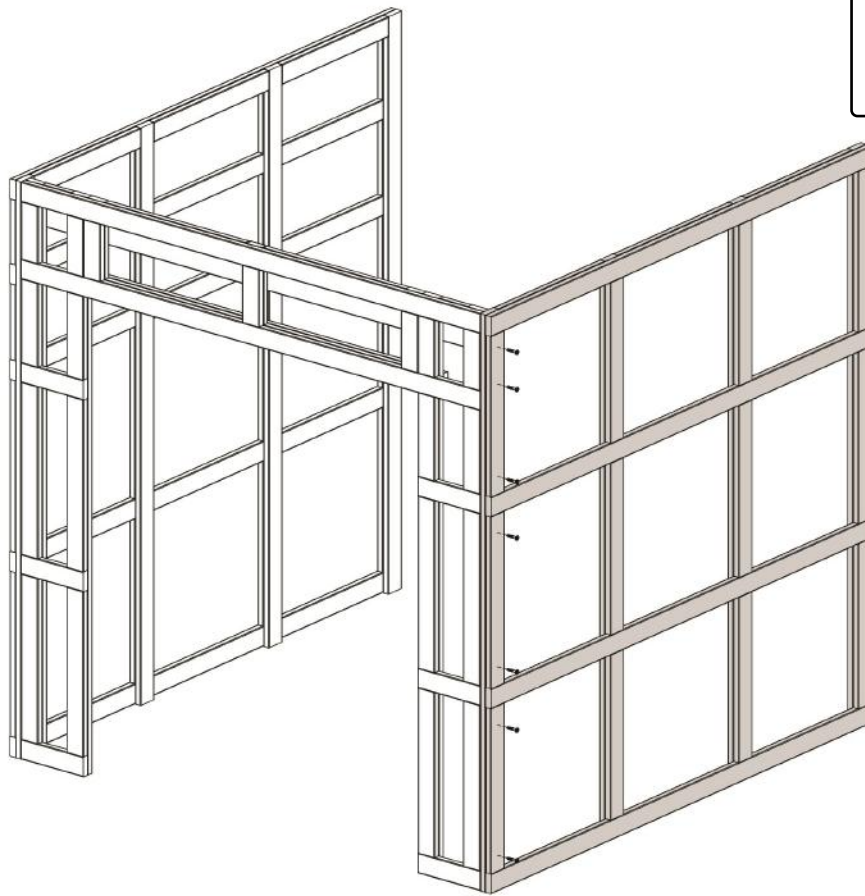

4 mm



120 mm x 7 St

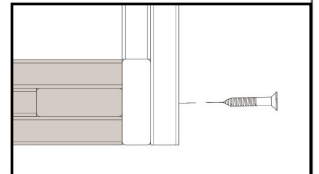

34.

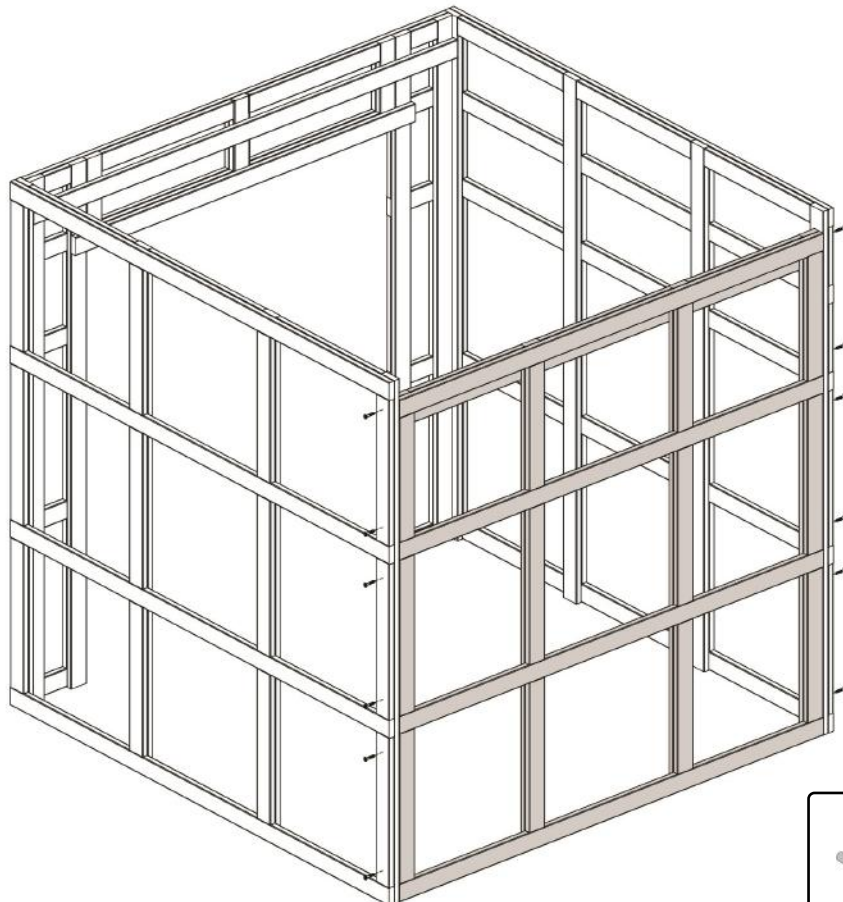

4 mm



120 mm x 14 St

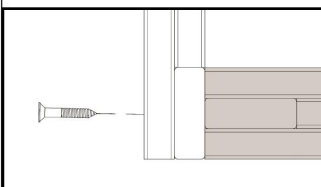

WC201161

35.

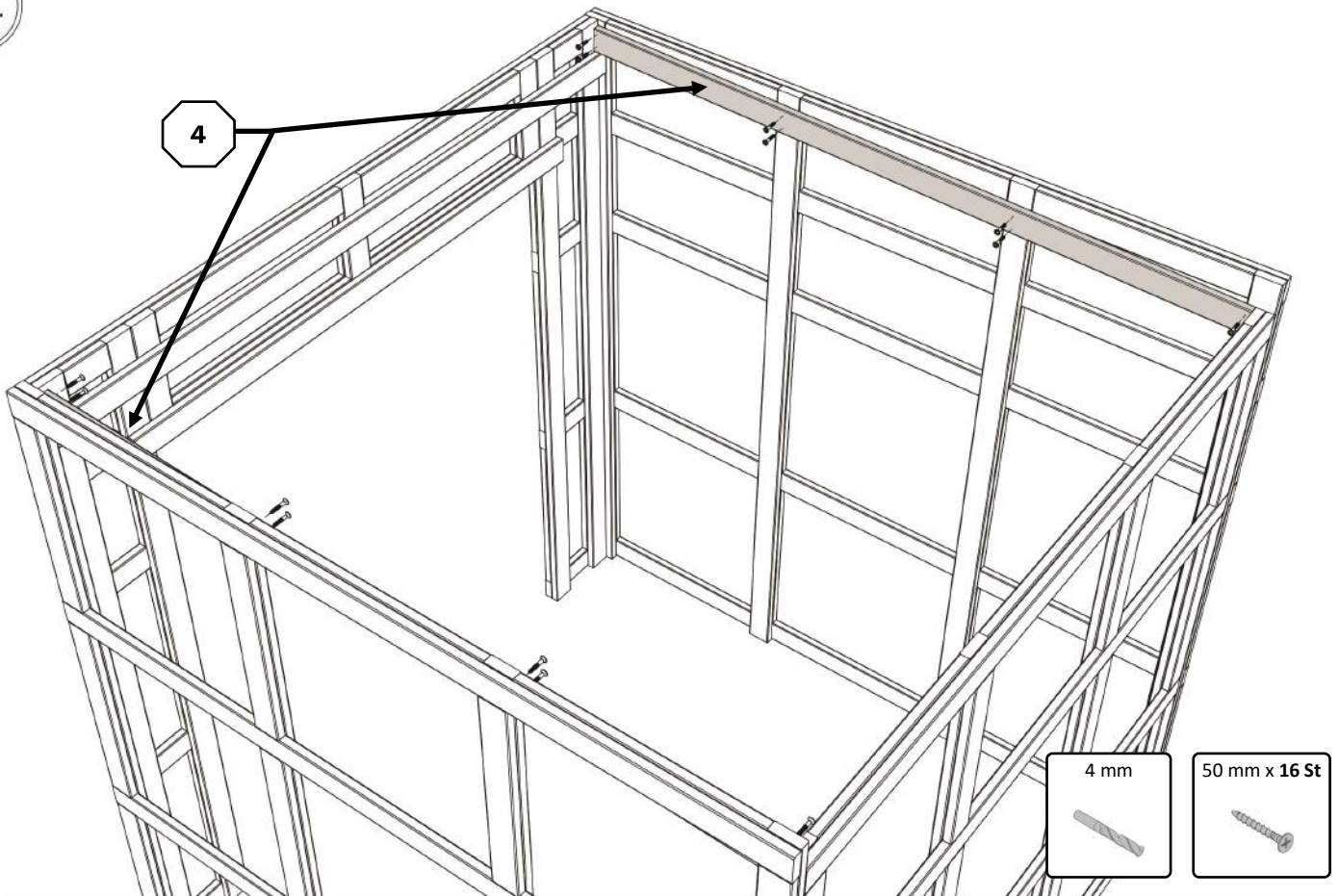

35.1



36.

2X

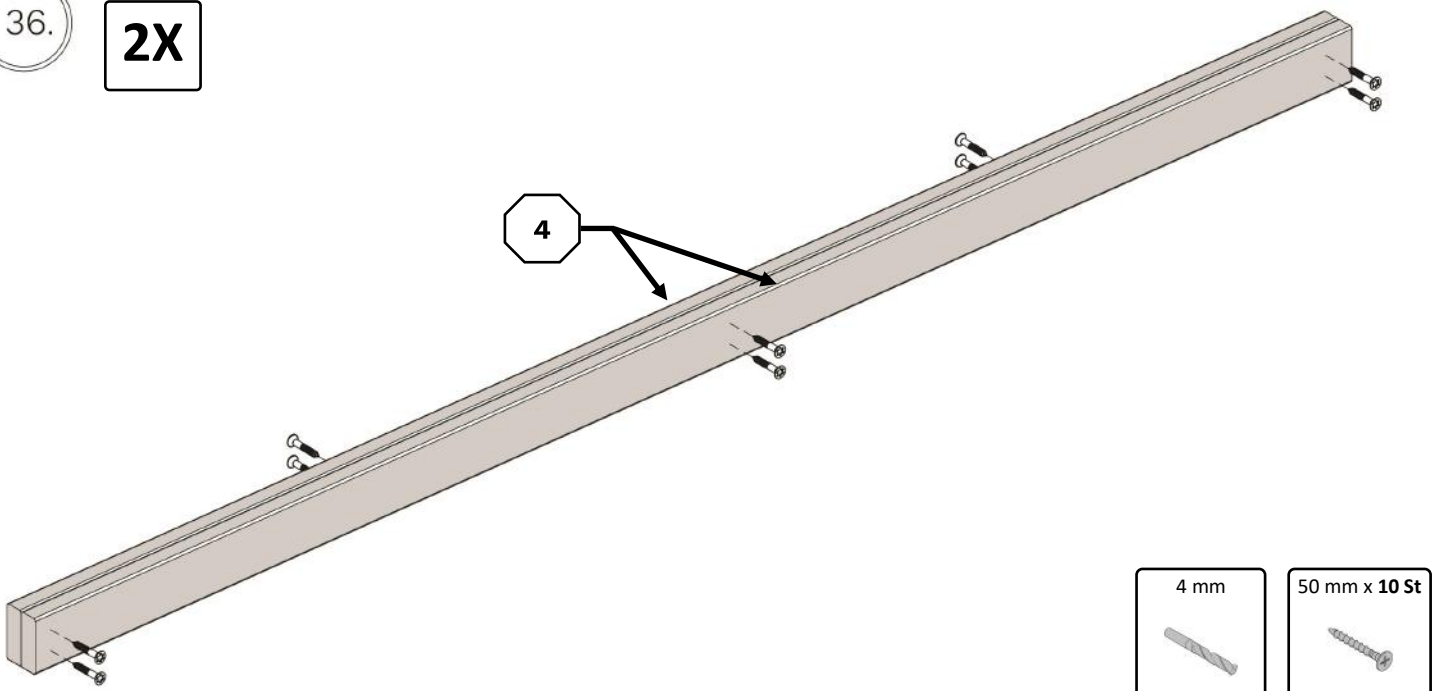

WC201161

37.

4 mm

120 mm x 16 St



4

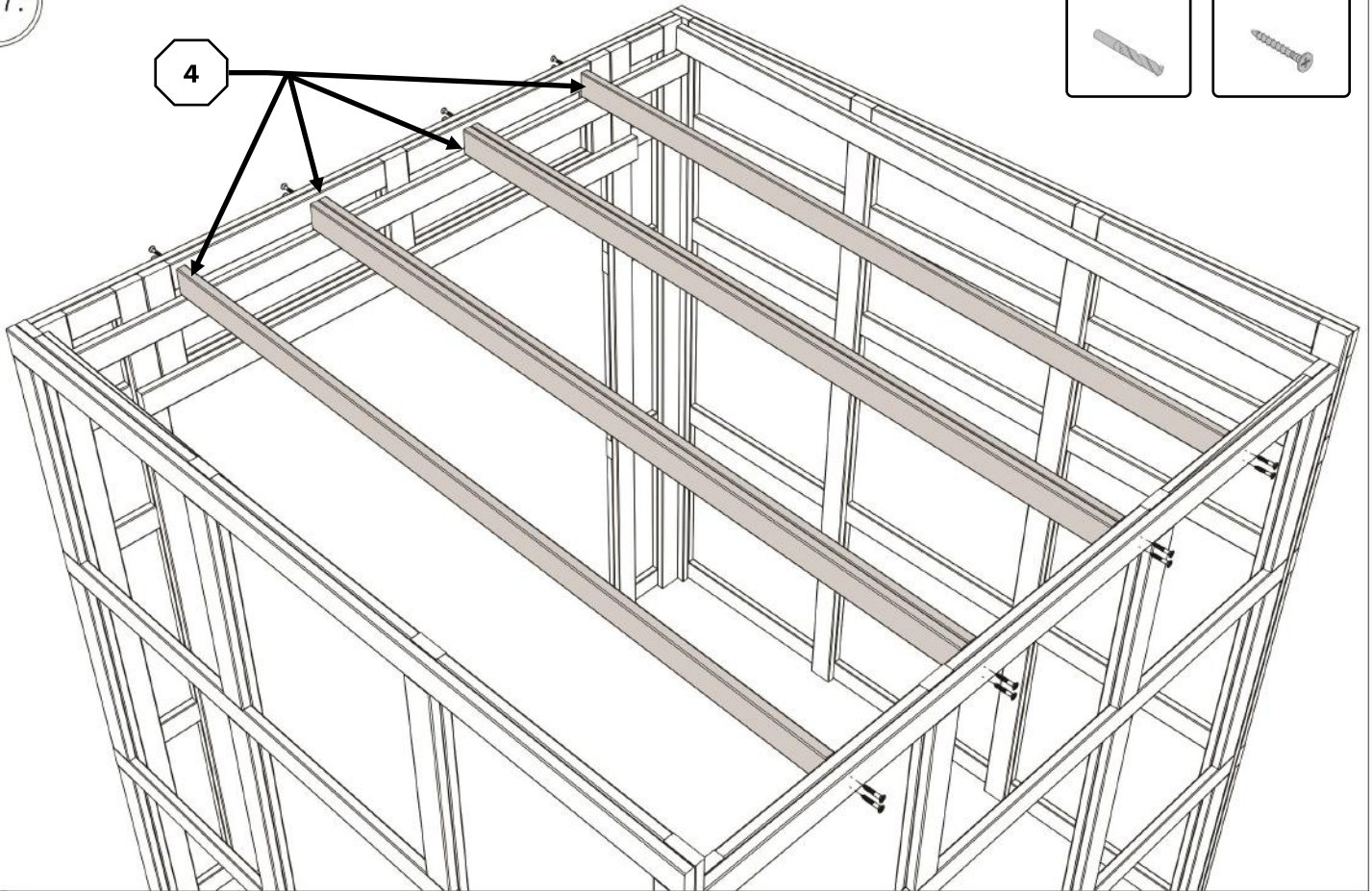

37.1

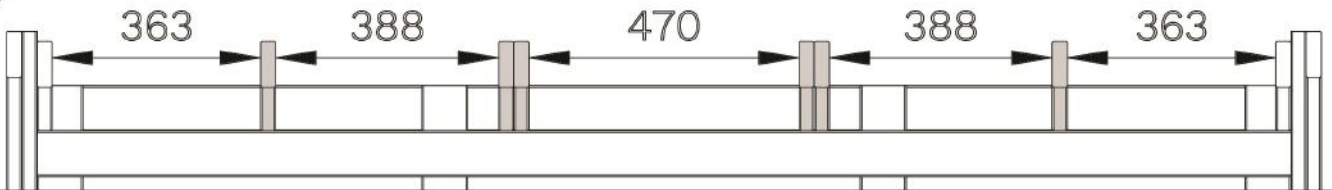

37.2

4

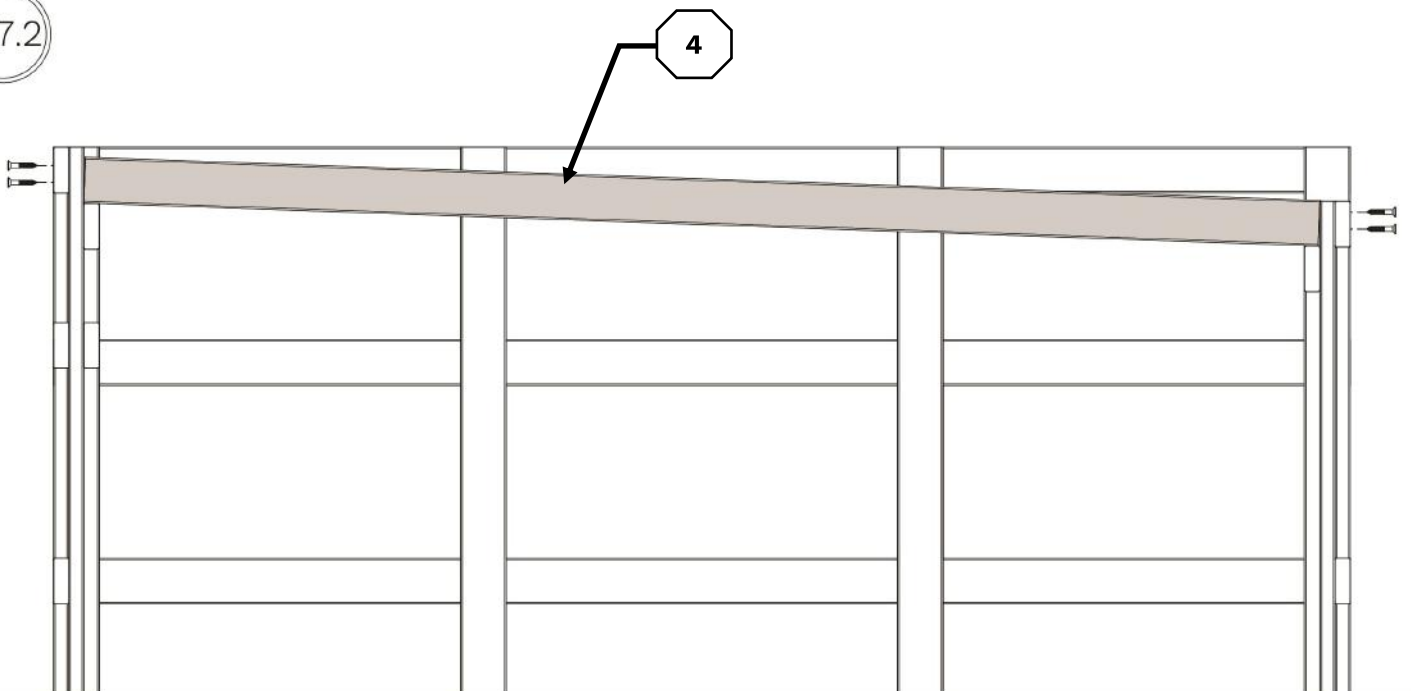

WC201161

38.

4 mm



75 mm x 8 St

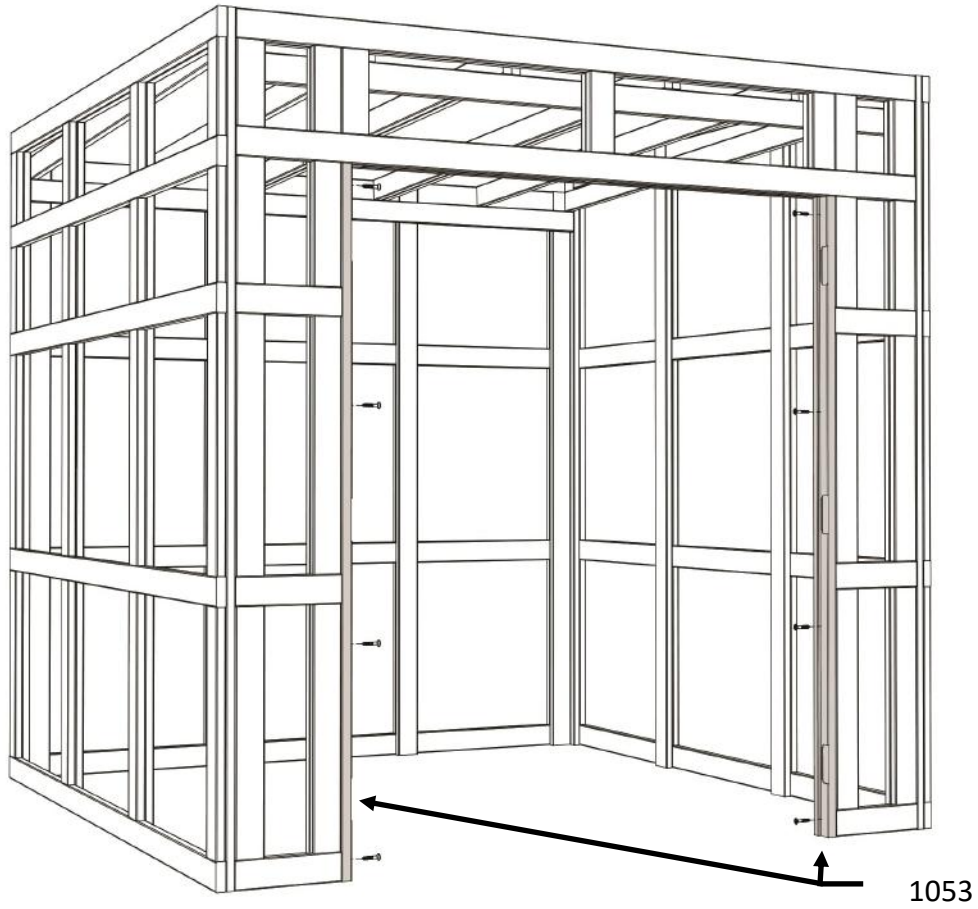

1053

38.1



1053

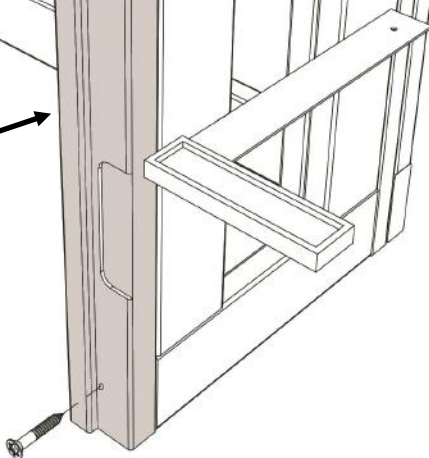

39.

6X

50 mm x 4 St

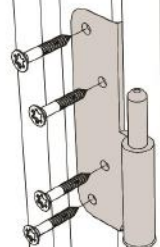

1527

1555

WC201161

40.

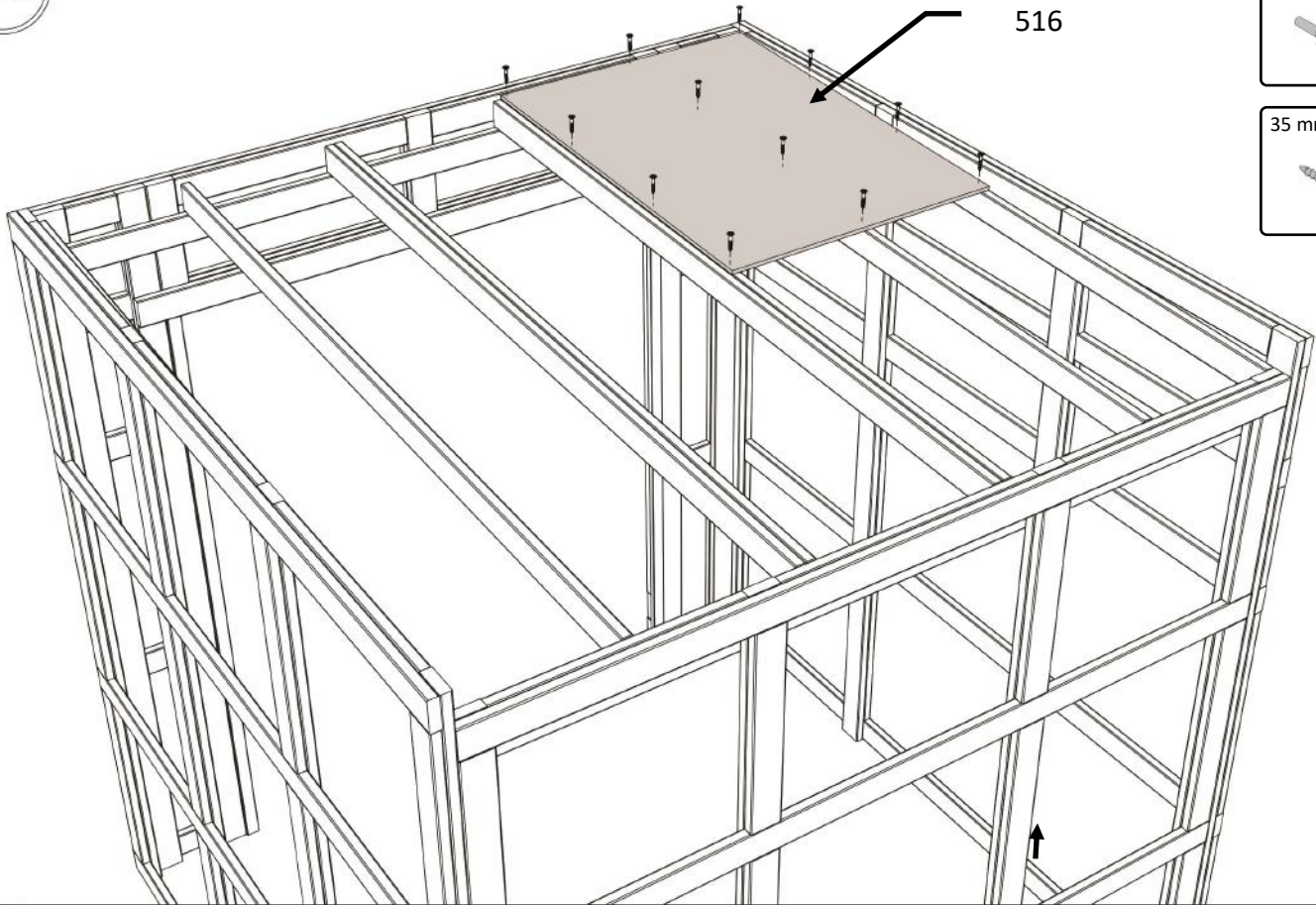

4 mm



35 mm x 12 St



41.

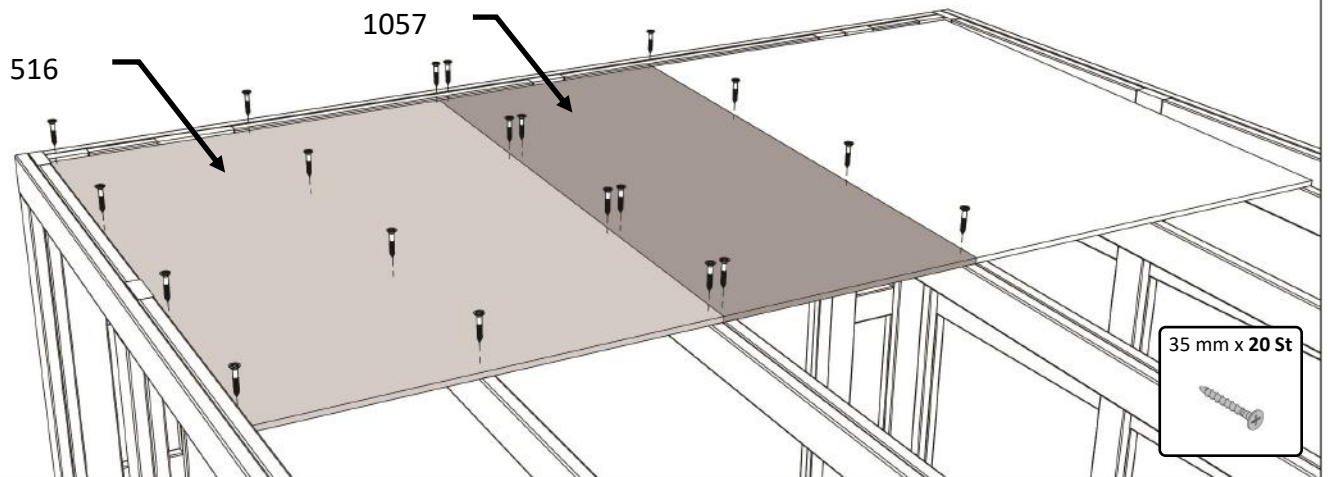

35 mm x 20 St



42.

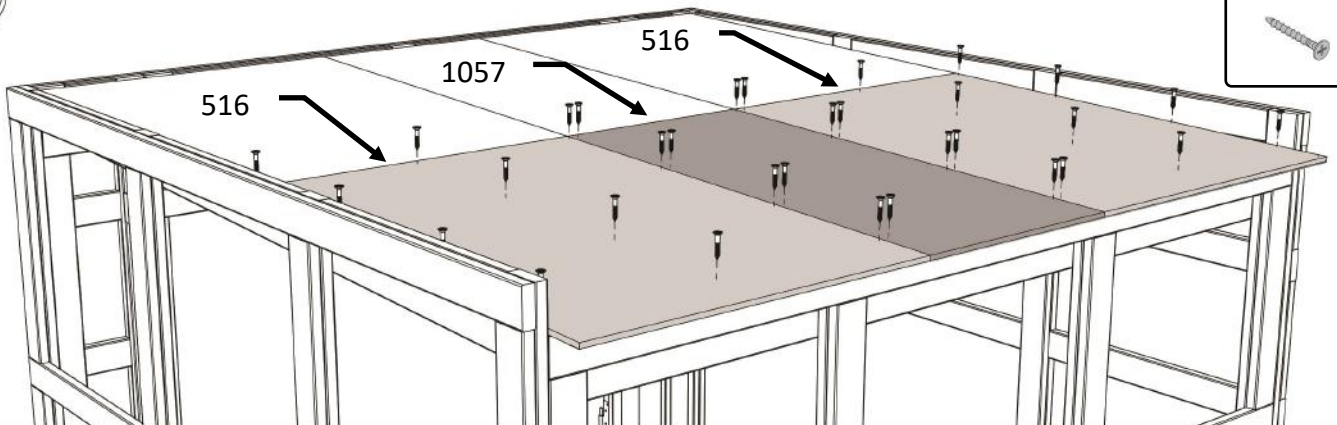

35 mm x 32 St



WC201161



2 Hours

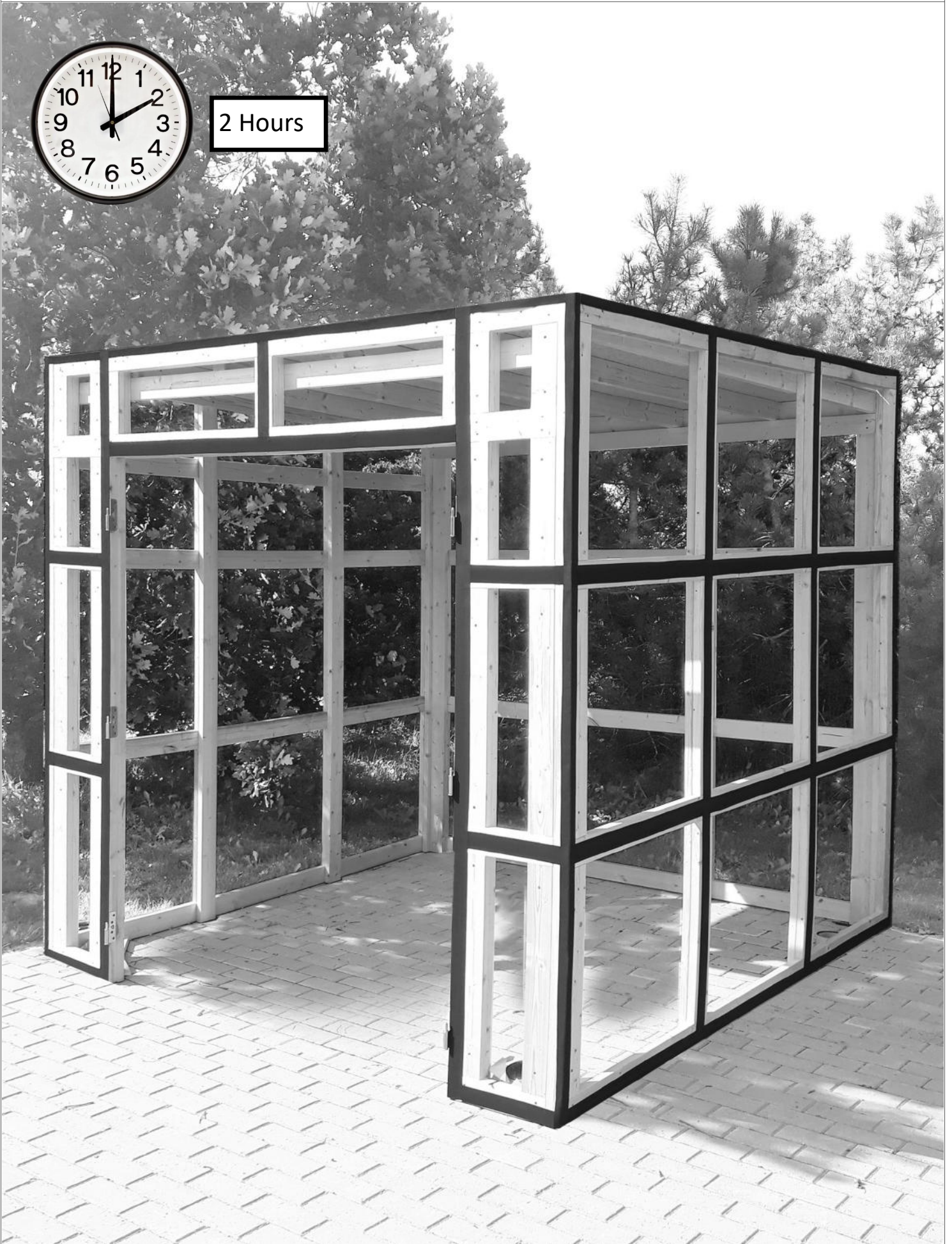

WC201161

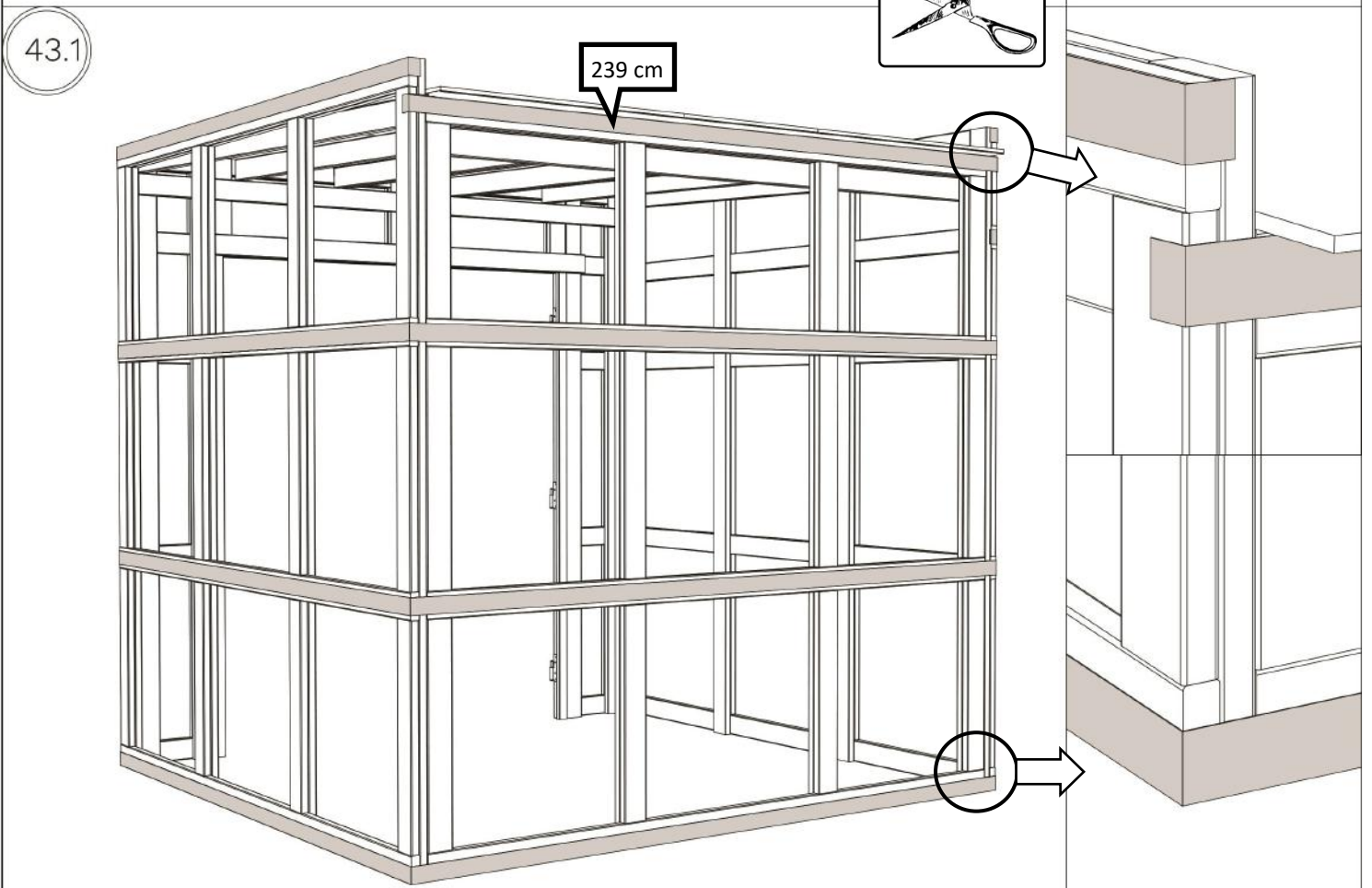
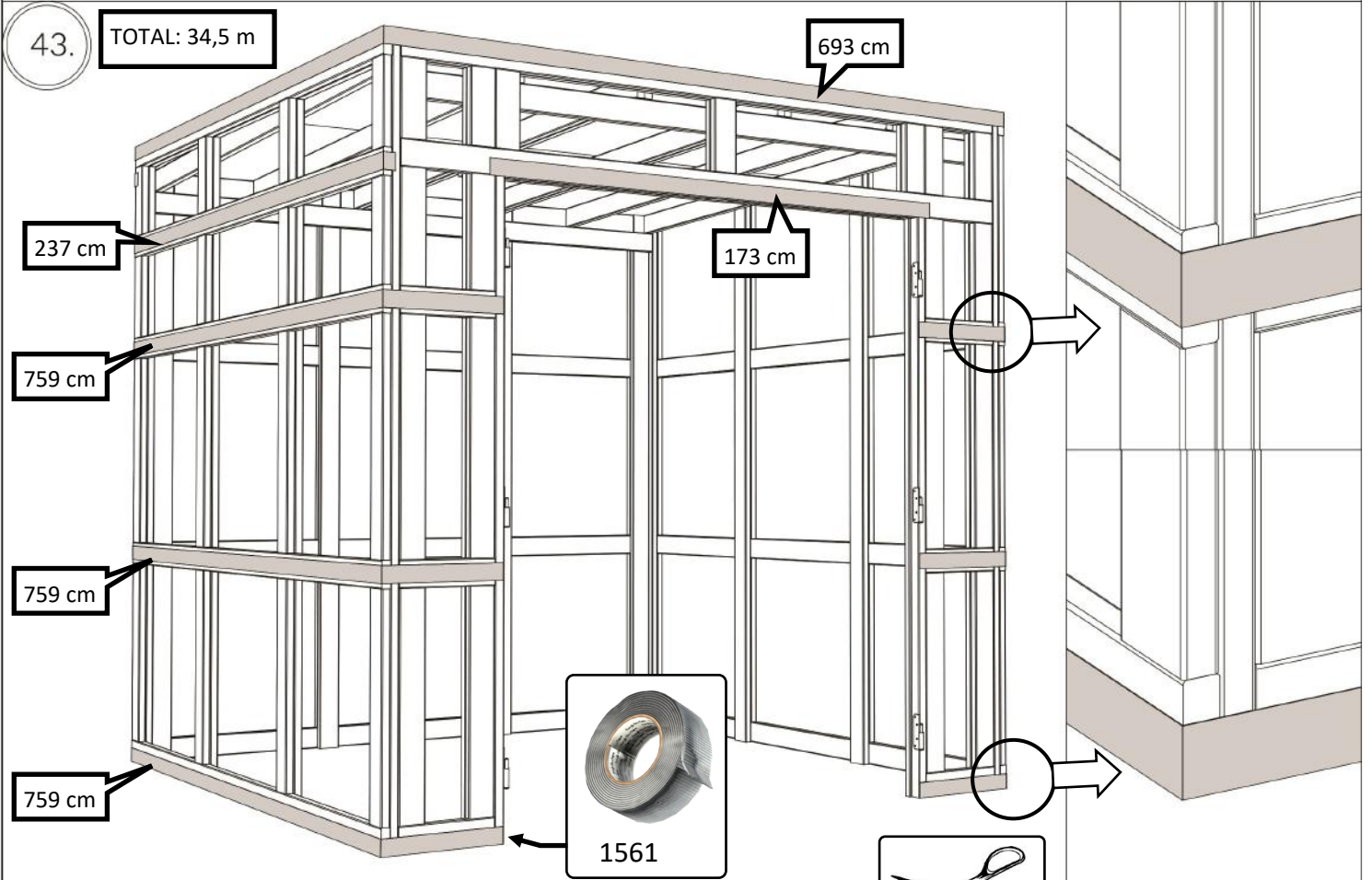

WC201161

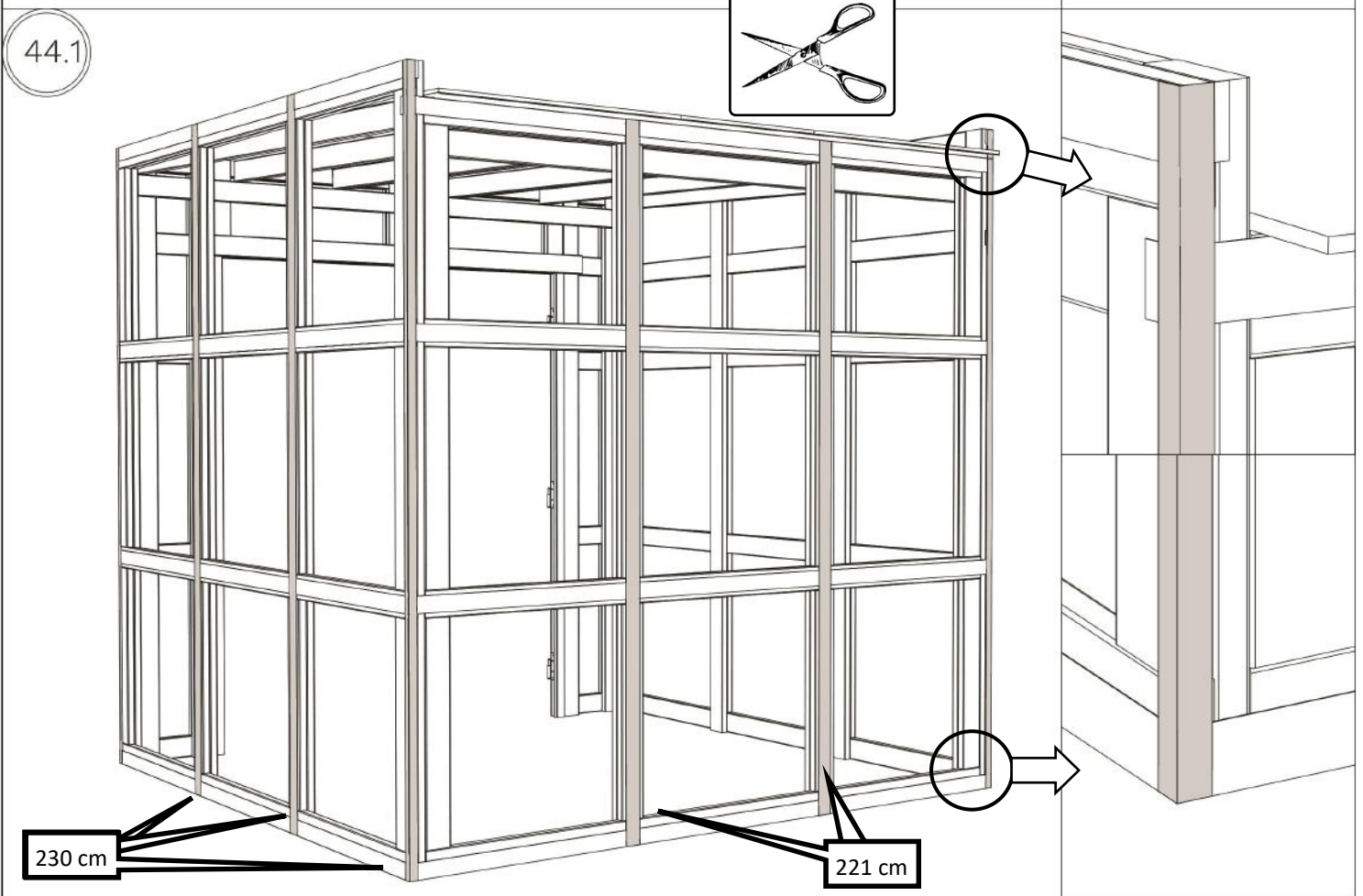
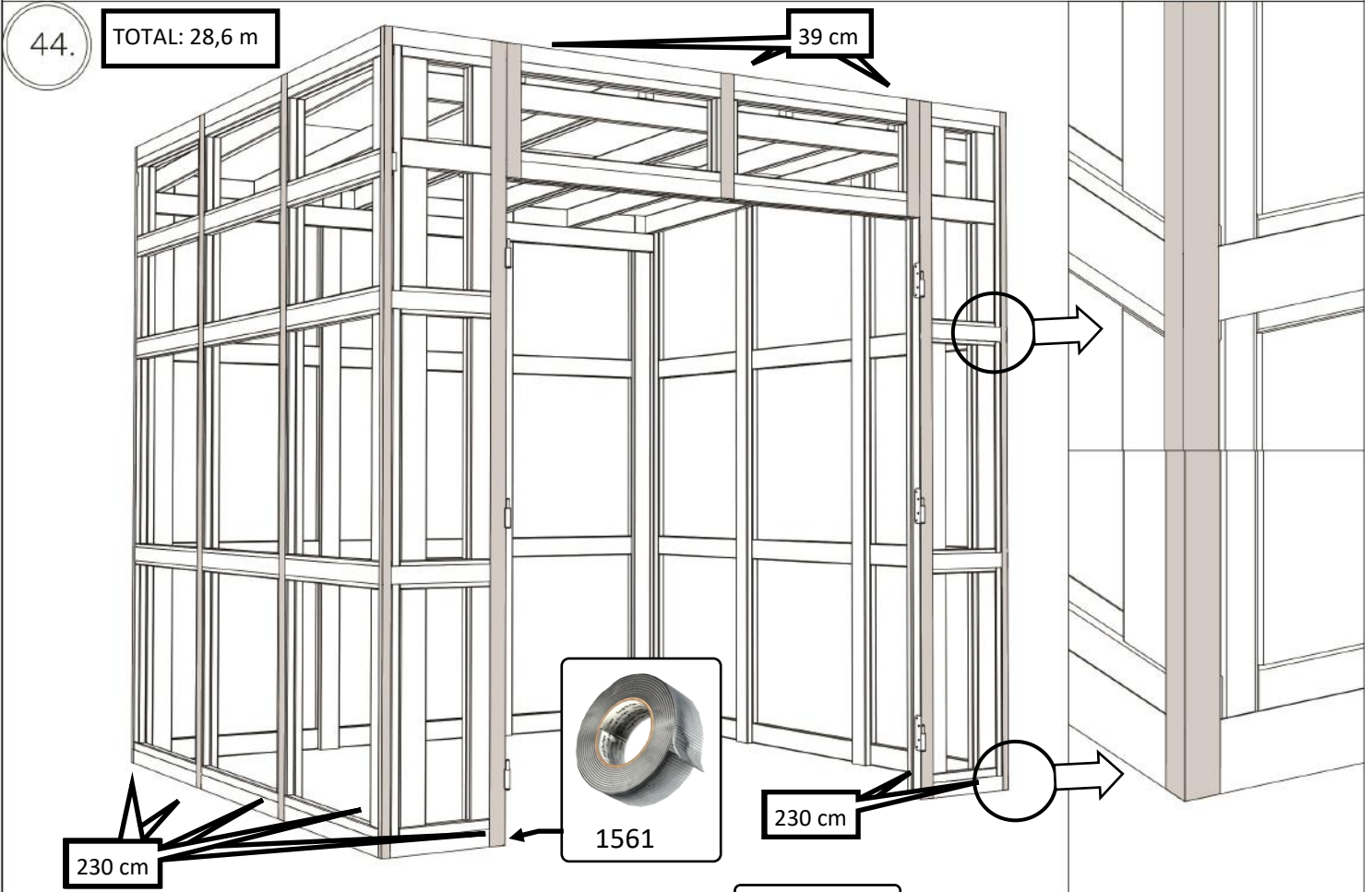

WC201161



3 Hours

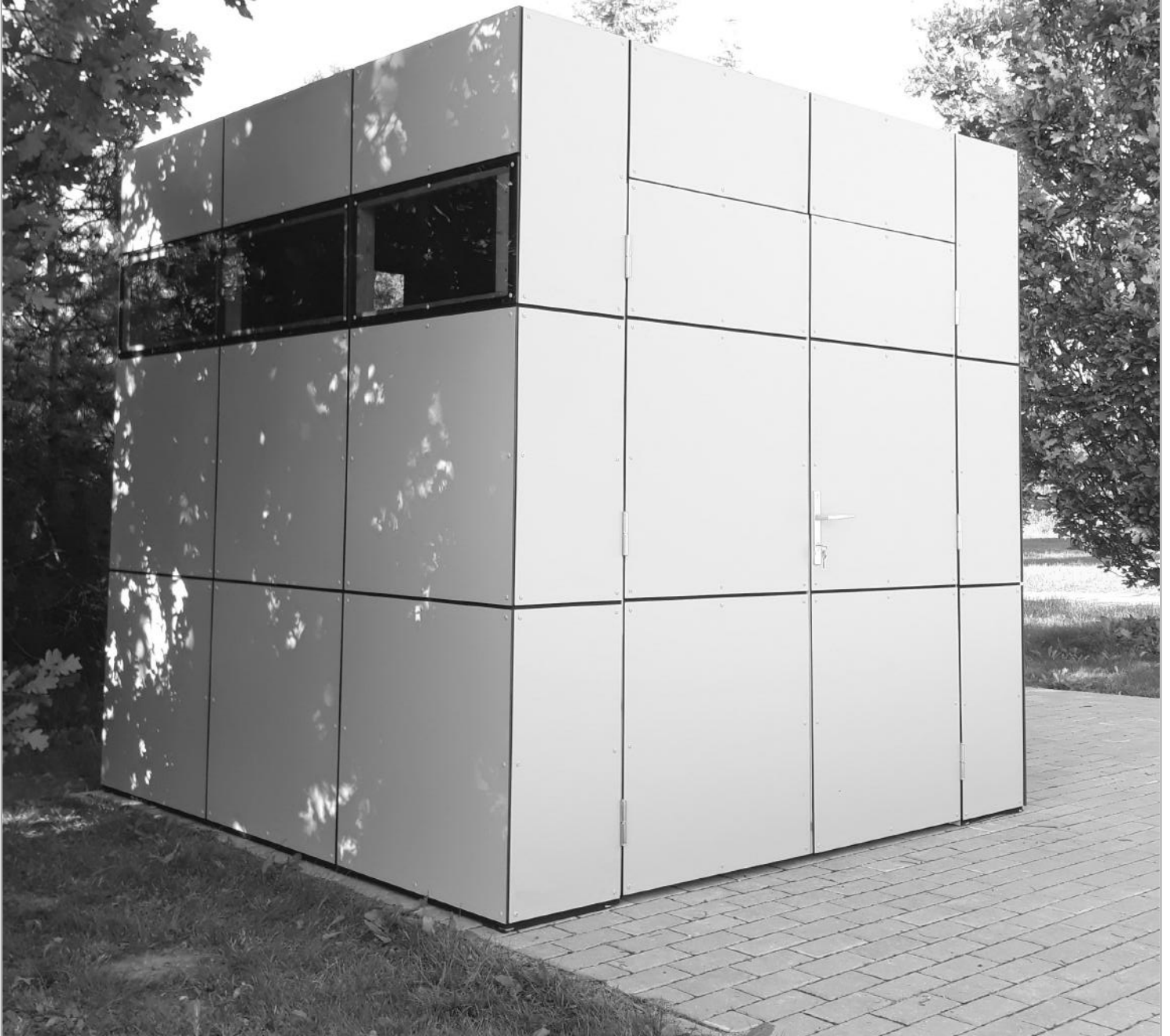

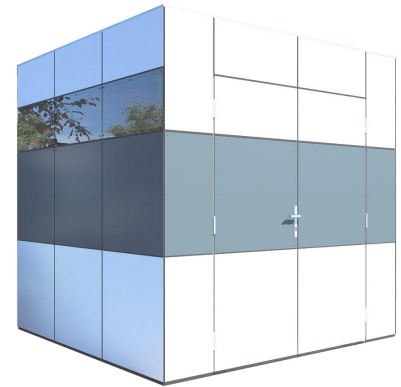
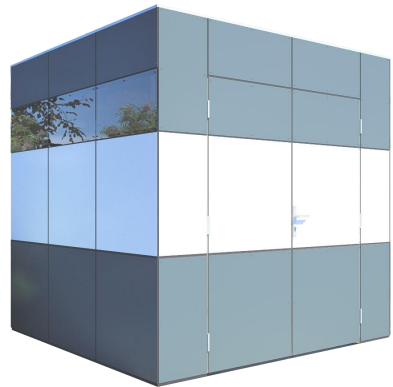
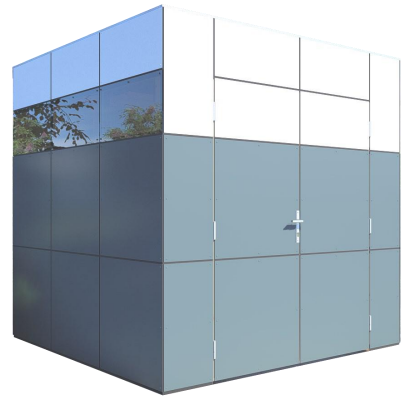
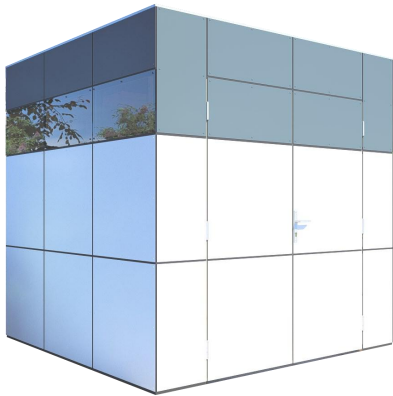
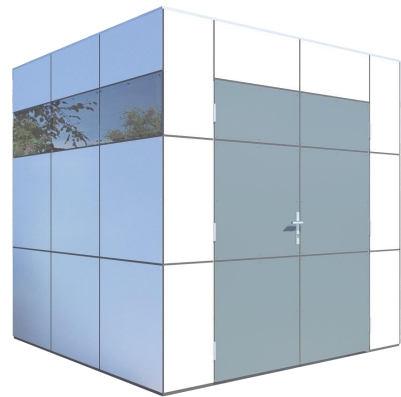
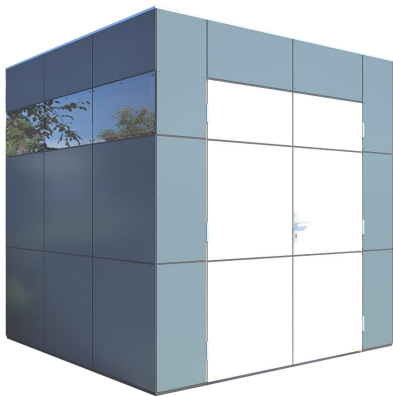
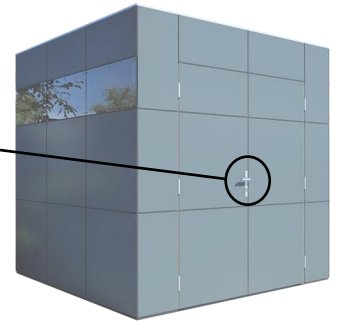
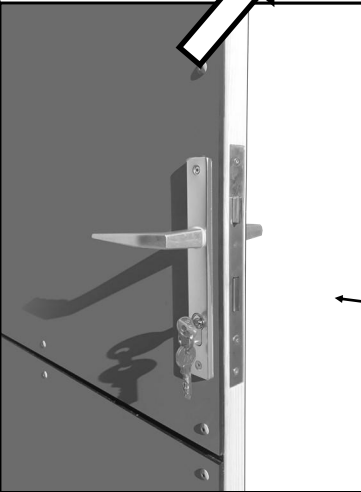
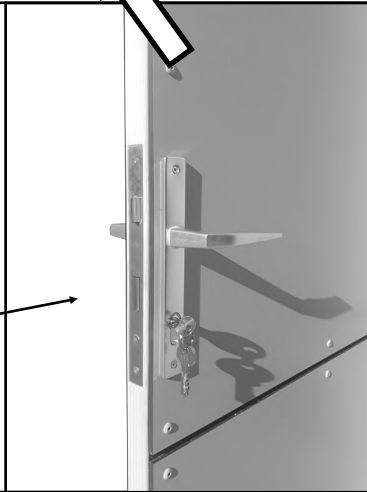
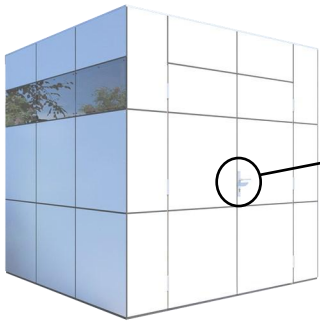
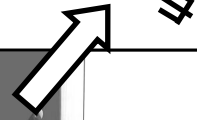
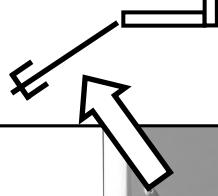

WC201161

Create your own design! Erstellen Sie Ihr eigenes Design! Créez votre propre design! Creëer je eigen ontwerp!

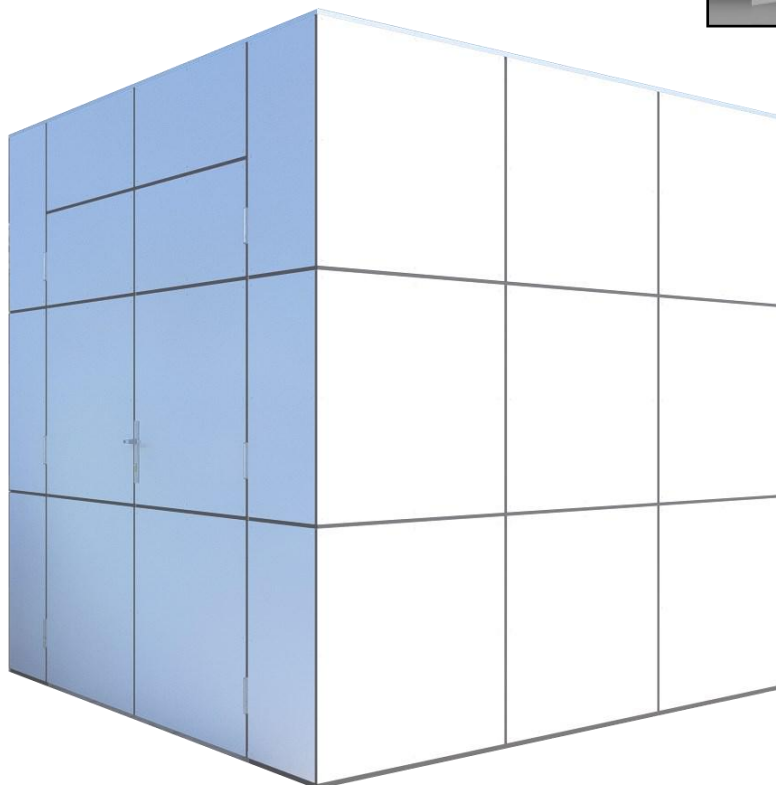
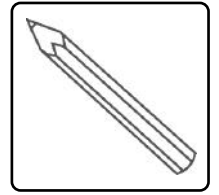
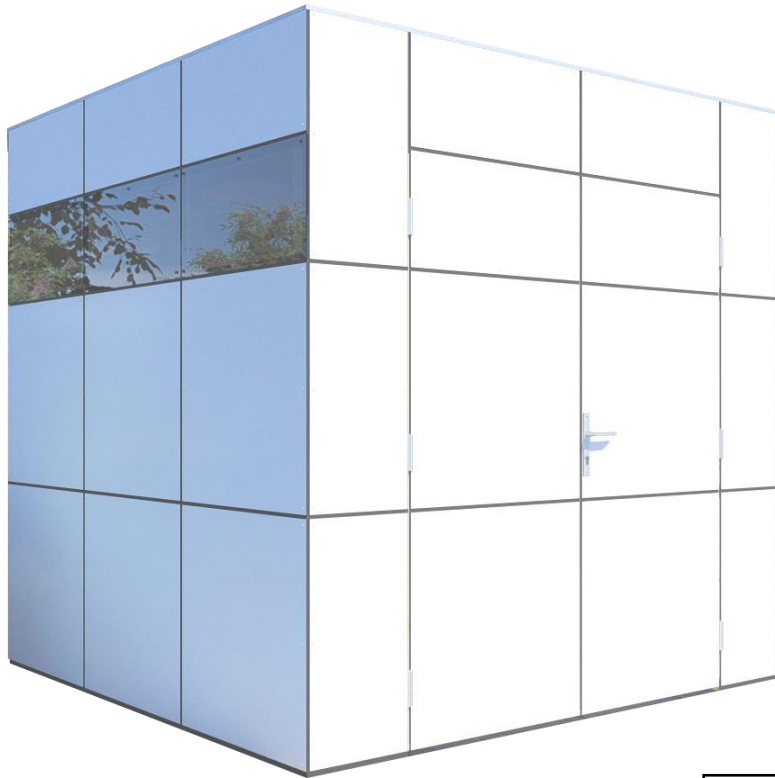

WC201161

45.

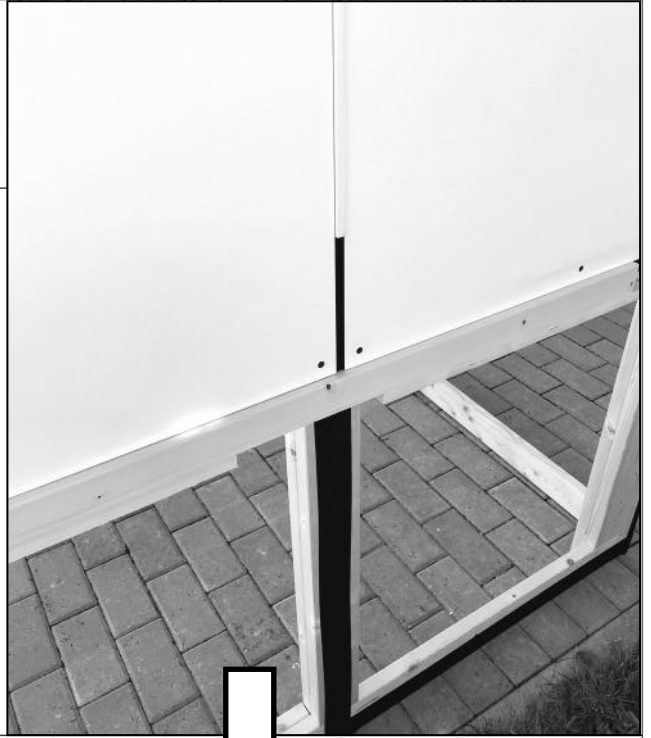
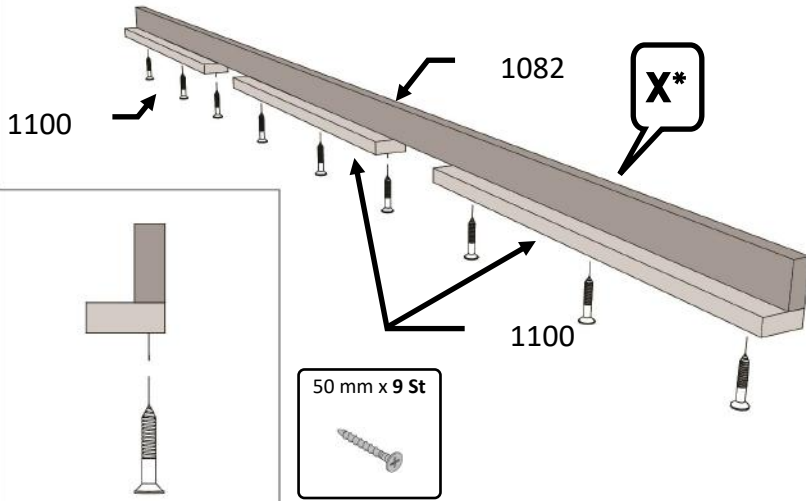
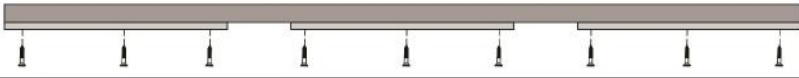

46.

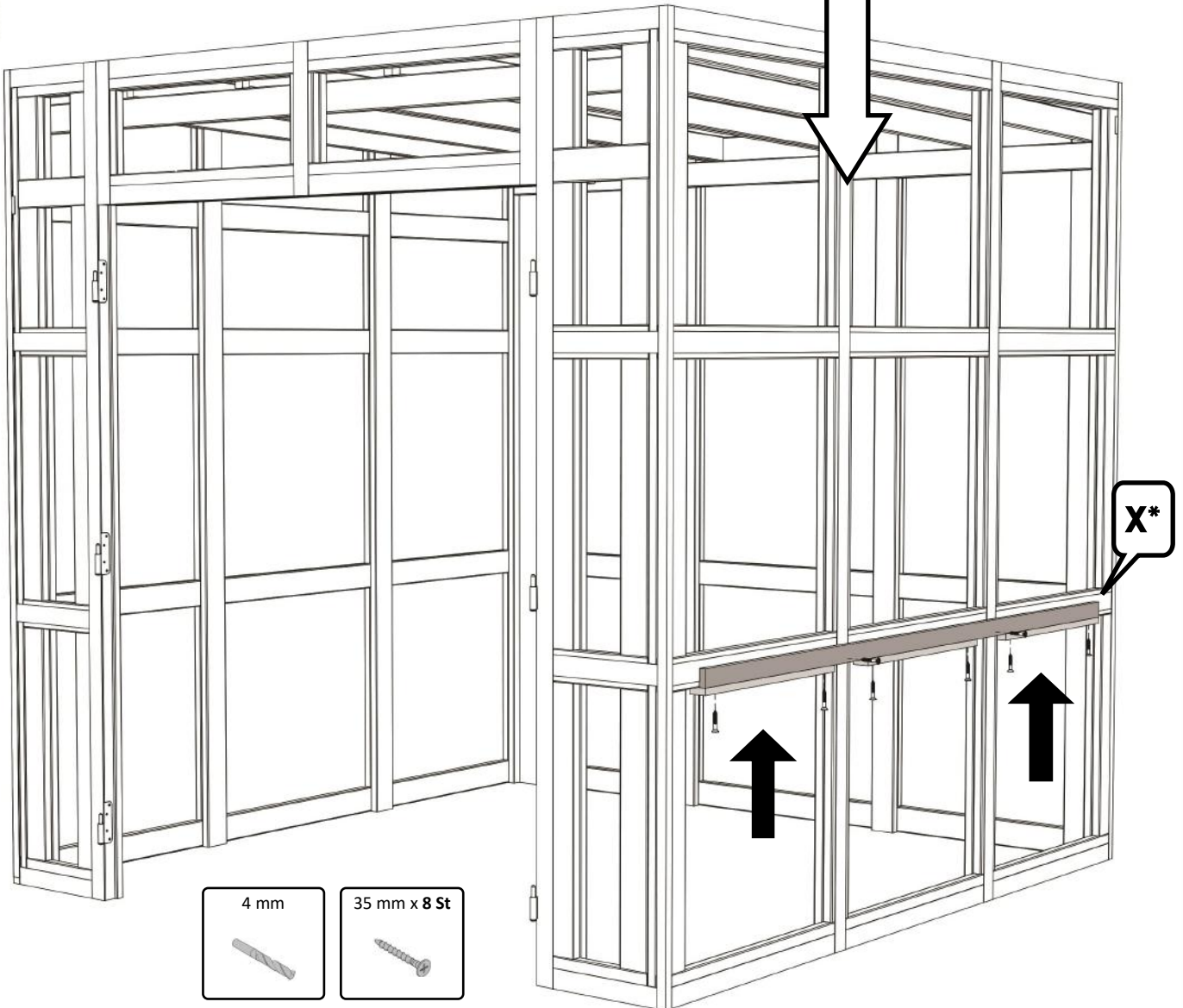

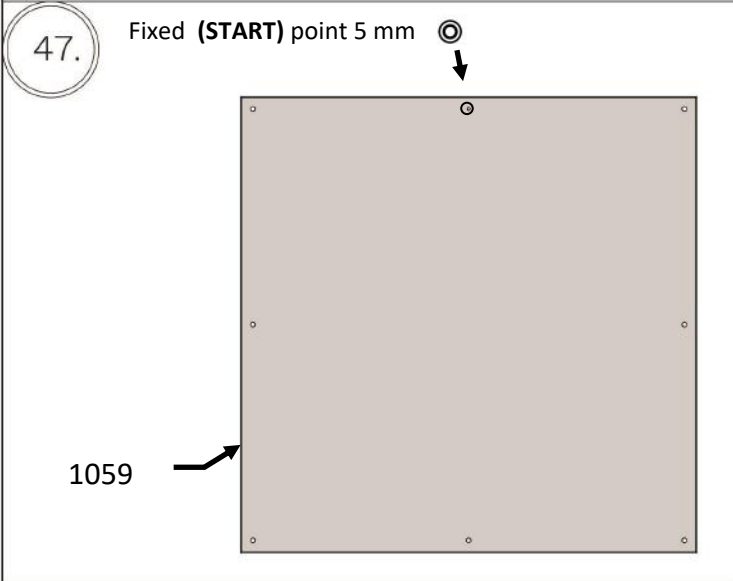

WC201161





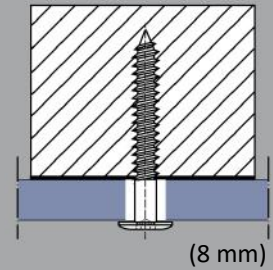
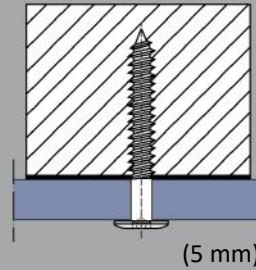

NL Fixatiepunt
FR Point fixe
DE Festpunkt
UK Fixed point



Dilatatiepunt
Point coulissant
Gleitpunkt
Sliding point



UK  = fixed point in panel centre
 = sliding point
Screws must always be centered in the holes and must not be over tightened.

FR  = point fixe au centre du panneau
 = point coulissant
Les vis doivent être impérativement centrées dans les trous et ne pas être serrées excessivement.

NL  = fixatiepunt in het midden van het paneel
 = dilatatiepunt
De schroeven moeten altijd in de boorgaten gecentreerd worden en mogen niet te vast worden aangedraaid.

DE  = Festpunkt in der Plattenmitte
 = Gleitpunkt
Schrauben müssen immer mittig im Loch platziert werden und dürfen nicht überzogen werden.

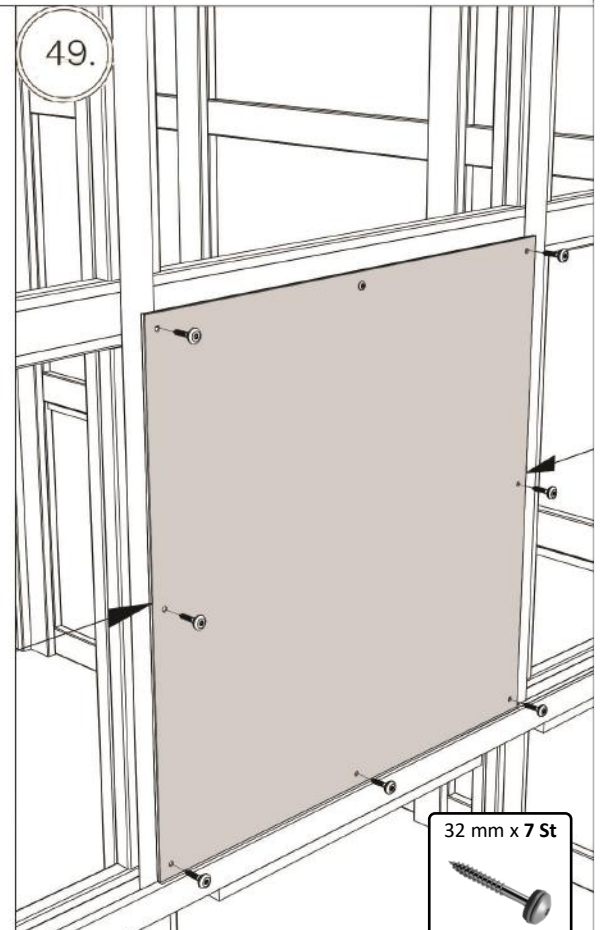
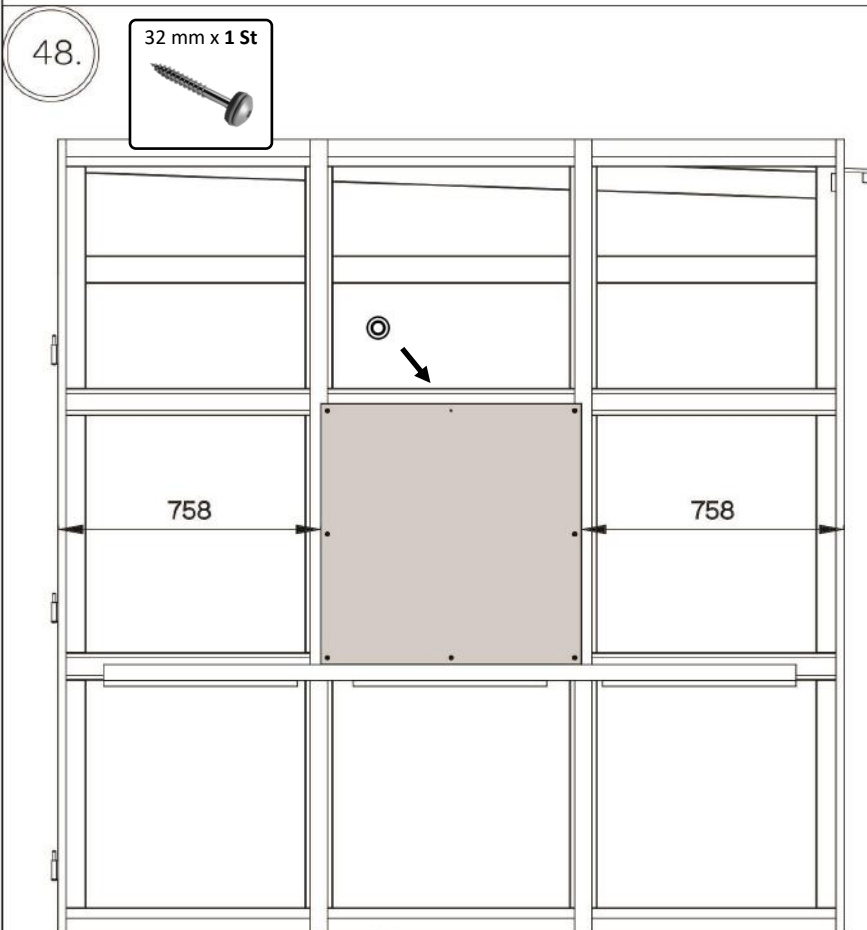

WC201161

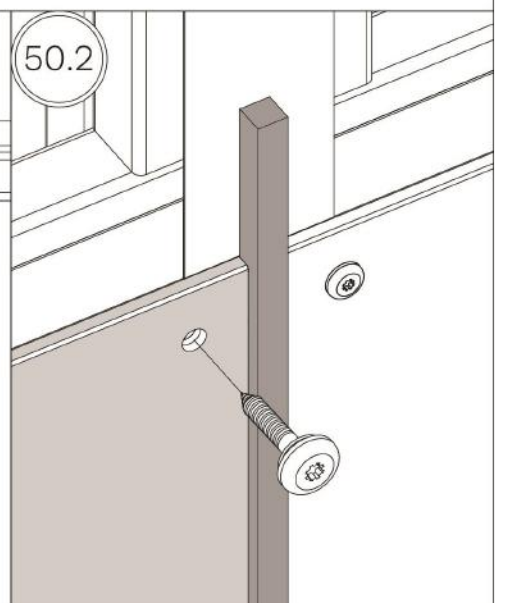
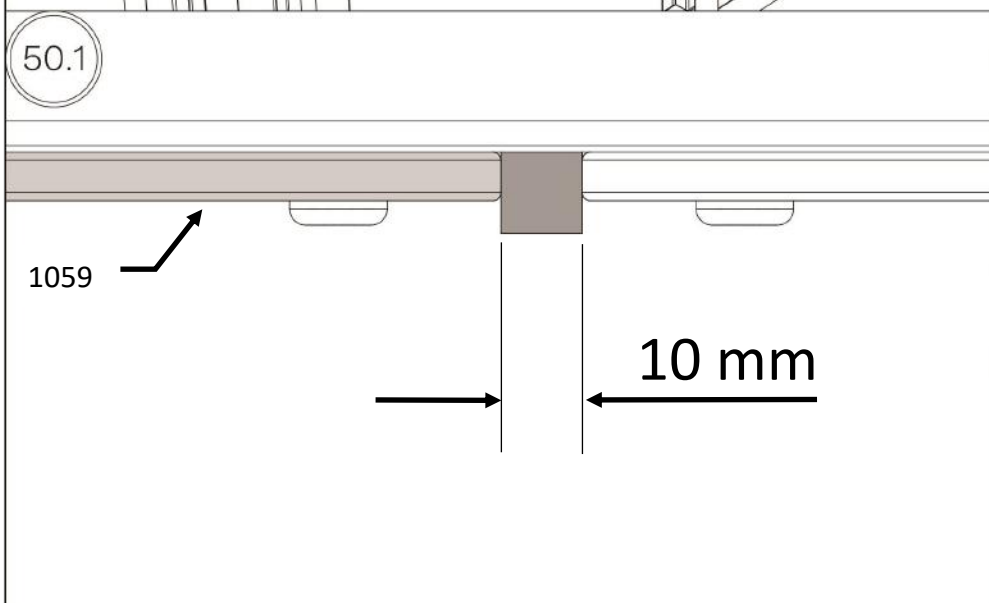
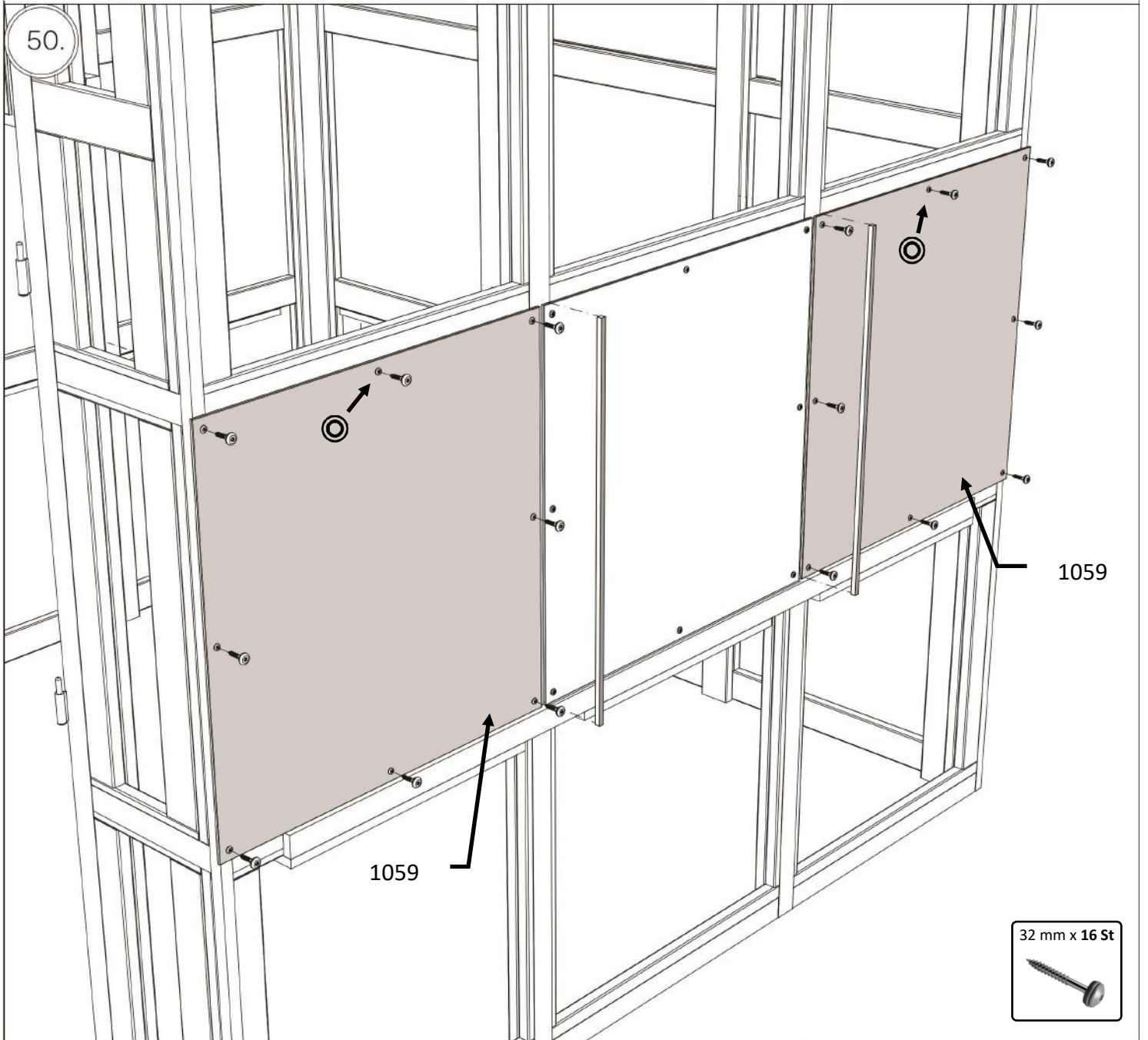

WC201161

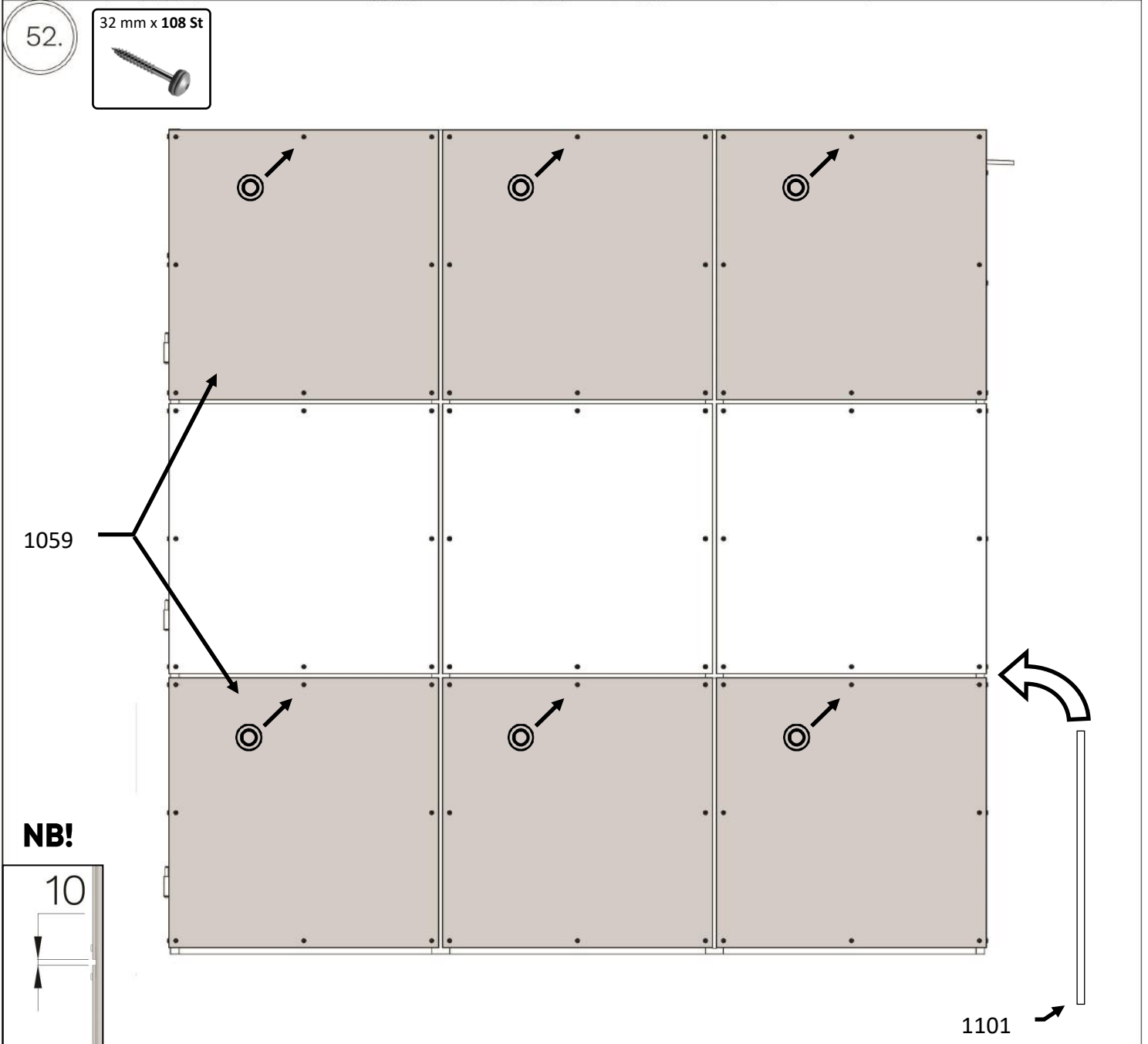
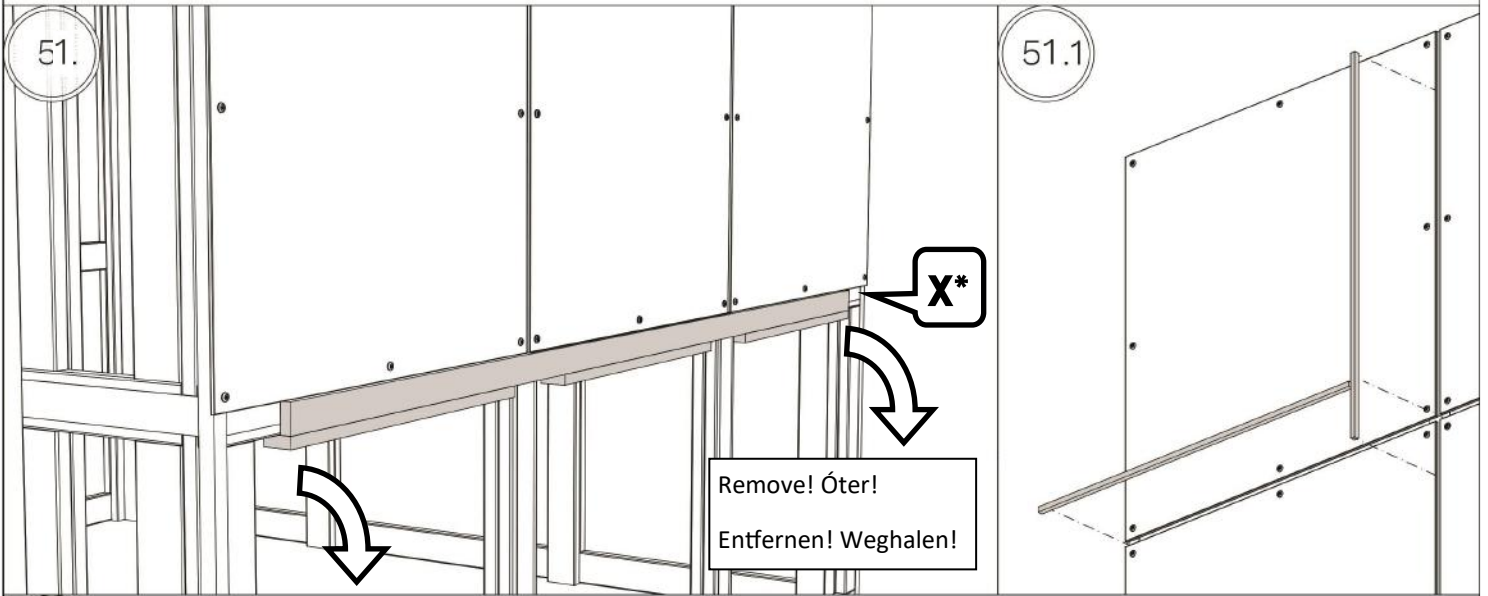

WC201161

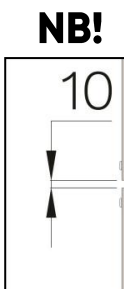
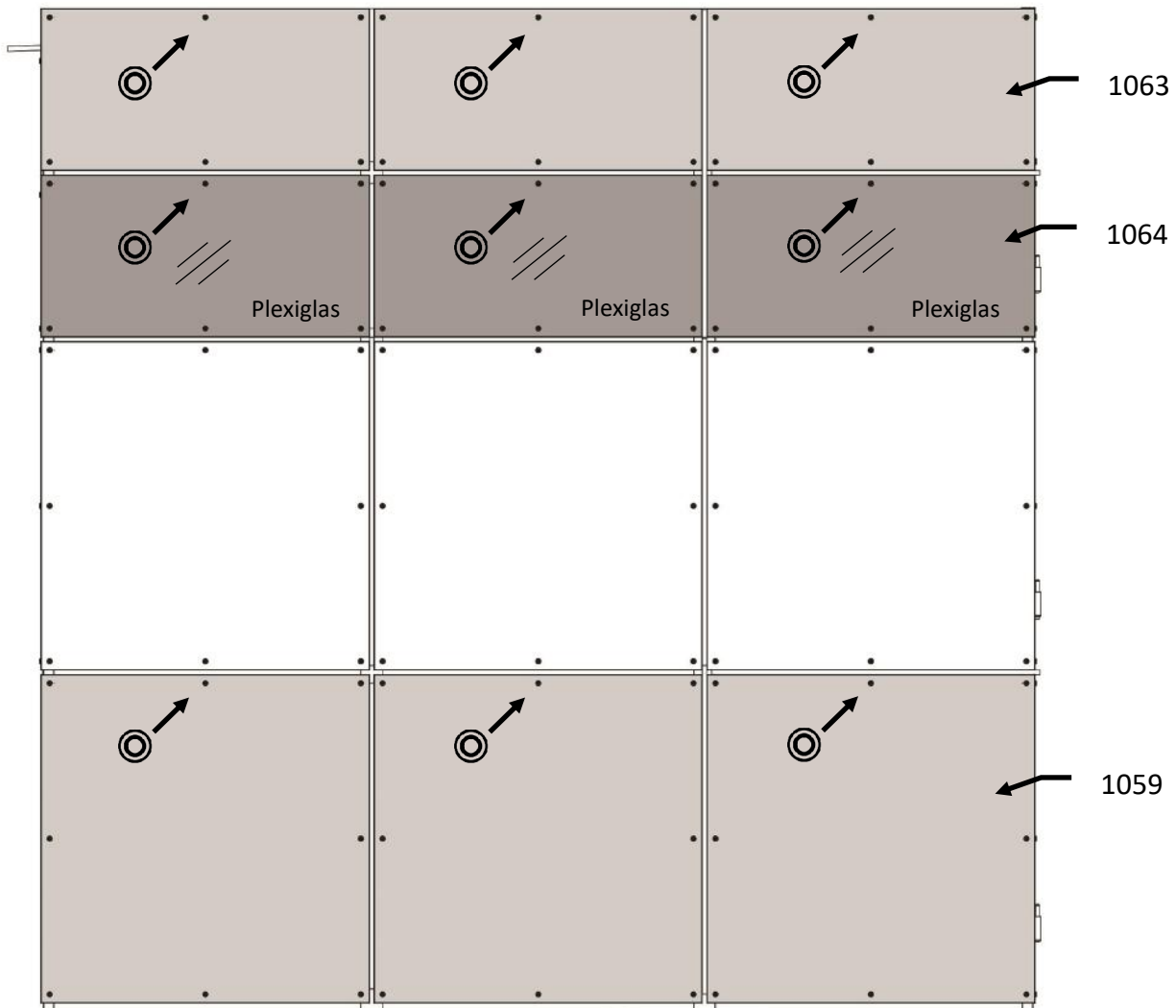
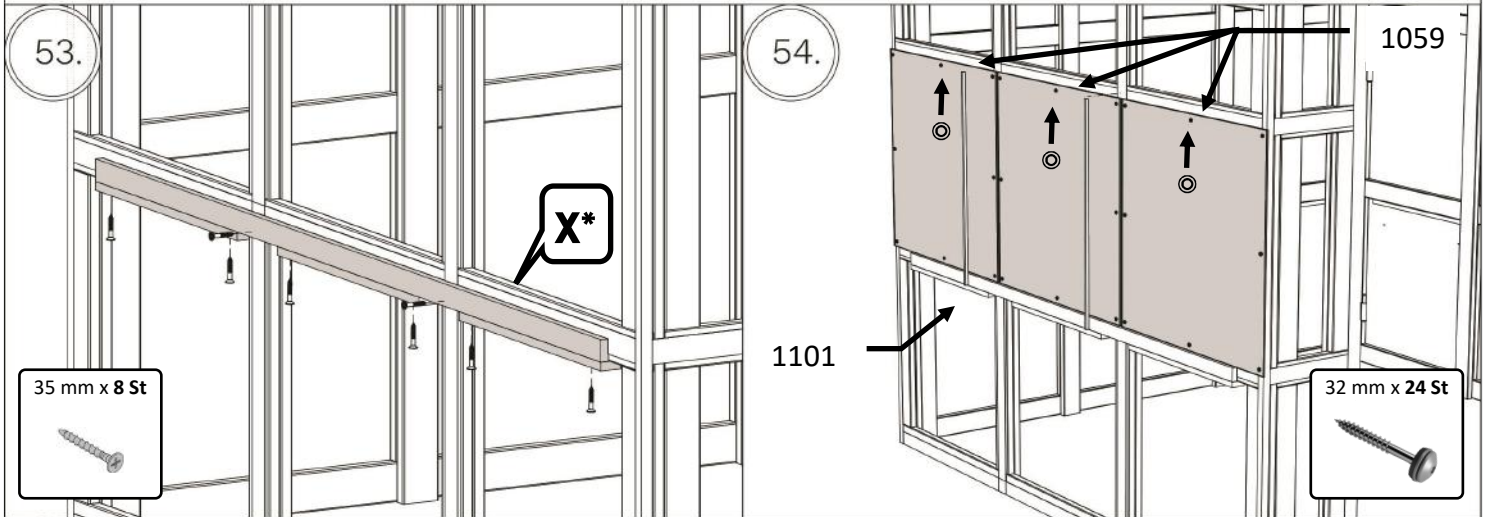

WC201161

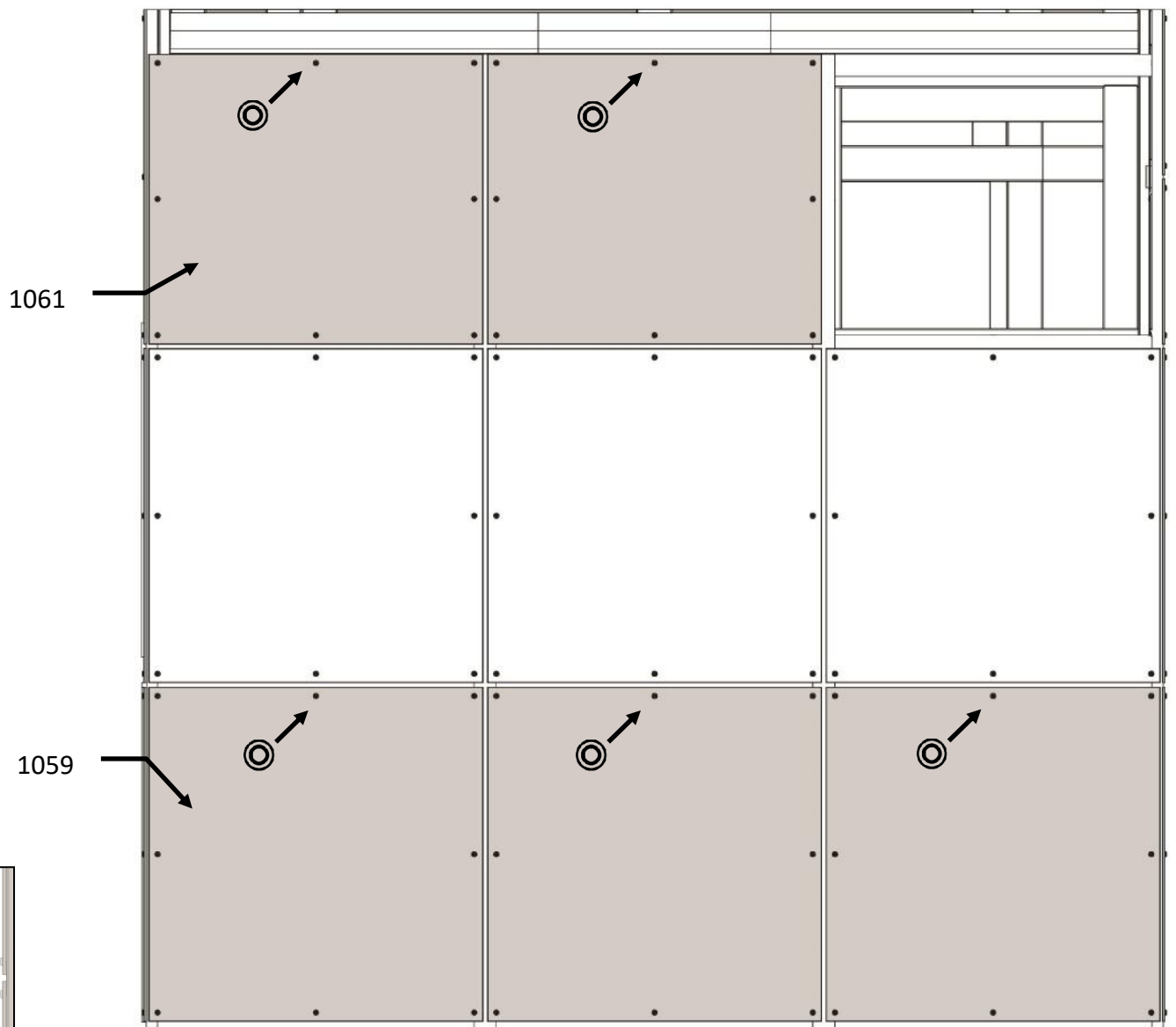
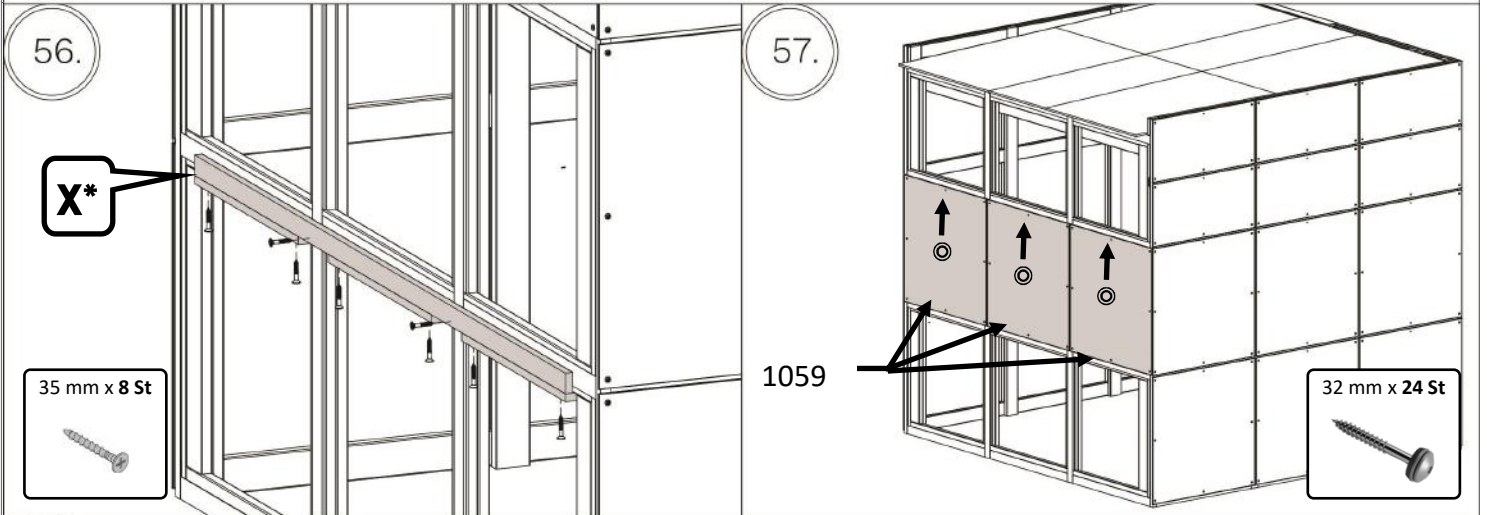

WC201161

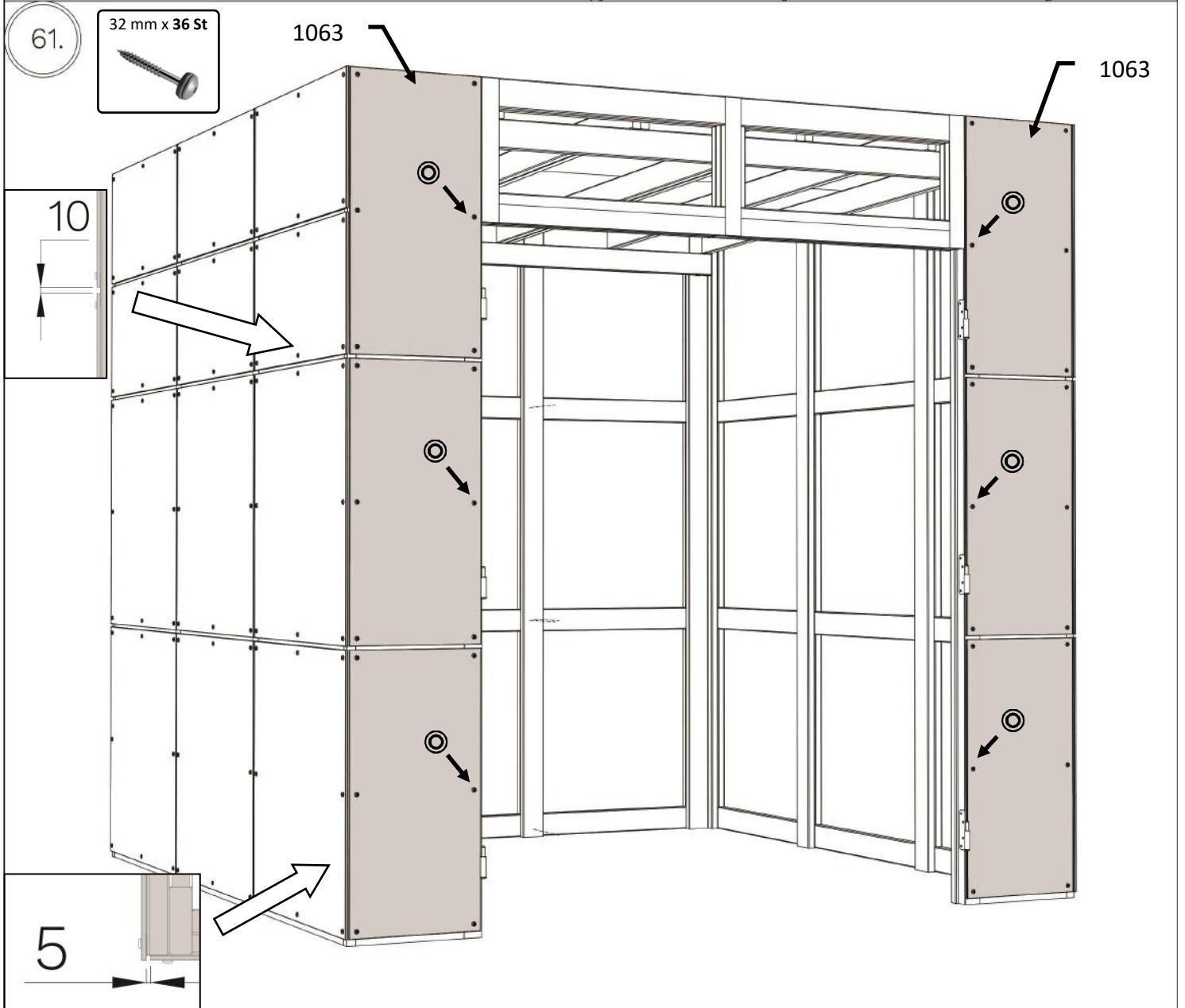
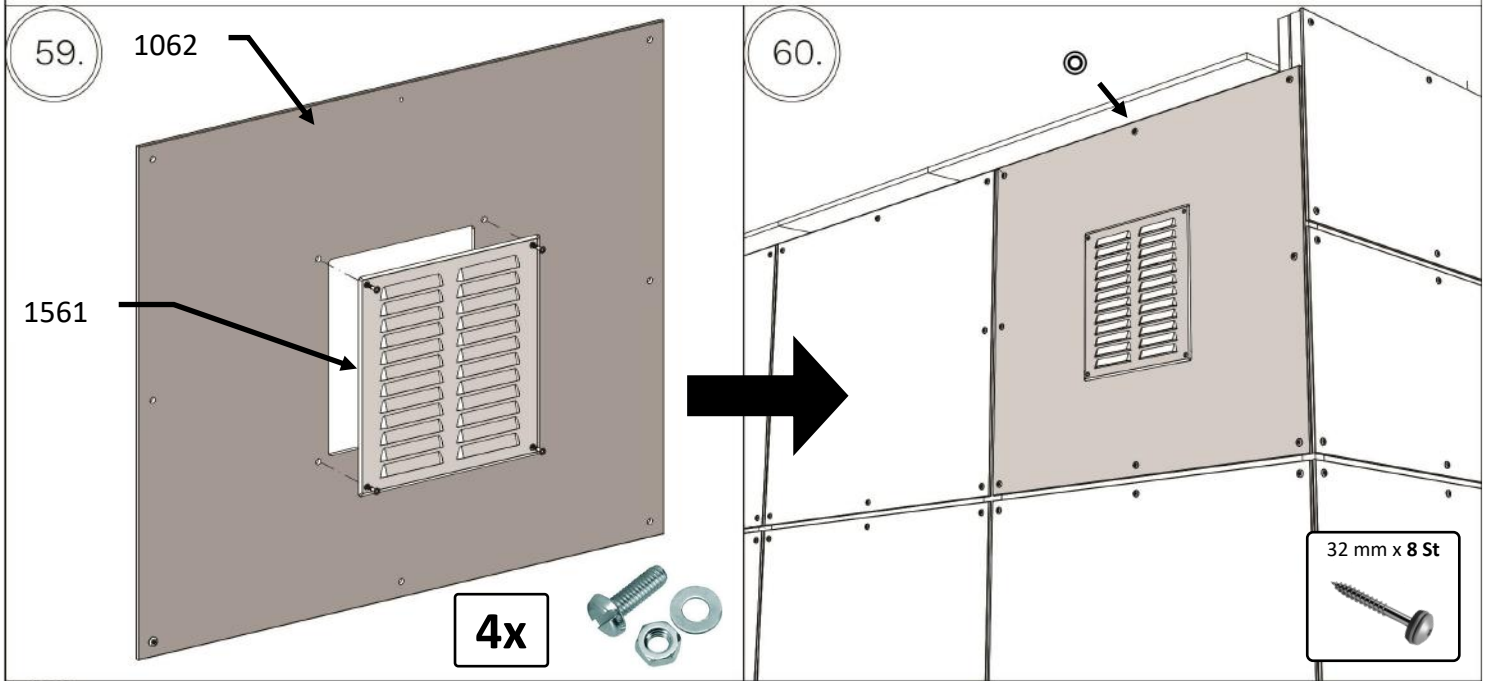

WC201161

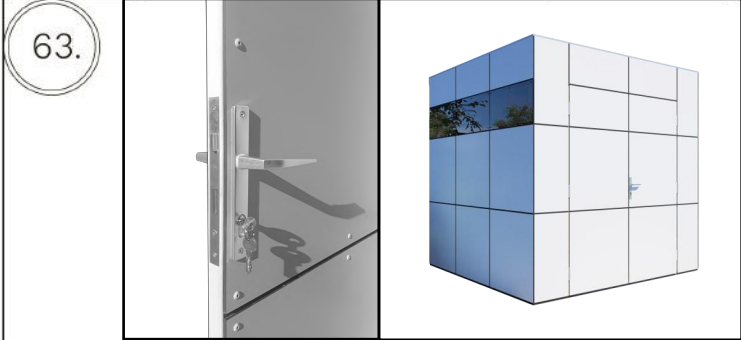
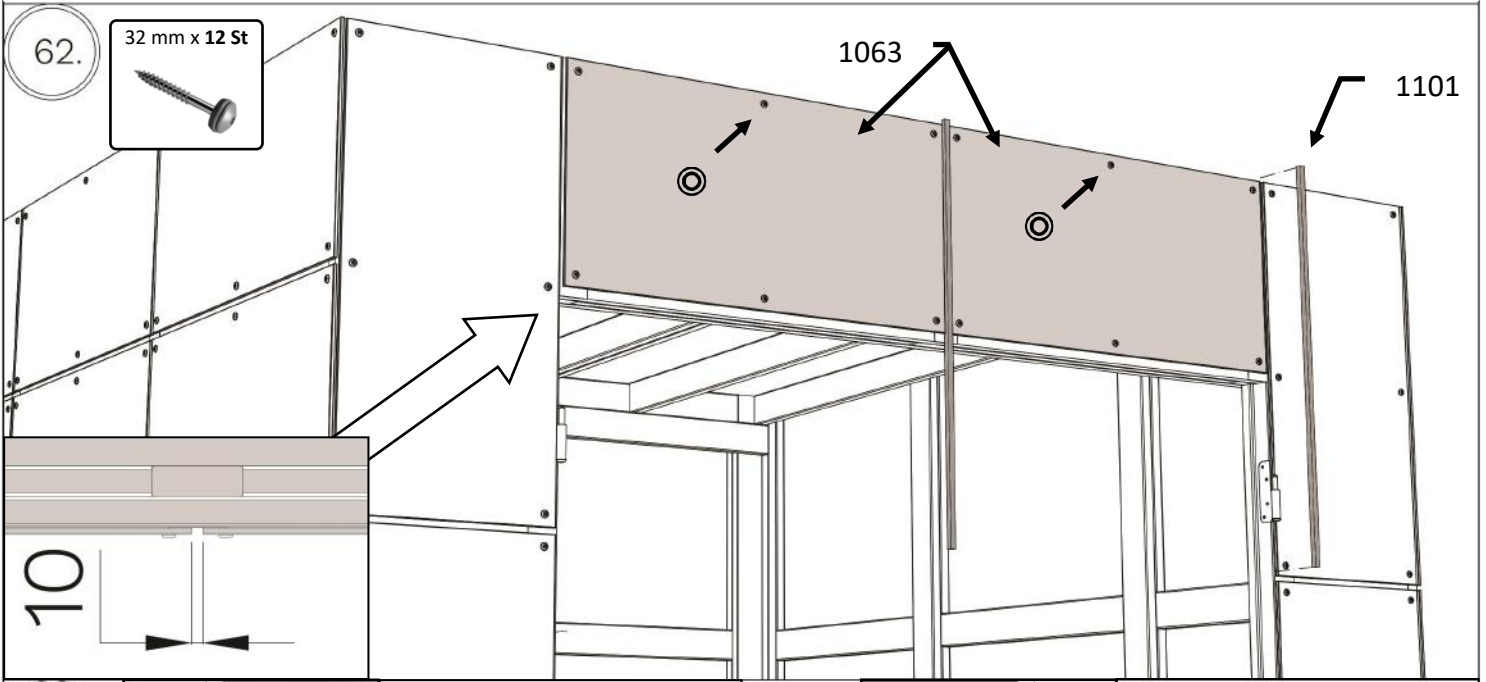

Silver Grey / Pure White

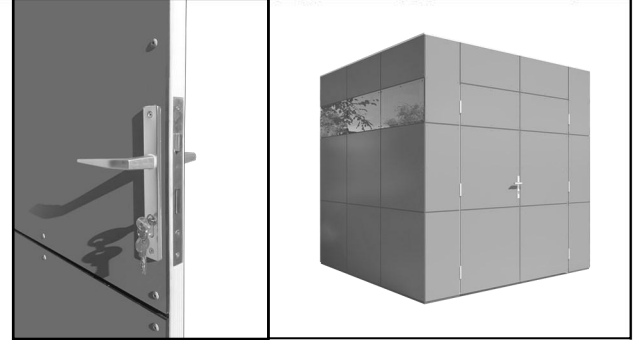

Anthracite Grey

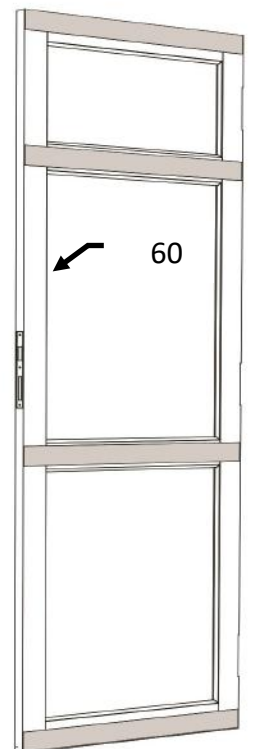
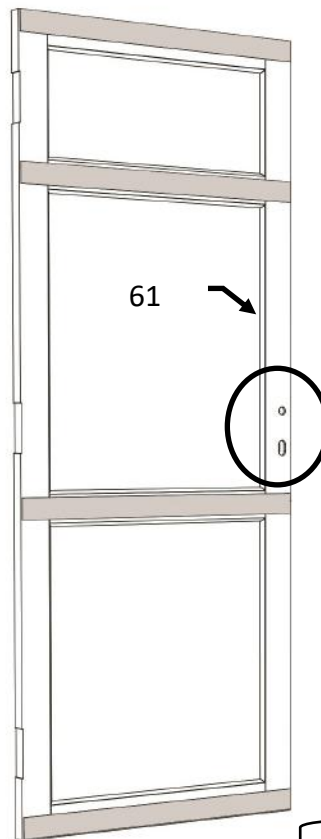
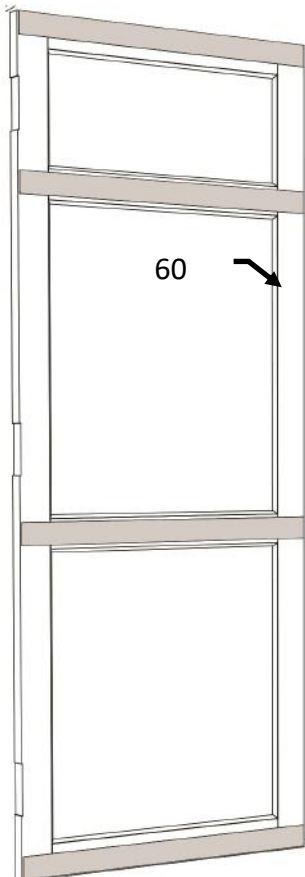

Holzschutzmittel / Wood preservative

WC201161

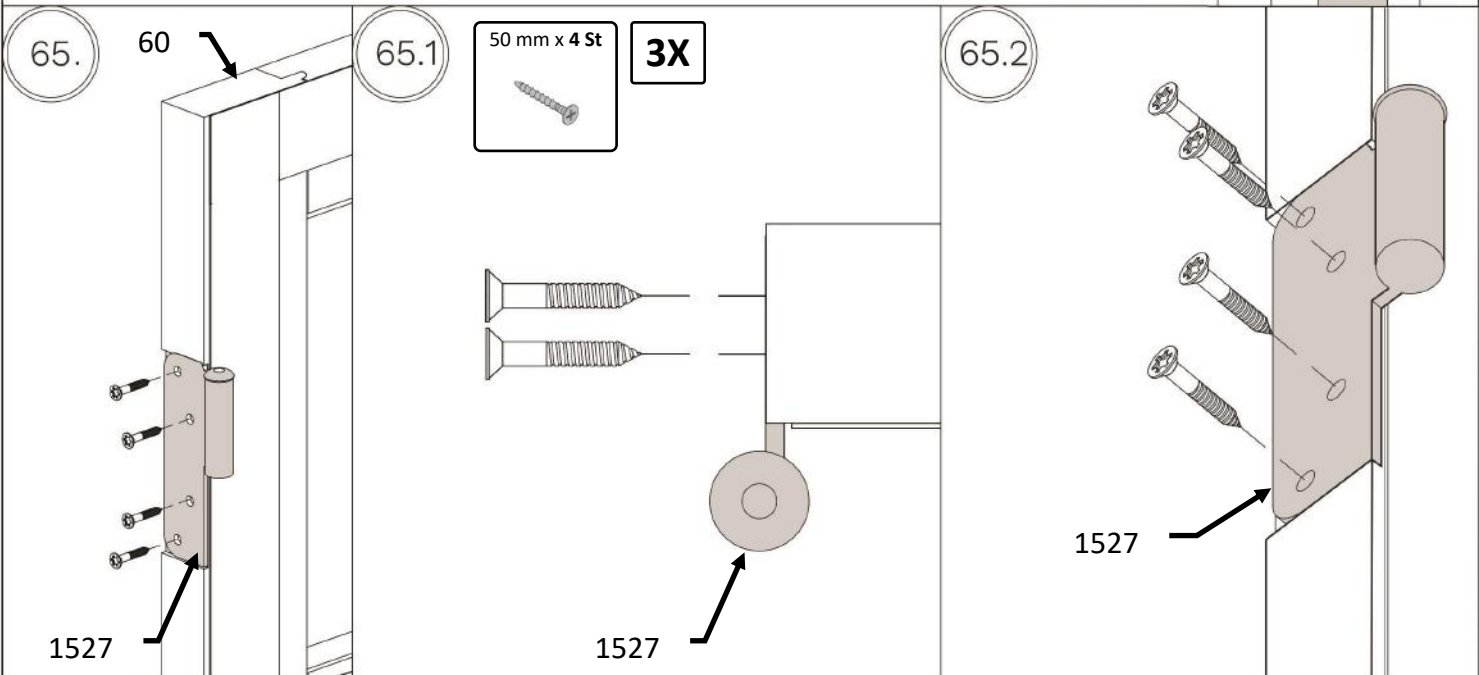
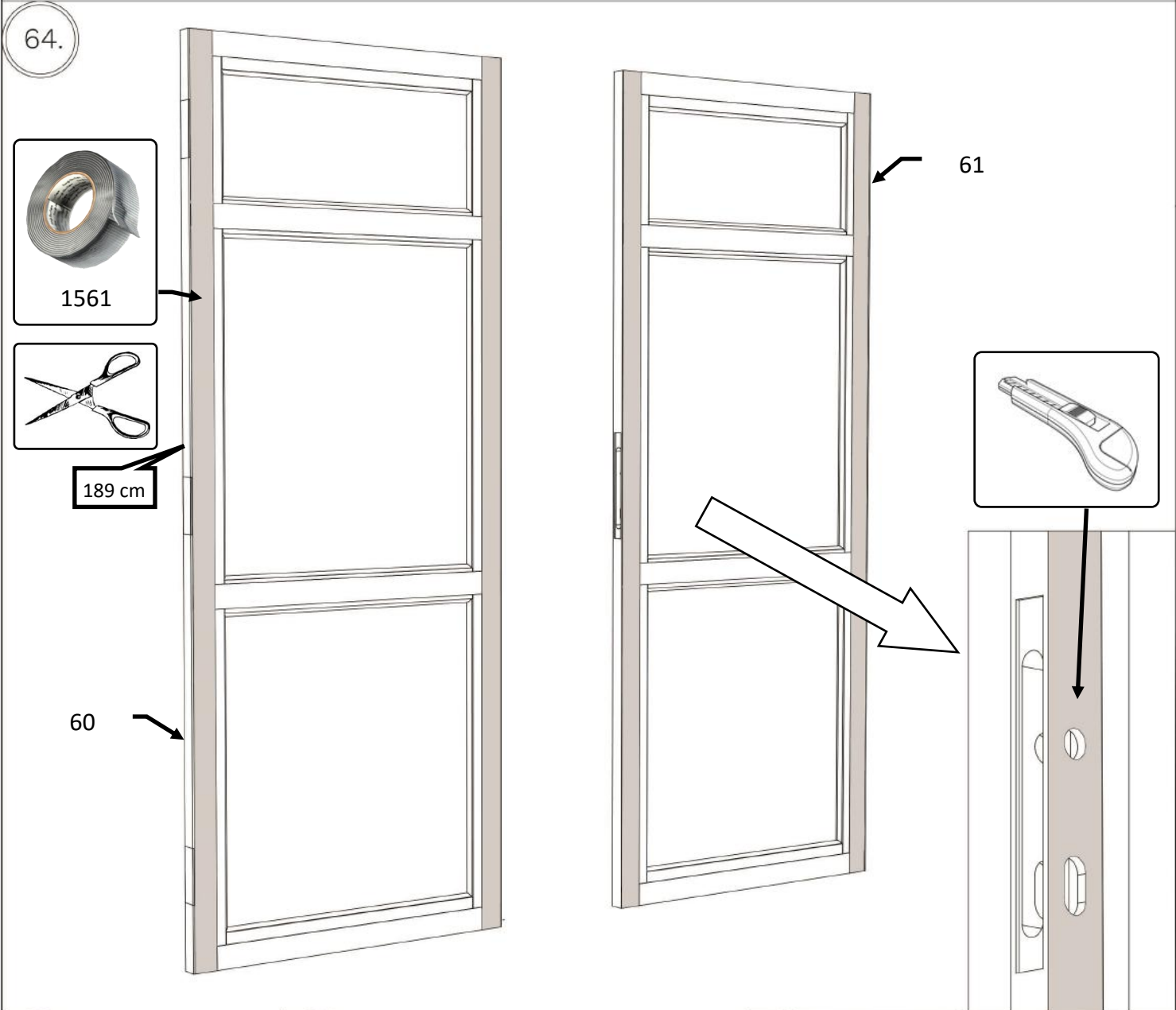

WC201161

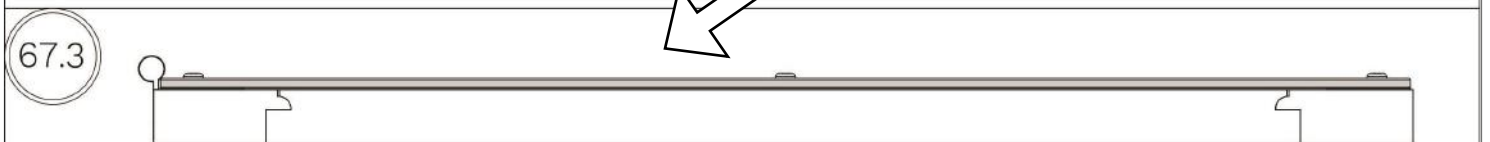
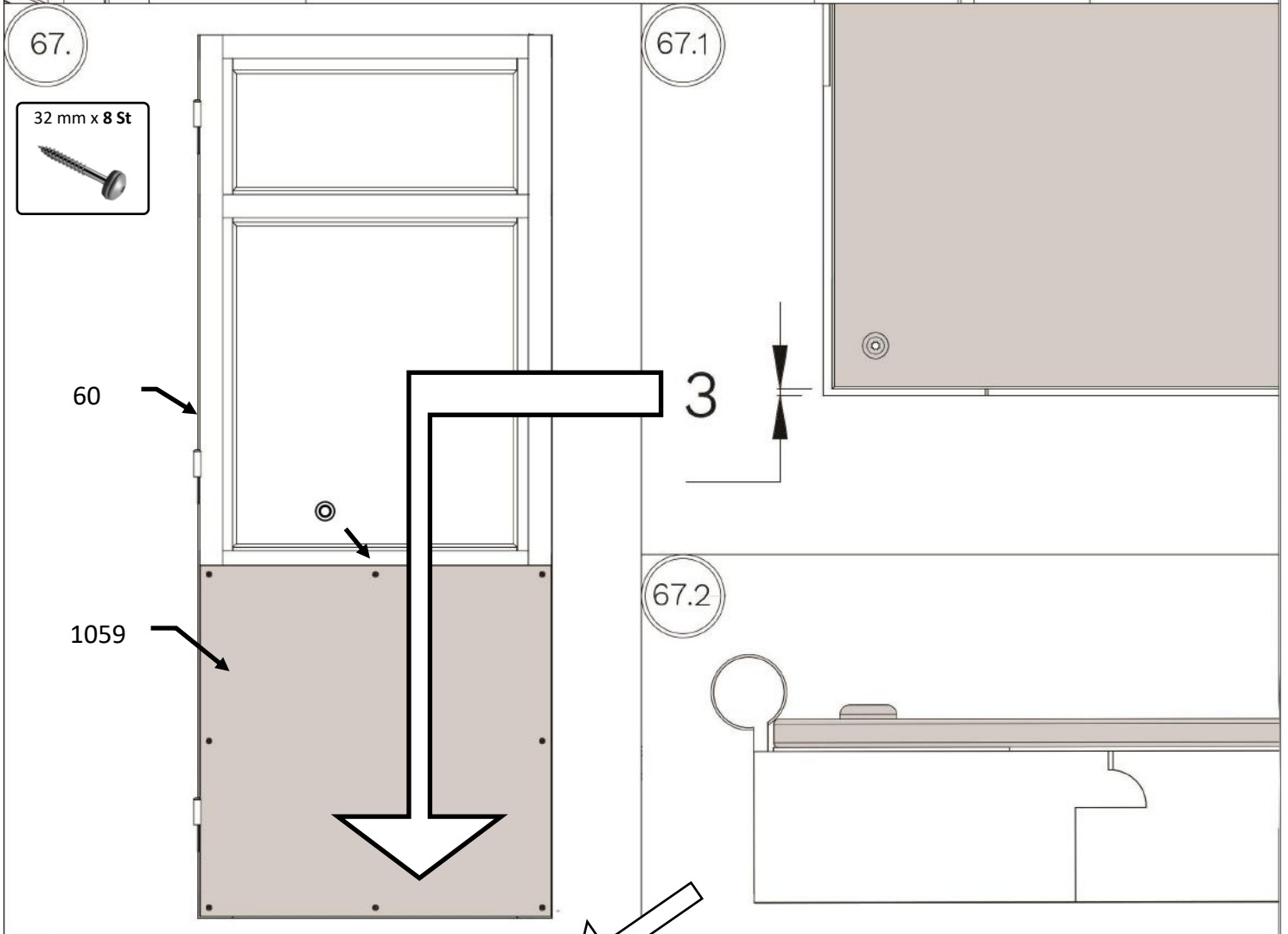
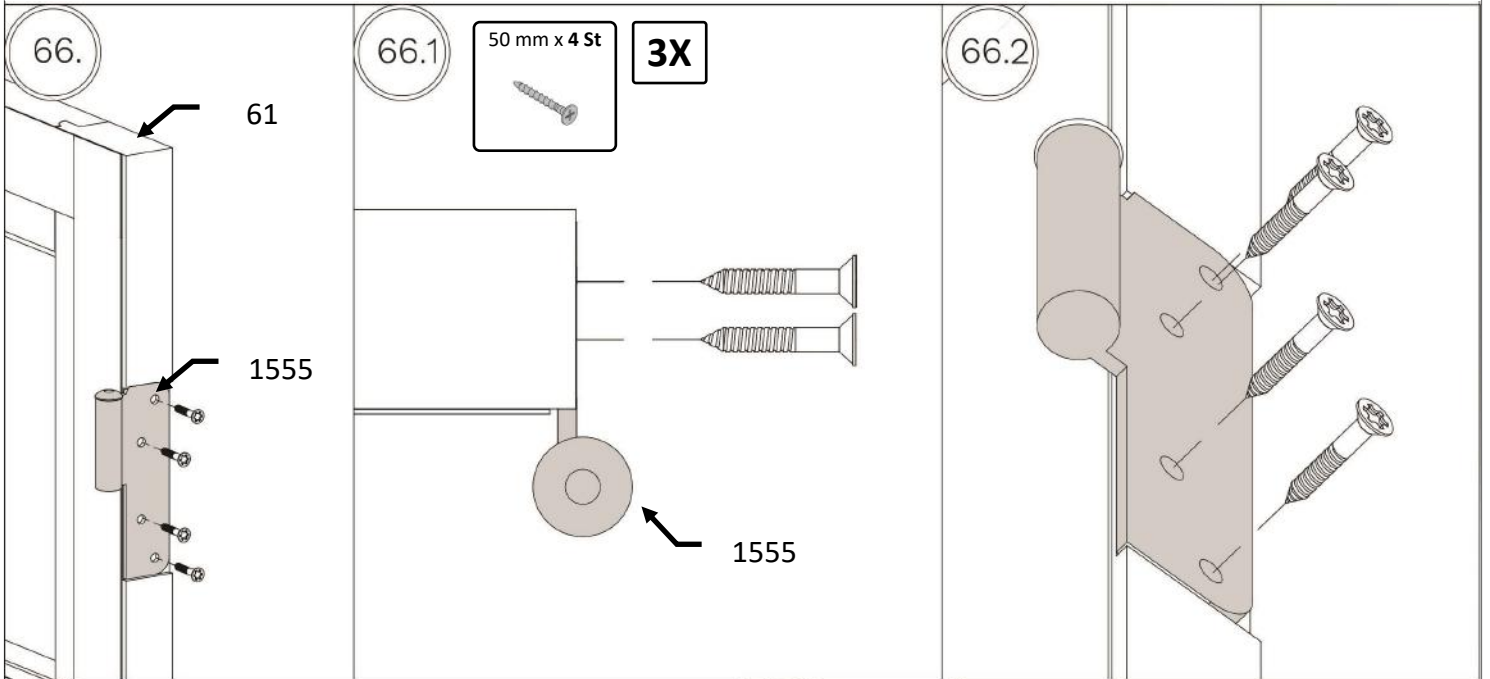

WC201161

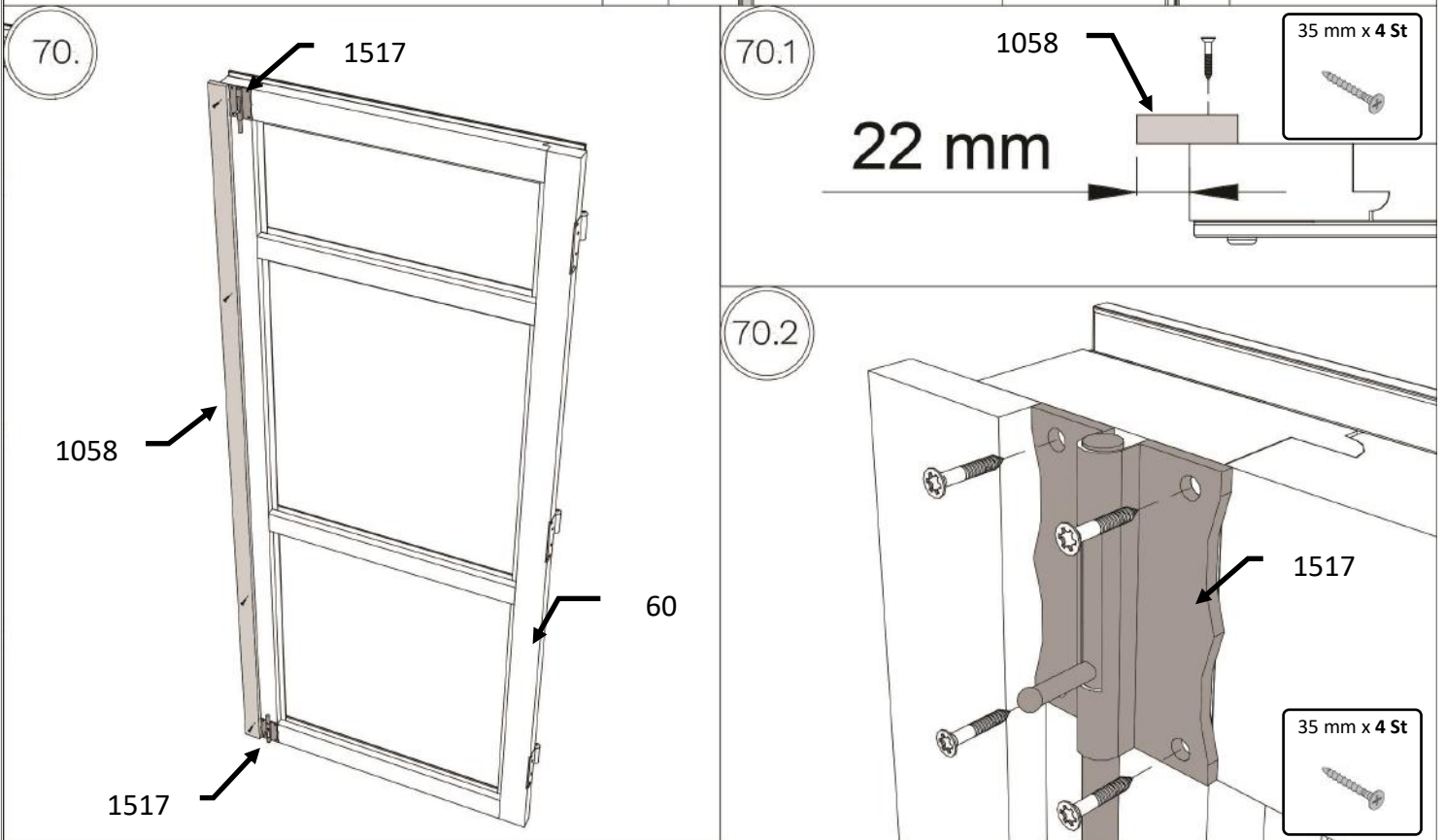
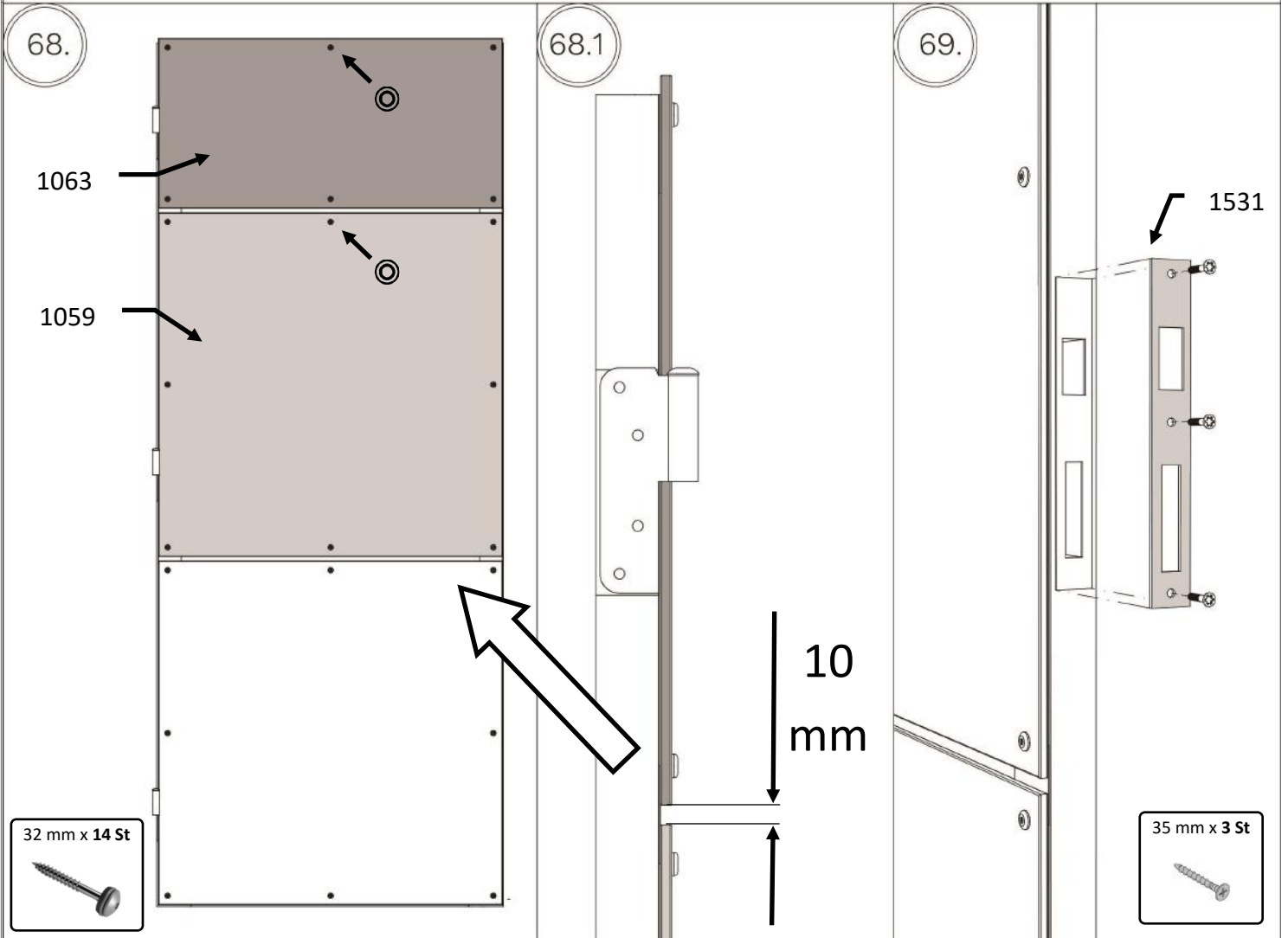

WC201161

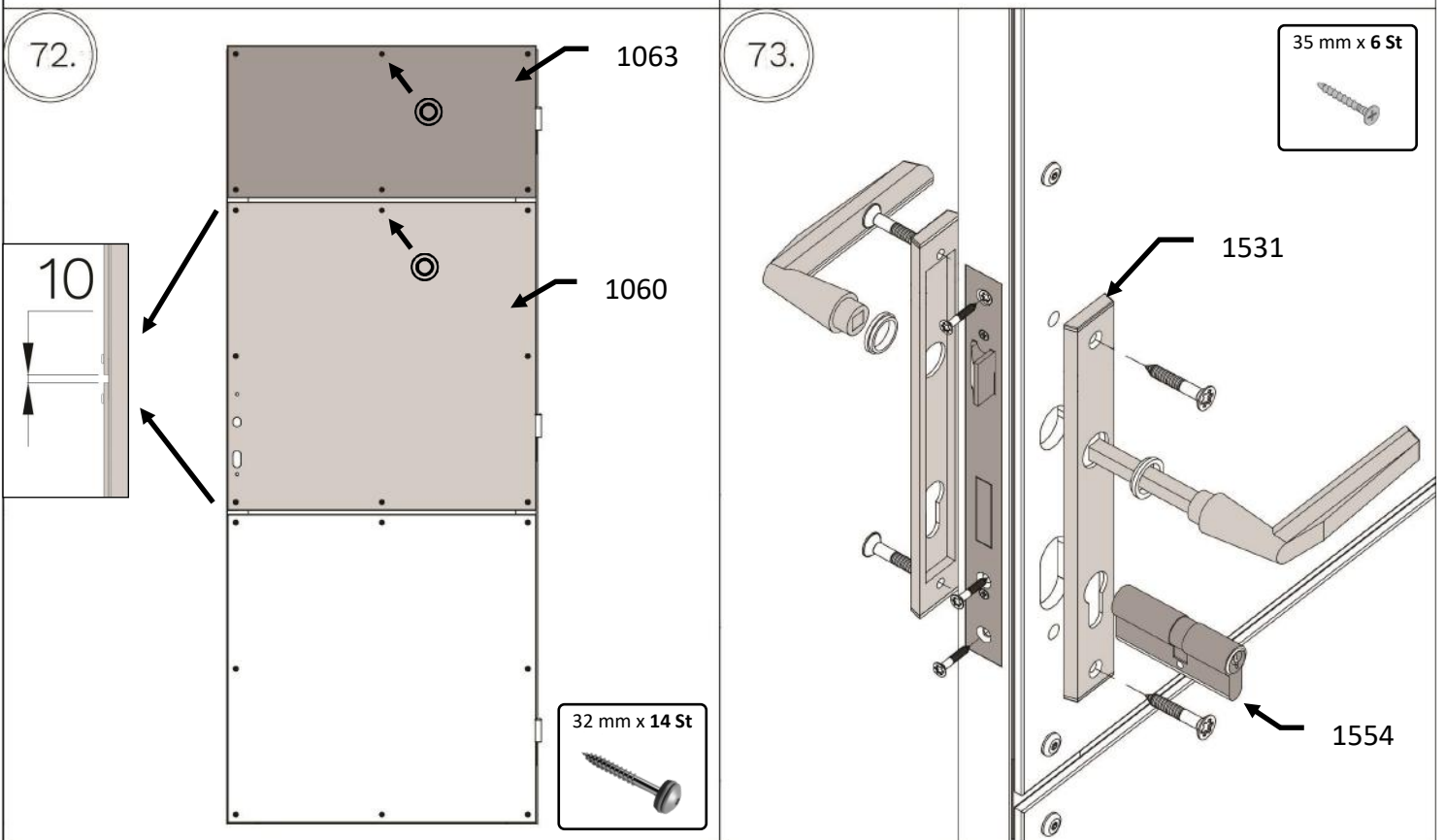
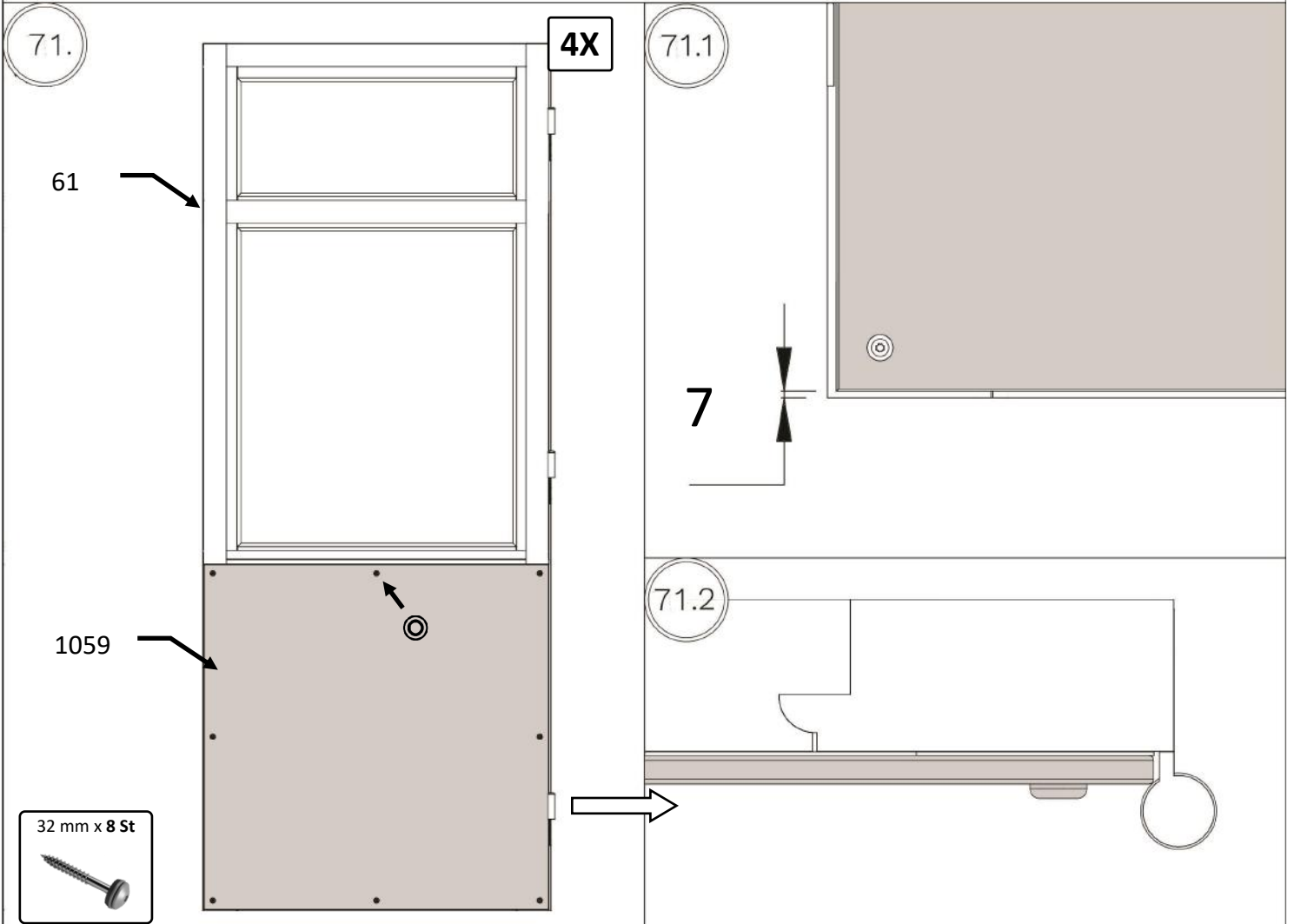

WC201161

74.

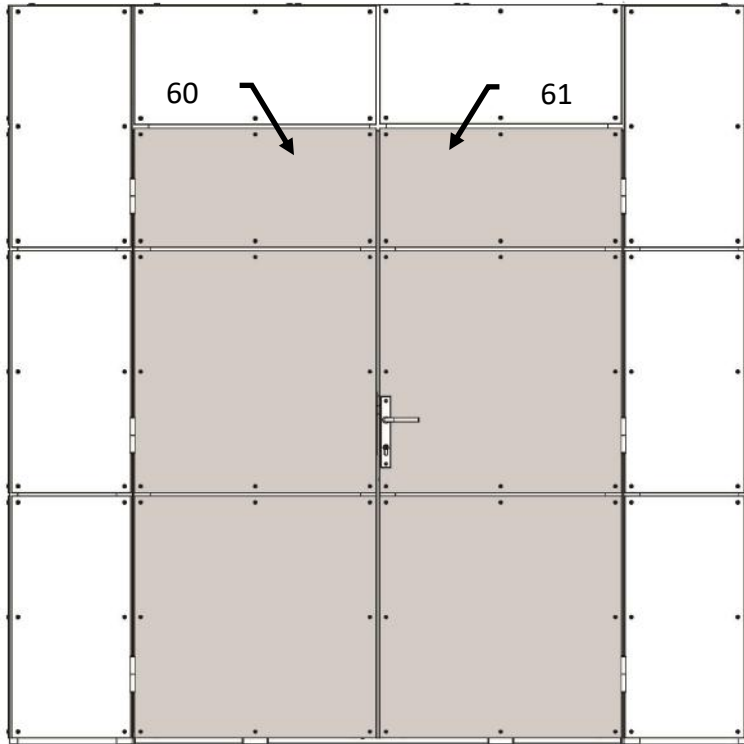

75.

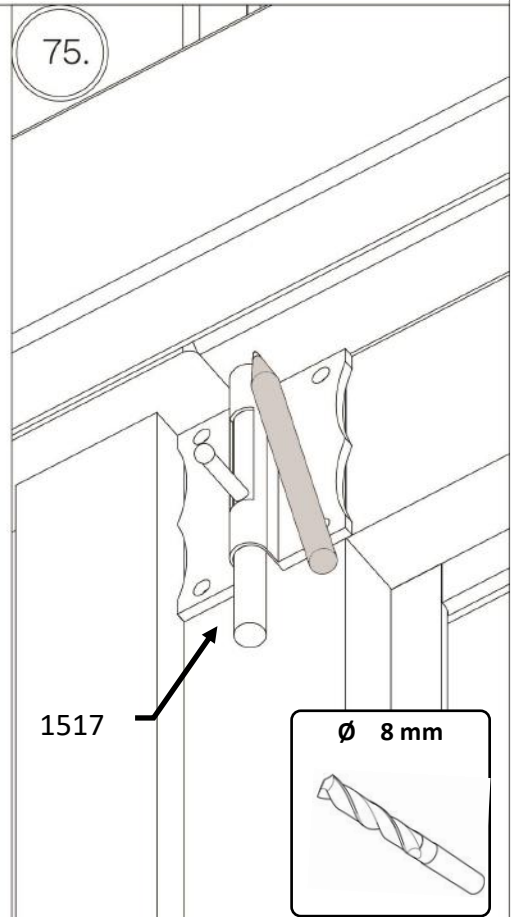

76.

35 mm x 10 St



1054

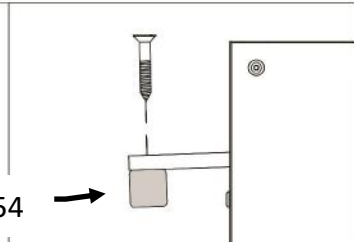

76.1

38 mm x 5 St



1570

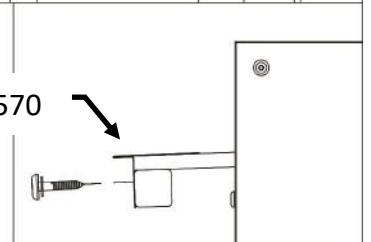

1054

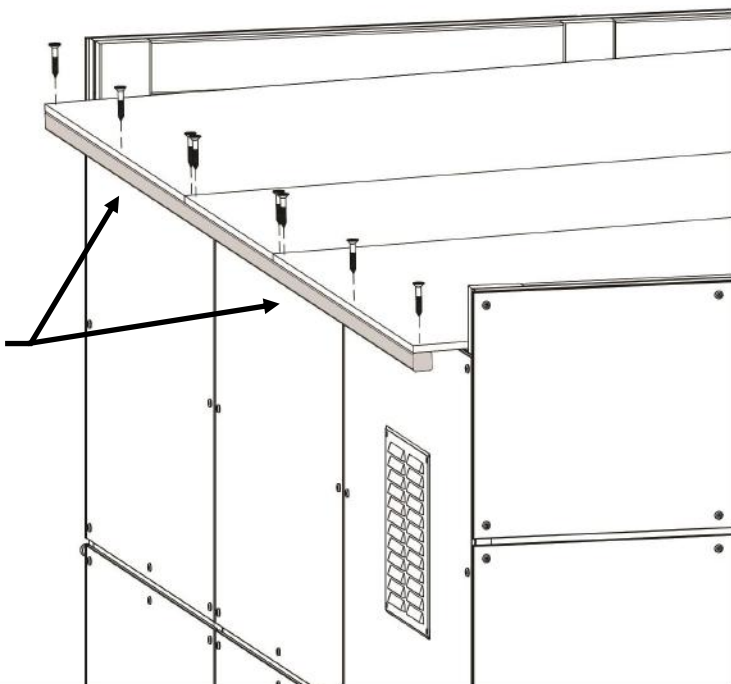

1570

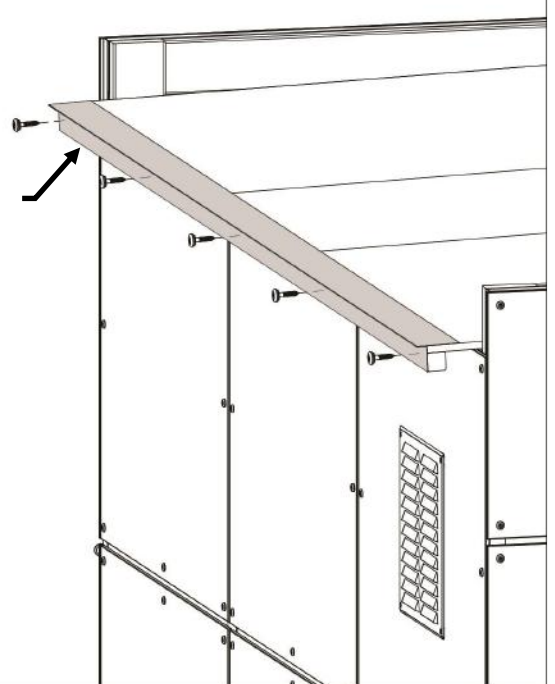

WC201161

86. * Nicht im Lieferumfang enthalten / Not included!

* Dachbanen/ Roof membranes!

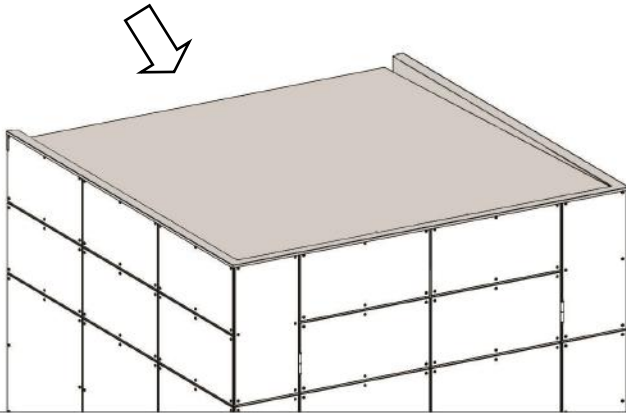

86.1

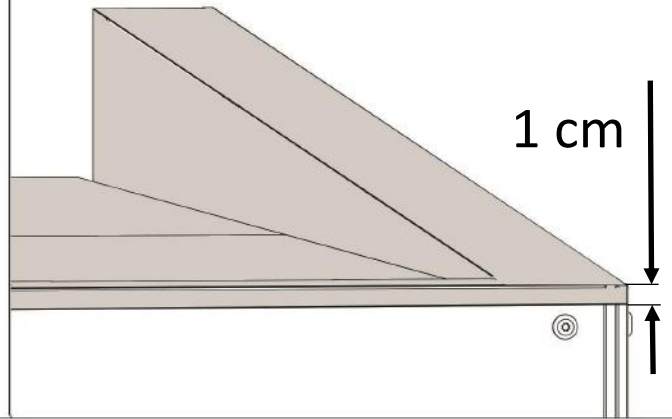

87.

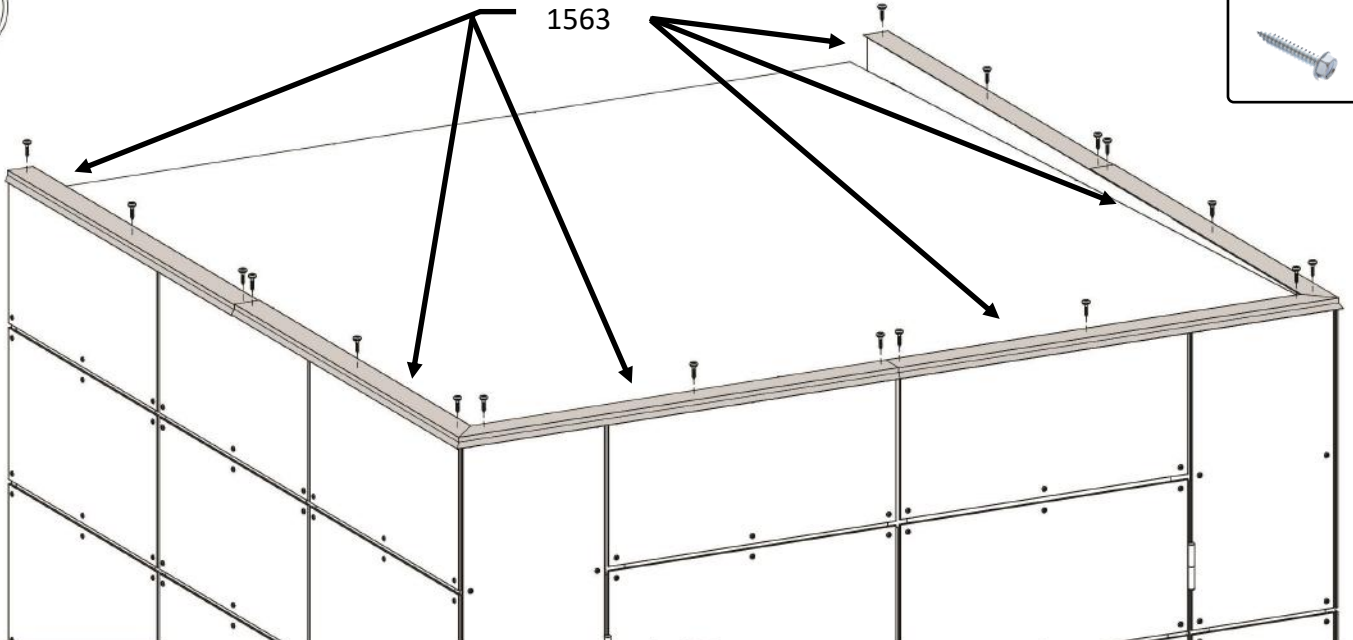

87.1

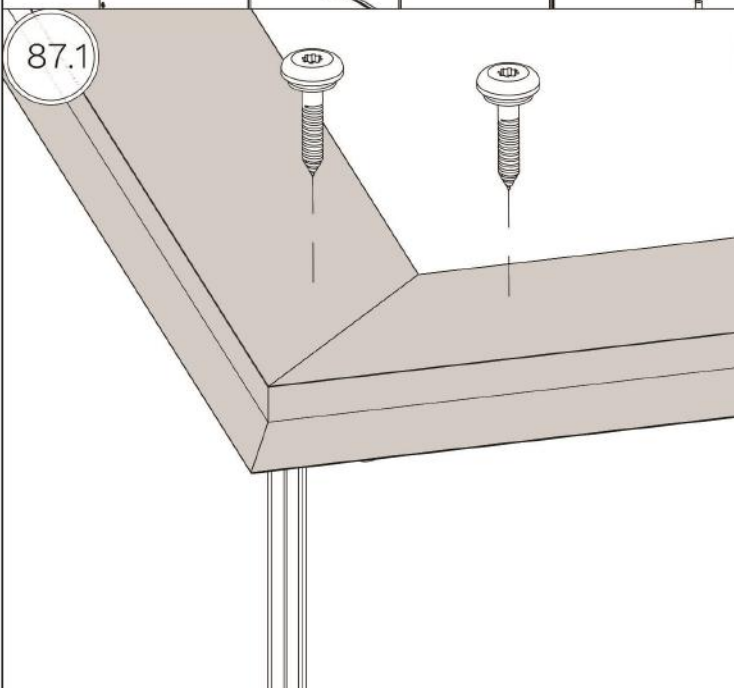

87.2

