

WC201080

V.5

Aufbauanleitung

DE - Bevor Sie beginnen:

- Es ist empfehlenswert sich etwas Zeit zu nehmen, um die Aufbauanleitung zu lesen, bevor mit dem Aufbau begonnen wird.
- Der Aufbau sollte in der vorgegebenen Reihenfolge erfolgen.
- Die Aufbauanleitung dient lediglich als Richtschnur für den Aufbau. Nicht alle Schritte sind im Detail vorgegeben.
- Bitte prüfen Sie alle Teile auf Vollständigkeit und Zustand vor dem Aufbau. Der Aufbau sollte durch mindestens 2 Personen erfolgen.
- Bei starkem Wind sollte der Aufbau nicht erfolgen.
- Bohren Sie die Teile vor, wo es angezeigt wird.
- Wir empfehlen, das Gerätehaus erst nach weitgehendem Aufbau vor Anbringung der Deckleisten mit Farbe oder Holzlasur zu behandeln, da sich die Elemente bei einer einseitigen Behandlung verziehen können, wodurch der Aufbau erschwert werden könnte.

Instructions d'assemblage

FR - Avant de commencer:

- Avant de commencer le processus d'assemblage, veuillez s'il vous plaît vous familiariser parfaitement avec les instructions.
- La maison doit être assemblée suivant la séquence indiquée dans les instructions.
- Les instructions s'entendent comme lignes directrices, toutes les étapes ne sont pas décrites en détails.
- Avant de commencer l'assemblage, vérifier tous les éléments.
- Deux personnes sont nécessaires au minimum pour l'assemblage.
- Ne pas tenter d'assembler la maison dans des conditions de vents forts.
- Percer les trous dans les éléments suivant les marques.

Montage-instructie

NL - Alvorens te beginnen:

- Voordat u begint met de montage raden wij u aan de handleiding grondig door te lezen.
- Bij de montage van het huis dient u de volgorde zoals deze in de handleiding is aangegeven te volgen.
- De handleiding is bedoeld als richtsnoer, niet alle stappen zijn in detail uitgewerkt.
- Vóór de montage dienen alle details gecontroleerd te worden.
- De montage van het huis dient door tenminste twee personen uitgevoerd te worden.
- Het huis nooit in harde wind opbouwen.
- Gat in onderdelen boren, waar dit staat aangegeven.

Pokyny k montáži

CZ - Než začnete:

- Než začnete s montáží, seznámte se důkladně s těmito pokyny.
- Domek musí být sestaven v pořadí uvedeném v pokynech.
- Pokyny slouží pouze jako vodítko, ne všechny kroky jsou zde popsány dopodrobna.
- Než začnete s montáží, zkontrolujte všechny díly.
- K montáži jsou zapotřebí minimálně dvě osoby.
- Nepokoušejte se smontovat domek za silného větru.
- Vyvrtejte do dílů otvory podle značek.

Pokyny pre montáž

SK - Predtým, než začnete:

- Predtým, než začnete montovať, sa, prosím, dôkladne oboznámte s týmito pokynmi.
- Dom je potrebné zmontovať podľa poradia uvedeného v pokynoch.
- Tieto pokyny poskytujú návod, nepopisujú však detailne všetky kroky.
- Predtým, než začnete montovať, skontrolujte všetky časti.
- Pri montáži sú potrební najmenej dvaja ľudia.
- Nepokúšajte sa montovať dom pri silnom vetre.
- Otvory v jednotlivých častiach vyvrtajte podľa označenia.

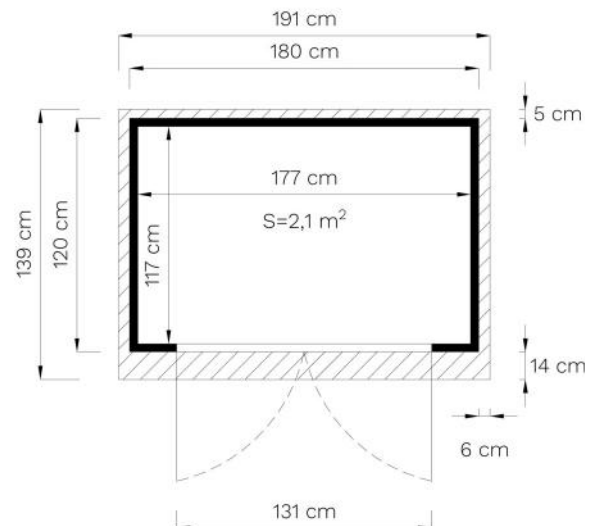
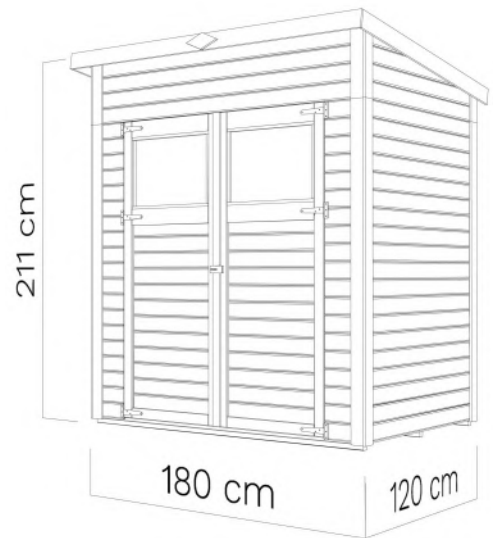











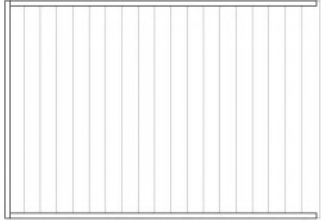
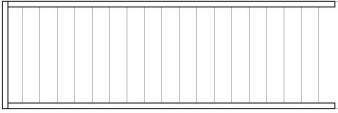
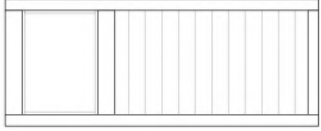
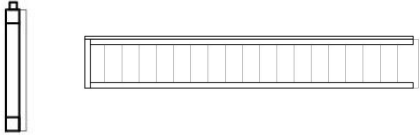
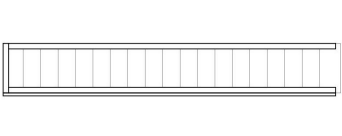
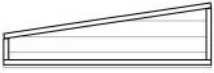





DE - Technische Änderungen vorbehalten.

Alle Maße sind ca. Maße.

















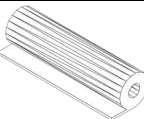





EN - Technical modifications reserved.

All dimensions are approximate dimensions.

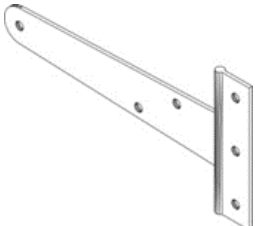
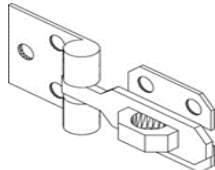
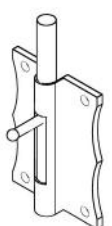
WC201080

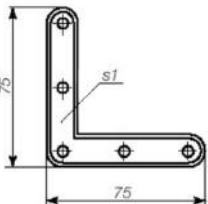
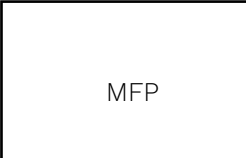
ID	Details in mm (Tolerance/Toleranz ...+ 2mm)	Pcs.	ID	Details in mm (Tolerance/Toleranz ...+ 2mm)	Pcs.
918	16 x 1174 x 1770 	x 1	231	42 x 1174 x 1703 	x 3
232	42 x 540 x 1703 	x 1	317	30 x 665 x 1655 	x 2
315	42 x 201 x 1703 	x 1	314	42 x 201 x 1703 	x 1
239	42 x 365 x 1174 	x 1	240	42 x 365 x 1174 	x 1
241	42 x 361 x 1714 	x 1	242	42 x 185 x 1714 	x 1
837	28 x 80 x 1174 	x 2	922	28 x 28 x 1770 	x 3
823	28 x 28 x 1324 	x 2	802	28 x 28 x 945 	x 4
822	28 x 28 x 1312 	x 1	651	12 x 90 x 1390 	x 2
638	12 x 90 x 957 	x 2	623	12 x 70 x 1680 	x 9
603	12 x 70 x 360 	x 4	601	12 x 70 x 180 	x 4
590	12 x 42 x 1680 	x 4	568	12 x 42 x 360 	x 2

WC201080

ID	Details in mm (Tolerance/Toleranz ...+ 2mm)	Pcs.	ID	Details in mm (Tolerance/Toleranz ...+ 2mm)	Pcs.
565	12 x 42 x 180 	x 2	929	12 x 42 x 807 	x 2
925	12 x 42 x 728 	x 2	926	12 x 42 x 202 	x 1
703	15 x 15 x 529 	x 4	1000	15 x 15 x 384 	x 4
536	1 x 1000 x 2000 	x 2	1508	Ø4 x 25 	x 8
628	12 x 90 x 201 	x 1	1552	3 x 540 x 395 	x 2
1505	Ø4,5 x 50 	x 60	1506	Ø3,5 x 35 	x147
1507	Ø3,5 x 30 	x 50	1509	Ø3 x 19 	x 30
1512	Ø1,4 x 25 	x 28	1513	Ø3 x 10 	x96
1516		x 6	1518		x 1
1517		x 2	1562	Ø3 x 25  	x20 x 4
516	12 x 830 x 1150 	x 2	679	12 x 230 x 1150 	x 1
678	12 x 230 x 830 	x 2	676	12 x 230 x 230 	x 1
1556		x 1			

NB!

Empfohlen bei Aufbau auf besonders feuchtem Untergrund. **(Nicht im Lieferumfang enthalten!)**

Recommended for assembly on moist ground. **(Not included!)**

* Unterlegpads /

* Patio Pads

Min. 4,7 lfm/rm

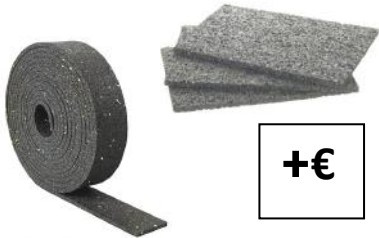

+€

* Imprägniert Kantholz /

* Impregnated beam

40*60*1174 mm

4 St./Pcs



+€

* Schraube /

* Screw

4,5*70 mm

12 St./Pcs



+€

Fundamentplan / Foundation Plan

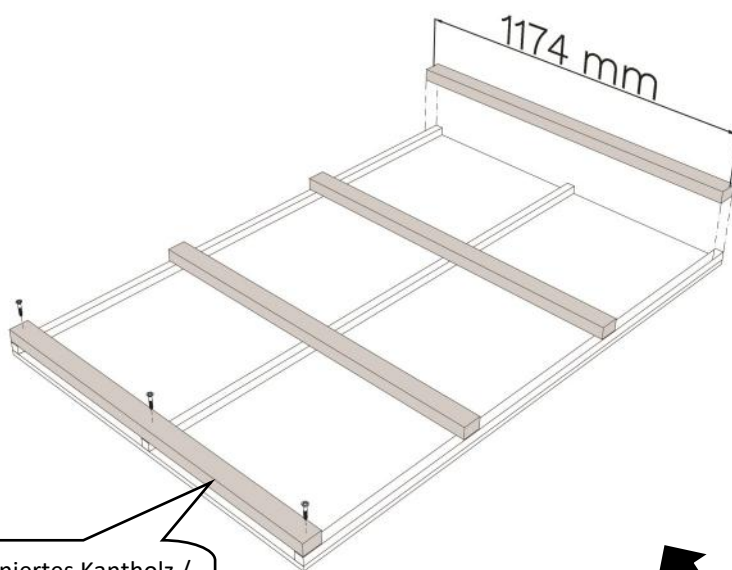
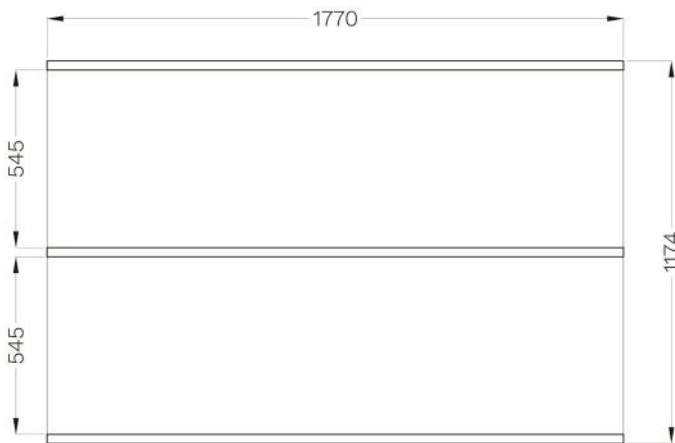

Imprägniertes Kantholz /
Impregnated beam

Holzschutzmittel /
Wood preservative

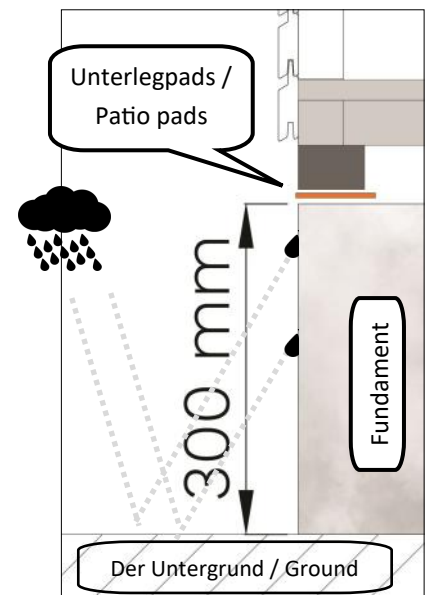

Vor dem Aufbau!

Bitte erkundigen Sie sich vor der Montage, ob für den Bau eine Genehmigung erforderlich ist.

Before installation!

Prior to assembly please check whether a permit is required.

WC201080

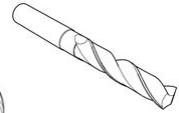
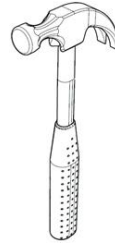
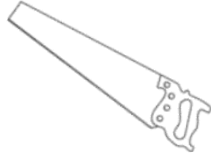
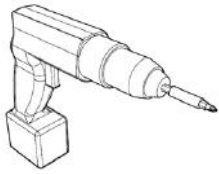

Ø 4 mm

Ø 8 mm

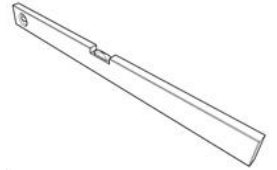

1.

35 mm x 18 St

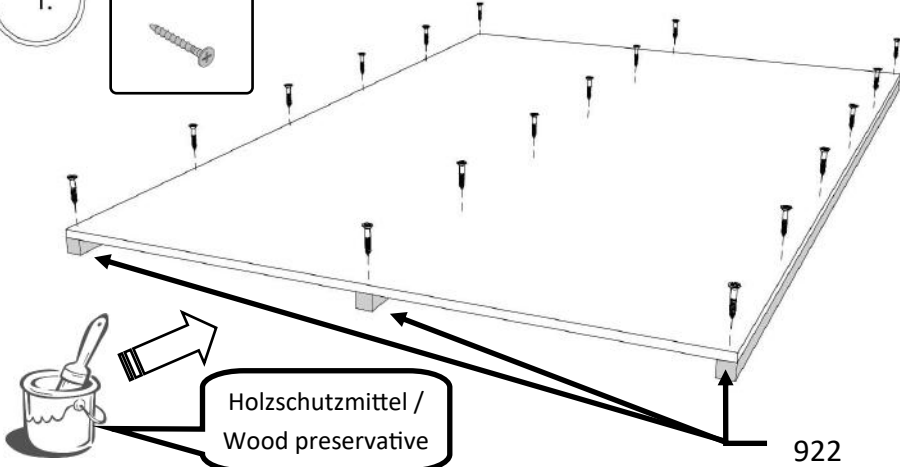

922

2.



Holzschutzmittel /
Wood preservative

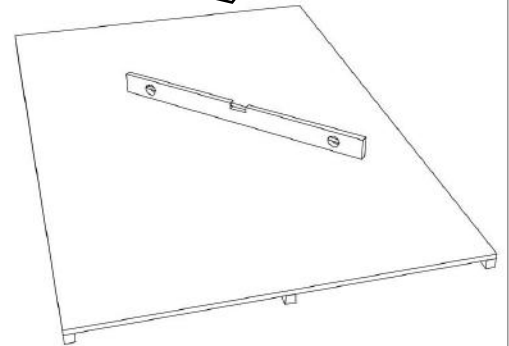

1.1

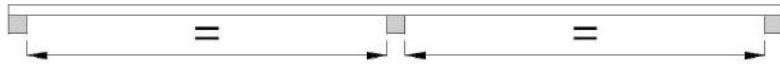

3.

4 mm



50 mm x 15 St

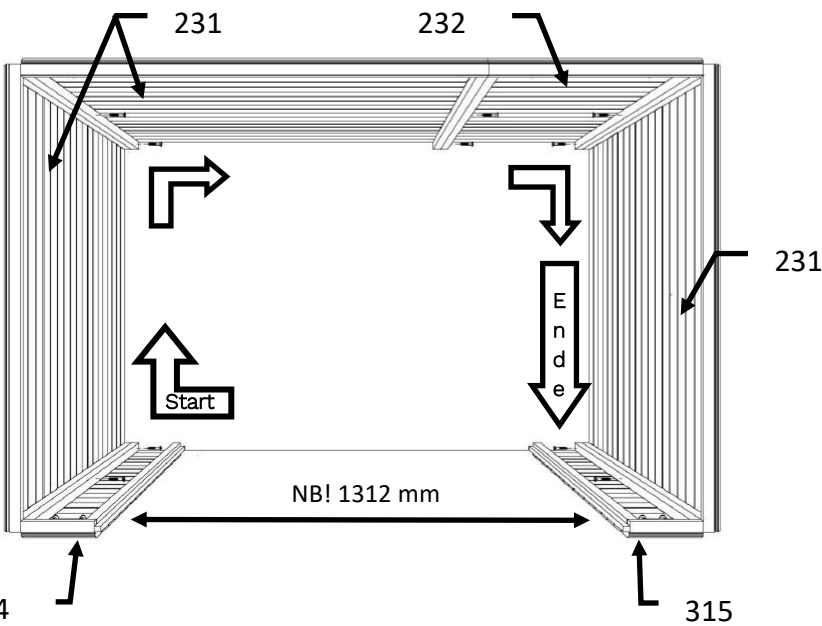

1x

3.1

4x

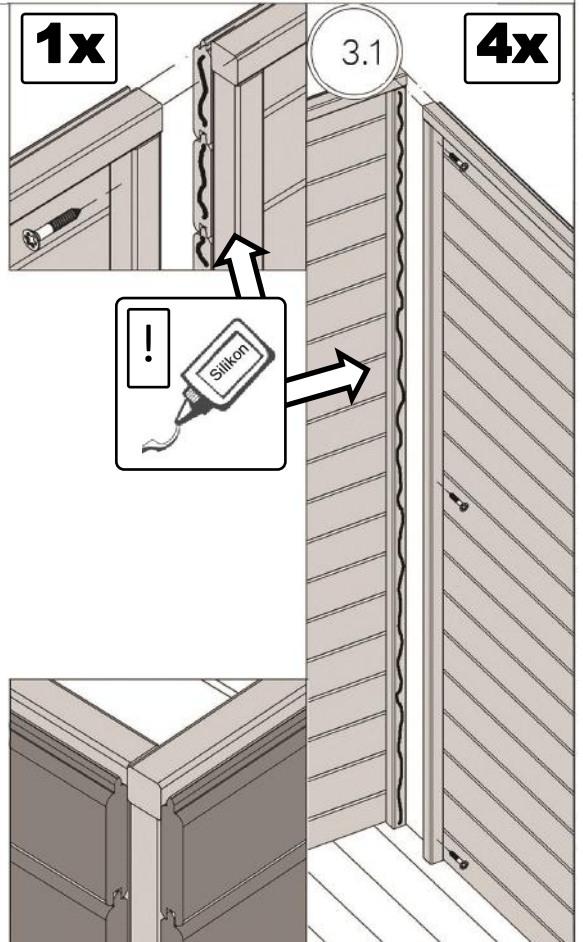

WC201080

5.

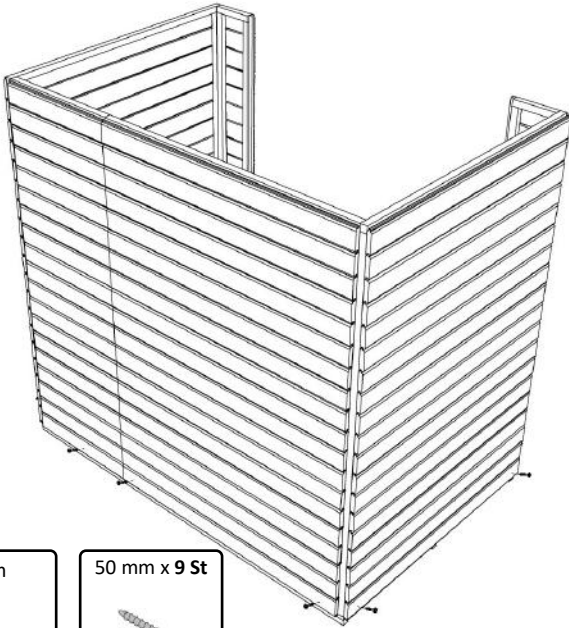

4 mm

50 mm x 9 St

7.

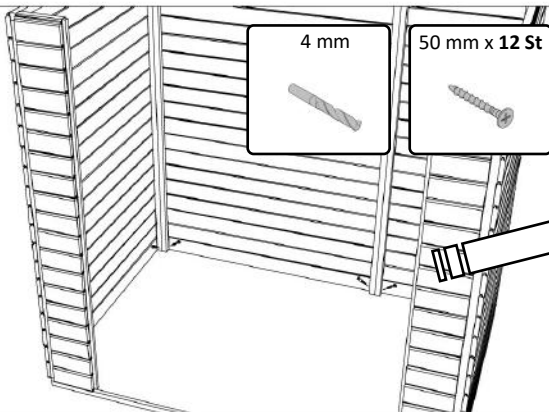

4 mm

50 mm x 12 St

6.

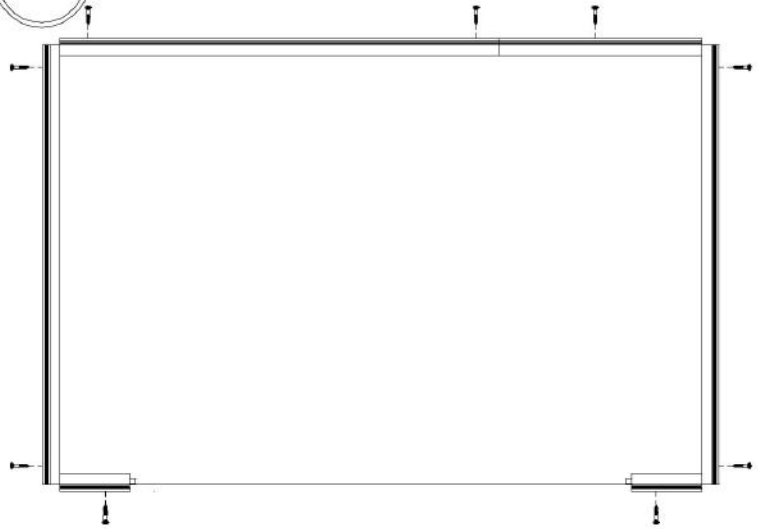

7.1

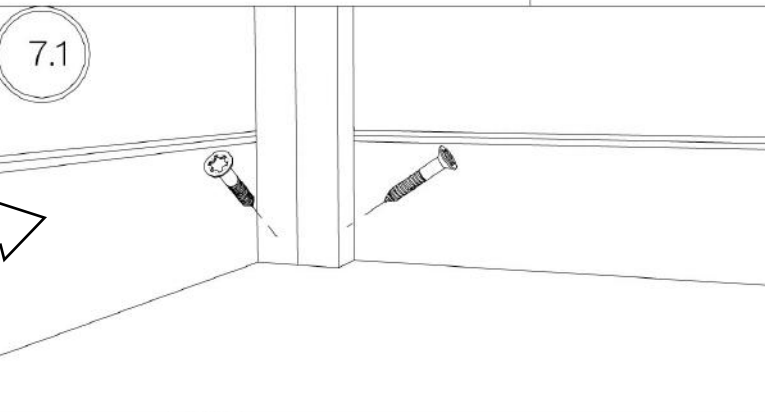

8.

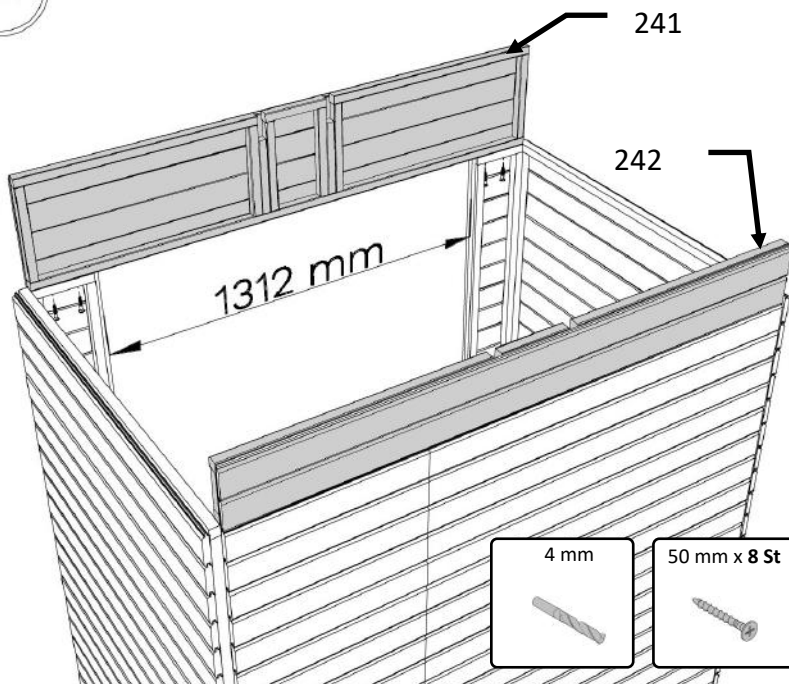

241

242

1312 mm

4 mm

50 mm x 8 St

9.

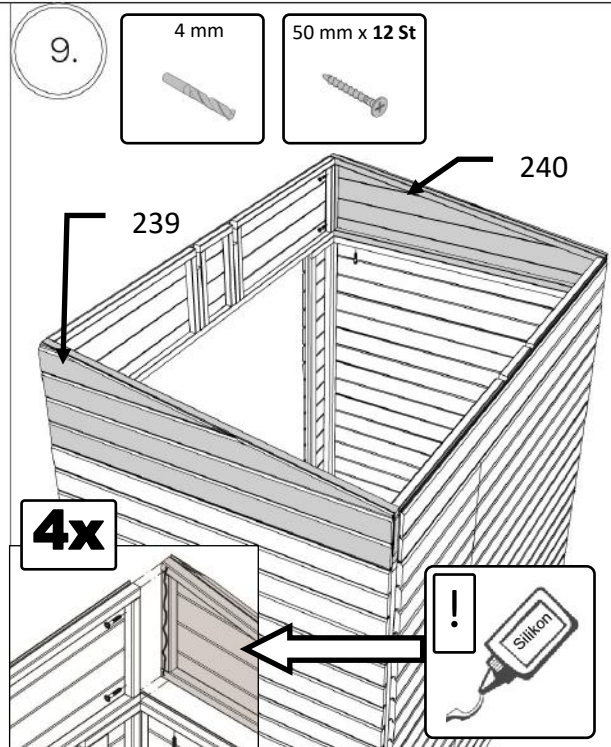

4 mm

50 mm x 12 St

240

239

4x

!

Silikon

WC201080

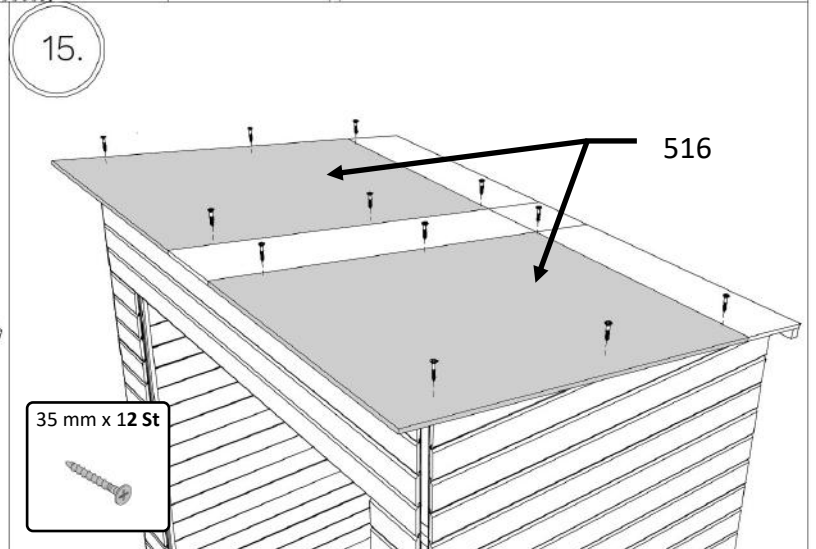
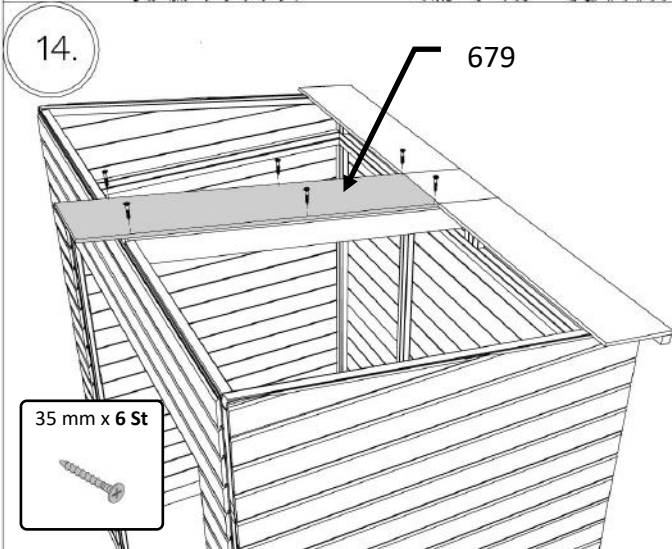
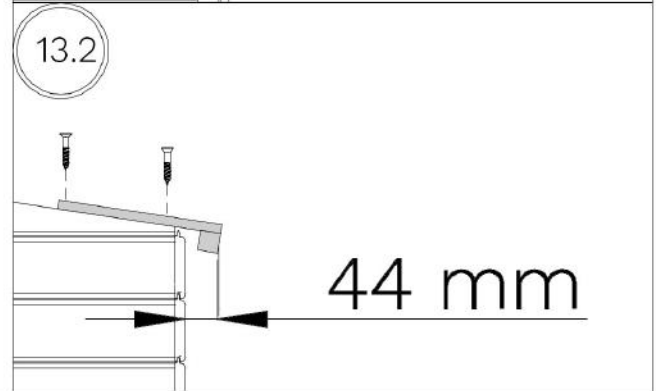
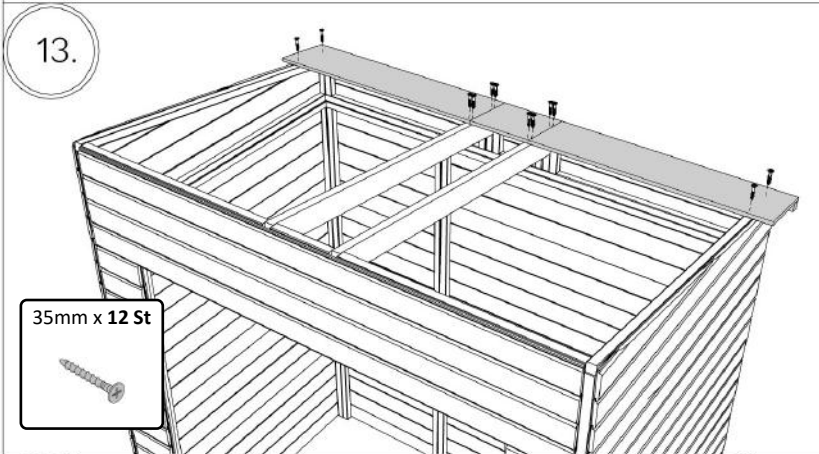
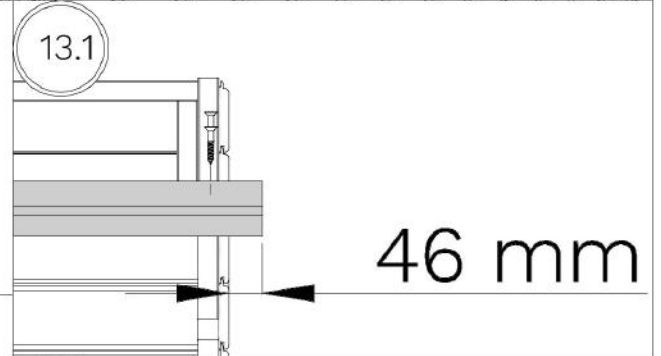
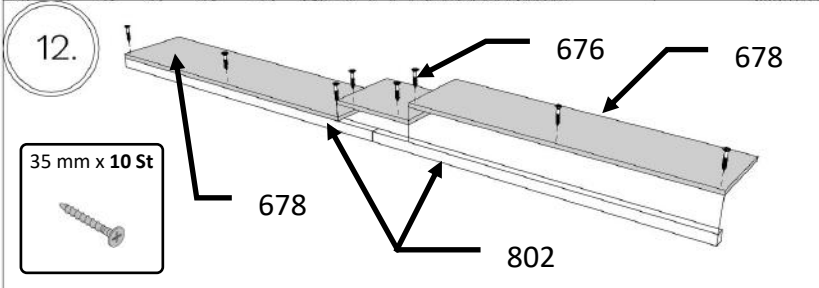
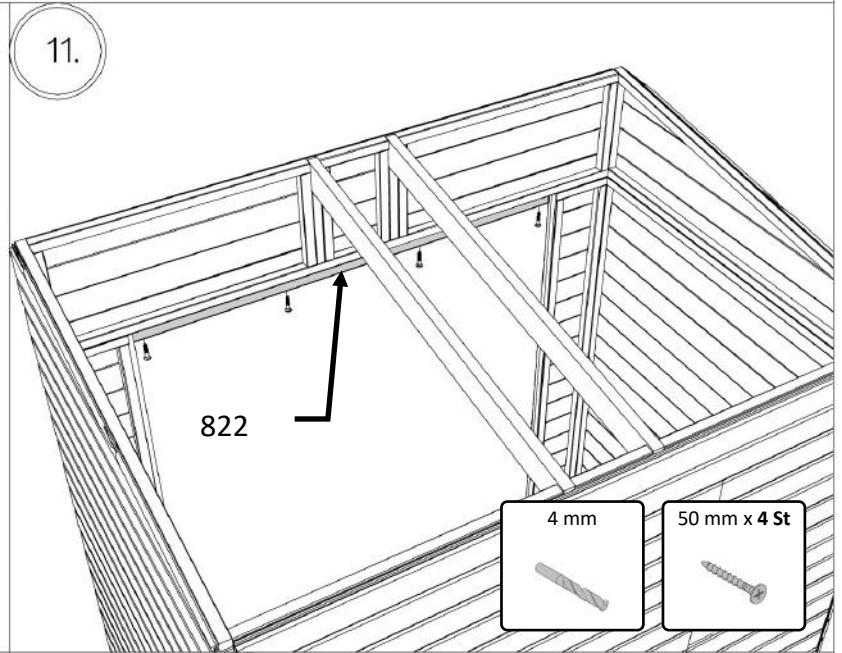
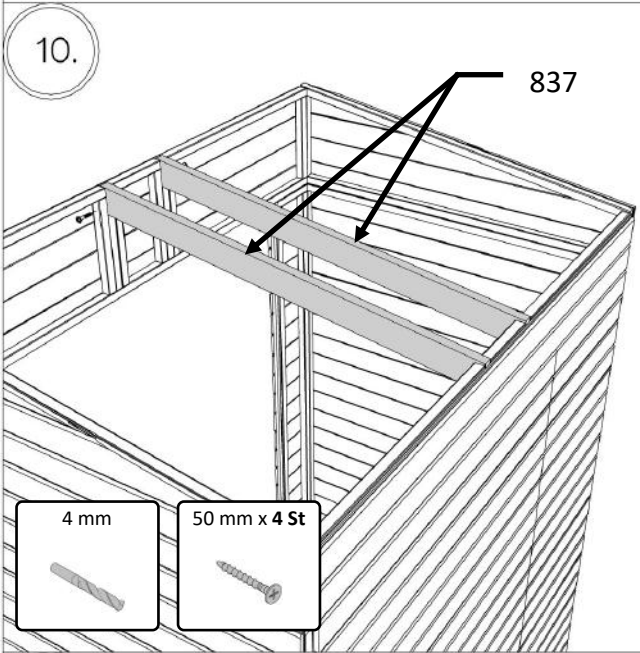

WC201080

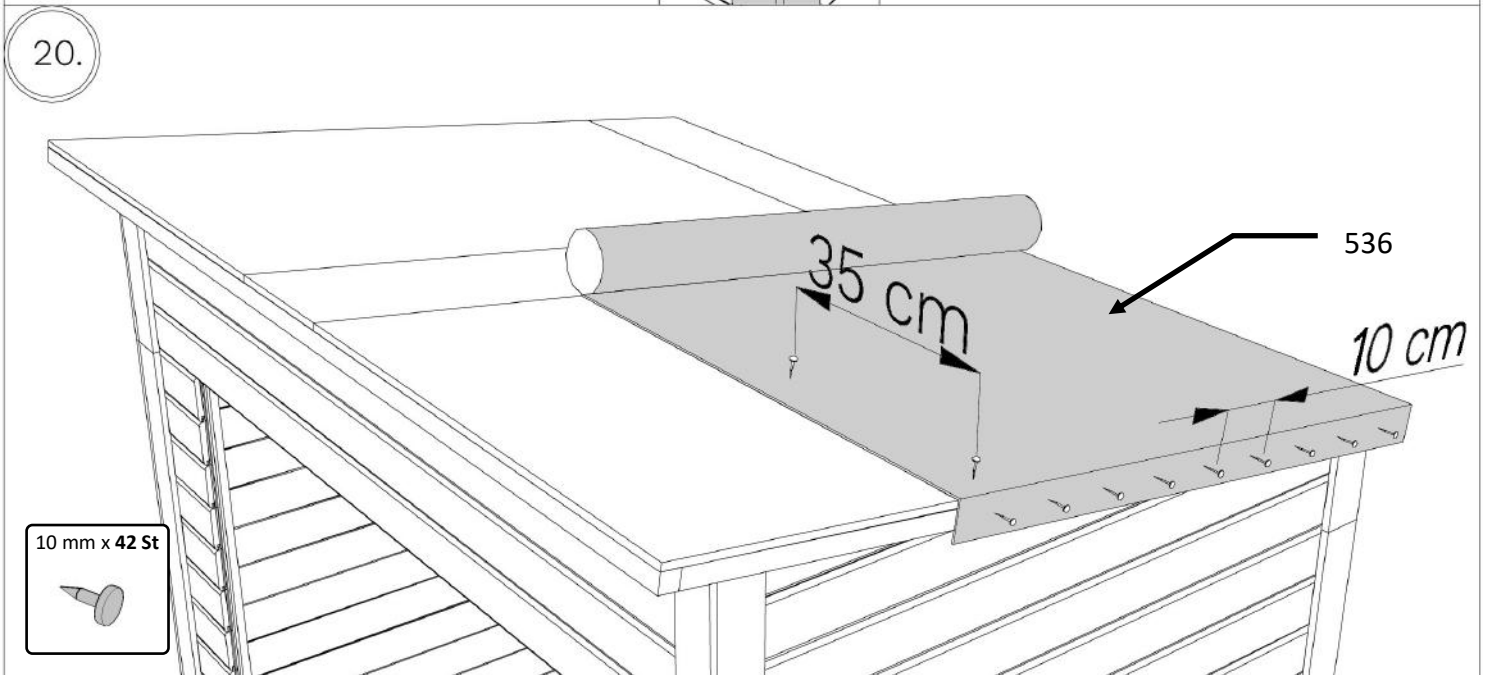
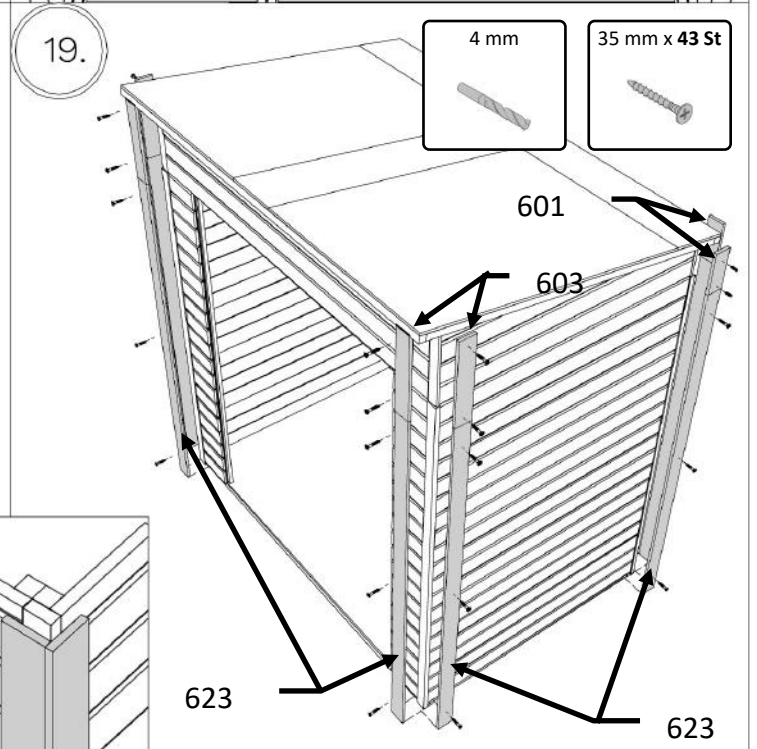
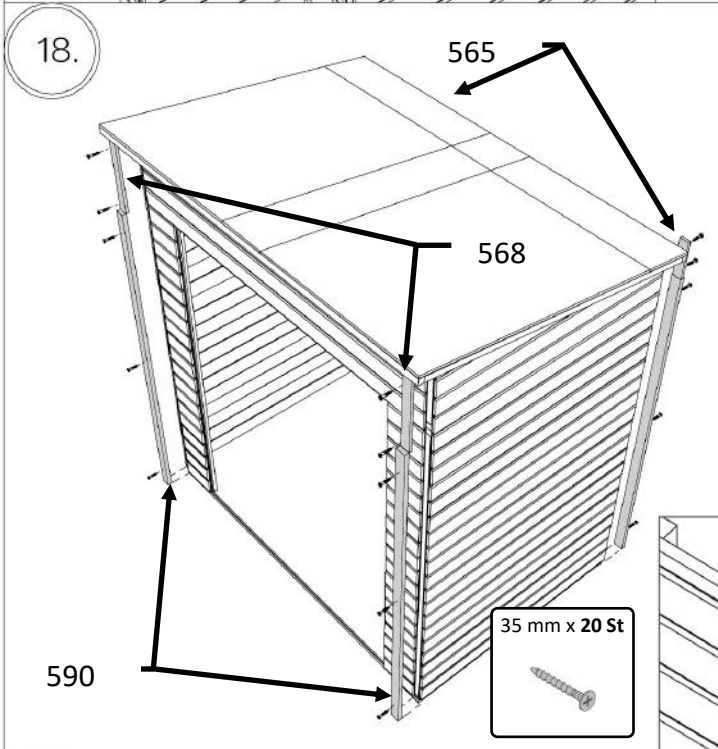
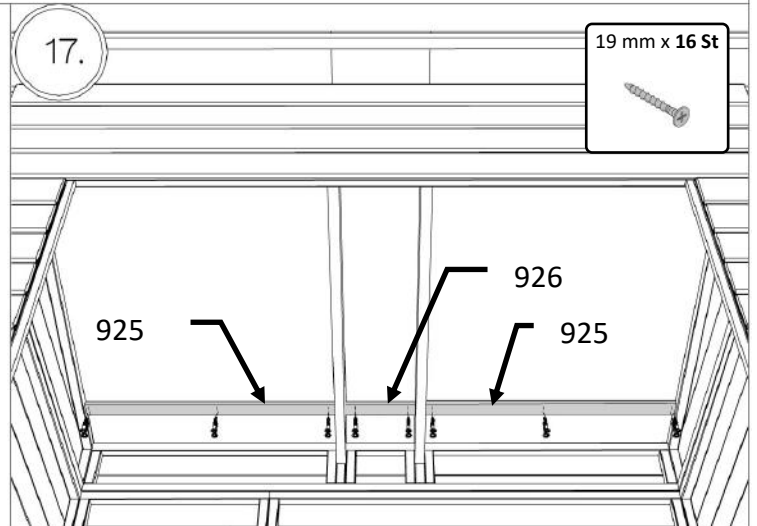
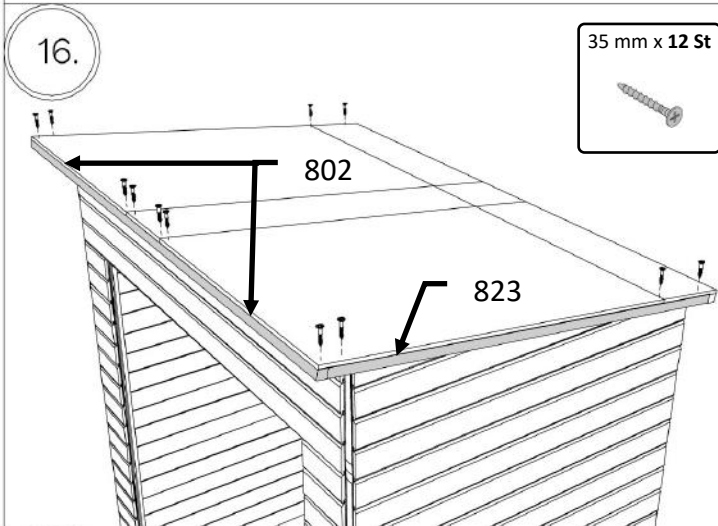

WC201080

21.

10 mm x 54 St

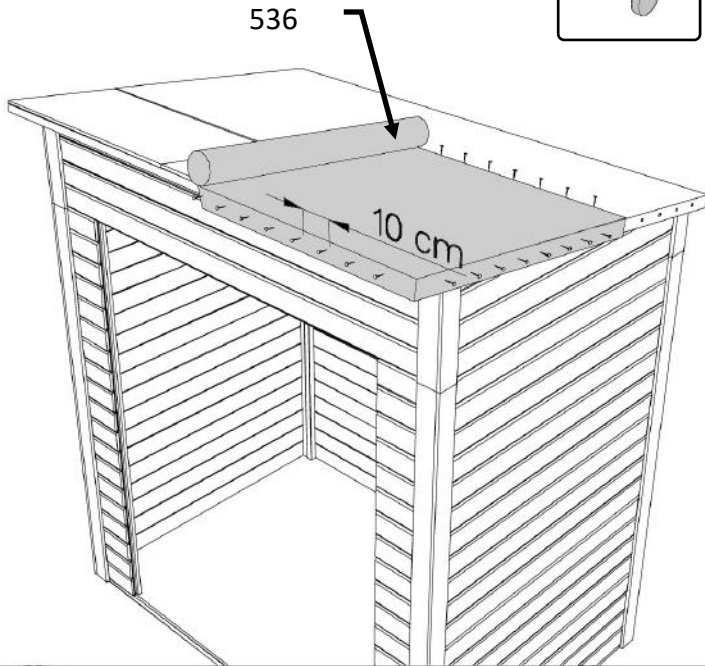

22.

35 mm x 14 St



4 mm

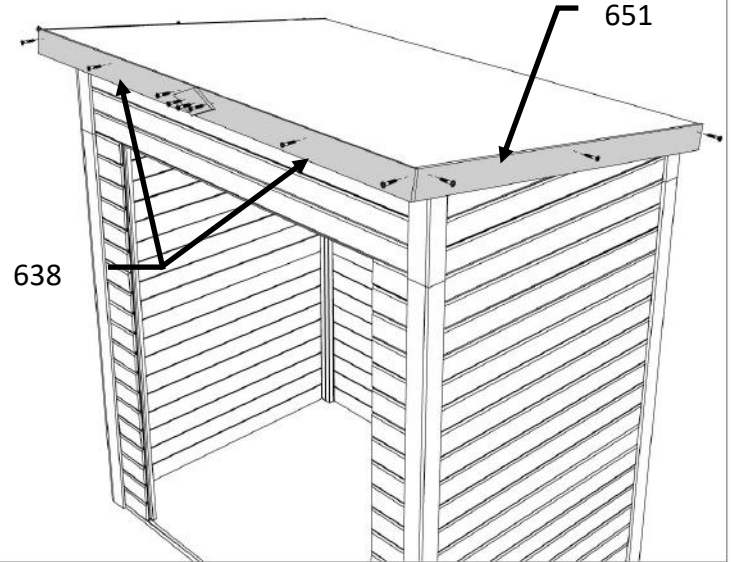

23.

1552

25 mm x 14 St



703

1000

2x

1516

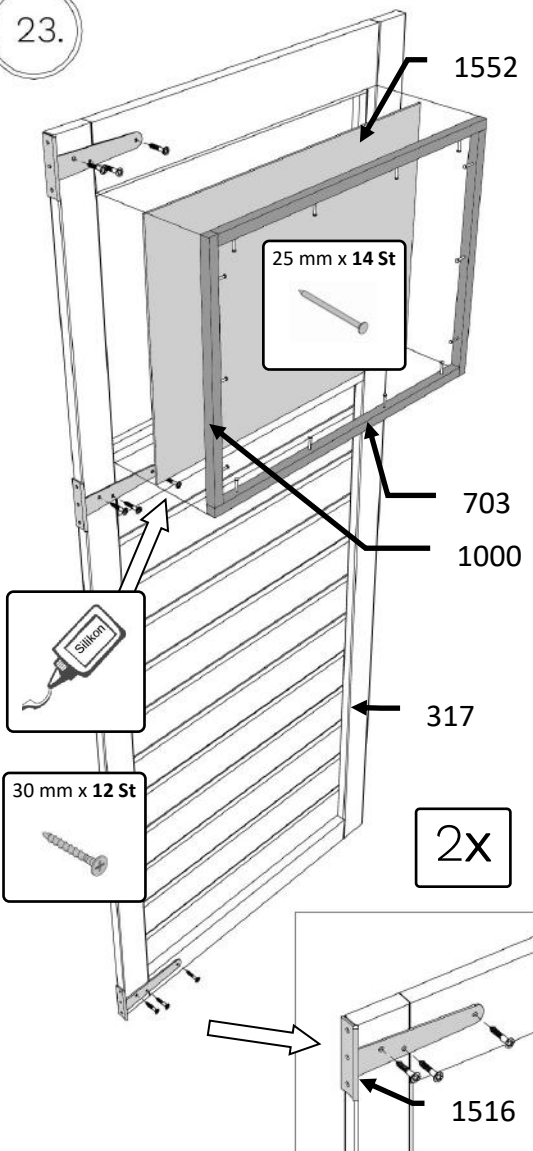

24.

317

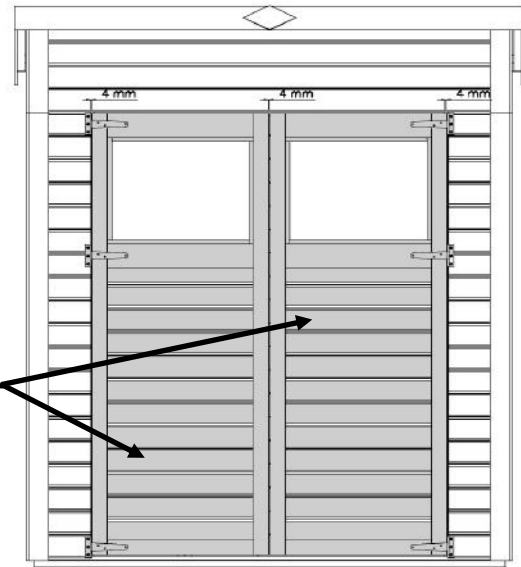

30 mm x 18 St



24.1

4 mm

4 mm

4 mm

25.

26.

30 mm x 4 St



1517

317

918

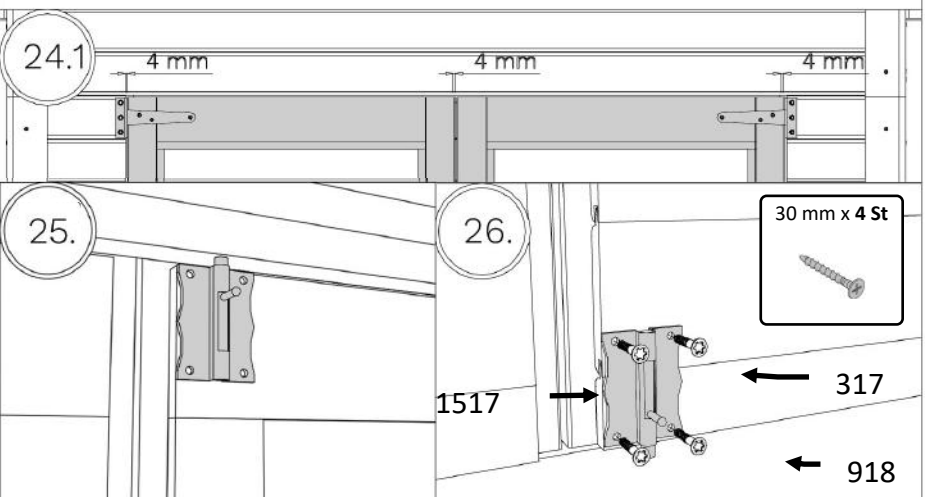

WC201080

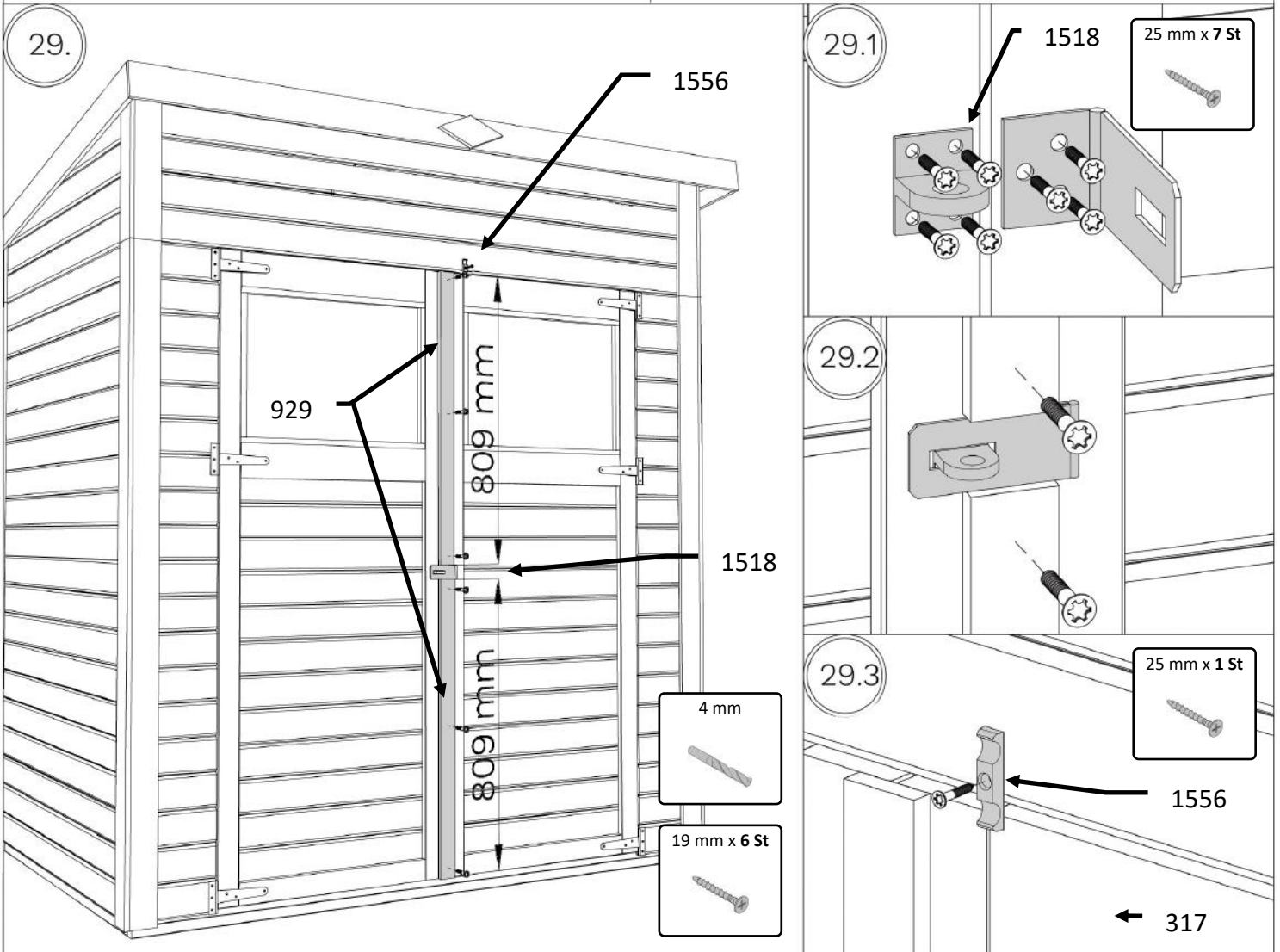
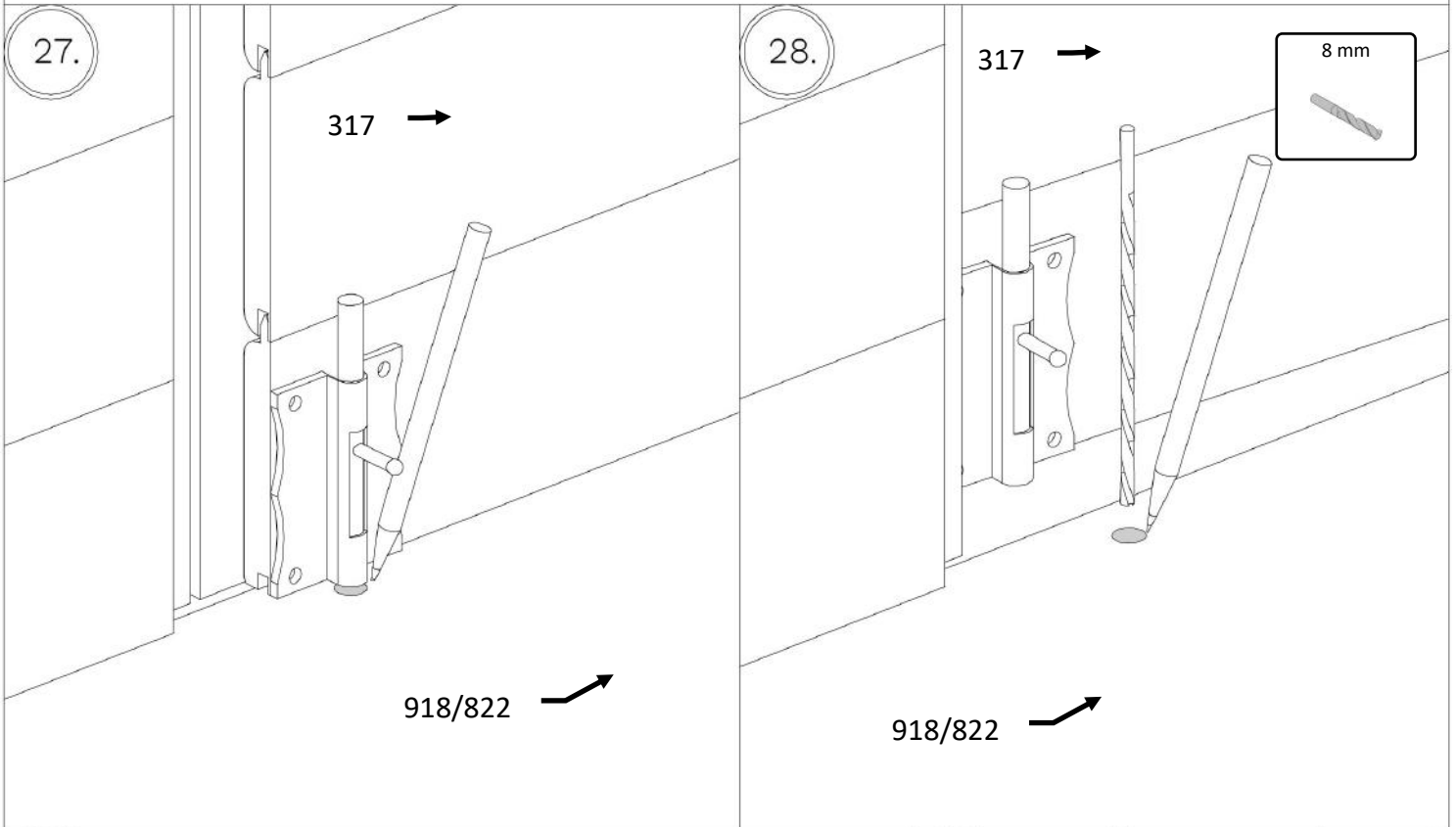

WC201080

30.

1562

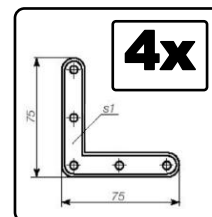
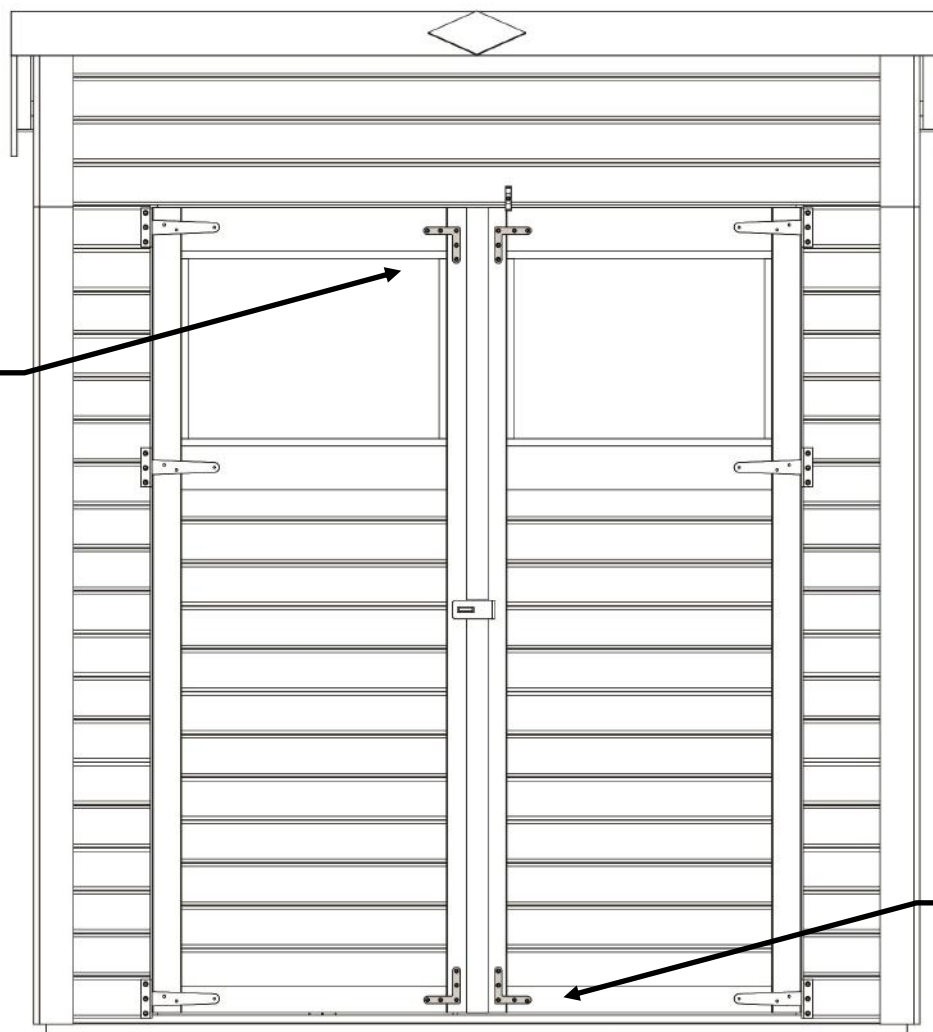

25 mm x 20 St



1562

30.1

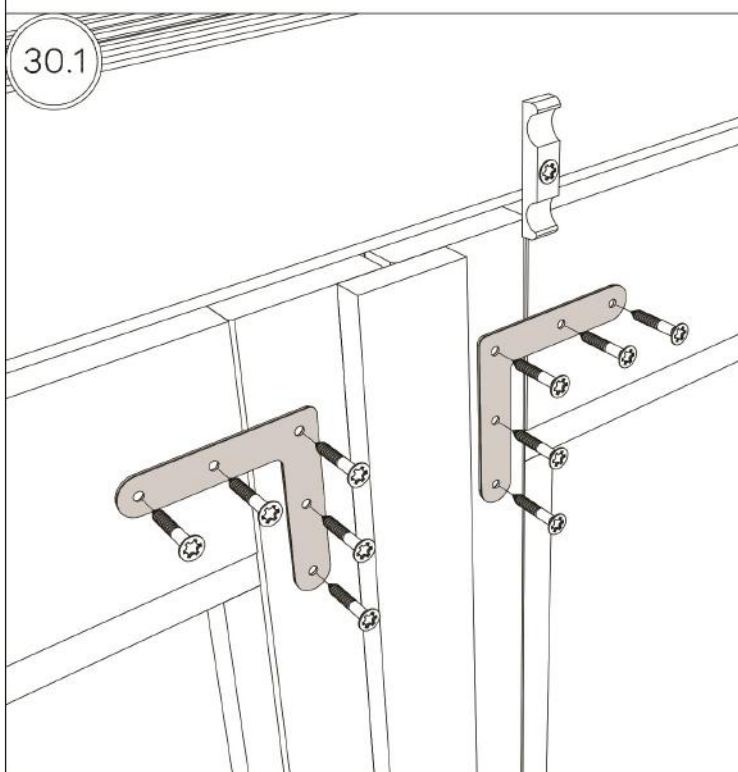

30.2

