

# WC201040

## Aufbauanleitung

DE - Bevor Sie beginnen:

- Es ist empfehlenswert sich etwas Zeit zu nehmen, um die Aufbauanleitung zu lesen, bevor mit dem Aufbau begonnen wird.
- Der Aufbau sollte in der vorgegebenen Reihenfolge erfolgen.
- Die Aufbauanleitung dient lediglich als Richtschnur für den Aufbau. Nicht alle Schritte sind im Detail vorgegeben.
- Bitte prüfen Sie alle Teile auf Vollständigkeit und Zustand vor dem Aufbau. Der Aufbau sollte durch mindestens 2 Personen erfolgen.
- Bei starkem Wind sollte der Aufbau nicht erfolgen.
- Bohren Sie die Teile vor, wo es angezeigt wird.
- Wir empfehlen, das Gerätehaus erst nach weitgehendem Aufbau vor Anbringung der Deckleisten mit Farbe oder Holzlasur zu behandeln, da sich die Elemente bei einer einseitigen Behandlung verziehen können, wodurch der Aufbau erschwert werden könnte.

## Instructions d'assemblage

FR - Avant de commencer:

- Avant de commencer le processus d'assemblage, veuillez s'il vous plaît vous familiariser parfaitement avec les instructions.
- La maison doit être assemblée suivant la séquence indiquée dans les instructions.
- Les instructions s'entendent comme lignes directrices, toutes les étapes ne sont pas décrites en détails.
- Avant de commencer l'assemblage, vérifiez tous les éléments.
- Deux personnes sont nécessaires au minimum pour l'assemblage.
- Ne pas tenter d'assembler la maison dans des conditions de vents forts.
- Percer les trous dans les éléments suivant les marques.

## Montage-instructie

NL - Alvorens te beginnen:

- Voordat u begint met de montage raden wij u aan de handleiding grondig door te lezen.
- Bij de montage van het huis dient u de volgorde zoals deze in de handleiding is aangegeven te volgen.
- De handleiding is bedoeld als richtsnoer, niet alle stappen zijn in detail uitgewerkt.
- Vóór de montage dienen alle details gecontroleerd te worden.
- De montage van het huis dient door tenminste twee personen uitgevoerd te worden.
- Het huis nooit in harde wind opbouwen.
- Gaten in onderdelen boren, waar dit staat aangegeven.

## Pokyny k montáži

CZ - Než začnete:

- Než začnete s montáží, seznámte se důkladně s těmito pokyny.
- Domek musí být sestaven v pořadí uvedeném v pokynech.
- Pokyny slouží pouze jako vodítko, ne všechny kroky jsou zde popsány dopodrobna.
- Než začnete s montáží, zkontrolujte všechny díly.
- K montáži jsou zapotřebí minimálně dvě osoby.
- Nepokoušejte se smontovat domek za silného větru.
- Vyvrtajte do dílů otvory podle značek.

## Pokyny pre montáž

SK - Predtým, než začnete:

- Predtým, než začnete montovať, sa, prosím, dôkladne oboznámte s týmito pokynmi.
- Dom je potrebné zmontovať podľa poradia uvedeného v pokynoch.
- Tieto pokyny poskytujú návod, nepopisujú však detailne všetky kroky.
- Predtým, než začnete montovať, skontrolujte všetky časti.
- Pri montáži sú potrební najmenej dvaja ľudia.
- Nepokúšajte sa montovať dom pri silnom vetre.
- Otvory v jednotlivých častiach vyvrtajte podľa označenia.

1.

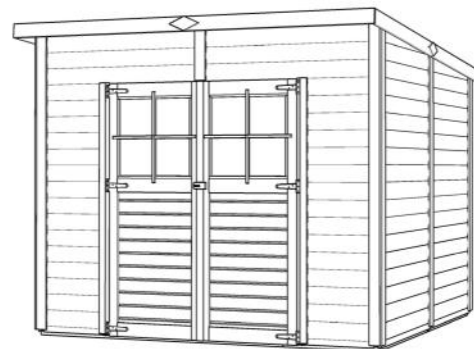



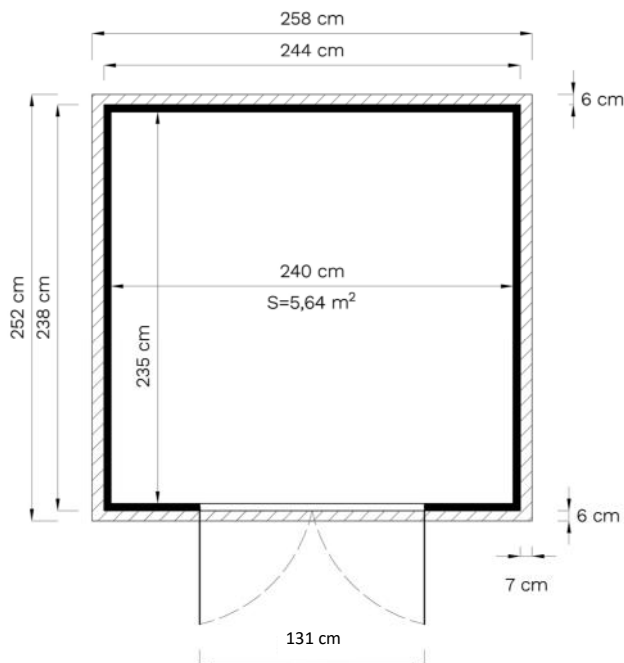
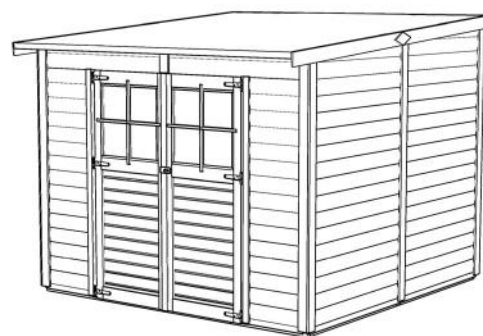







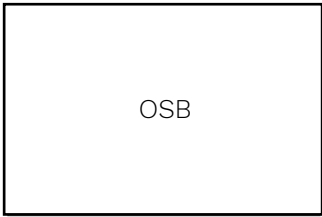
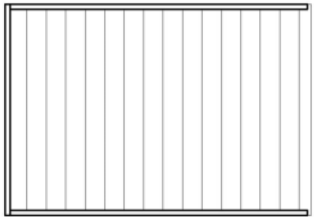





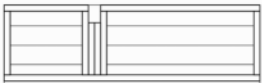





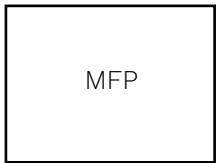

2.





















DE - Technische Änderungen vorbehalten.  
Alle Maße sind ca. Maße.  
EN - Technical modifications reserved.  
All dimensions are approximate dimensions.

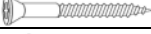
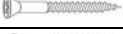

# WC201040

ID	Details in mm (Tolerance/Toleranz ...+ 2mm)	Pcs.	ID	Details in mm (Tolerance/Toleranz ...+ 2mm)	Pcs.
1107	15 x 1174 x 1770 	x 2	283	47 x 1174 x 1703 	x 6
310	47 x 365 x 1174 	x 1	311	15 x 365 x 1174 	x 1
312	47 x 276 x 1174 	x 1	313	47 x 276 x 1174 	x 1
291	47 x 518 x 1703 	x 1	292	47 x 518 x 1703 	x 1
304	47 x 361 x 1174 	x 1	305	47 x 361 x 1174 	x 1
306	47 x 185 x 1174 	x 1	307	47 x 185 x 1174 	x 1
259	29 x 665 x 1690 	x 2	1106	15 x 634 x 1174 	x 2
516	12 x 830 x 1150 	x 6	691	12 x 230 x 830 	x 3
932	28 x 80 x 1650 	x 4	1108	28 x 80 x 698 	x 4
816	28 x 28 x 1237 	x 8	822	28 x 28 x 1312 	x 1
920	28 x 28 x 1174 	x 17	1105	28 x 28 x 578 	x 2
645	12 x 90 x 1267 	x 6	623	12 x 70 x 1680 	x 11
603	12 x 70 x 360 	x 7	601	12 x 70 x 180 	x 5

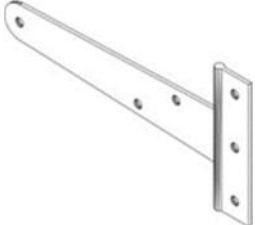
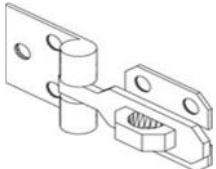
# WC201040

ID	Details in mm (Tolerance/Toleranz ...+ 2mm)	Pcs.	ID	Details in mm (Tolerance/Toleranz ...+ 2mm)	Pcs.
<b>738</b>	17,5 x 45 x 1680 	x 4	<b>731</b>	17,5 x 45 x 774 	x 2
<b>727</b>	17,5 x 45 x 731 	x 4	<b>717</b>	17,5 x 45 x 360 	x 2
<b>715</b>	17,5 x 45 x 180 	x 2	<b>1102</b>	12 x 45 x 825 	x 2
<b>703</b>	15 x 15 x 529 	x 8	<b>704</b>	15 x 15 x 600 	x 4
<b>628</b>	12 x 90 x 201 	x 3	<b>558</b>	3 x 540 x 540 	x 2
<b>1505</b>	Ø4,5 x 50 	x150	<b>1506</b>	Ø3,5 x 35 	x240
<b>1507</b>	Ø3,5 x 30 	x 44	<b>1508</b>	Ø4 x 25 	x 36
<b>1509</b>	Ø3 x 20 	x 7	<b>1512</b>	Ø1,4 x 25 	x 36
<b>1513</b>	Ø3 x 10 	x164			
<b>1516</b>		x 6	<b>1518</b>		x 1
<b>1517</b>		x 2	<b>540</b>	3 x 1000 x 2600 	x 3

# WC201040

**NB!** Empfohlen bei Aufbau auf besonders feuchtem Untergrund. (**Nicht im Lieferumfang enthalten!**)

Recommended for assembly on moist ground. (**Not included!**)

\* Unterlegpads /  
\* Patio Pads

Min. 16,9 lfm/rm

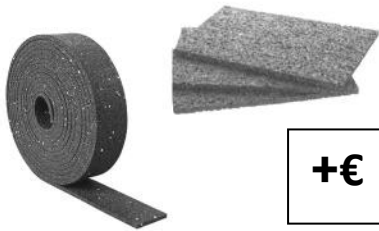

+€

\* Imprägniert Kantholz /  
\* Impregnated beam

40\*60\*2404 mm

7 St./Pcs



+€

\* Schraube /  
\* Screw

4,5\*60 mm

42 St./Pcs



+€

## Fundamentplan / Foundation Plan

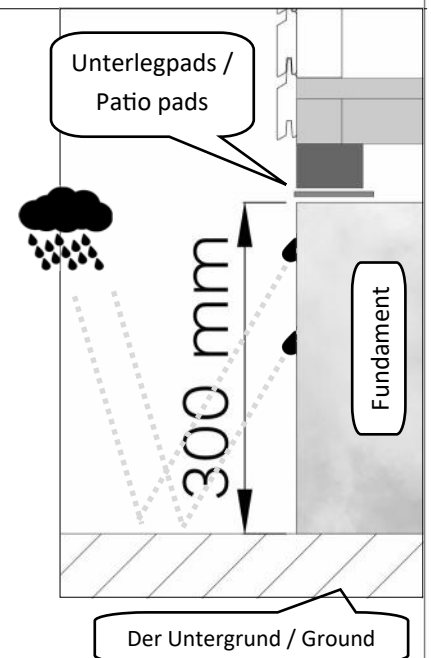
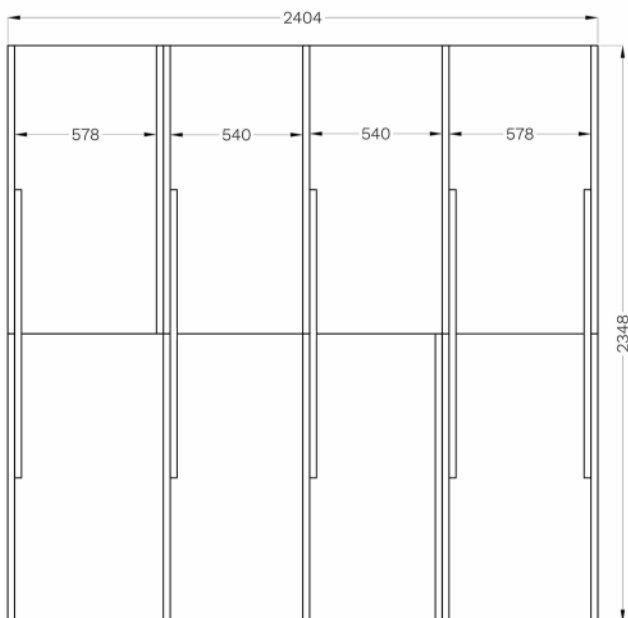

Imprägniertes Kantholz /  
Impregnated beam

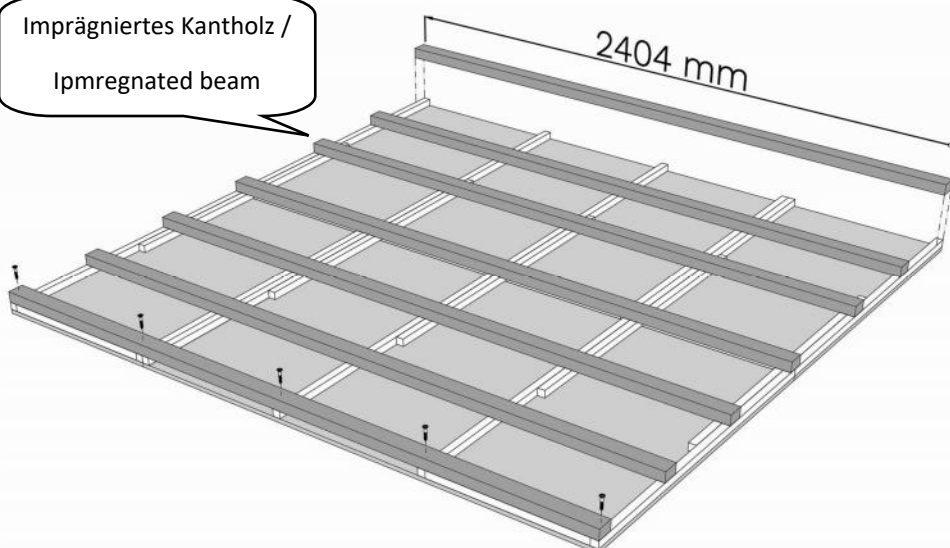

### Bitte beachten!

Lass Dein Bauvorhaben vorab bei Deiner zuständigen Gemeinde prüfen, denn die Bauordnungen sowie die Bebauungspläne müssen eingehalten werden.

### Please note!

Have your construction project checked in advance at your responsible municipality, because the building regulations and the development plans must be observed.

# WC201040

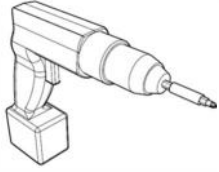

Ø 4 mm

Ø 8 mm



1.

3X

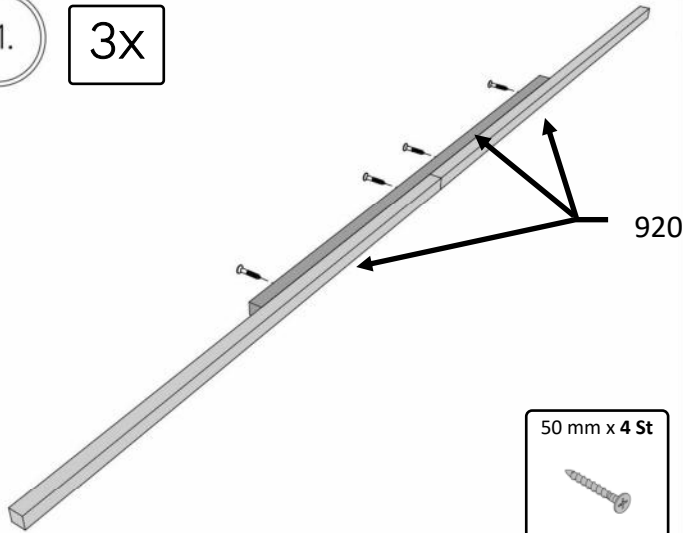

2.

2X

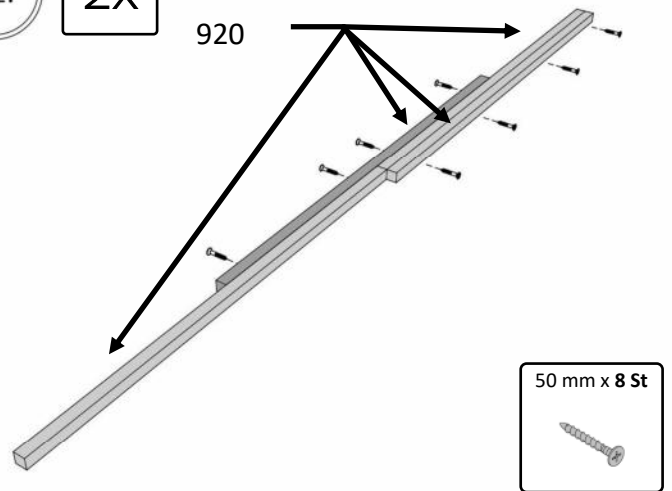

3.

35 mm x 10 St

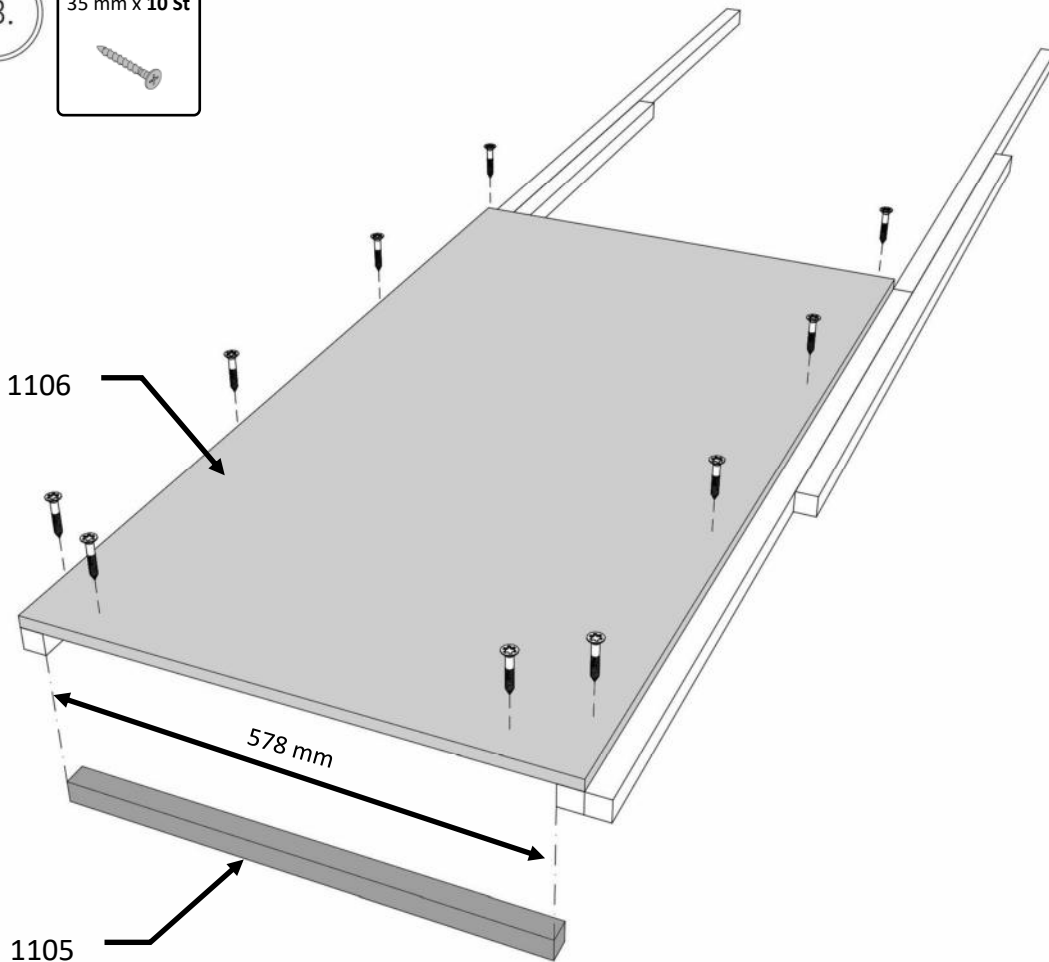

3.1.3.1

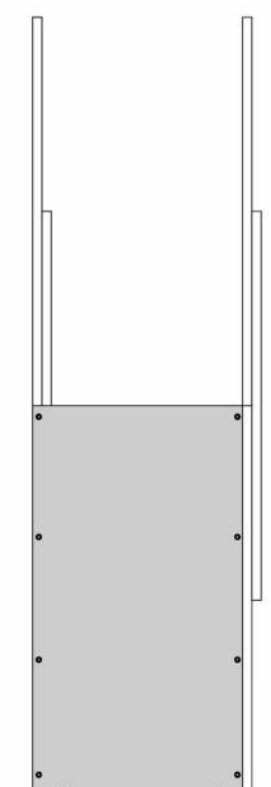

# WC201040

4.

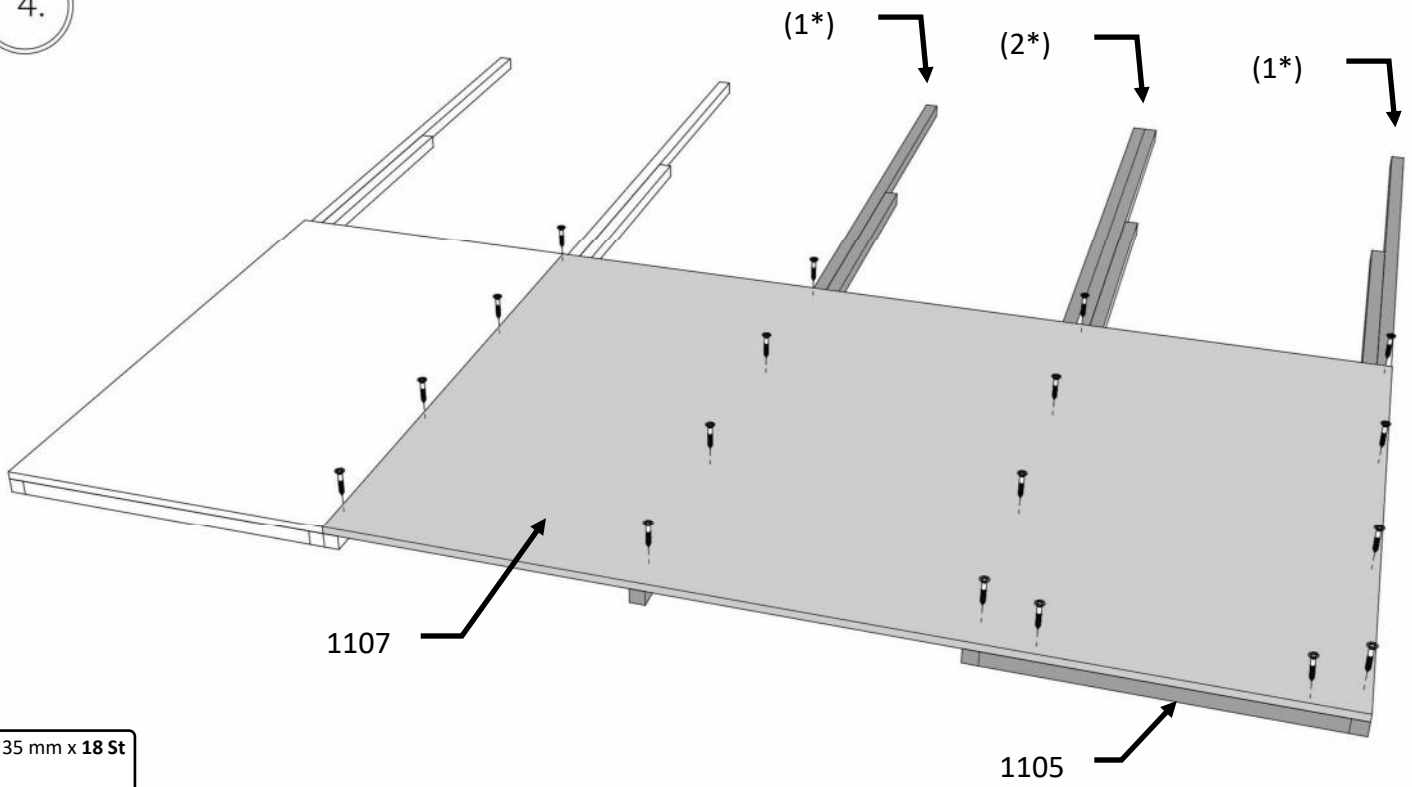

35 mm x 18 St



4.1



# WC201040

5.

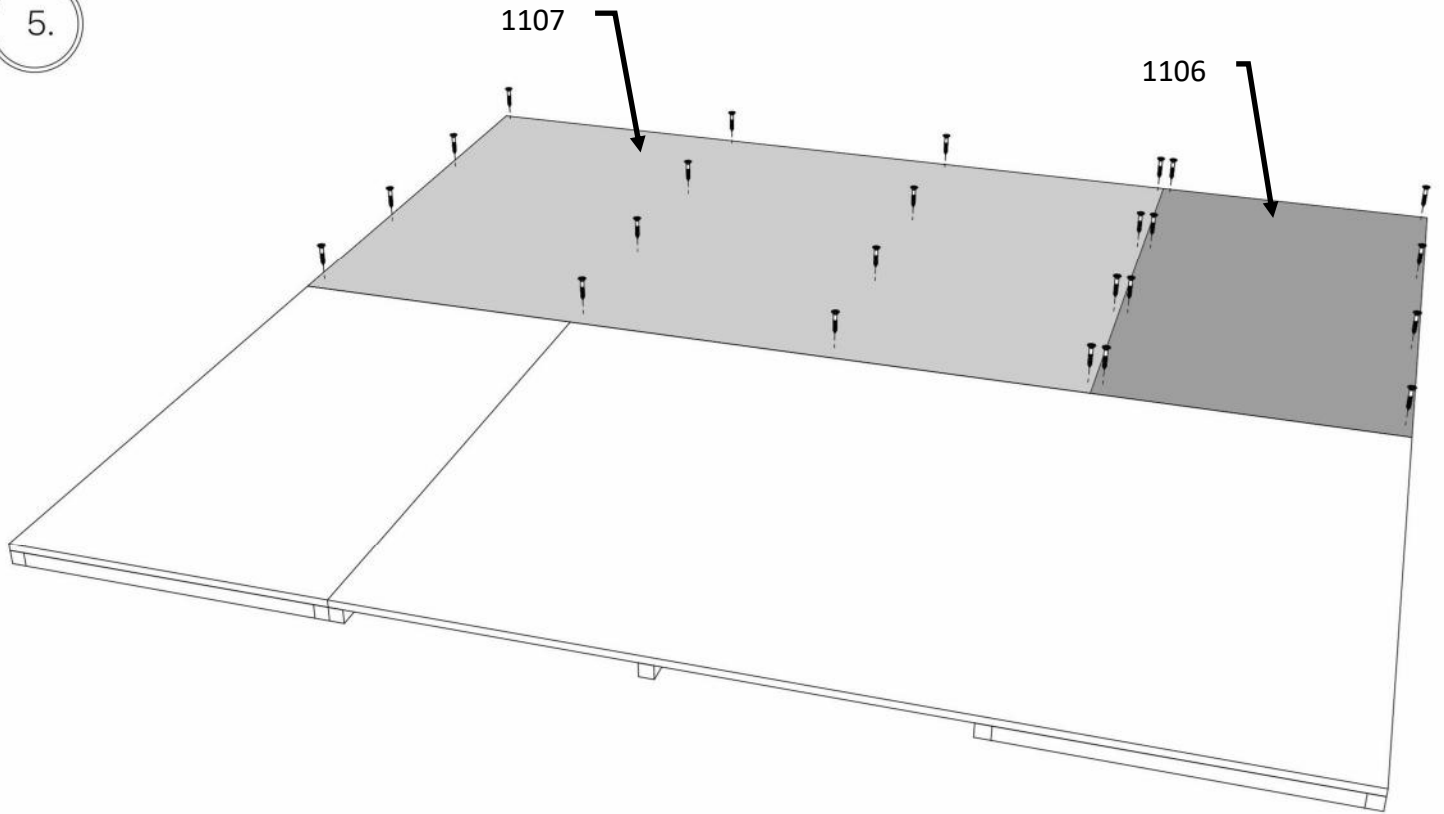

35 mm x 24 St



6.

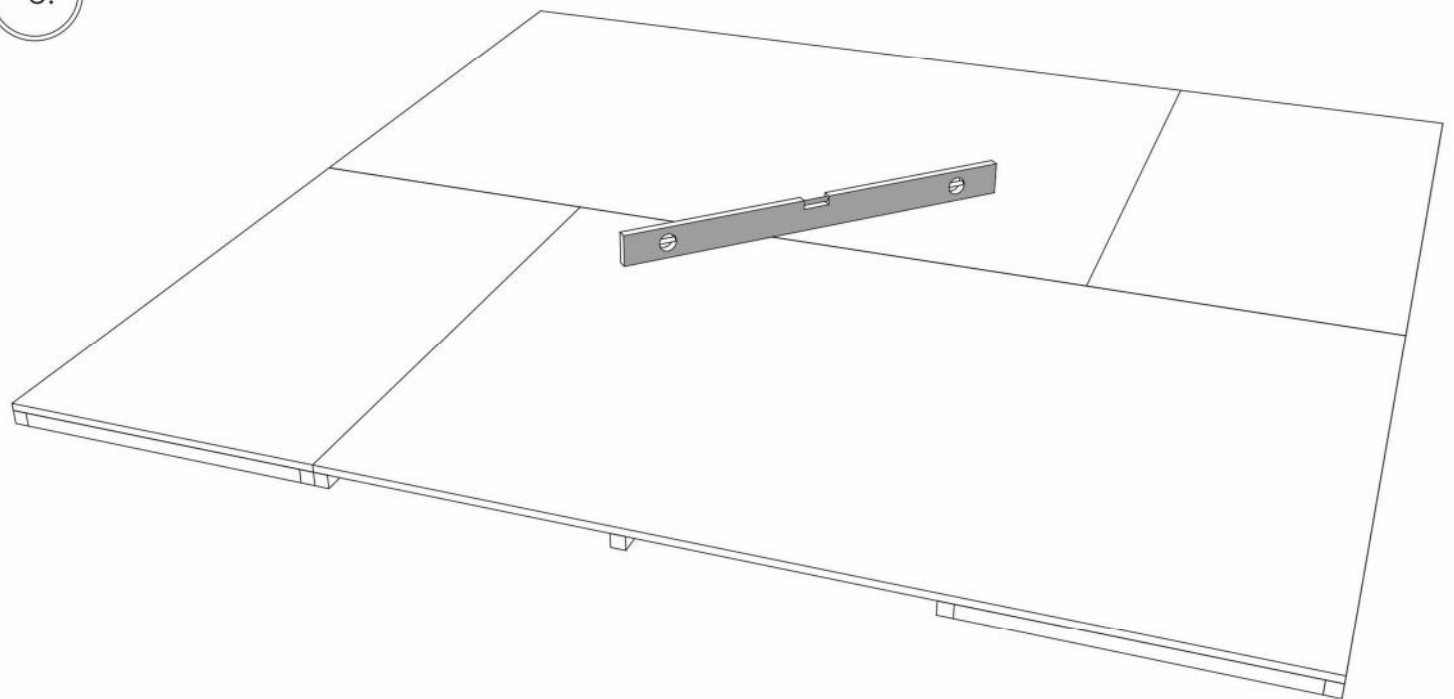

# WC201040

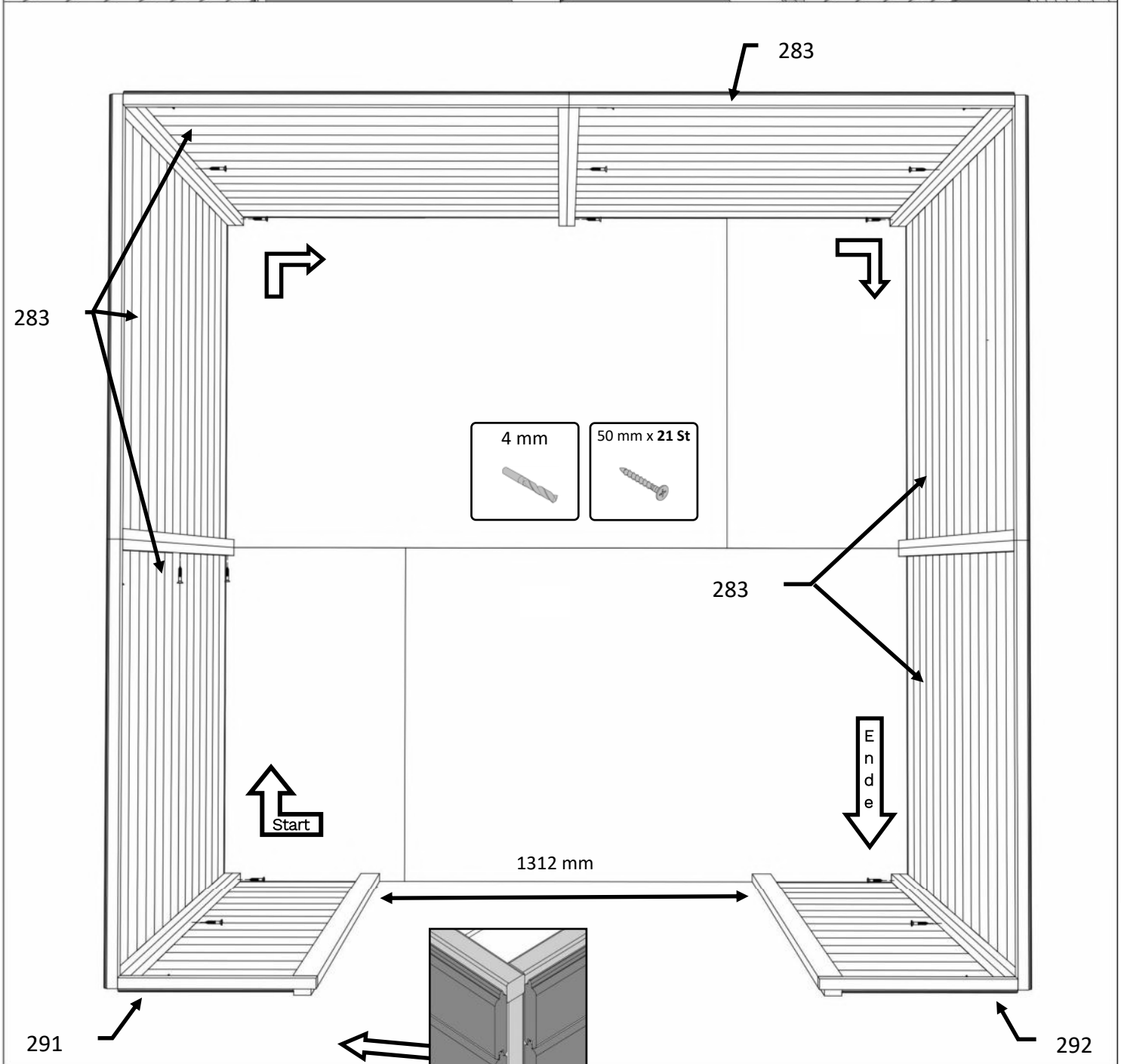
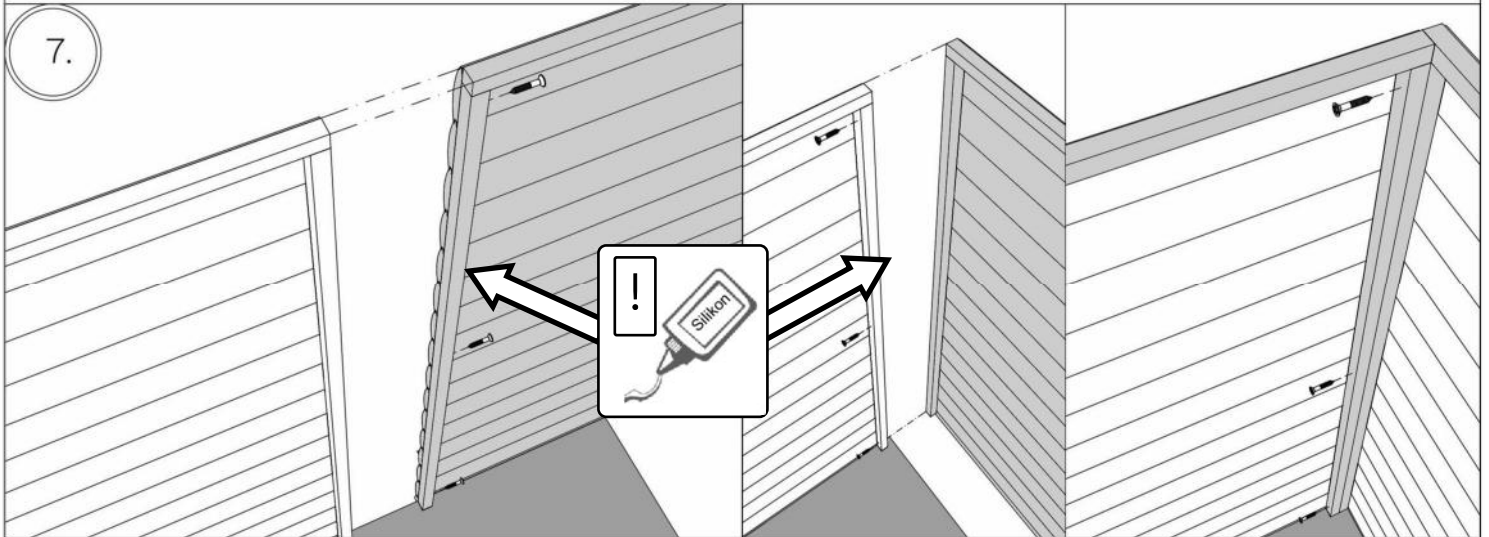



# WC201040

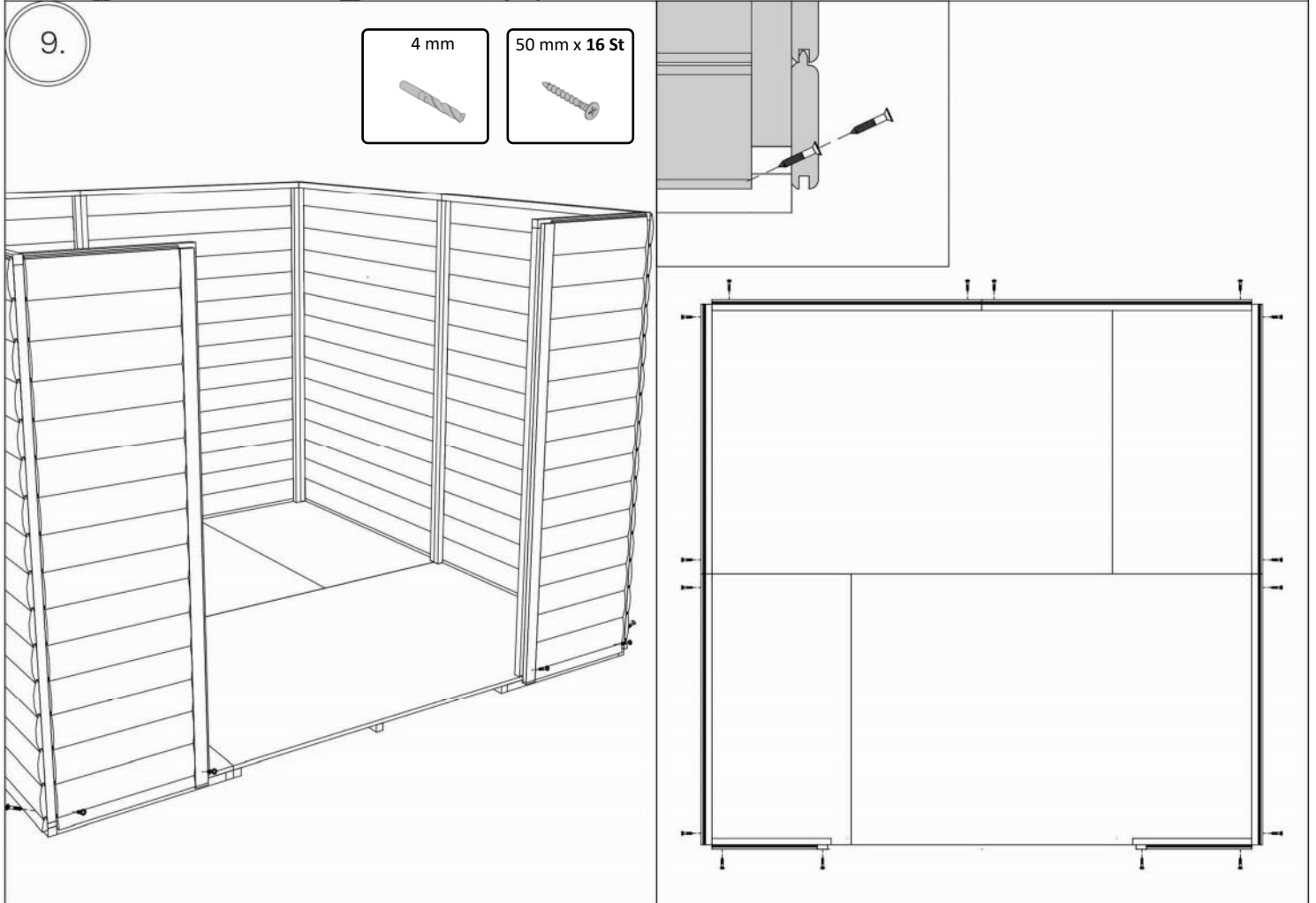
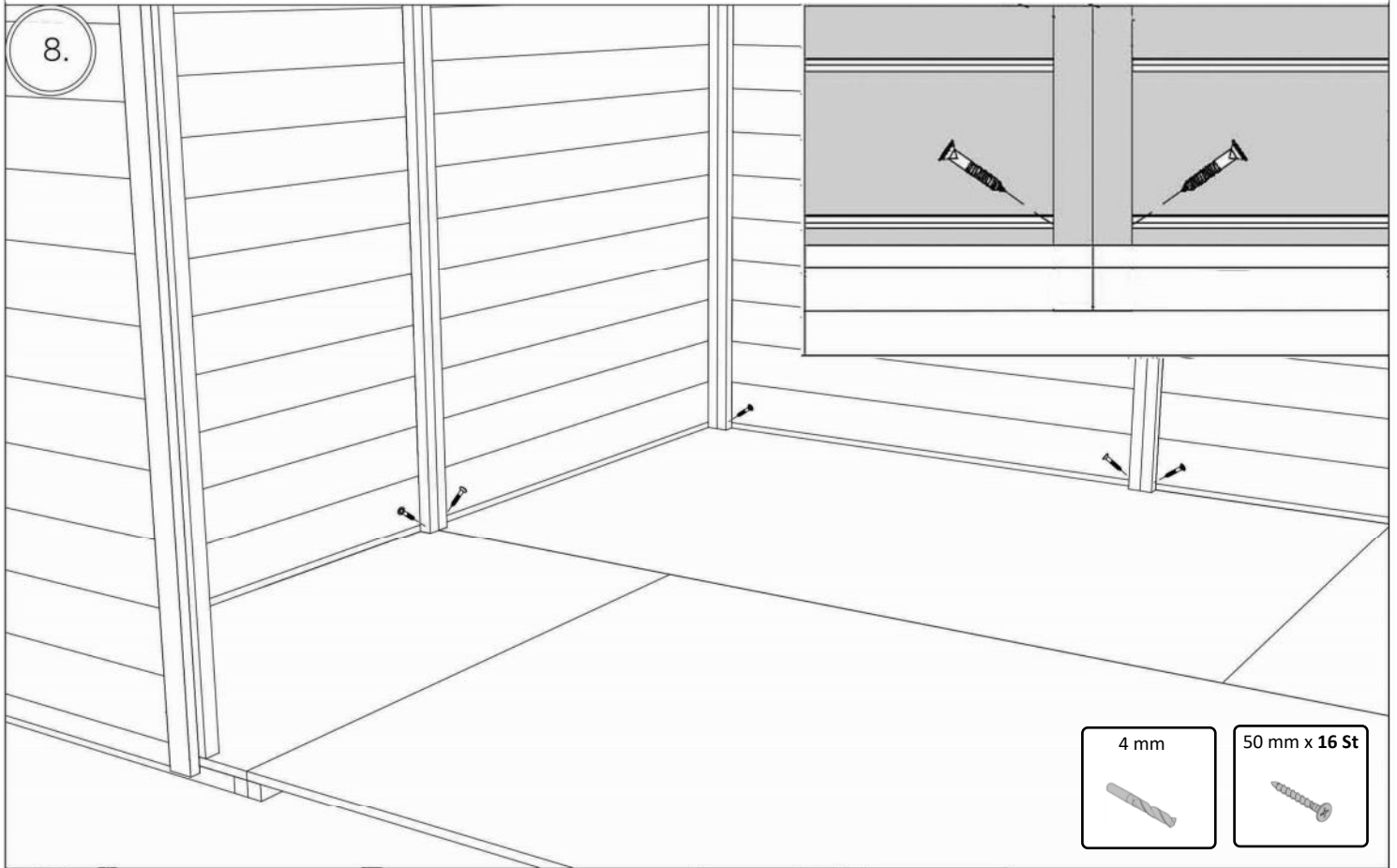

# WC201040

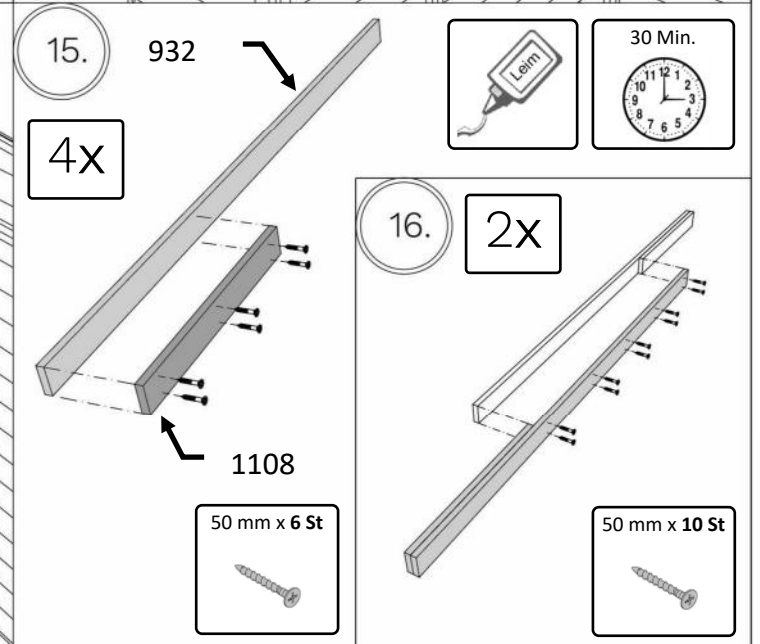
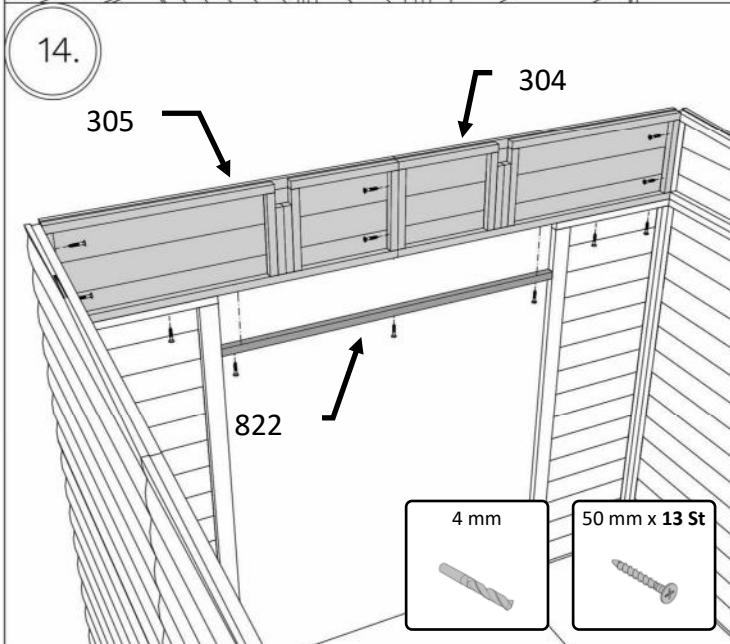
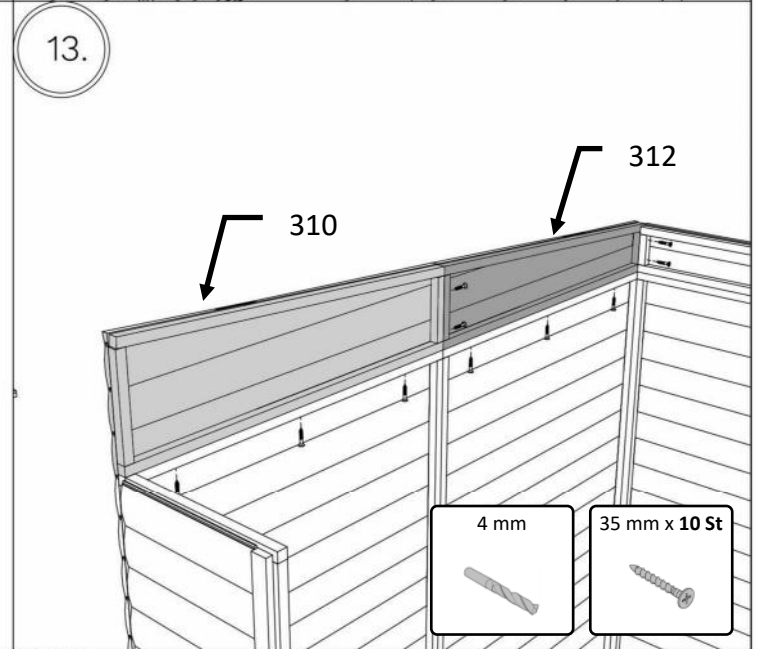
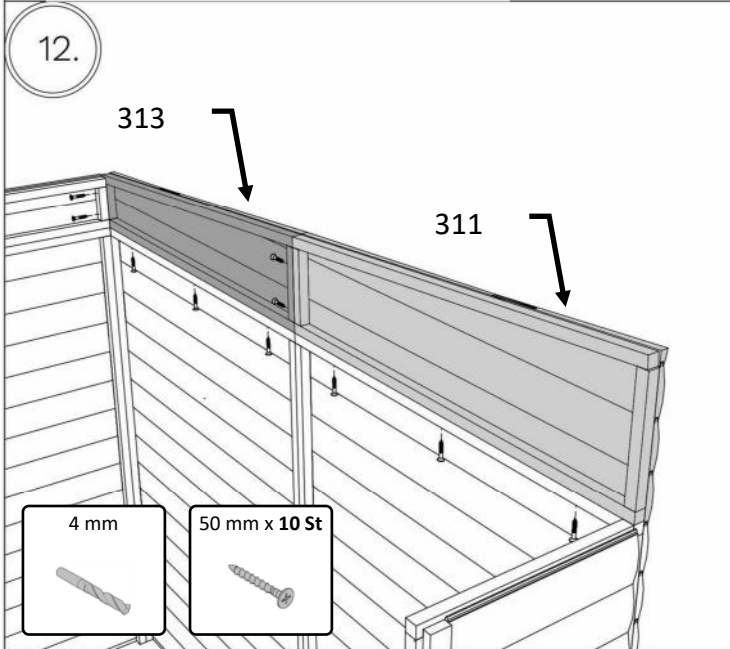
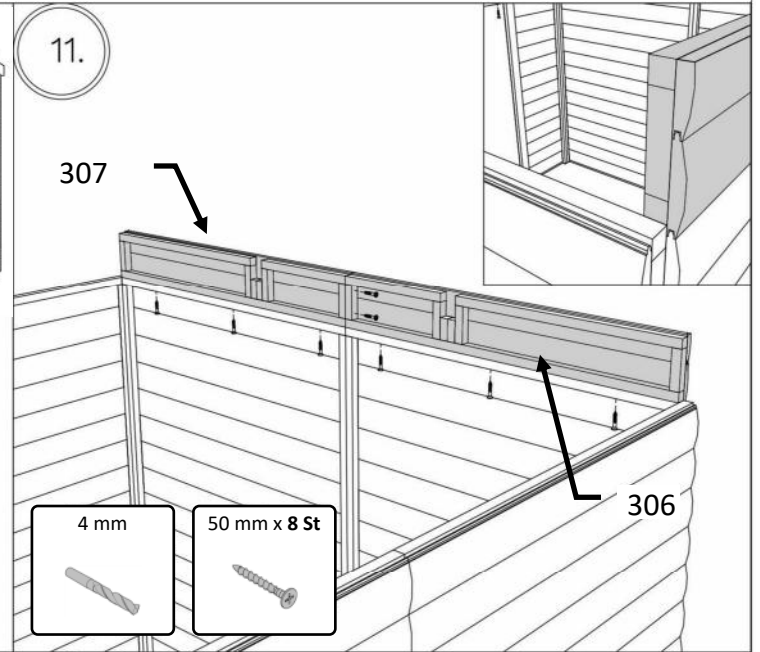
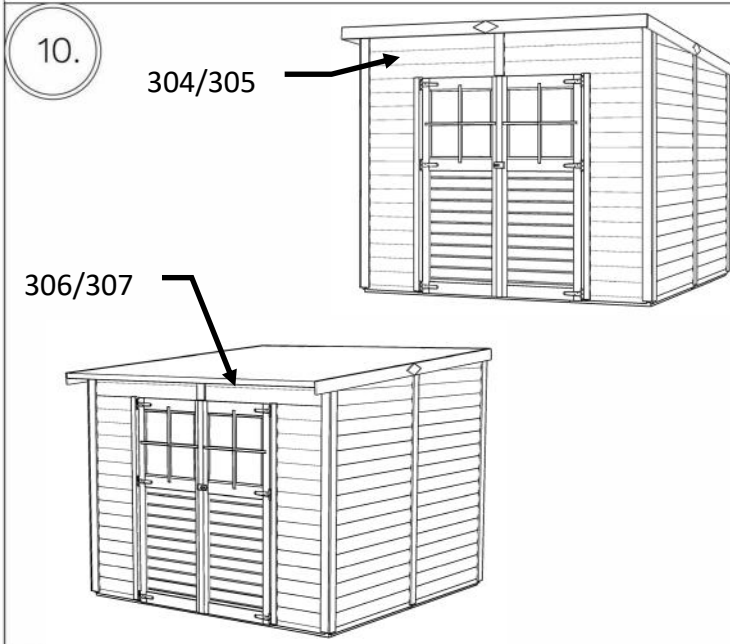

# WC201040

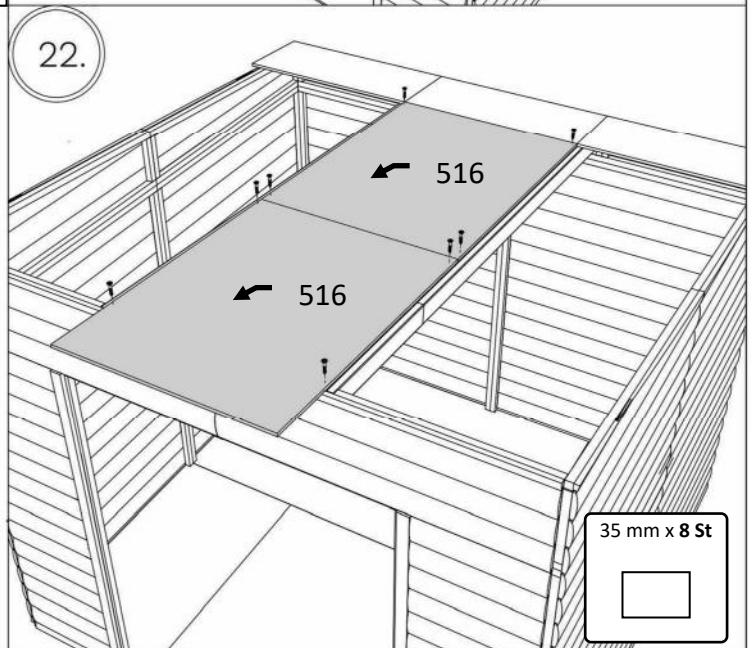
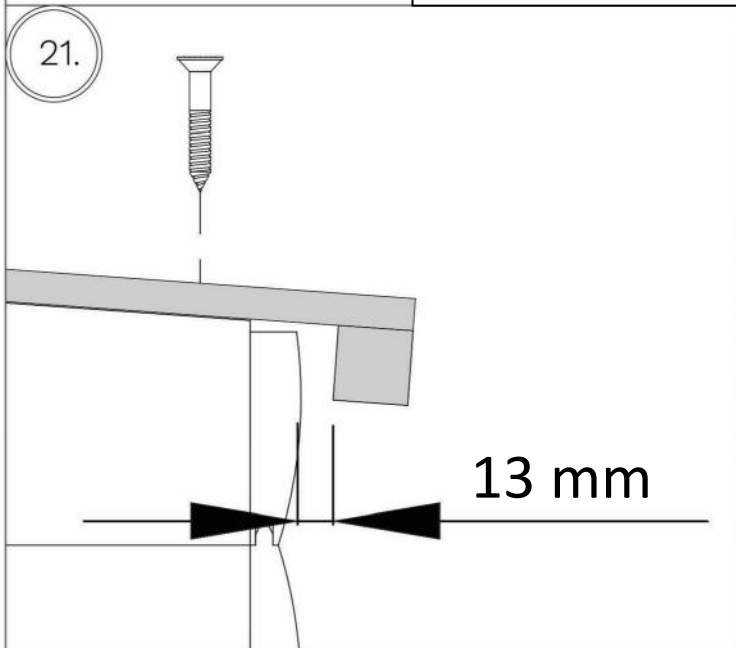
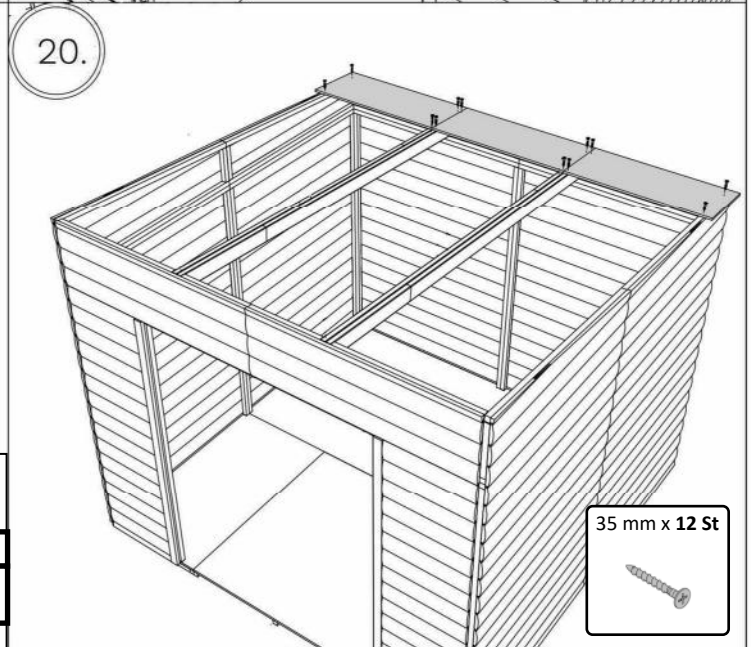
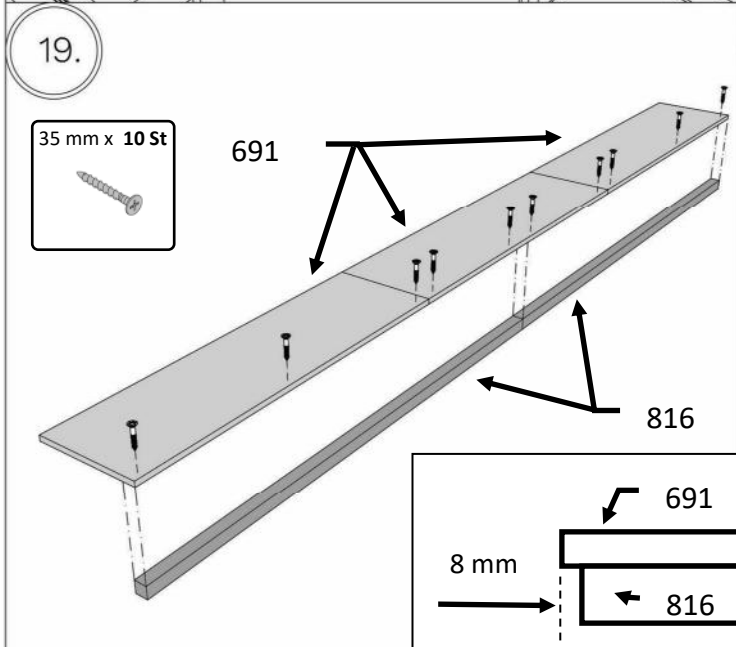
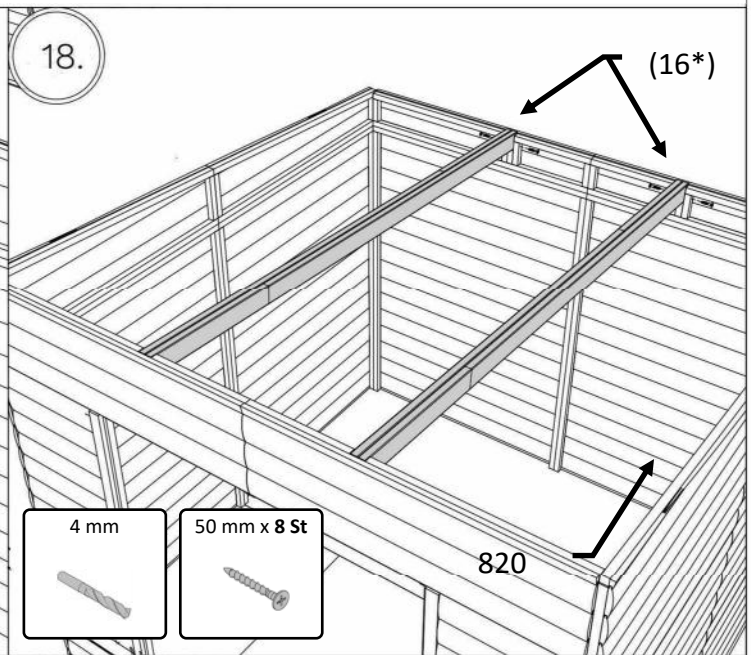
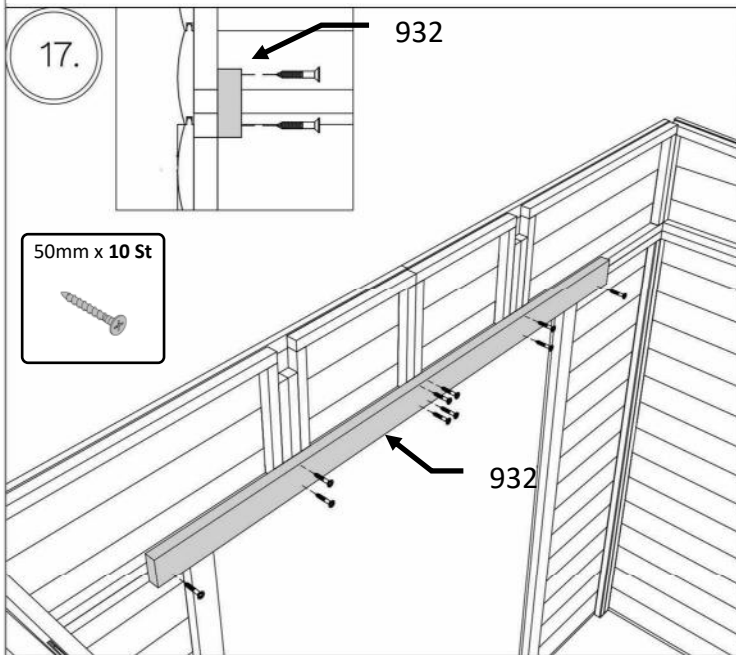

# WC201040

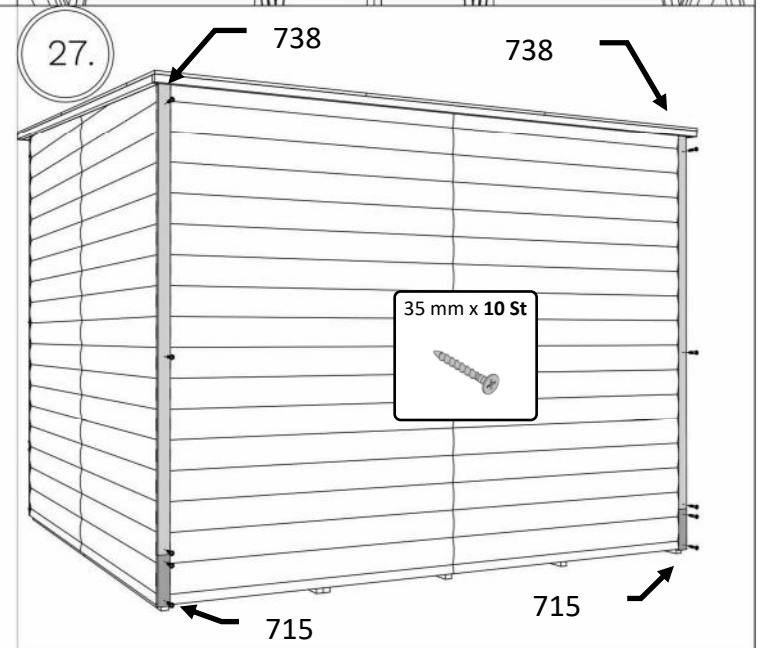
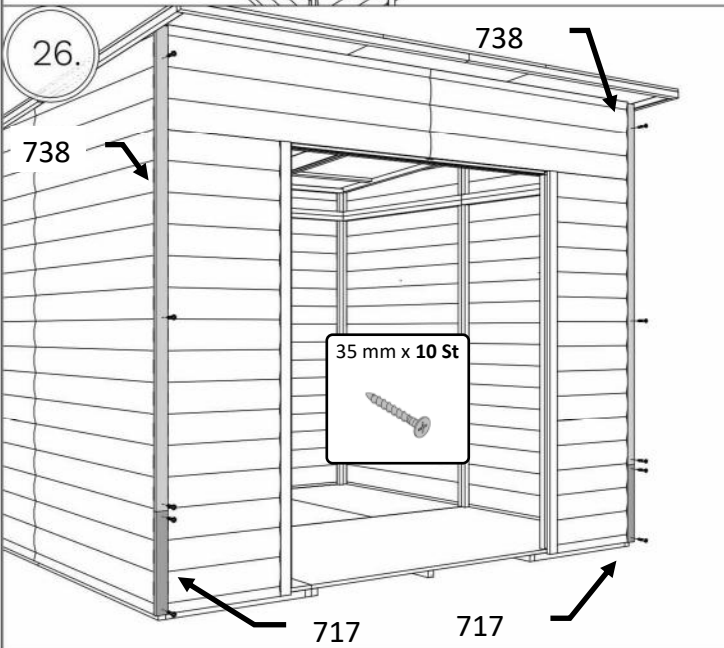
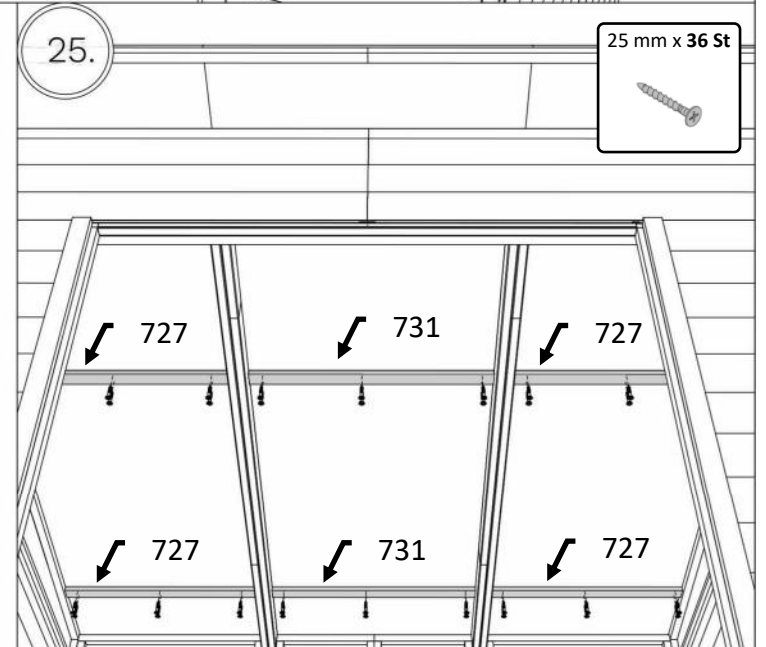
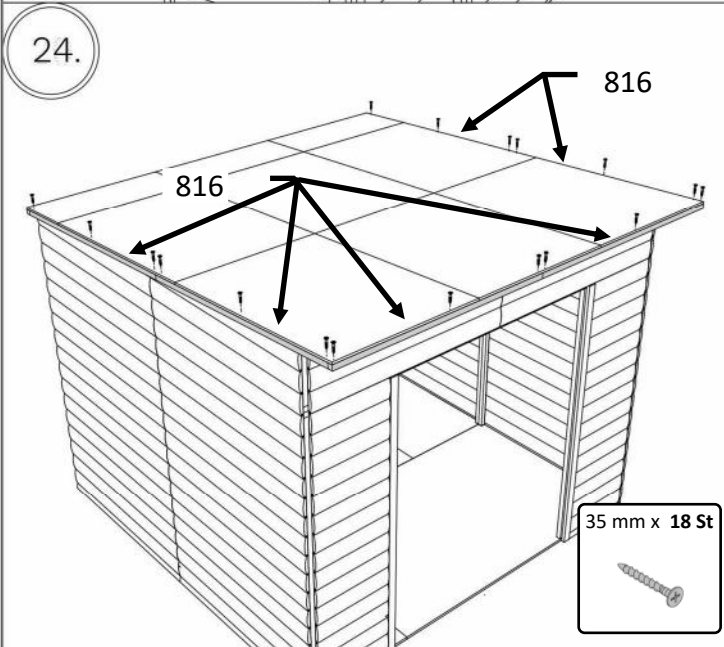
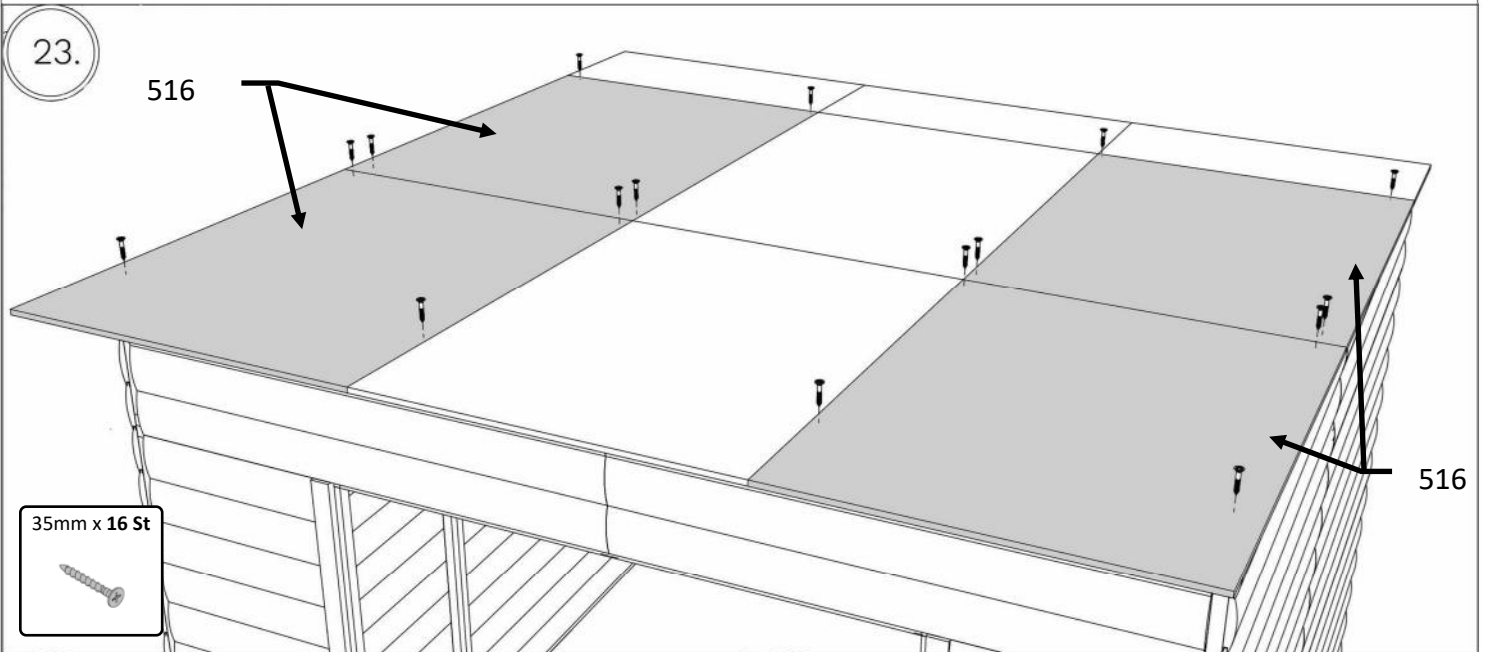

# WC201040

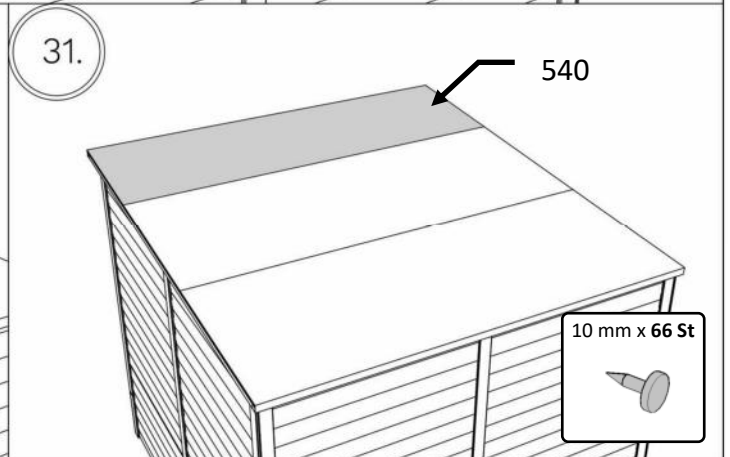
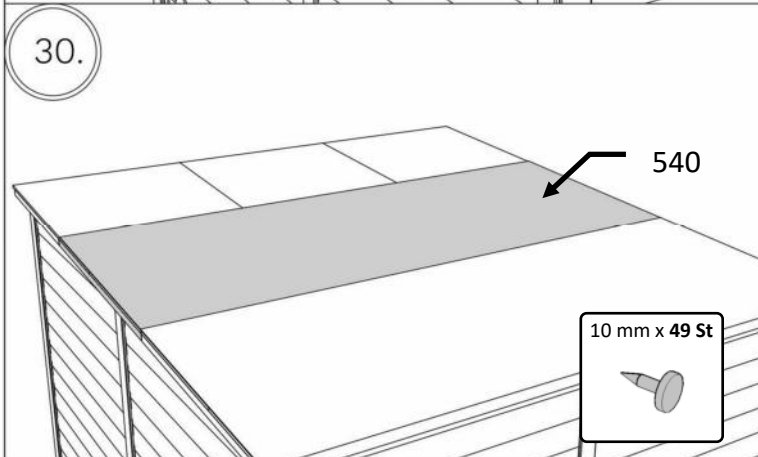
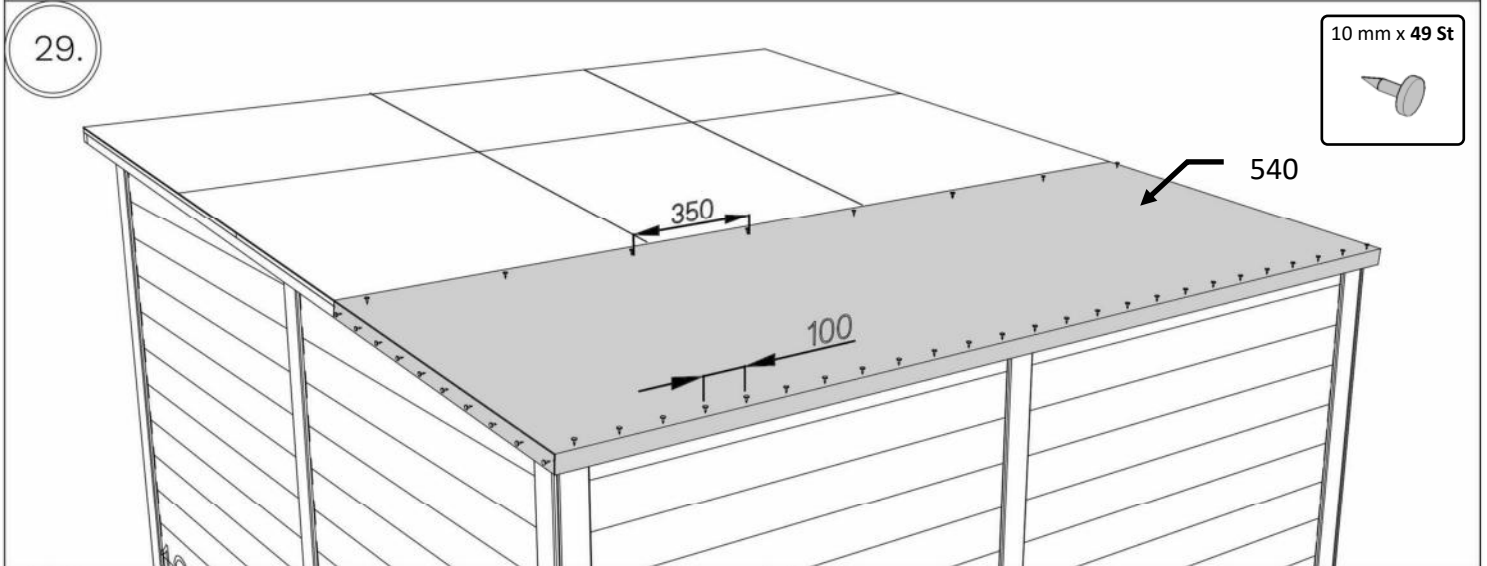
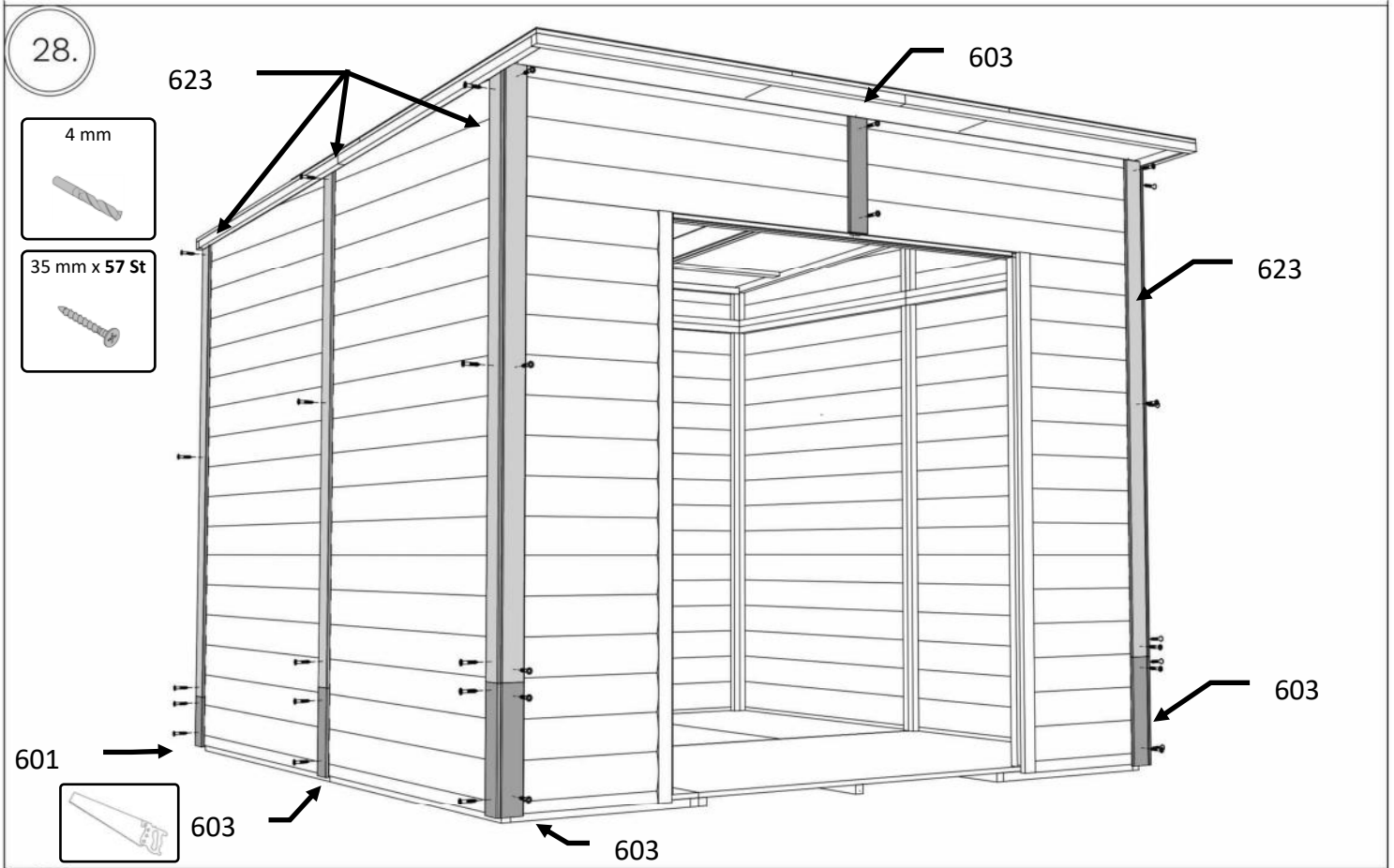

# WC201040

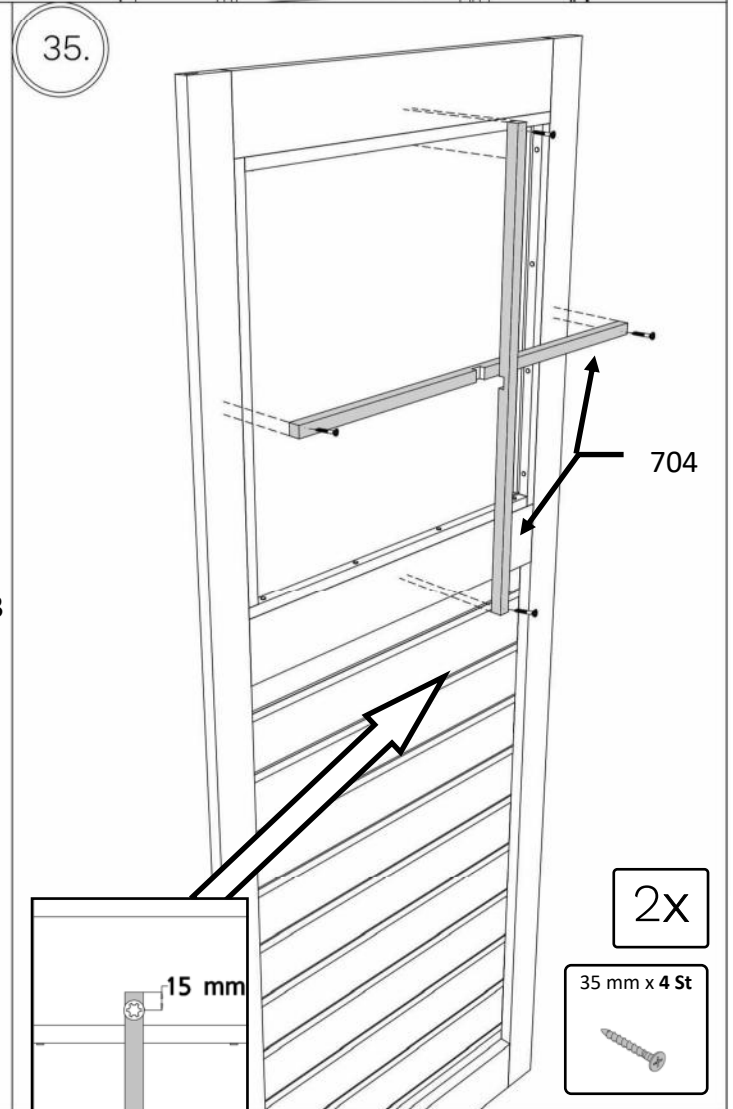
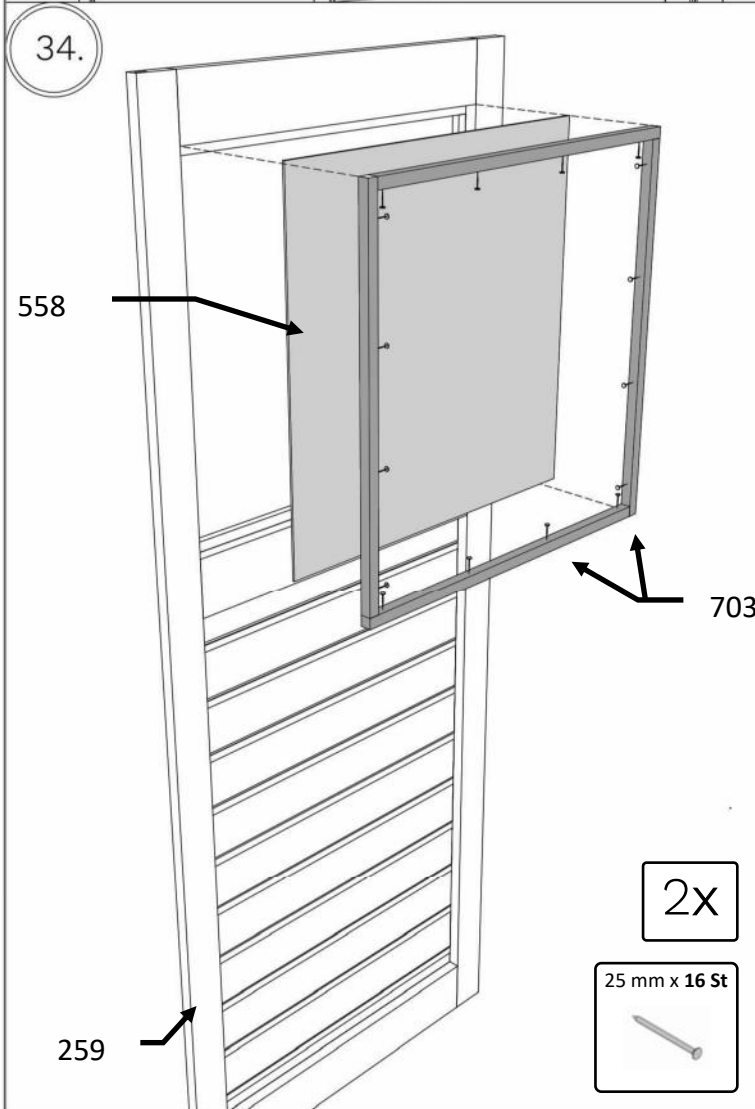
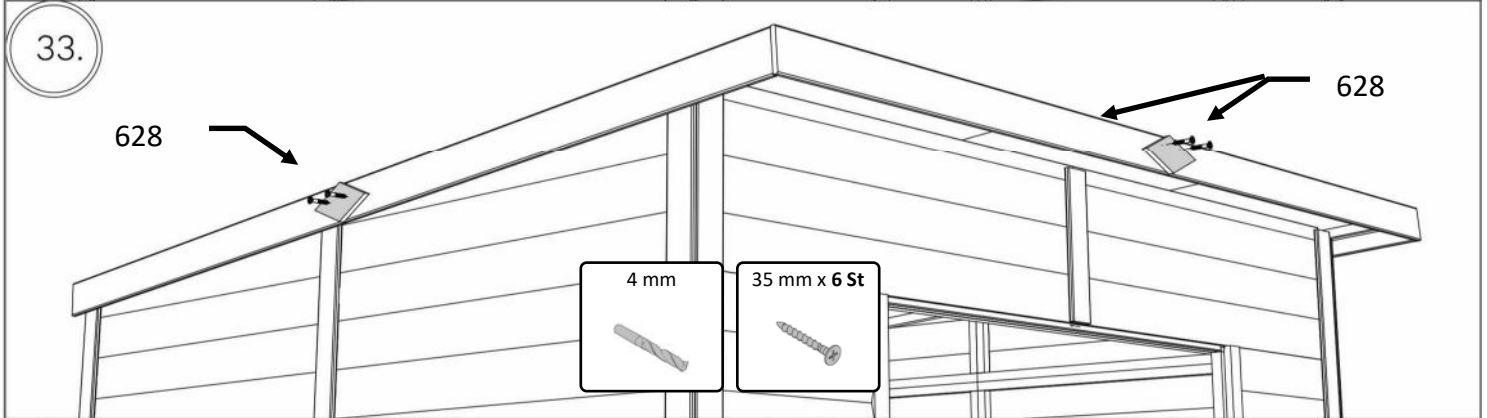
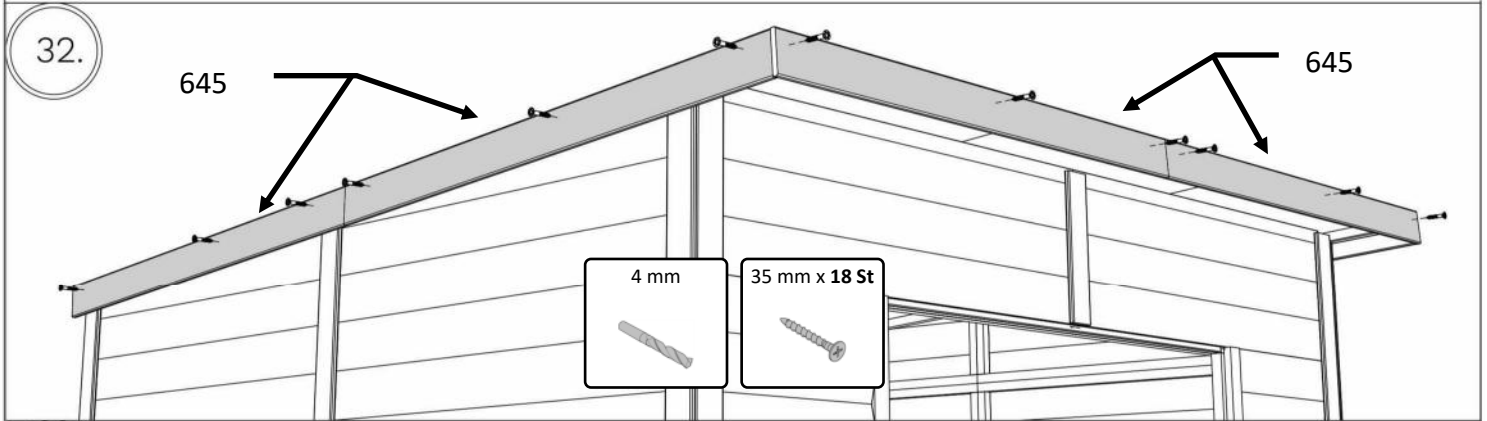

# WC201040

