

Assembly Manual / Guide d'assemblage / Manual de ensamblaje / Montageanleitung

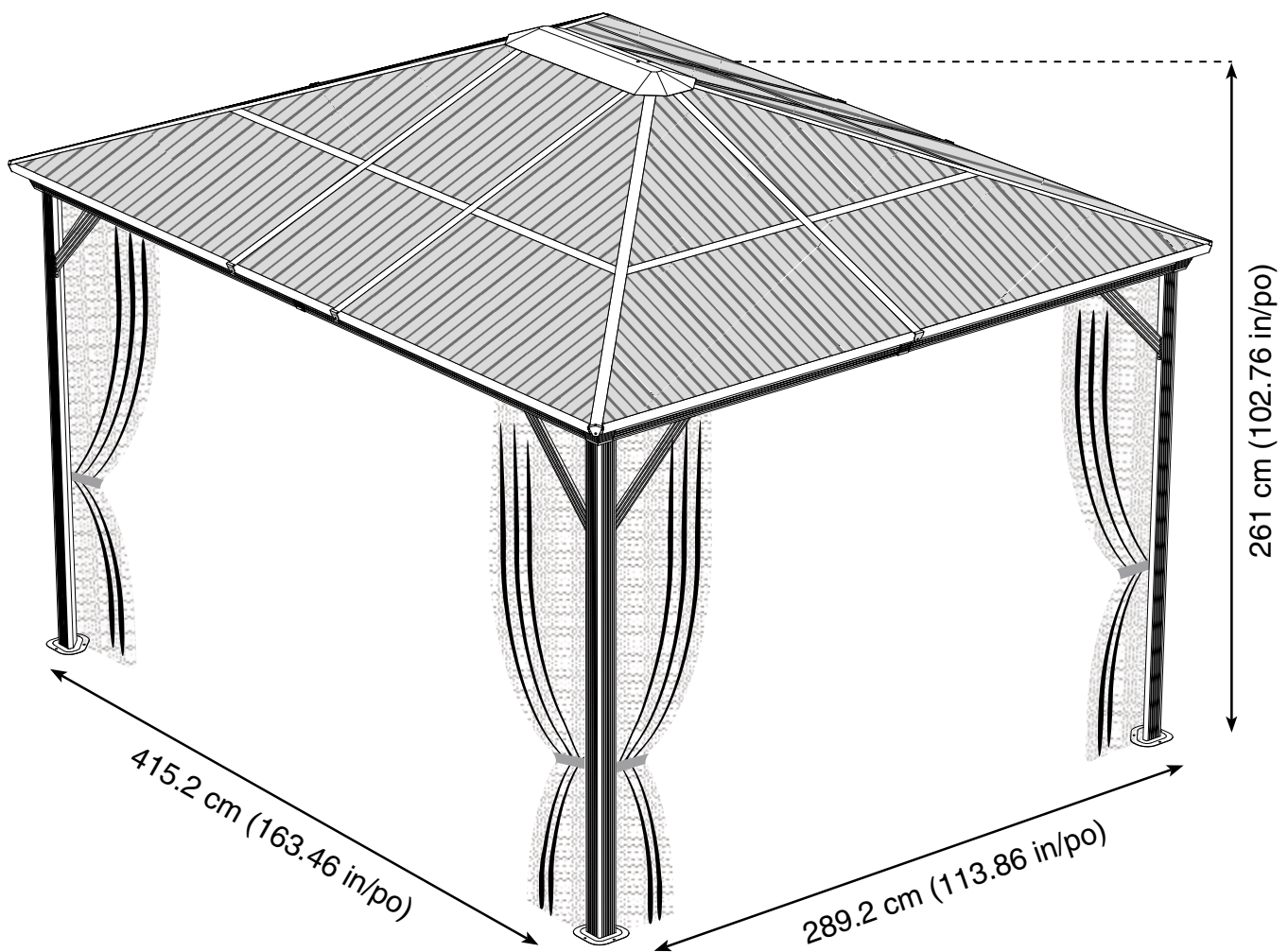

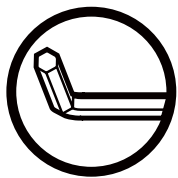

Use the hex keys in the box. / Utilisez les clés hexagonales fournies dans la boîte. / Utilice las llaves hexagonales en la caja. / Verwenden Sie die Sechskantschlüssel in der Box.

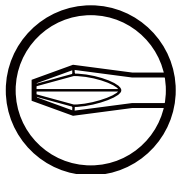

Please use a Phillips screwdriver. / Utilisez un tournevis de type Phillips / Por favor, use un destornillador Phillips. / Bitte verwenden Sie einen Kreuzschraubenzieher.



You may need to use a drill for this step. / Vous pouvez avoir besoin d'utiliser une perceuse pour cette étape. / Puede que tenga que utilizar un taladro para este paso. / Für diesen Schritt können Sie einen Bohrer verwenden.



Wearing protective gloves is recommended. / Le port de gants de protection est recommandé / El uso de guantes de protección se recomienda. / Das Tragen von Schutzhandschuhen wird empfohlen.



Two or more people are required at this stage. / Deux personnes ou plus sont nécessaires à cette étape. / Dos o más personas se requieren en esta etapa. / Für diesen Bauschritt sind 2 oder mehr Personen erforderlich.



Do not tighten screws all the way for now. / Ne pas visser fermement pour l'instant. / No atornille con firmeza por ahora. / Bitte die Schrauben zum jetzigen Zeitpunkt noch nicht fest anziehen.

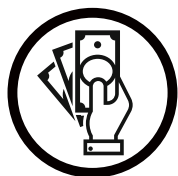

Sold separately. / Vendus séparément. / vendido en las opciones. / Optional erhältlich



Optional step / Étape optionnelle / Paso opcional / Optionaler Schritt

T X 8 (+2)

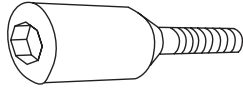

U X 16 (+2)

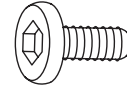

U1 X 1 (+1)

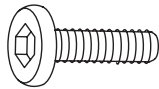

U2 X 2 (+1)



V X 72 (+7)

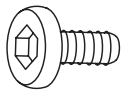

V1 X 16 (+2)

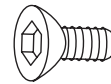

V2 X 20 (+2)

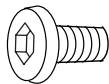

W X 24 (+4)

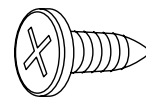



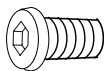



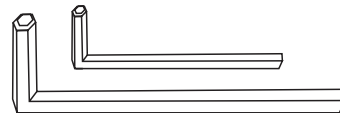

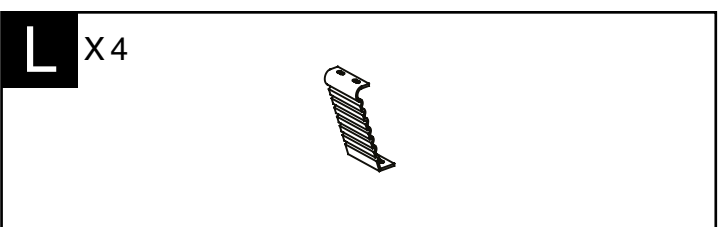
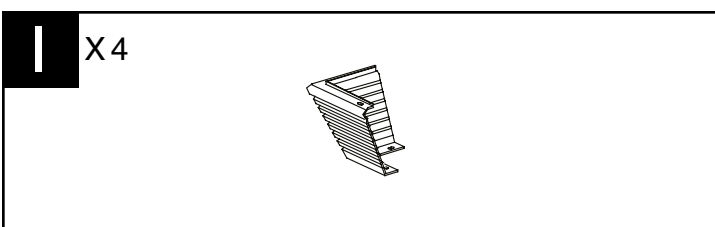
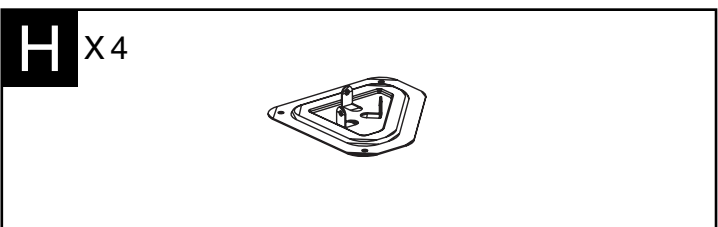
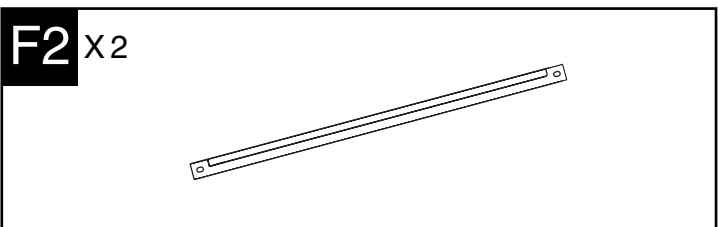
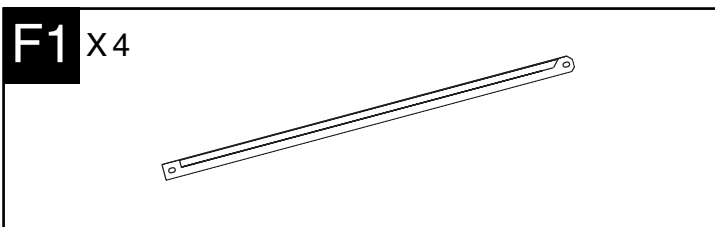
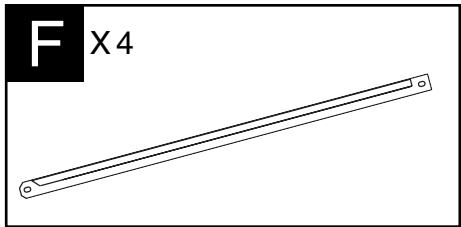
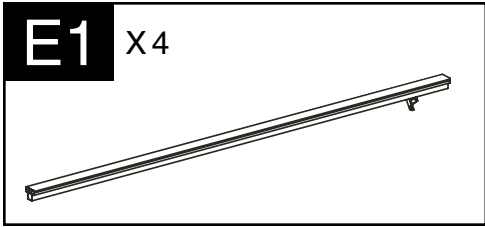
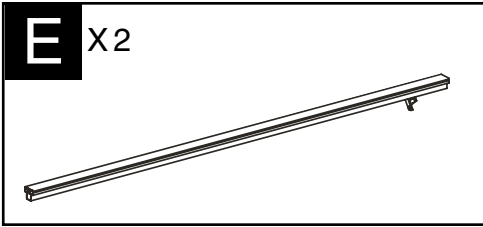
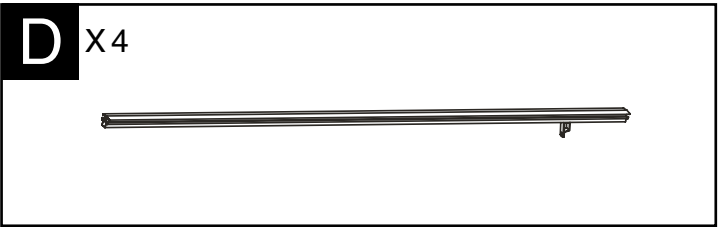
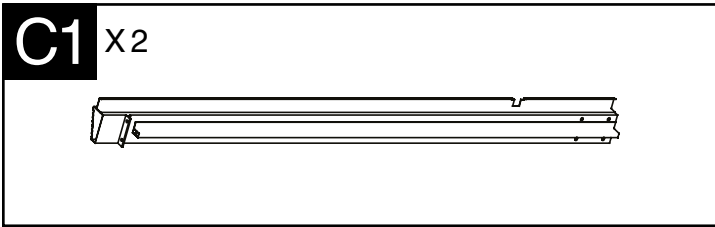
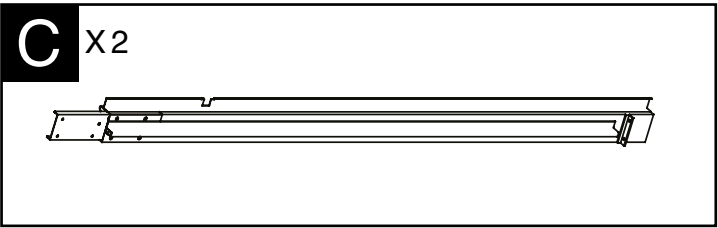
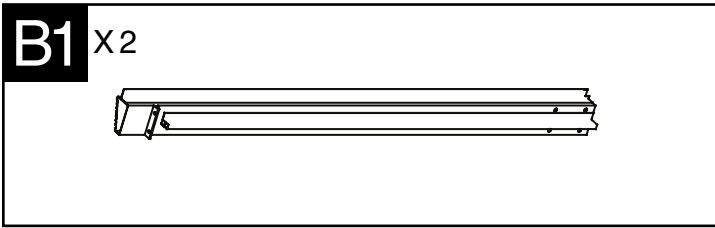
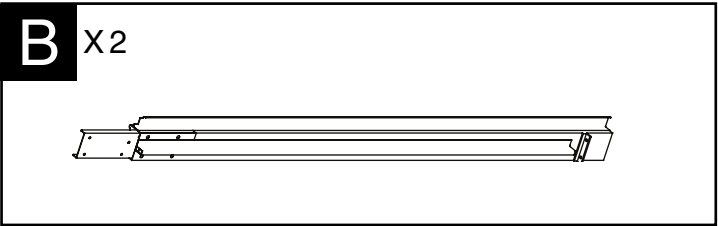

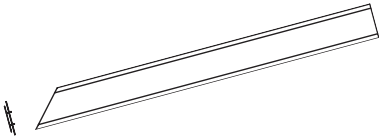
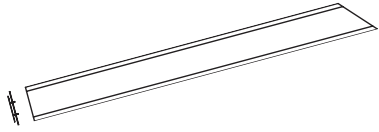
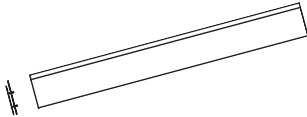
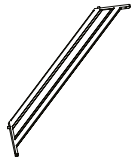
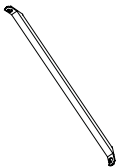

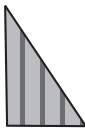
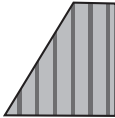
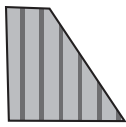
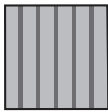

W1 X 16 (+2)

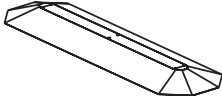
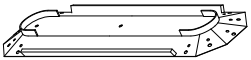

Y X 1

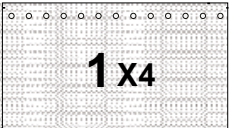

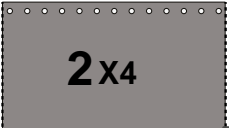

J X4 	J1 X4 	
J2 X2 	K X8 	
K2 X4 	Ma X4 	
Na X4 	Mb X4 	
Nb X4 	Z X2 	Z1 X2 
Q X4 	R X6 	S X1 
S1 X1 	X X 56(+2) optional   	
Net  1 X4  optional	Curtain  2 X4  optional	

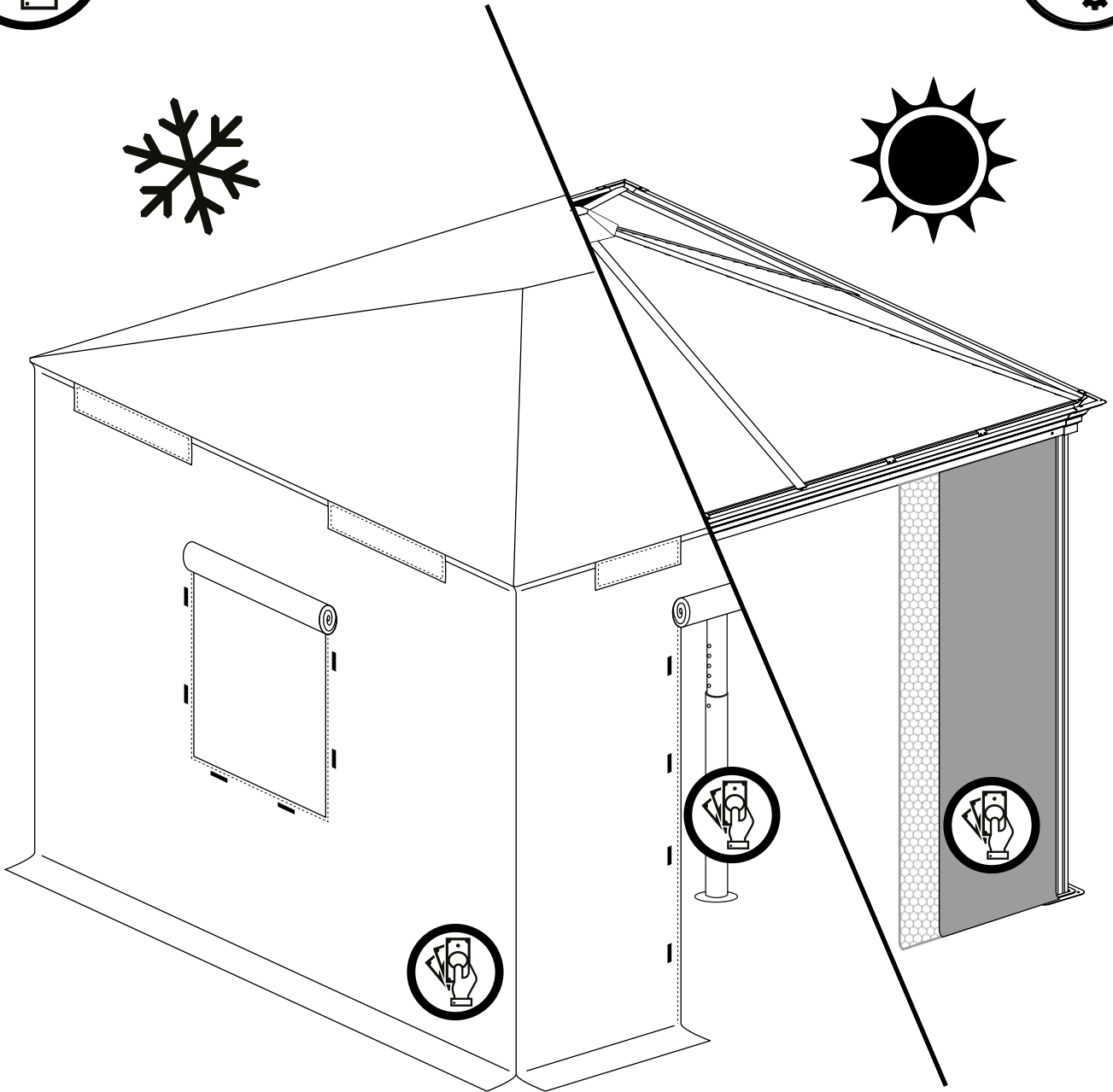
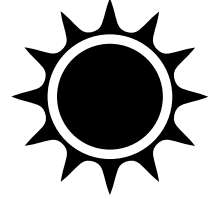
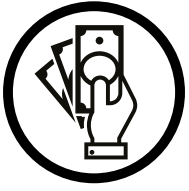

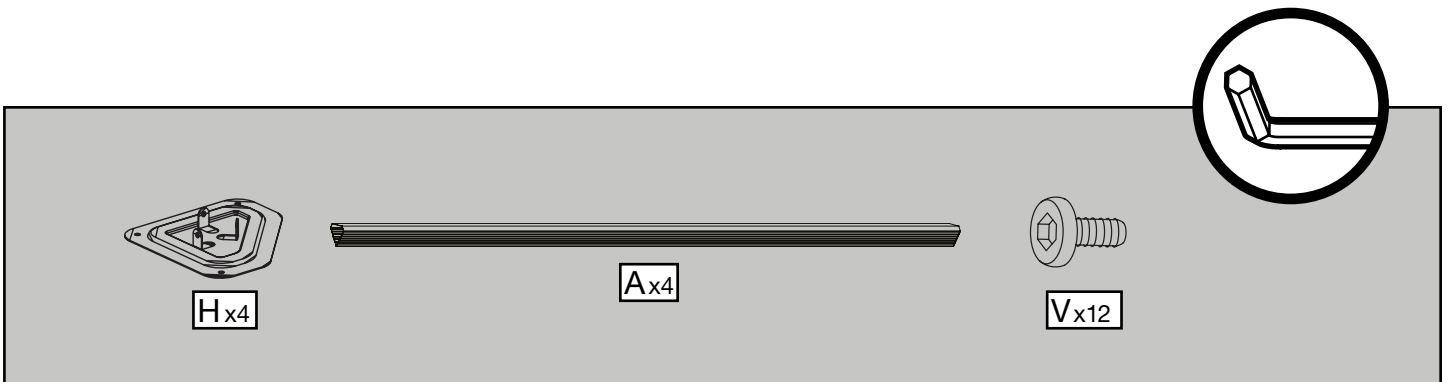
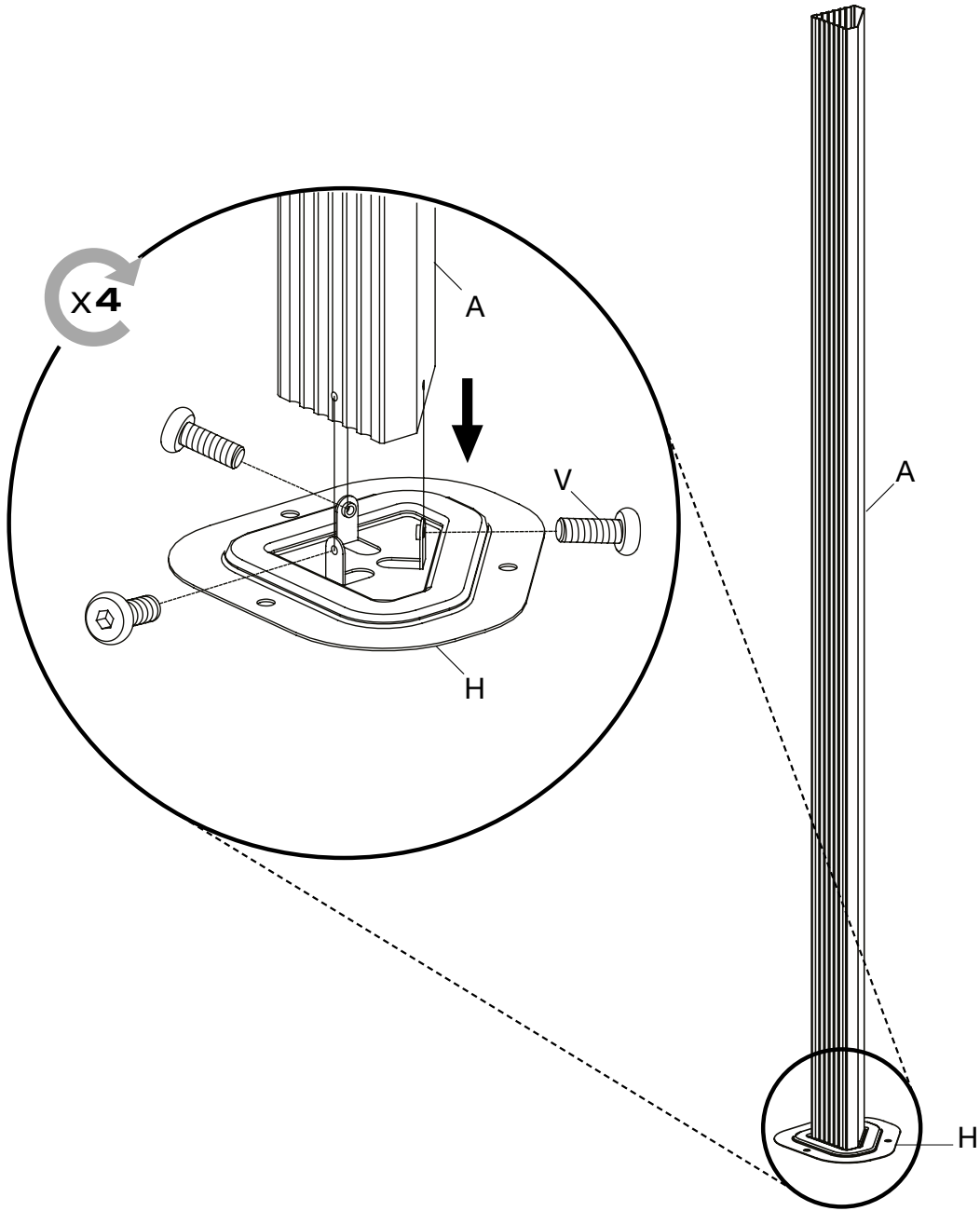

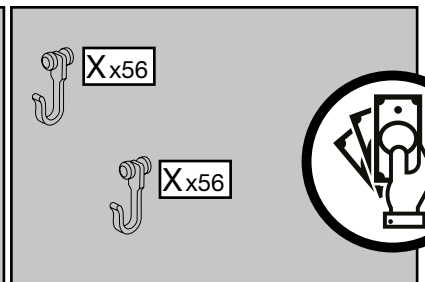
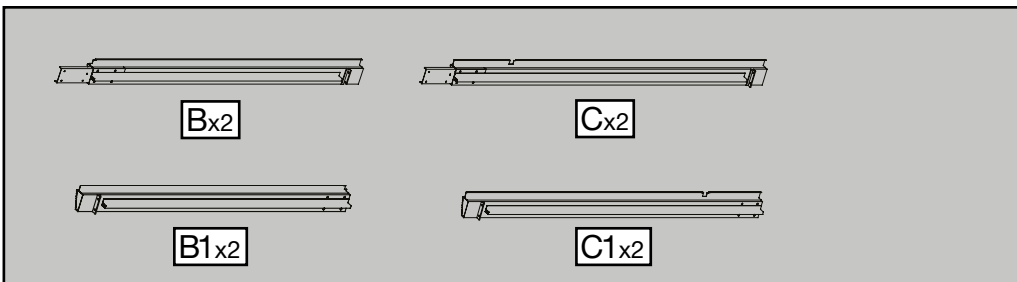
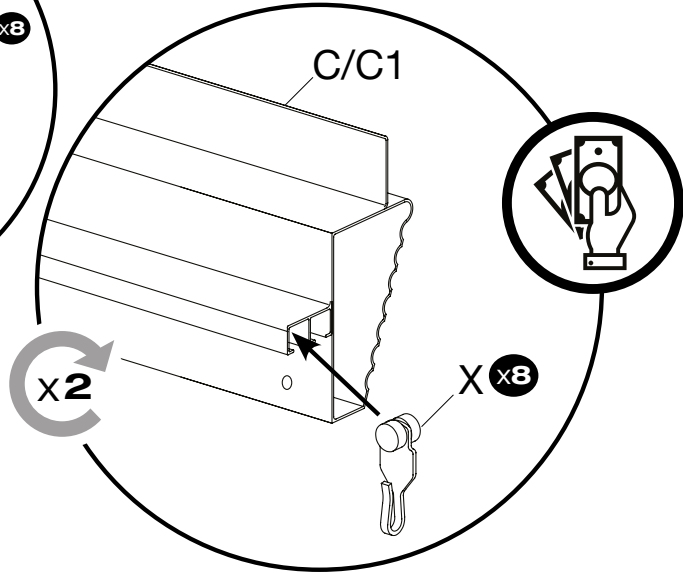
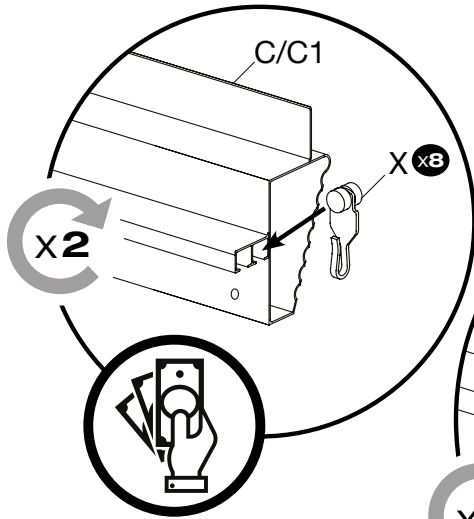
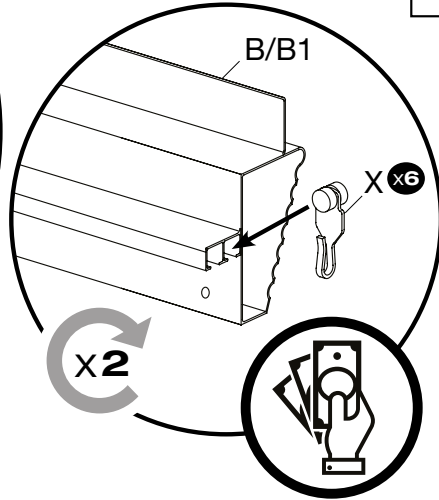
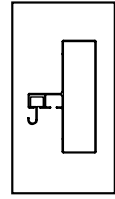
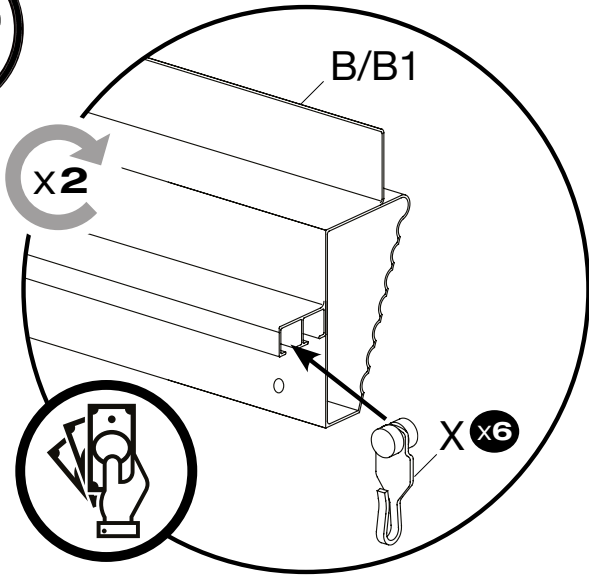

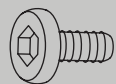
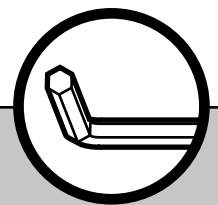
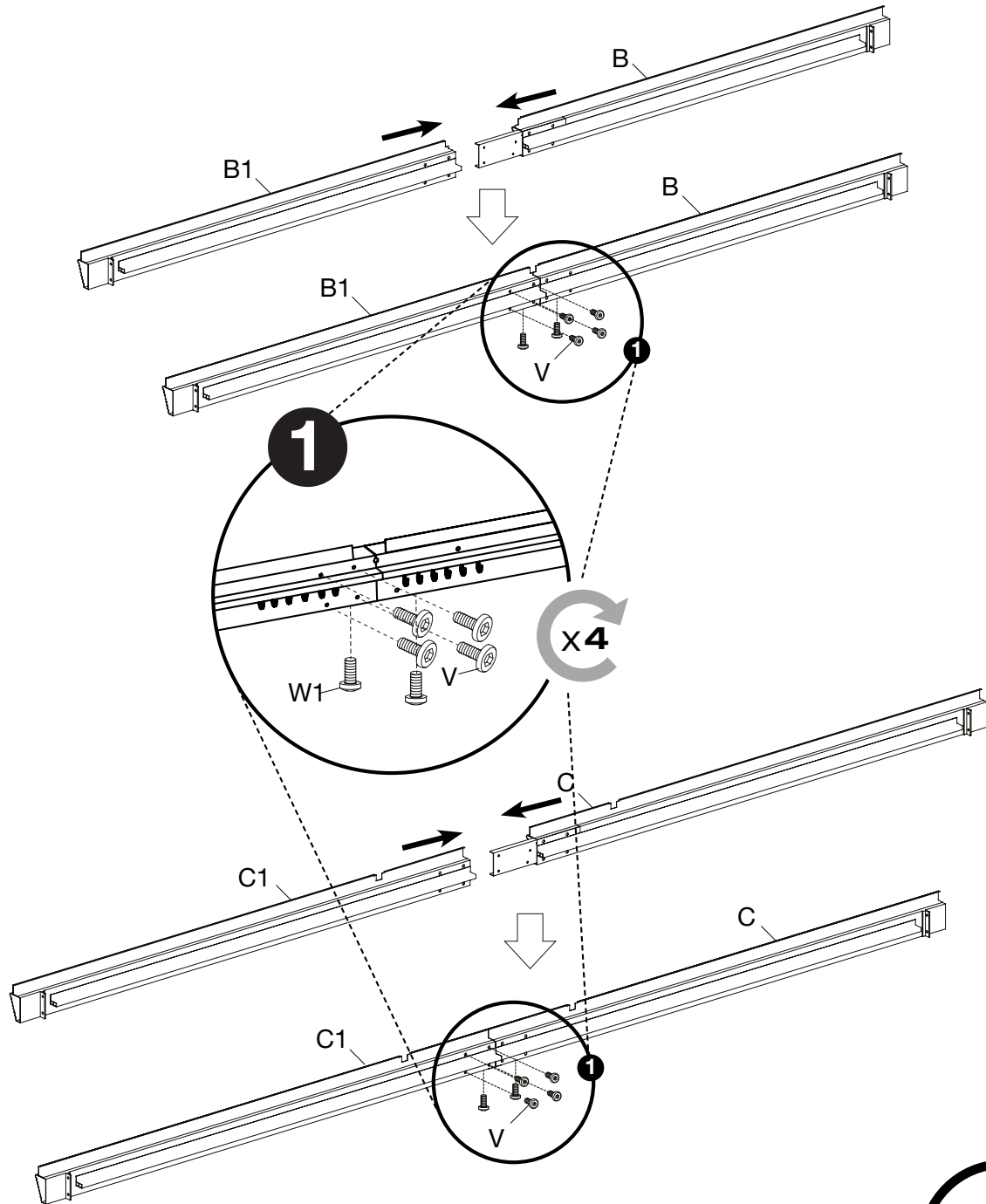

Vx16



W1x8

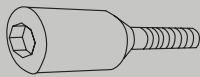
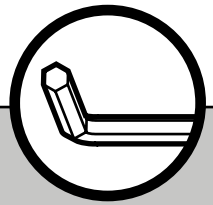
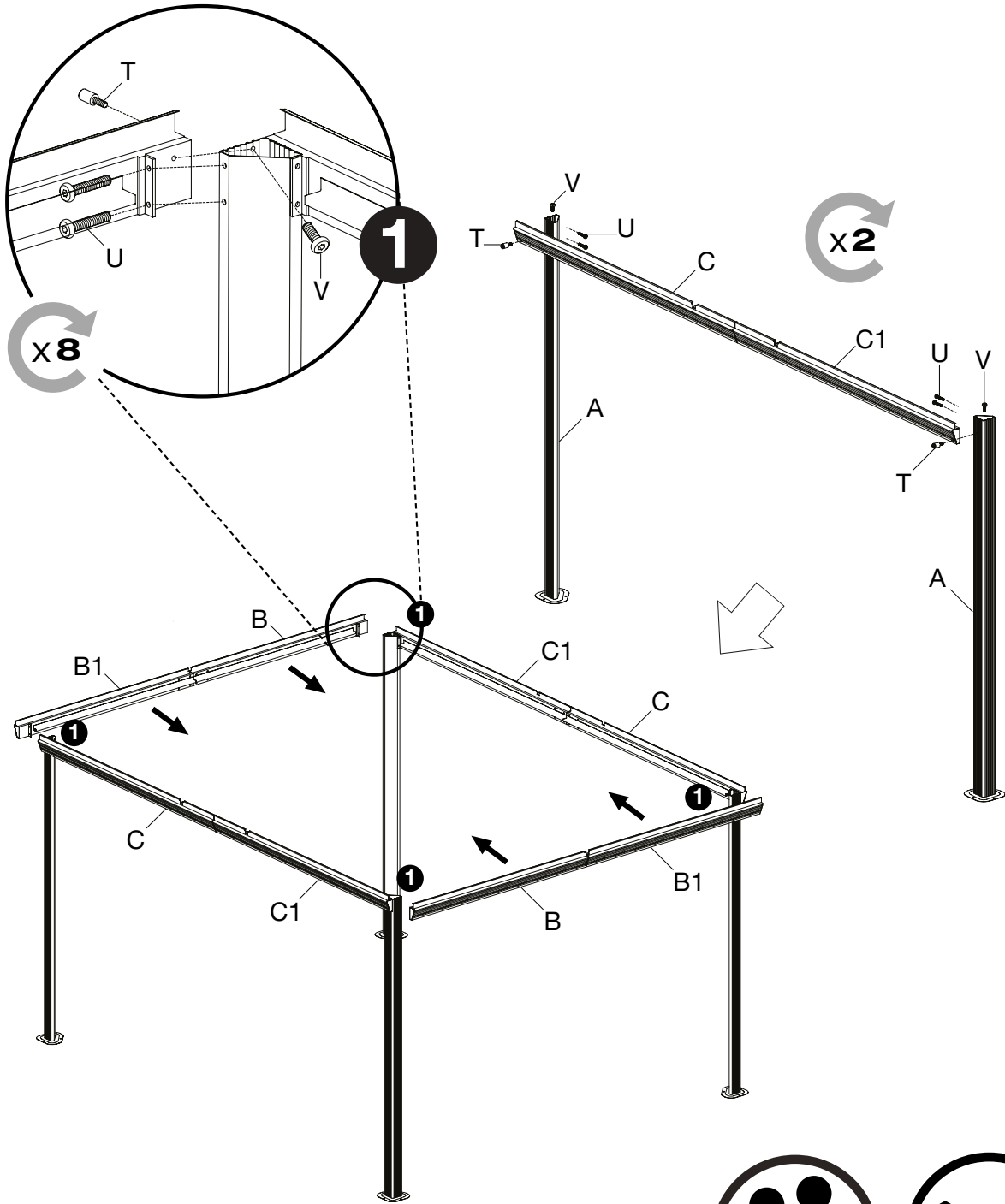

T x8

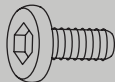

U x16

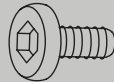

V x8

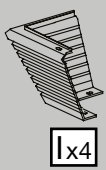
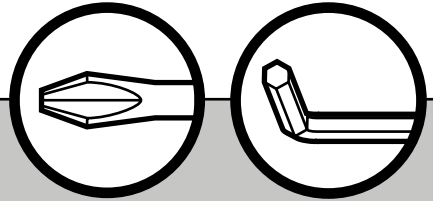
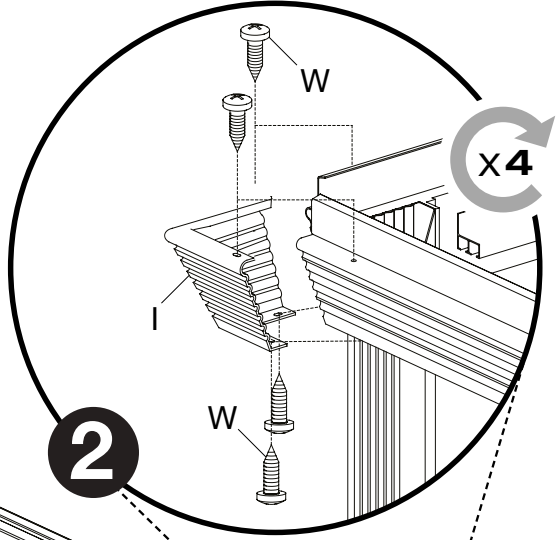
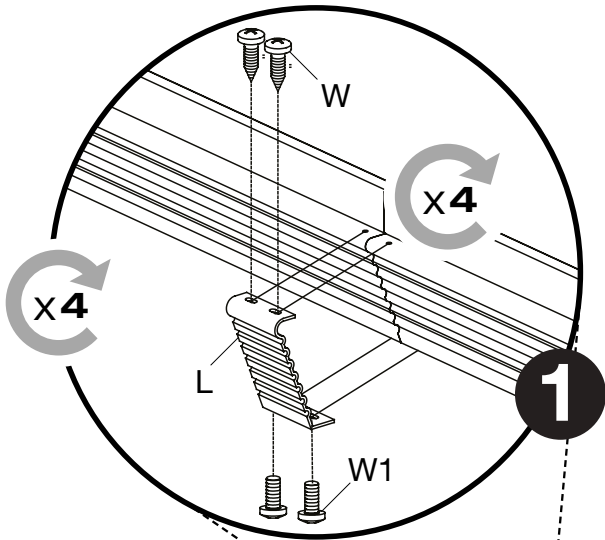
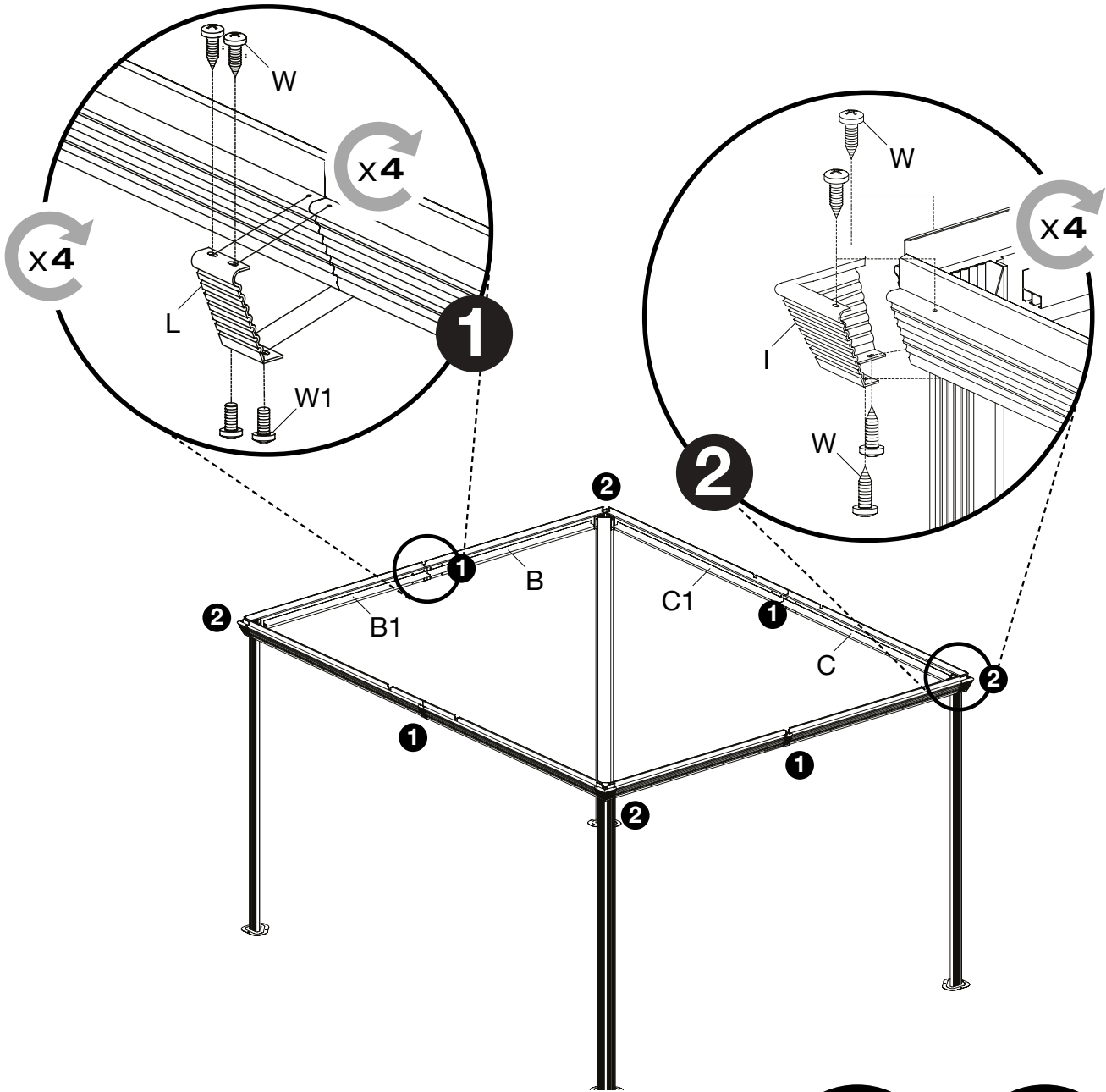

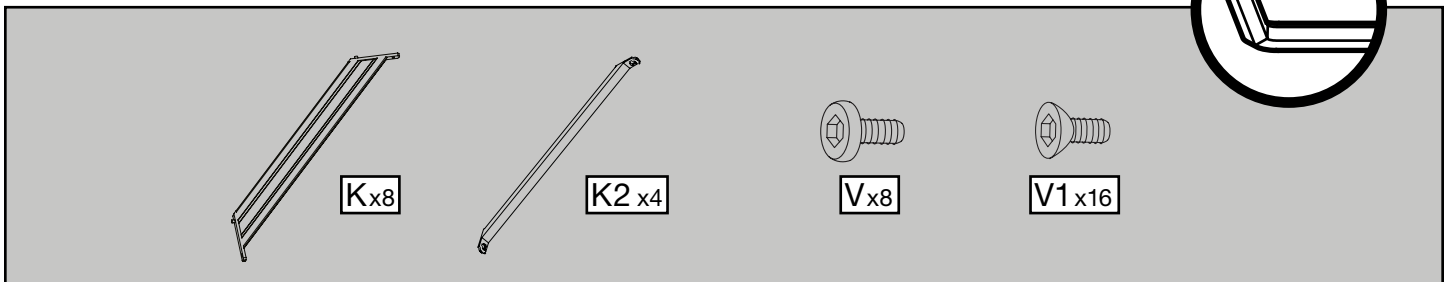
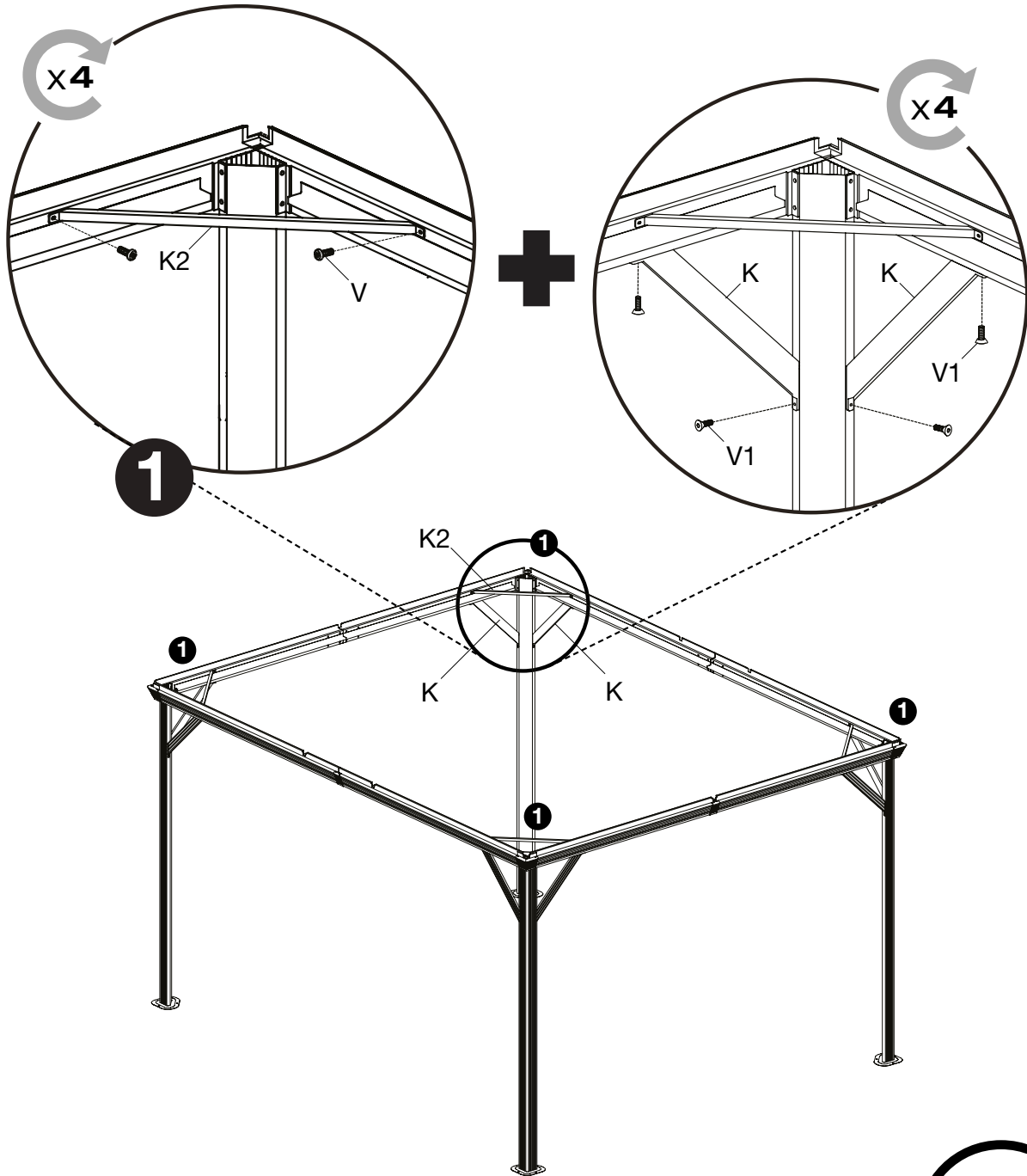

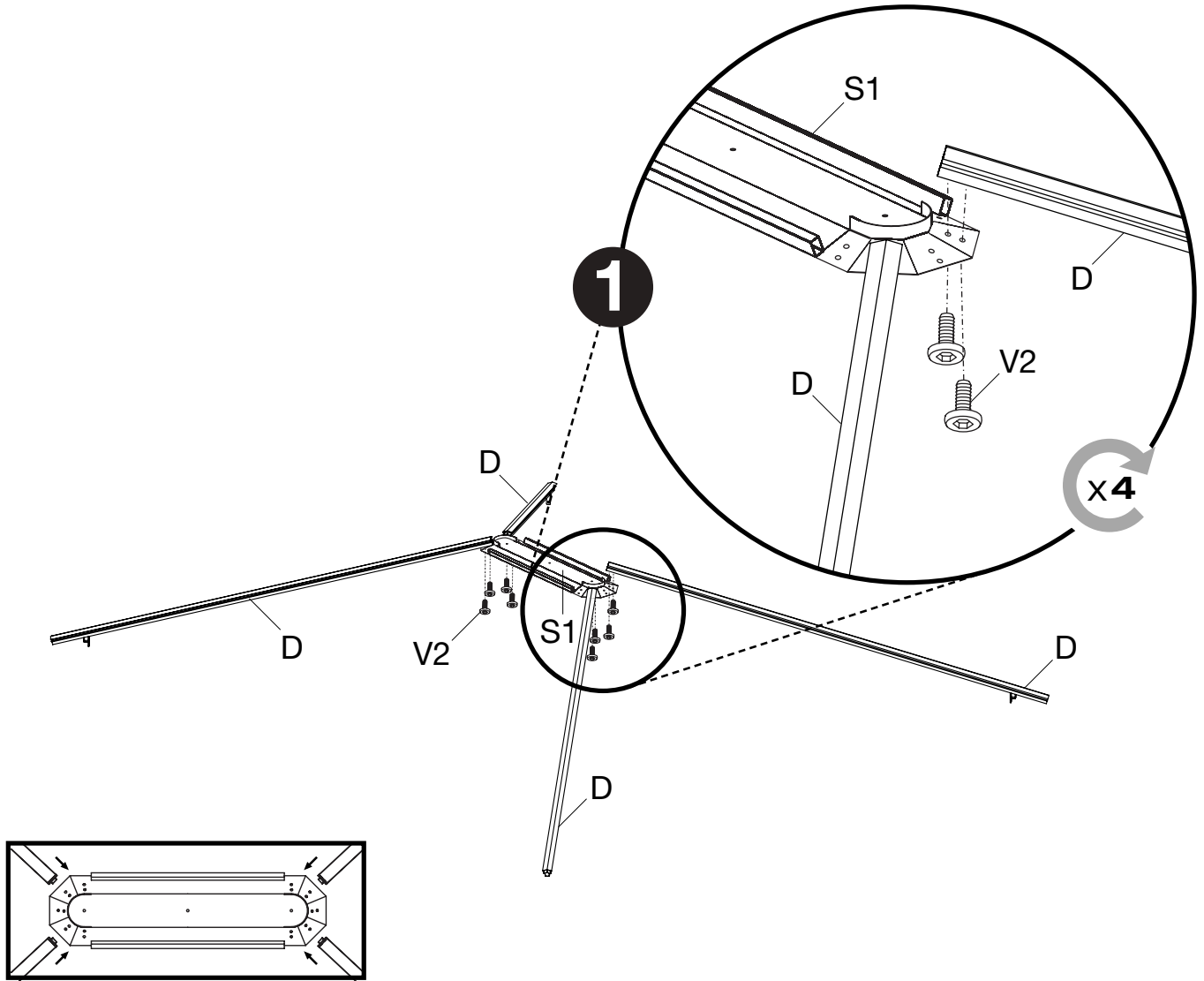

S1x1 Dx4 V2x8

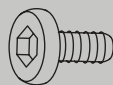
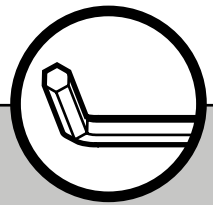
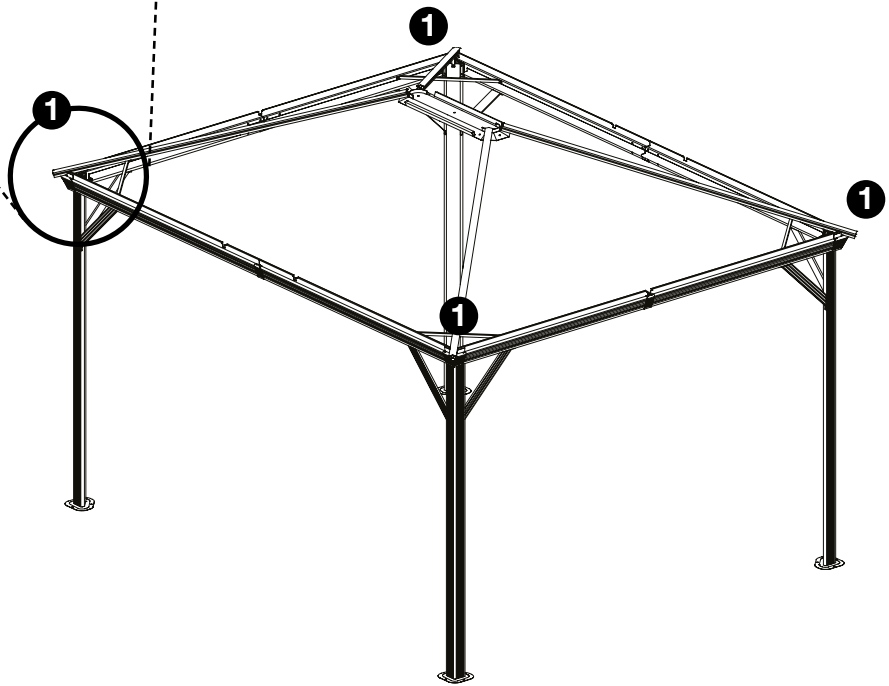
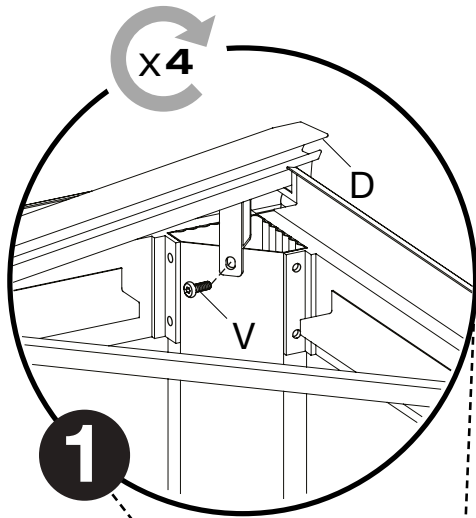

Vx4

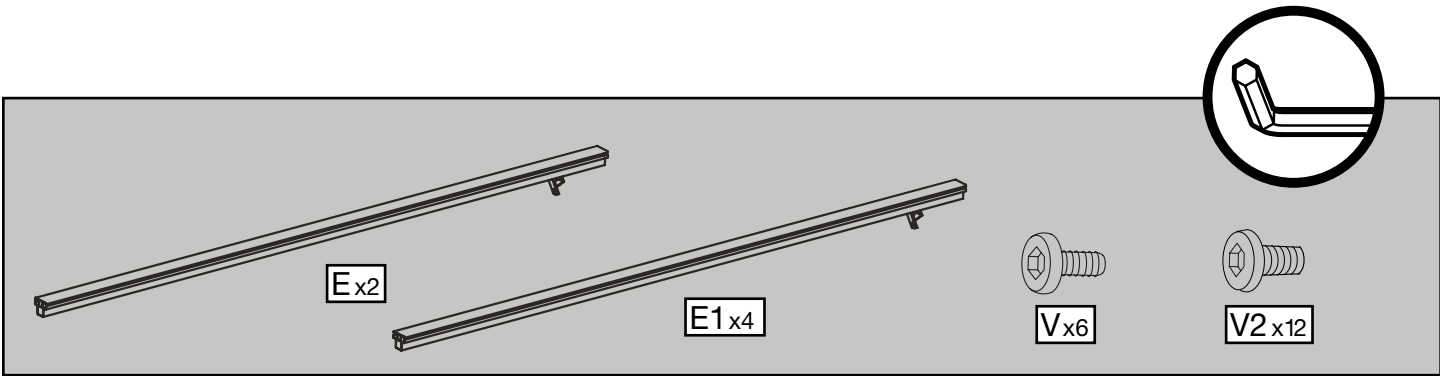
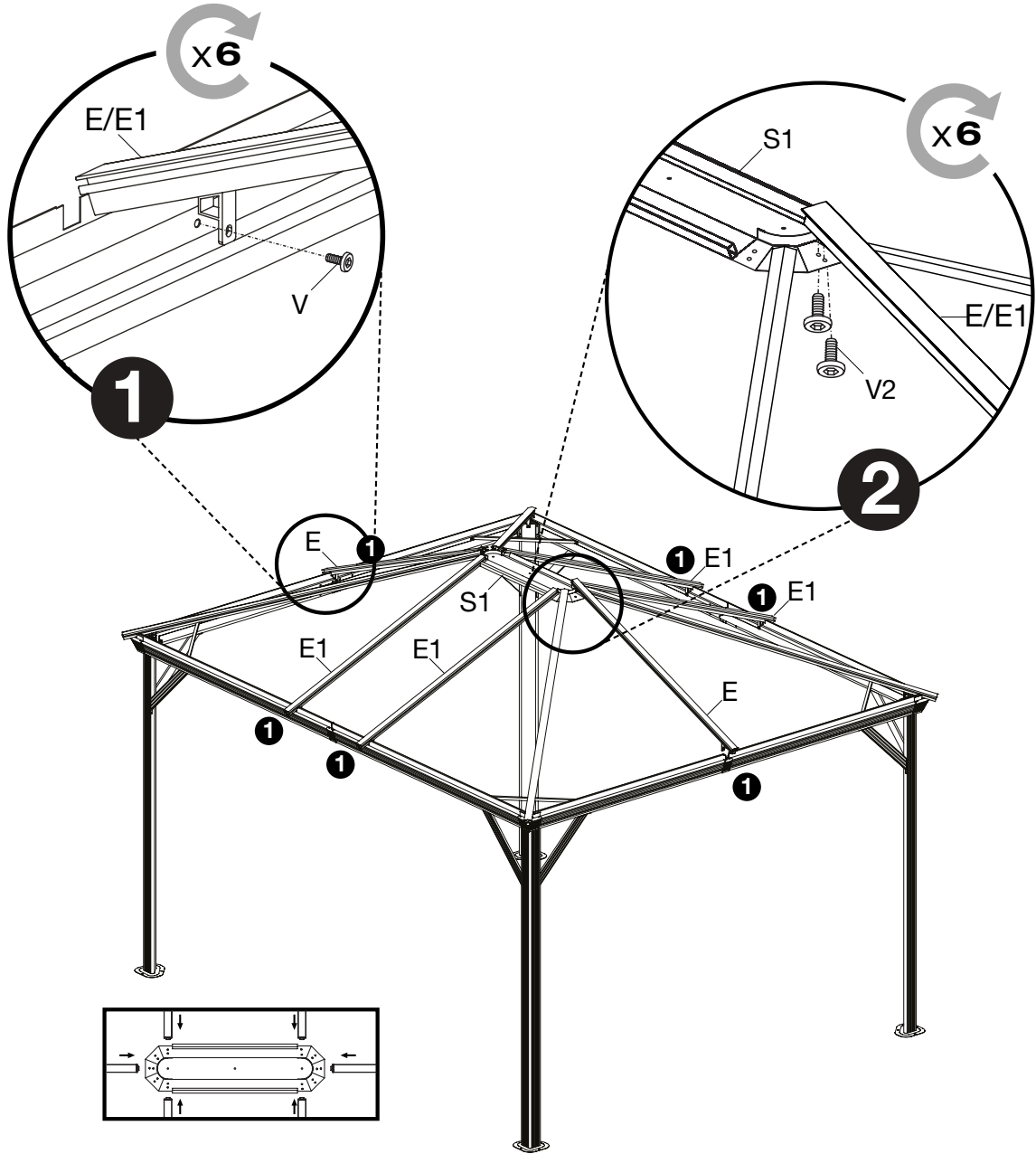

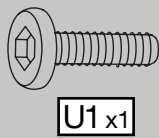
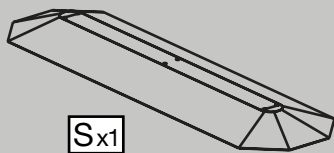
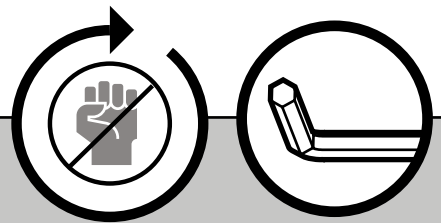
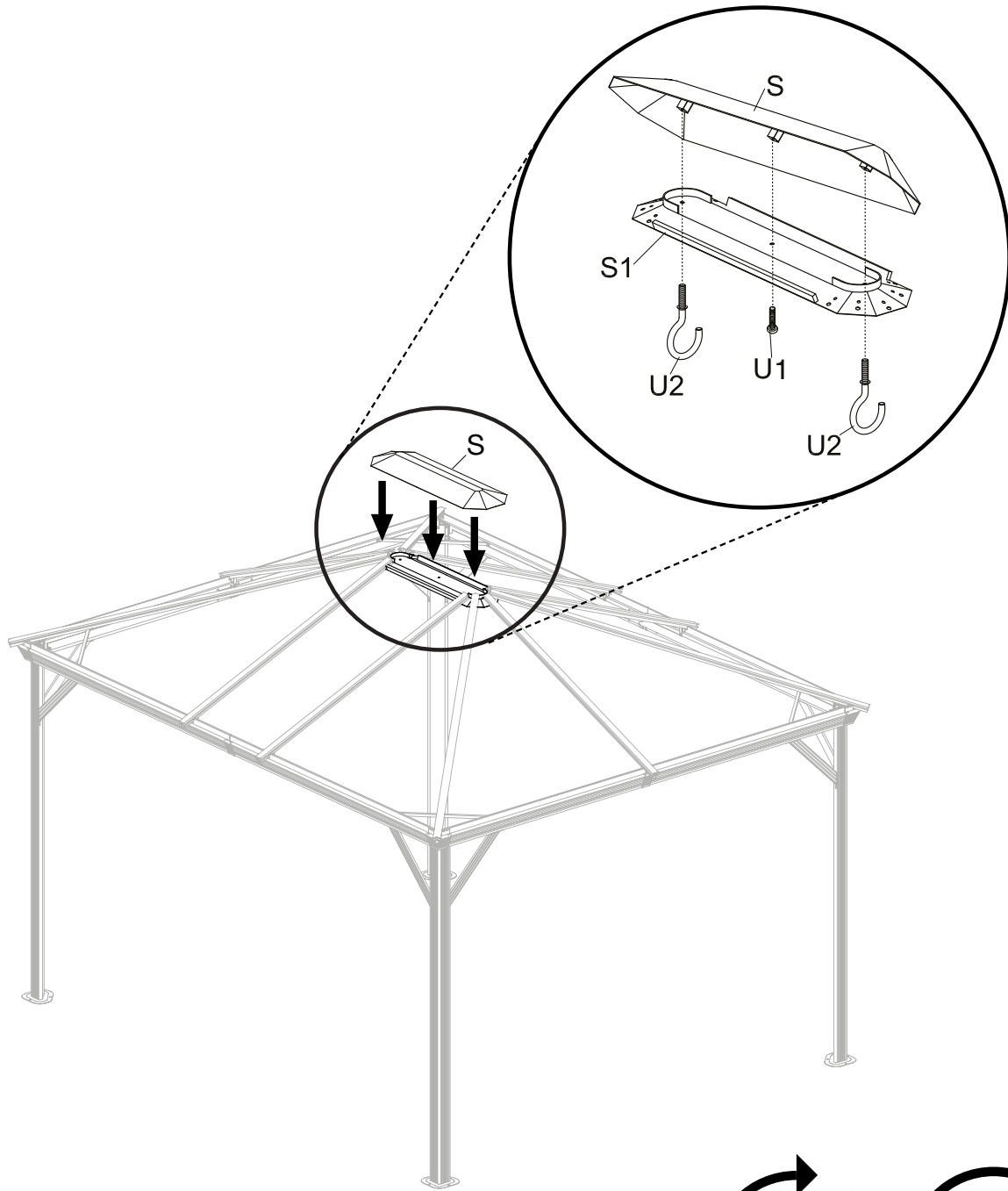

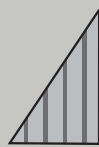
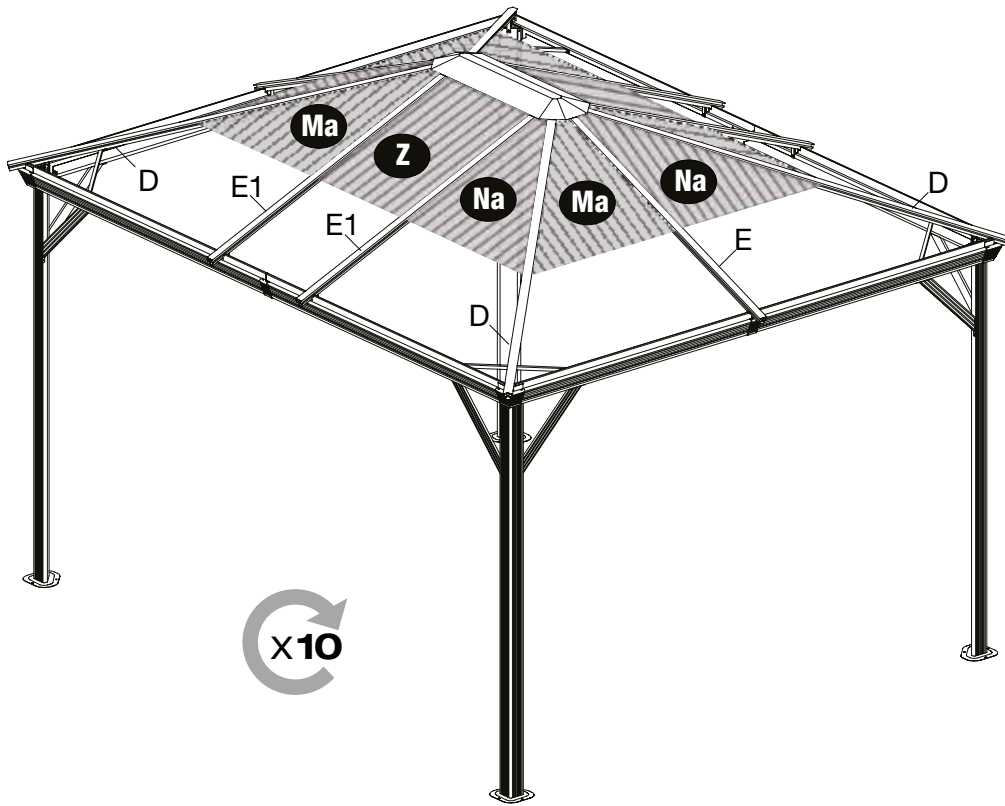
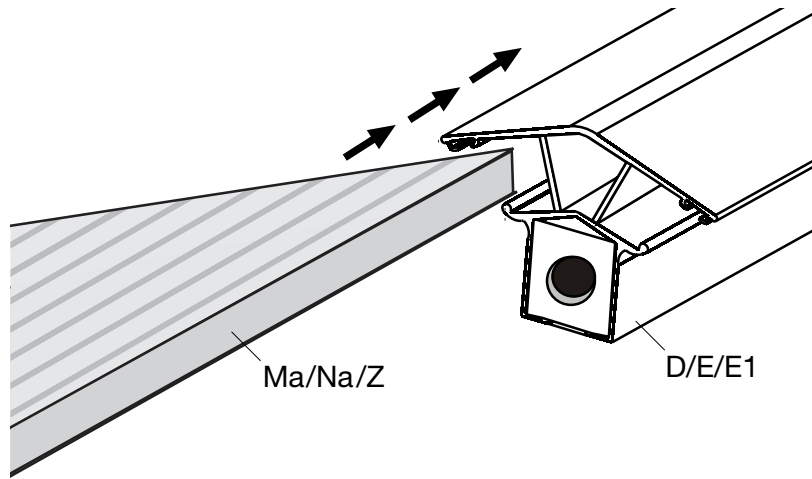

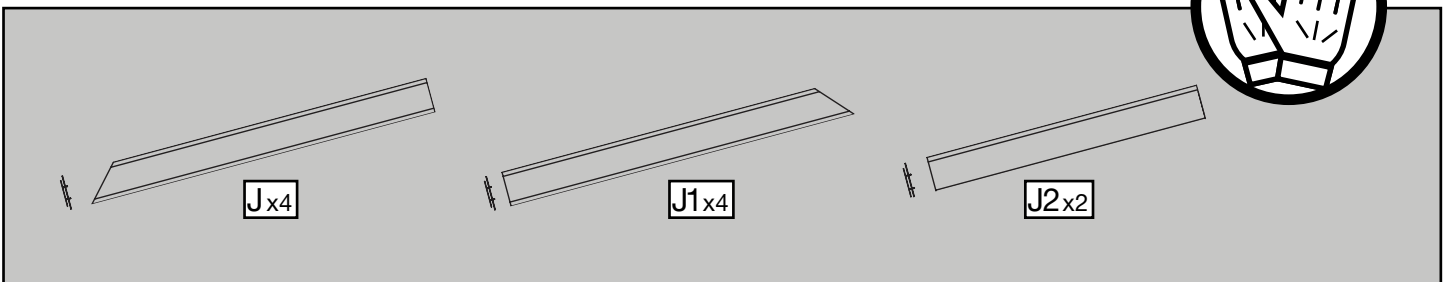
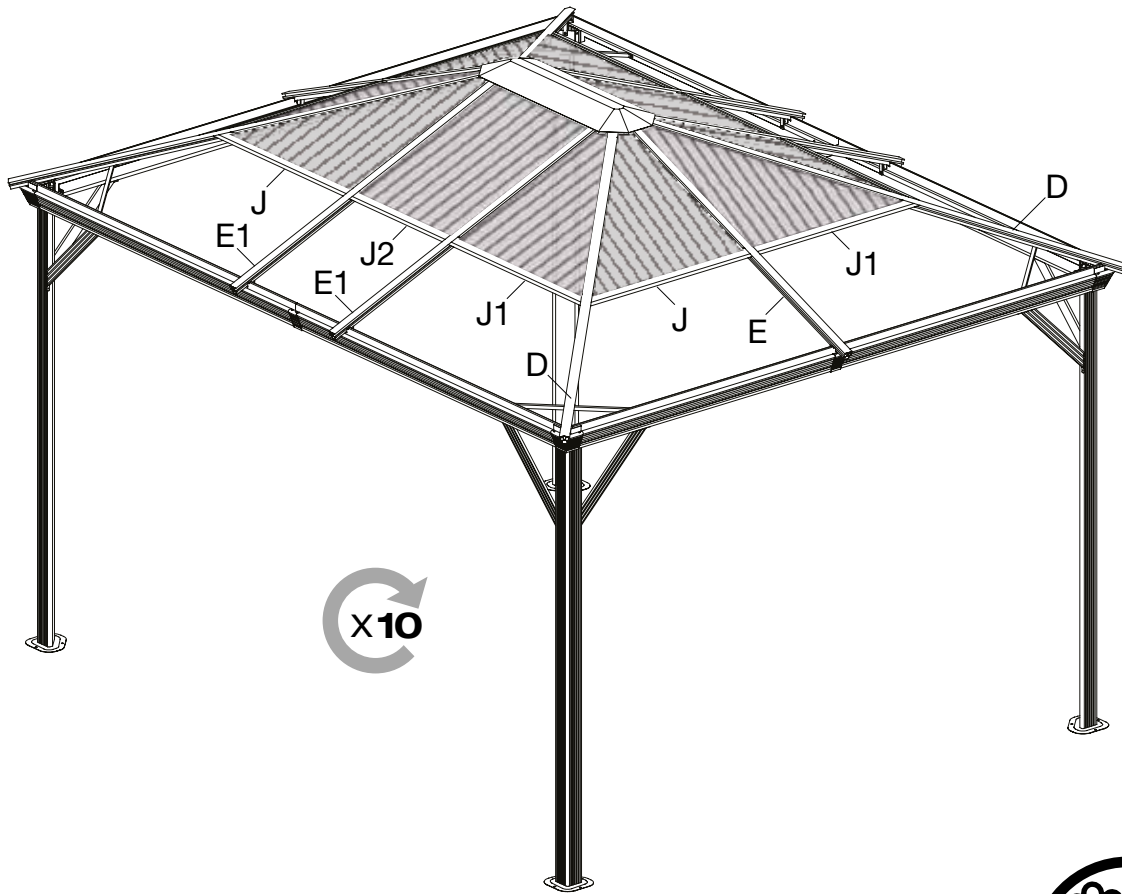
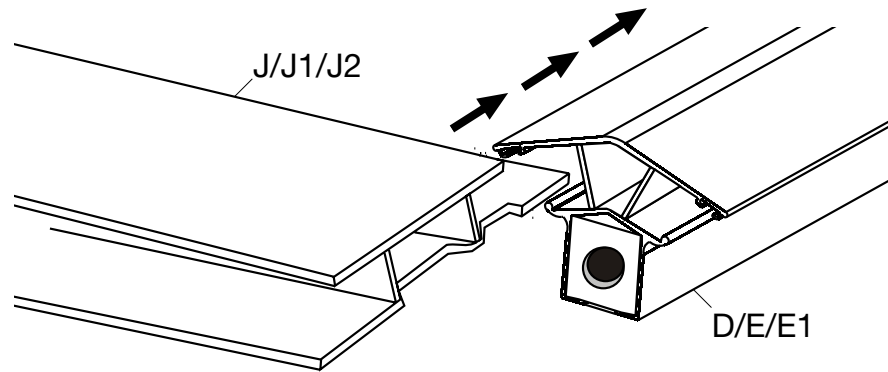

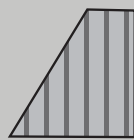
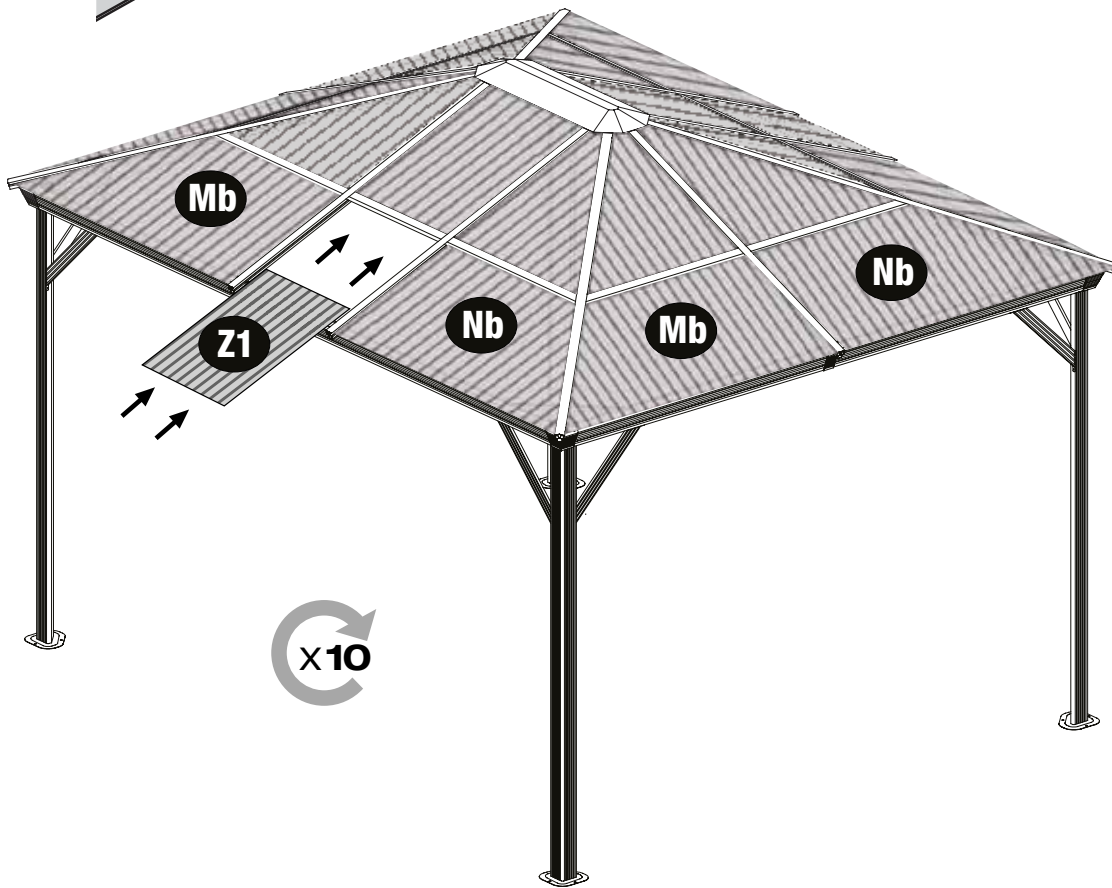
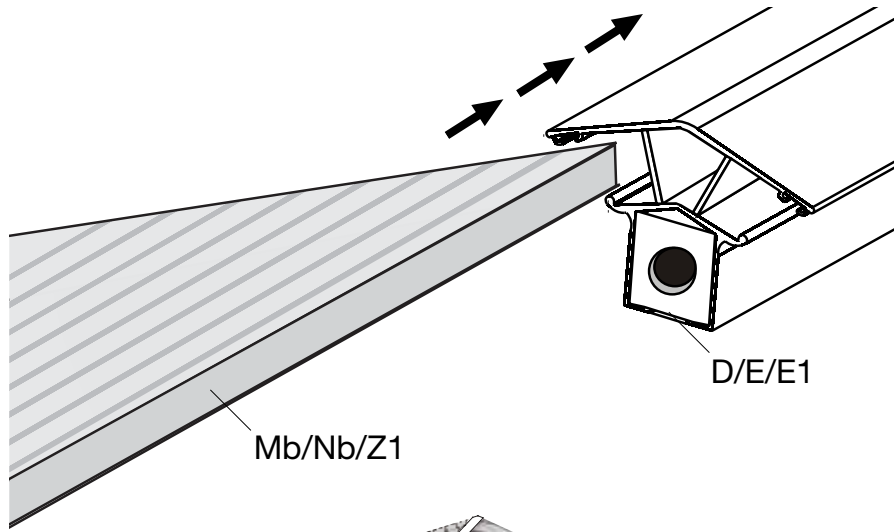

Mb x4

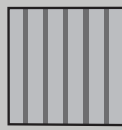

Z1 x2

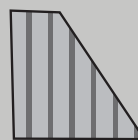

Nb x4

