

**DANCOVER<sup>®</sup>**

**.com**

Manual  
for  
SkyLight Shed Shelf  
0,305x0,847m

**IMPORTANT**

Please read these instructions carefully before you start to assemble this shelf.  
Please carry out the steps in the order set out in these instructions.  
Keep these instructions in a safe place for future reference.

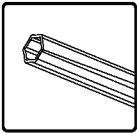
**Tools & Equipment**

(supplied)

**Before Assembly**

- Sort the parts and check according to the contents parts list.
- Some parts may have sharp edges. Please be careful when handling components.
- Following are a number of illustrations depicting possibilities for mounting the SkyLight shelf on all Palram SkyLight Shed sizes.

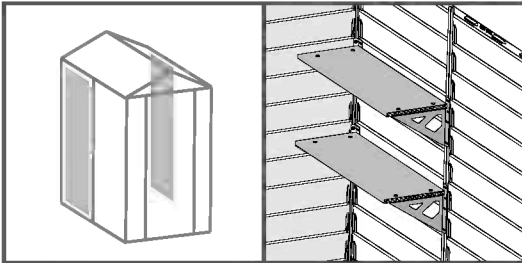
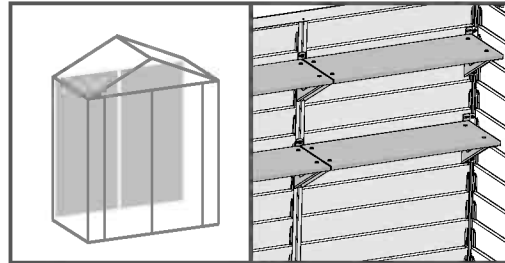
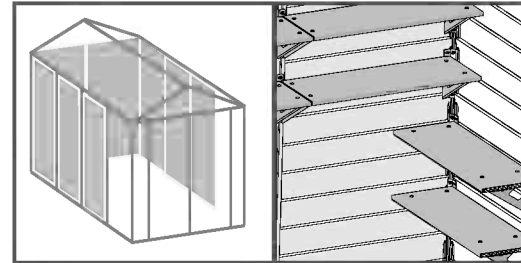
**4x6****6x3****6x5, 6x8, 6x10, 6x12**

- It is highly recommended to plan the assembly prior to starting, according to one of the following options:
- Once you have chosen your preferable option please go to the appropriate page in the Assembly Instructions.

**Option #1:**

Mounting the shelf in the middle of the side wall  
(Page 1)

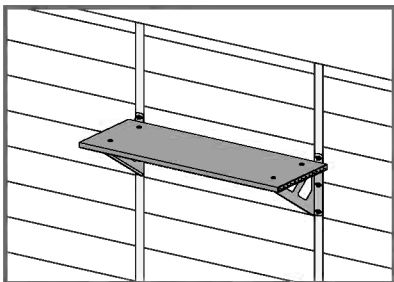

(Not suitable for 4x6 shed)

**Option #2:**

Mounting the shelf where the shelf's left side connects with the shed's corner (Pages 2-3)

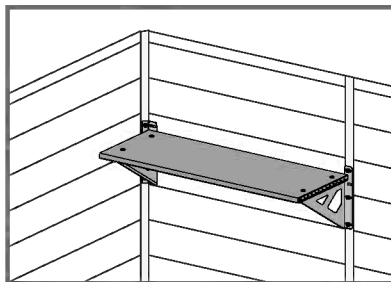
**Option #3:**

Mounting the shelf where the shelf's right side connects with the shed's corner (Pages 4-5)

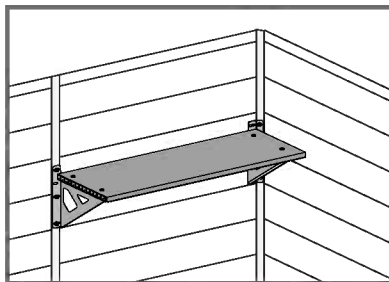
**Option #4:**

Mounting the shelf side by side (only at the shed's rear wall)  
(Page 6)

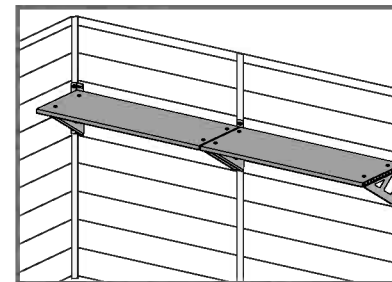

(Not suitable for 4x6 shed)

**⚠ Attention:**

- ✓ Do not mount more than 2 shelves onto one panel.

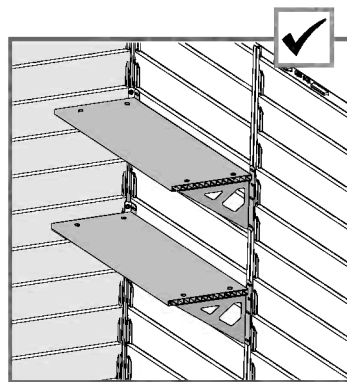
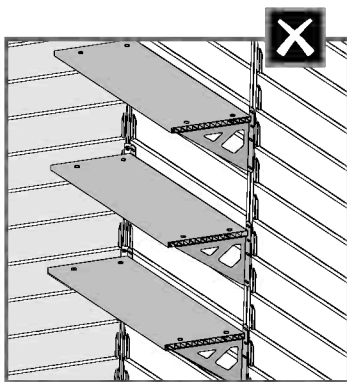

- ✓ Do not mount more than 4 shelves on a single wall.
- ✓ Under any circumstance do not mount more than 10 shelves per shed.
- ✓ A single shelf can carry up to 30 kg (66 lbs).

## During Assembly

- ✓ Panel (#8076) is not pre-drilled; therefore you must drill the holes with accordance to your chosen option.
- ✓ Metal plate (#8075) is used to mounting the shelf onto either one of the shed's corners. If you did not choose this option, there is no need to use this part; keep it for future use if needed.
- ✓ Tighten all screws when completing assembly.

Do not tighten screws and nuts (411 & 412) until completion of assembly process. These 2 icons indicate if screws' tightening is required or not.

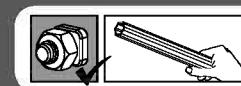

**IMPORTANT**

Veuillez lire attentivement ces instructions avant de commencer à assembler cette étagère.  
Veuillez réaliser les étapes suivant l'ordre décrit dans les présentes instructions.  
Conservez ces instructions dans un endroit sûr pour référence future.

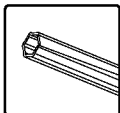
**Outils et équipement**

(fournis)

**Avant de réaliser l'assemblage**

- Triez les pièces et vérifiez le contenu selon la liste des composants.
- Certaines pièces pourraient avoir des arêtes tranchantes. Veuillez agir avec prudence lors de la manipulation de l'un des composants.
- Vous trouverez ci-dessous un certain nombre d'illustrations représentant les différentes possibilités de monter l'étagère sur toutes les tailles de Skylight Palram pour remise.

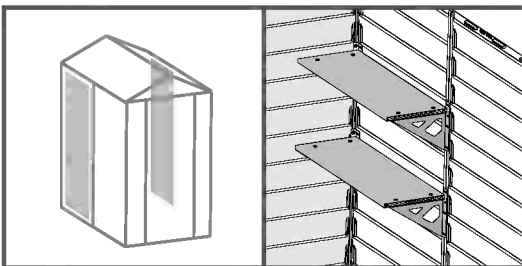
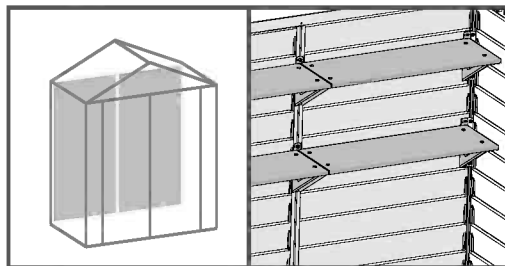
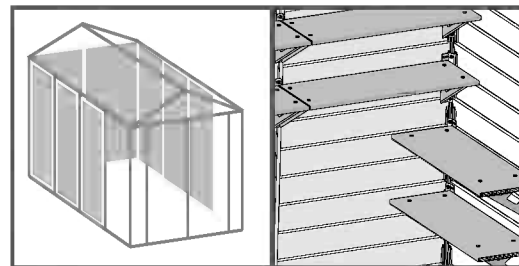
**4x6****6x3****6x5, 6x8, 6x10, 6x12**

- Il est fortement recommandé de planifier l'assemblage avant de le commencer, selon les options suivantes :
- Une fois que vous avez choisi votre option privilégiée, veuillez vous rendre à la page appropriée dans les instructions d'assemblage.

**Option n° 1:**

Montage de l'étagère au milieu de la paroi latérale  
(Page 1)

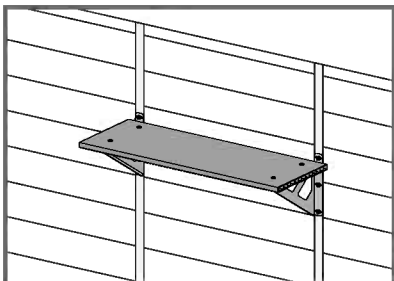

(Ne convient pas aux remises de taille 4 x 6).

**Option n° 2:**

Montage de l'étagère à l'endroit où le côté gauche de l'étagère se connecte avec le coin de la remise  
(Pages 2-3)

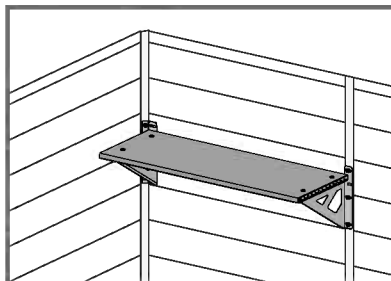
**Option n° 3:**

Montage de l'étagère à l'endroit où le côté droit de l'étagère se connecte avec le coin de la remise  
(Pages 4-5)

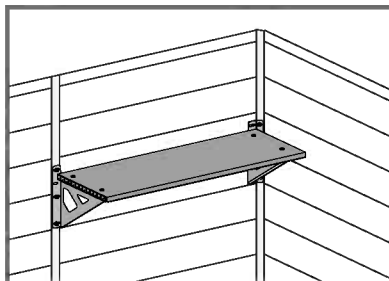
**Option n° 4:**

Montage de l'étagère côté à côté (uniquement à la paroi arrière de la remise)  
(Page 6)

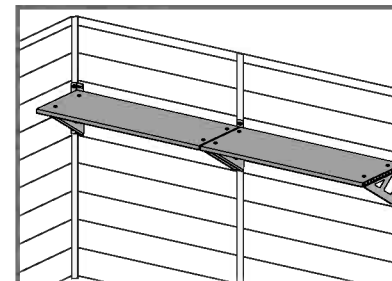

(Ne convient pas aux remises de taille 4 x 6).

**Attention:**

- Ne montez pas plus de deux étagères sur un panneau.

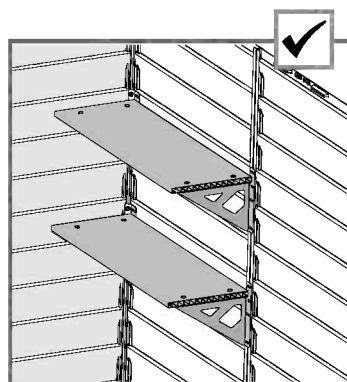
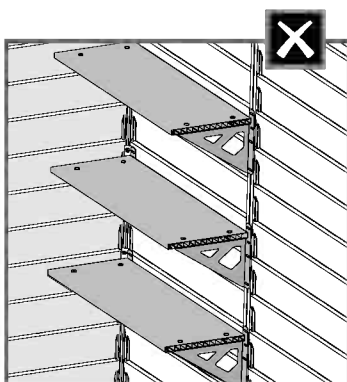

- Ne montez pas plus de 4 étagères sur un seul mur.
- Ne montez jamais plus de 10 étagères par remise.
- Une seule étagère peut supporter jusqu'à 30 kg (66 lb).

**Durant l'assemblage**

- Le panneau (# 8076) n'est pas pré-percé ; vous devrez donc percer les trous conformément à l'option que vous avez choisie.
- La plaque métallique (# 8075) est utilisée pour le montage de l'étagère sur l'un des coins de la remise. Si vous n'avez pas choisi cette option, il ne sera pas nécessaire de l'utiliser; conservez-la pour une utilisation future en cas de besoin.
- En fin d'assemblage, veillez à bien resserrer toutes les vis.

Ne serrez pas les vis et les écrous (411 & 412) jusqu'à la fin du processus d'assemblage. Ces deux icônes indiquent si le resserrement des vis est nécessaire ou pas.

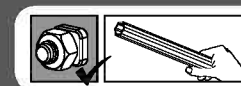

**WICHTIG**

Bitte lesen Sie diese Anleitung aufmerksam durch, bevor Sie mit der Montage dieses Regals beginnen.  
Bitte führen Sie die einzelnen Schritte in der in dieser Anleitung angegebenen Reihenfolge durch.  
Bewahren Sie diese Anleitung für späteren Gebrauch sicher auf.

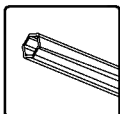
**Werkzeug & Ausrüstung**

(geliefert)

**Vor dem Aufbau**

- Sortieren Sie die einzelnen Teile und gleichen Sie sie mit der Inhaltsliste ab.
- Einige Teile haben scharfe Kanten. Bitte seien Sie vorsichtig im Umgang mit den einzelnen Bestandteilen.
- Im Folgenden finden Sie einige Illustrationen, welche die Montagemöglichkeiten für das SkyLight-Regal auf den Palram SkyLight Gartenhäuschen jeder Größe darstellen.

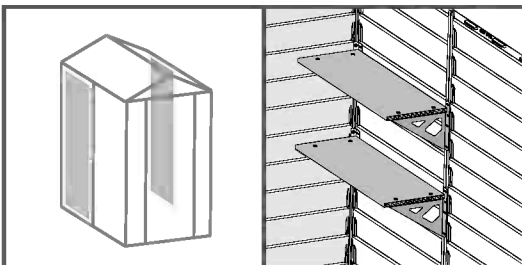
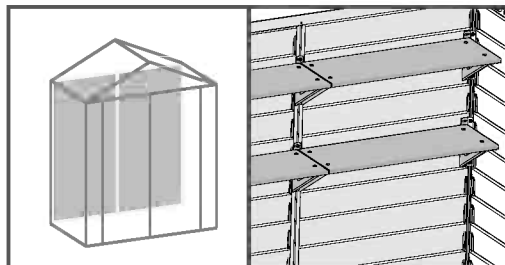
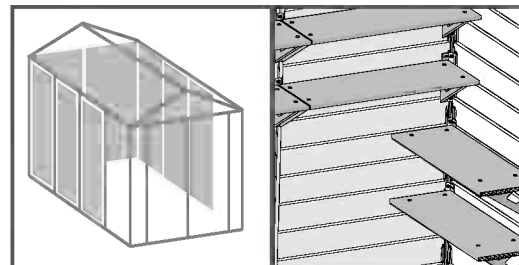
**4x6****6x3****6x5, 6x8, 6x10, 6x12**

- Es wird dringend empfohlen, den Aufbau je nach einer der folgenden Möglichkeiten zu planen, bevor damit begonnen wird:
- Wenn Sie sich für eine Möglichkeit entschieden haben, schlagen Sie bitte die entsprechende Seite der Montageanleitung auf.

**Möglichkeit Nr.1:**

Das Regal in der Mitte der Seitenwand anbringen  
(Seite 1)

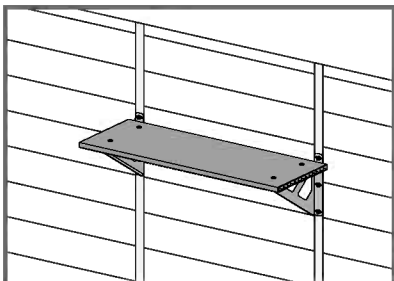

(Nicht geeignet für das 4x6 Gartenhaus)

**Möglichkeit Nr.2:**

Das Regal so montieren, dass sich seine linke Seite in der Ecke des Gartenhauses befindet  
(Seiten 2-3)

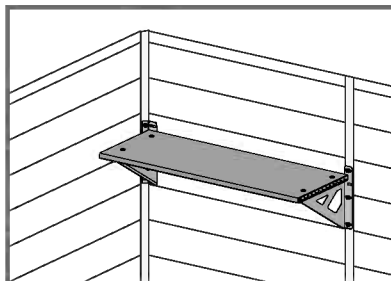
**Möglichkeit Nr.3:**

Das Regal so montieren, dass sich seine rechte Seite in der Ecke des Gartenhauses befindet  
(Seiten 4-5)

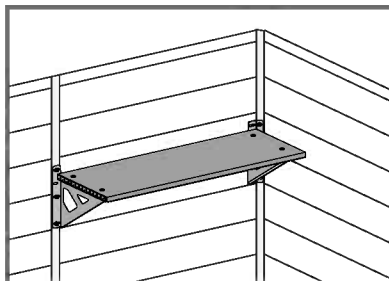
**Möglichkeit Nr.4:**

Das Regal seitlich anbringen (nur an der Rückwand des Gartenhauses)  
(Seite 6)

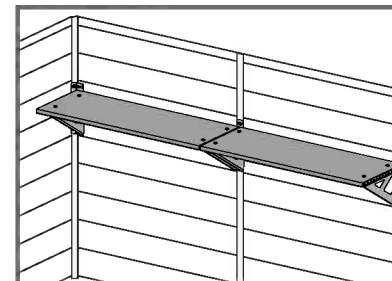

(Nicht geeignet für das 4x6 Gartenhaus)

**⚠ Vorsicht:**

- ✓ Montieren Sie nicht mehr als 2 Regale an ein Panel.

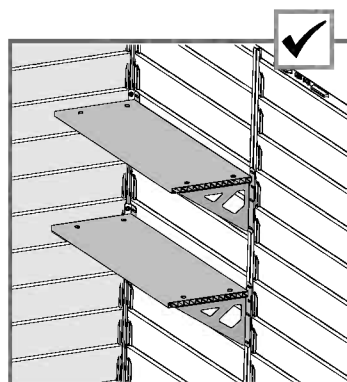
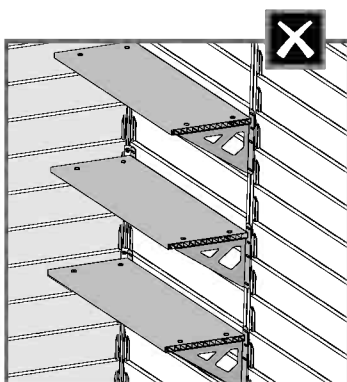

- ✓ Montieren Sie nicht mehr als 4 Regale an eine einzige Wand.
- ✓ Montieren Sie auf keinen Fall mehr als 10 Regale pro Gartenhaus.
- ✓ Ein Regal kann bis zu 30 kg tragen (66 lbs)

## Während des Ausbaus

- ✓ Das Panel (**Nr.8076**) wurde nicht vorgebohrt; deshalb müssen Sie die Löcher entsprechend der von Ihnen gewählten Option bohren.
- ✓ Die Metallplatte (**Nr.8075**) wird dazu verwendet, das Regal auf eine der Ecken des Gartenhauses zu montieren. Wenn Sie diese Option nicht gewählt haben, benötigen Sie die Platte nicht; bewahren Sie sie für eventuellen zukünftigen Bedarf auf.
- ✓ Ziehen Sie bei Beendigung des Aufbaus alle Schrauben fest.

Ziehen Sie die Schrauben und Muttern (411 & 412) nicht fest, bevor der Aufbau beendet wurde. Diese zwei Symbole zeigen an, ob ein Festziehen der Schrauben nötig ist oder nicht.

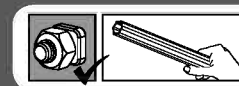

**IMPORTANTE**

Por favor, lea cuidadosamente estas instrucciones antes de empezar a montar esta estantería. Por favor, lleve a cabo los pasos en el orden indicado en estas instrucciones. Guarde estas instrucciones en un lugar seguro para futuras referencias.

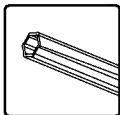
**Herramientas y equipo**

(incluidos)

**Antes del montaje**

- Ordene las piezas y compruébelas usando la lista de contenidos.
- Algunas piezas pueden tener bordes afilados. Por favor, tenga cuidado al manipular los componentes.
- A continuación se muestra una serie de ilustraciones que muestran las posibilidades para montar la estantería Skylight en todos los tamaños de cobertizos SkyLight.

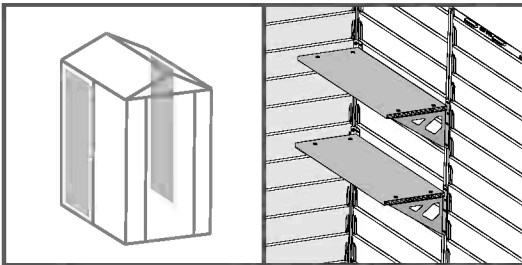
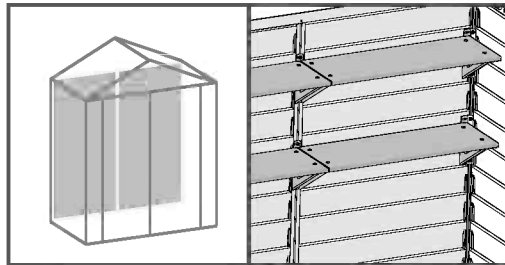
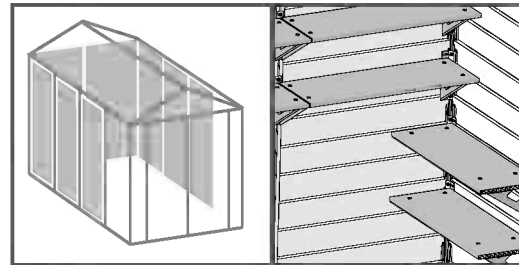
**4x6****6x3****6x5, 6x8, 6x10, 6x12**

- Se recomienda encarecidamente planificar previamente el montaje antes de comenzar, siguiendo una de las siguientes opciones:
- Una vez que ha seleccionado su opción preferida, por favor, acuda a la página adecuada en las instrucciones de montaje.



**Opción n.º 1:**

Montar la estantería en el medio de la pared lateral  
(Página 1)

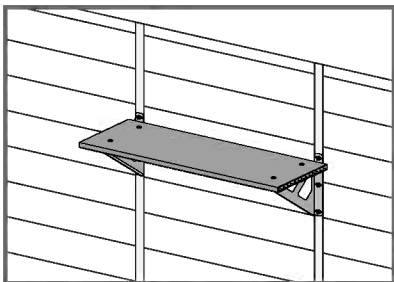

(No apto para el cobertizo 4x6)

**Opción n.º 2:**

Montar la estantería donde la parte izquierda del cobertizo se une con la esquina del cobertizo  
(Páginas 2-3)

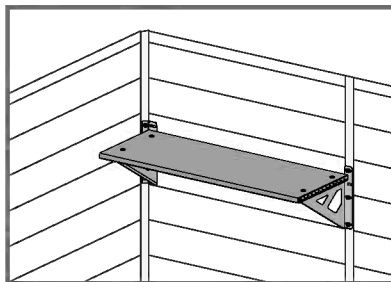
**Opción n.º 3:**

Montar la estantería donde la parte derecha del cobertizo se une con la esquina del cobertizo  
(Páginas 4-5)

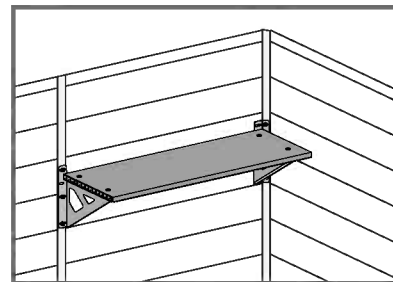
**Opción n.º 4:**

Montar la estantería una al lado de otra (solo en la pared trasera del cobertizo)  
(Página 6)

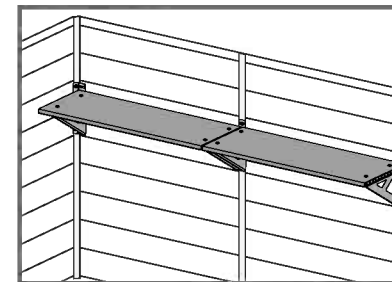

(No apto para el cobertizo 4x6)

**⚠ Atención:**

- ✓ No monte más de 2 estanterías en un panel.

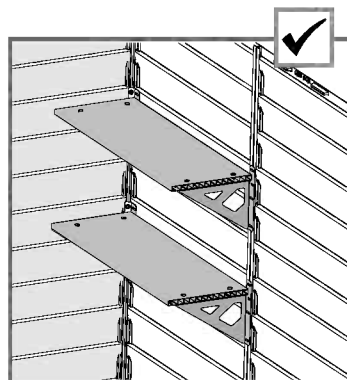
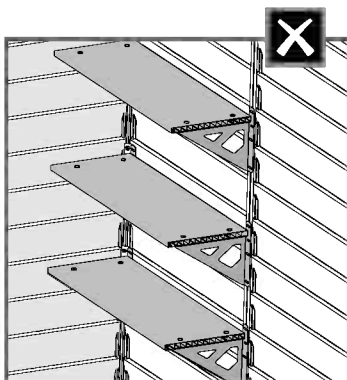

- ✓ No monte más de 4 estanterías en una única pared.
- ✓ Bajo ninguna circunstancia monte más de 10 estanterías por cobertizo.
- ✓ Una única estantería puede soportar hasta 30 kg (66 lb).

**Durante el montaje**

- ✓ El panel n.º 8076 no viene pretaladrado; por lo tanto, deberá taladrar los agujeros según la opción que haya elegido.
- ✓ La placa metálica n.º 8075 se utiliza para montar la estantería en una de las dos esquinas del cobertizo. Si no ha elegido esta opción, no necesitará utilizar esta pieza; guárdela por si la utiliza en el futuro.
- ✓ Apriete todos los tornillos al finalizar el montaje.

No apriete los tornillos y tuercas (411 y 412) hasta finalizar el proceso de montaje. Estos 2 iconos muestran si es o no necesario apretar los tornillos.

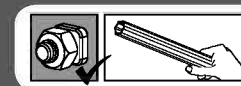

**IMPORTANT**

Vă rugăm să citiți aceste instrucțiuni cu atenție, înainte de a începe să asamblați acest raft.  
Vă rugăm să urmați pașii în ordinea stabilită în aceste instrucțiuni.  
Vă rugăm să păstrați aceste instrucțiuni într-un loc sigur, pentru consultare ulterioară.

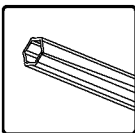
**Unelte și echipament**

(furnizate)

**Înainte de asamblare**

- Sortați piesele și verificați-le prin comparație cu lista componentelor.
- Unele piese au margini ascuțite. Vă rugăm să fiți atenți când manevrați componentele.
- În cele ce urmează veți vedea câteva ilustrații ce descriu posibilitățile de montare a raftului SkyLight în barăcile Palram SkyLight de toate mărimile.

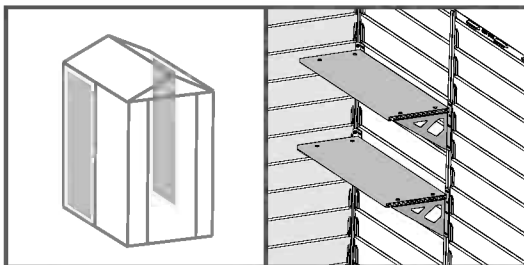
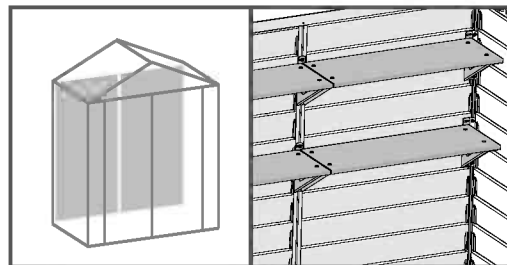
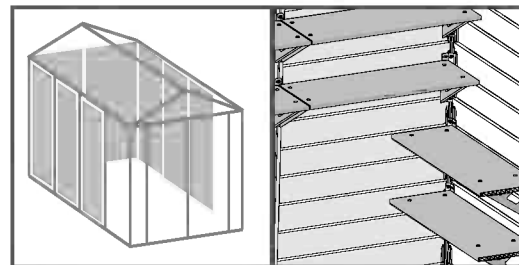
**4x6****6x3****6x5, 6x8, 6x10, 6x12**

- Se recomandă să planificați asamblarea înainte de a începe efectiv, conform uneia dintre următoarele opțiuni:
- Când ați ales opțiunea pe care o preferați, vă rugăm să mergeți la pagina corespunzătoare din „Instrucțiuni de asamblare”.

**Opțiunea 1:**

Montarea raftului în mijlocul peretelui lateral (**pagina 1**)

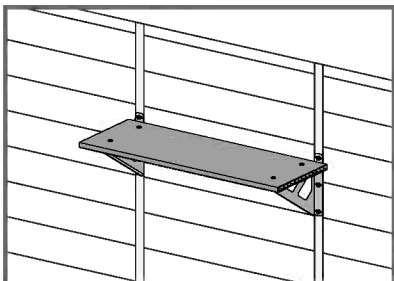

(Neadecvat pentru baraca 4x6)

**Opțiunea 2:**

Montarea raftului când partea laterală stângă a raftului se conectează la colțul barăcii (**paginile 2-3**)

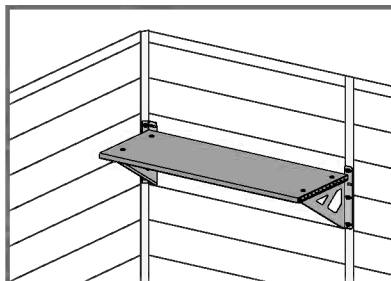
**Opțiunea 3:**

Montarea raftului când partea laterală dreaptă a raftului se conectează la colțul barăcii (**paginile 4-5**)

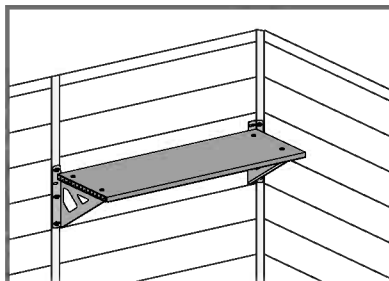
**Opțiunea 4:**

Montarea rafturilor unul lângă altul (doar la peretele din spate al barăcii) (**pagina 6**)

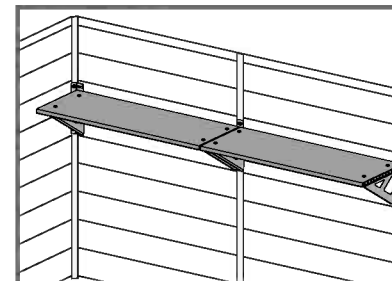

(Neadecvat pentru baraca 4x6)

**⚠️ Atenție:**

- ✓ Nu montați mai mult de 2 rafturi pe un panou.

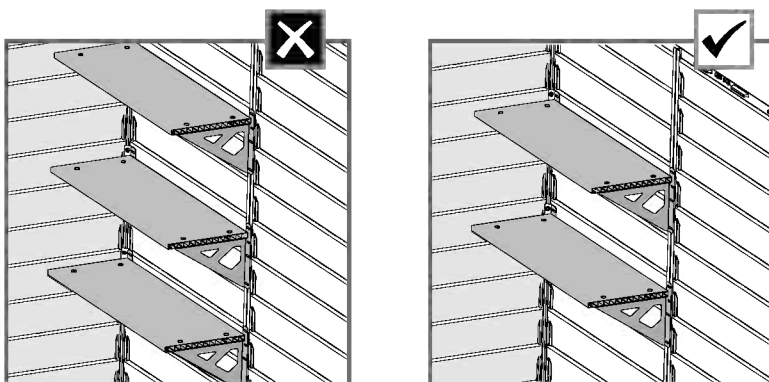

- ✓ Nu montați mai mult de 4 rafturi pe un singur perete.
- ✓ Sub nicio formă, nu montați mai mult de 10 rafturi per baracă.
- ✓ Un singur raft poate suporta până la 30 kg (66 livre).







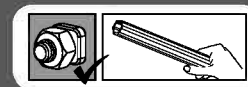

**În cursul asamblării**

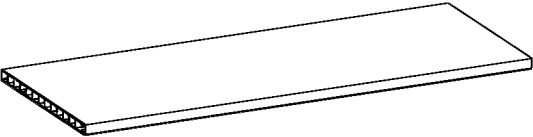
- ✓ Panoul (**8076**) nu este găurit în prealabil, așadar, trebuie să dați găuri conform opțiunii alese.
- ✓ Placa de metal (**8075**) este utilizată pentru a monta raftul în oricare dintre colțurile barăcii. Dacă nu ați ales această opțiune, nu este necesar să utilizați această piesă. Păstrați-o pentru o utilizare ulterioară, dacă va fi cazul.
- ✓ Strângeți toate șuruburile, atunci când încheiați asamblarea.

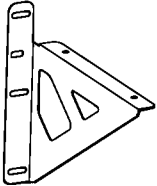
Nu strângeți complet șuruburile și piulițele (411 și 412) până la finalizarea procesului de asamblare. Aceste 2 pictograme arată dacă strângerea șuruburilor este necesară sau nu.

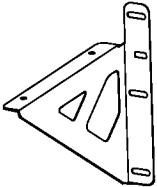

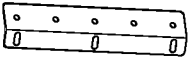
# Contents

Item		Qty.	Item		Qty.
8076		1	8077		4
8074		1	466		14
8073		1	461		6
8075		1	411		4
			T001		1

# 1

## Option #1

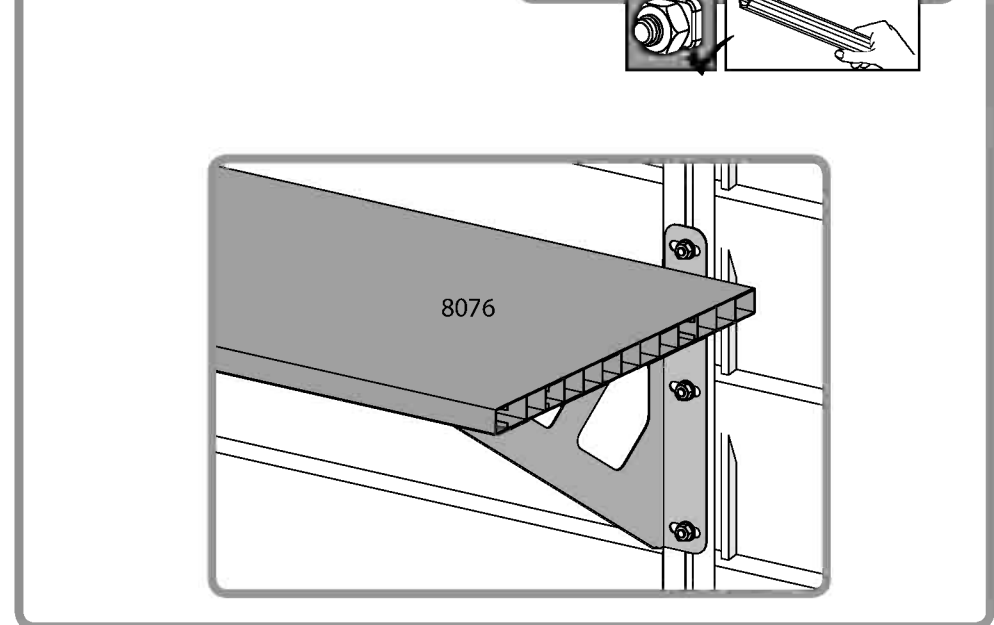
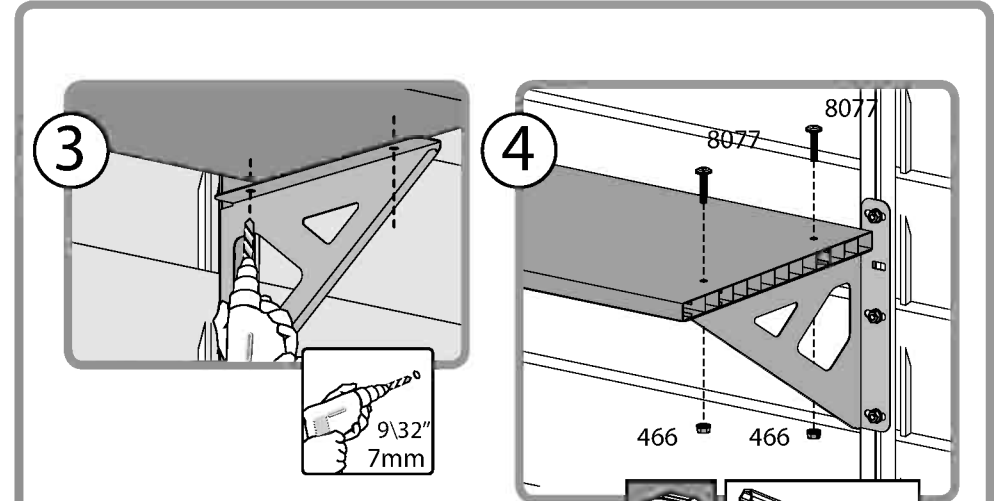
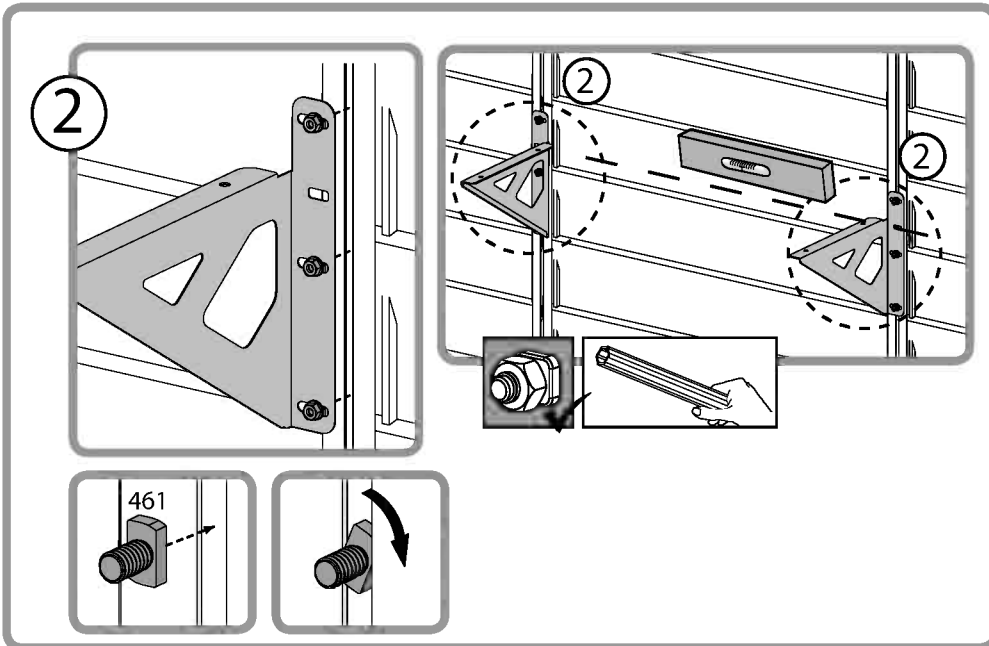
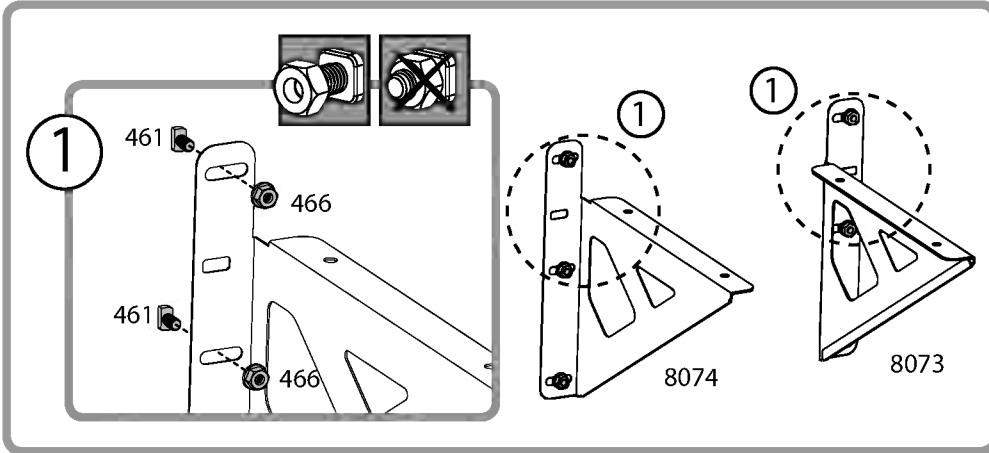
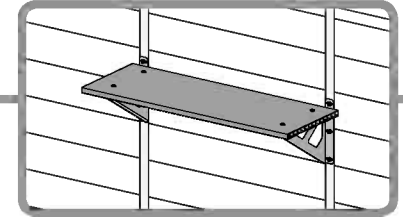

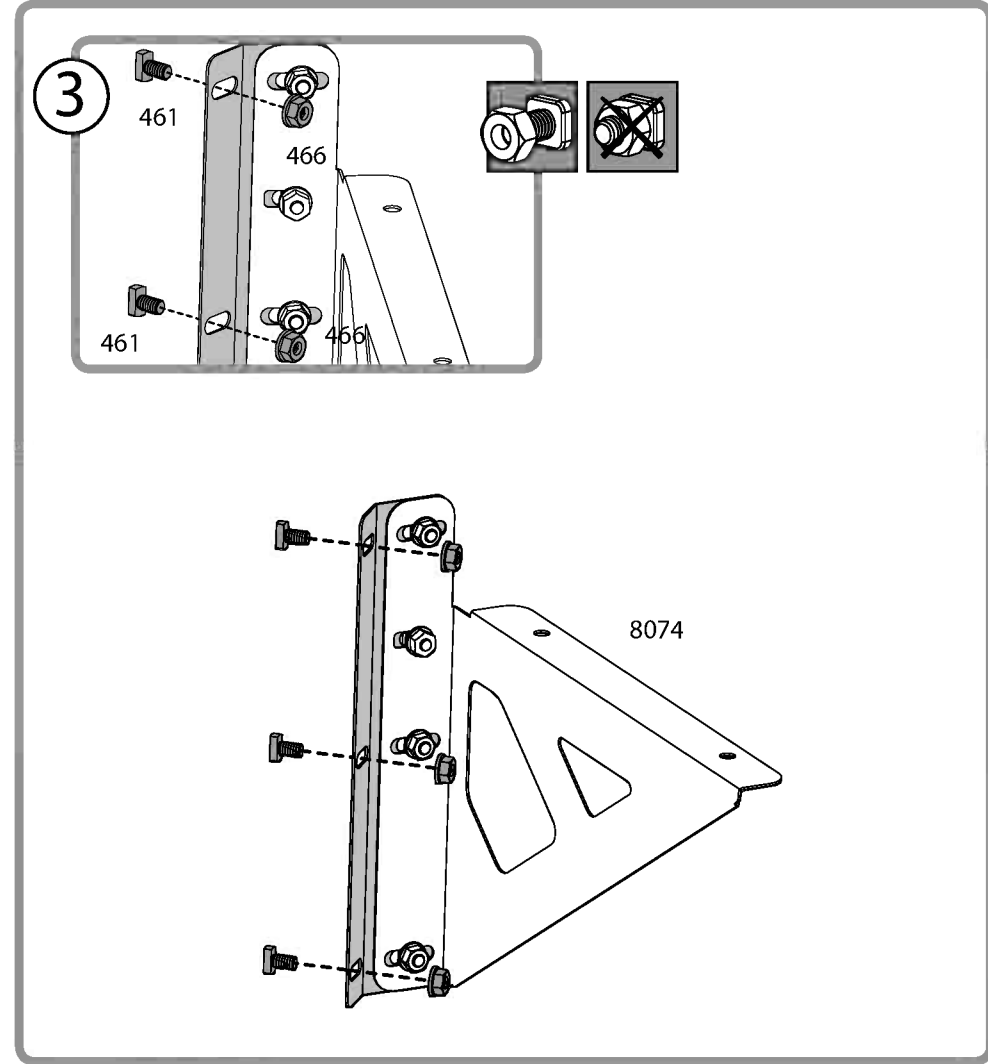
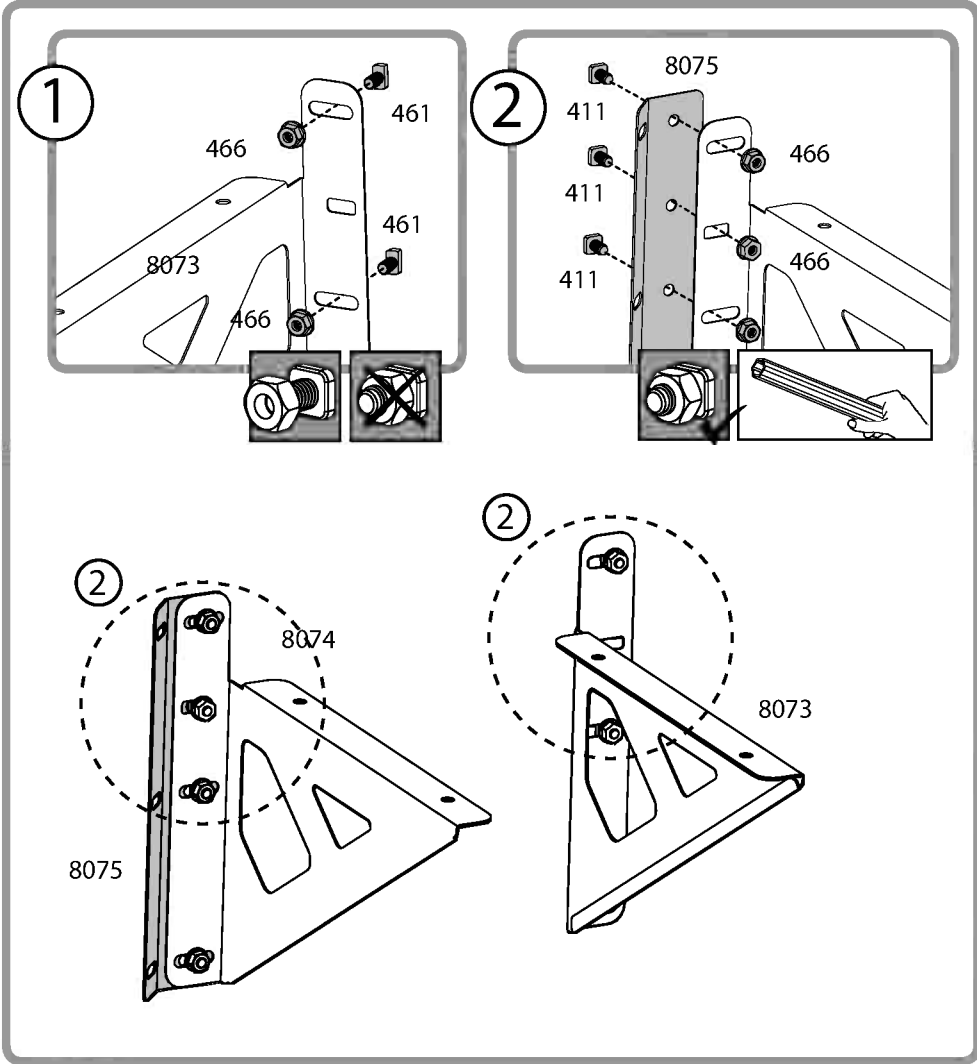
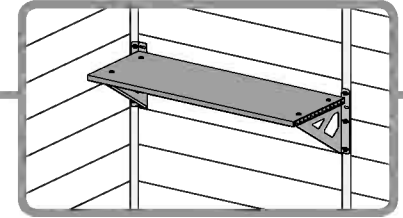

# 2 Option #2

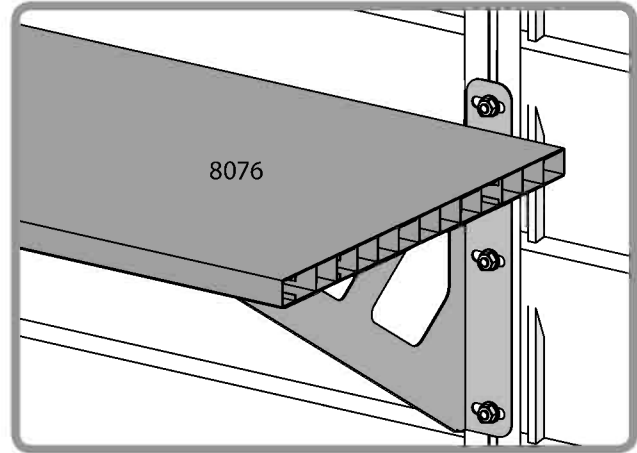
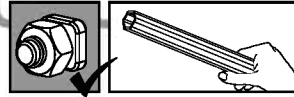
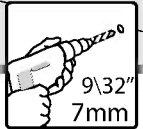
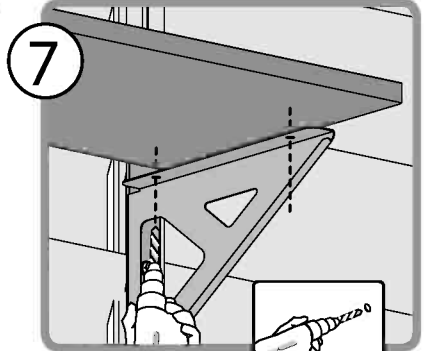
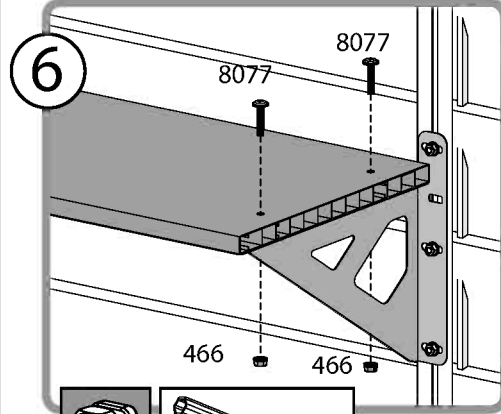
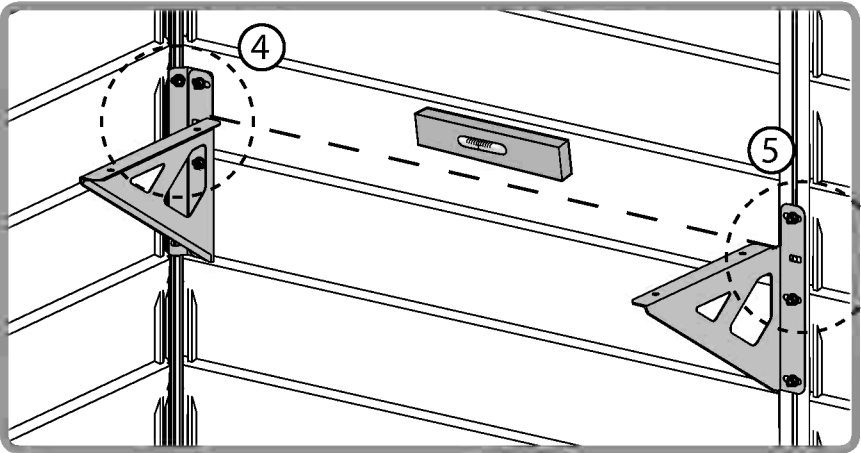
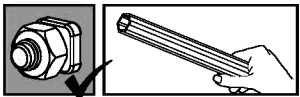
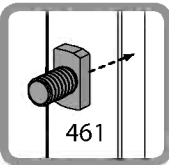
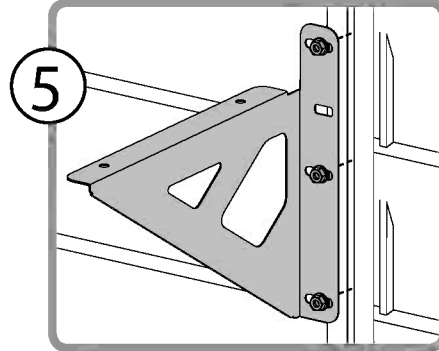
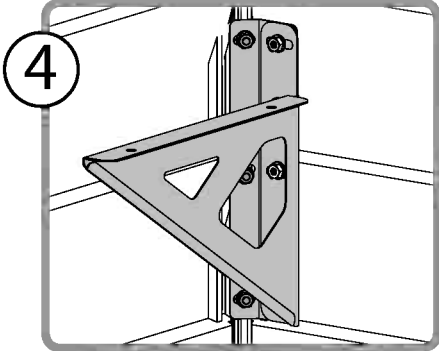
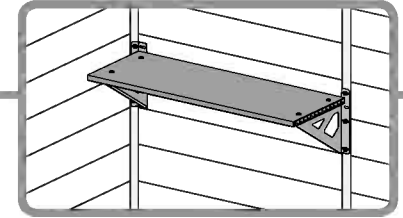

**5** Option #3

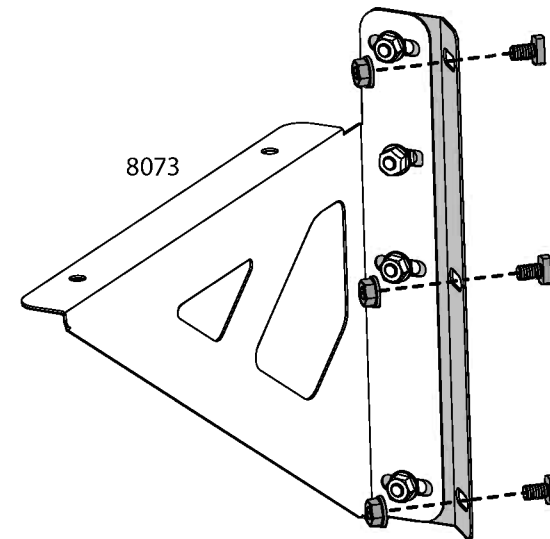
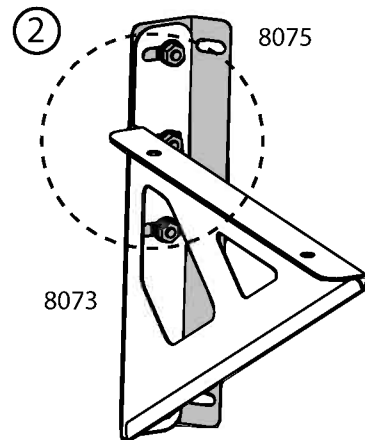
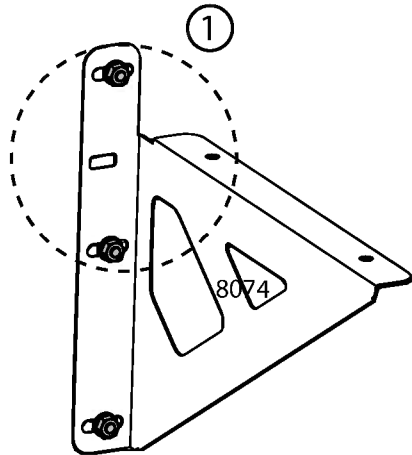
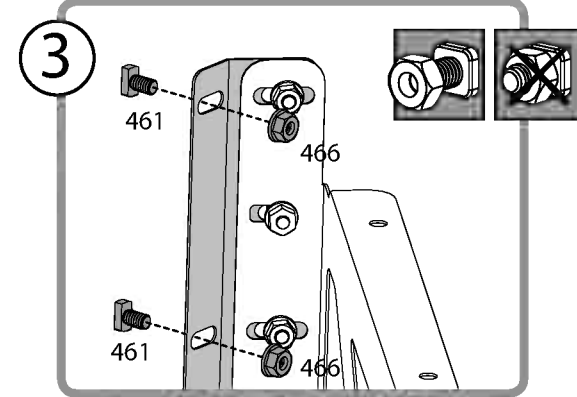
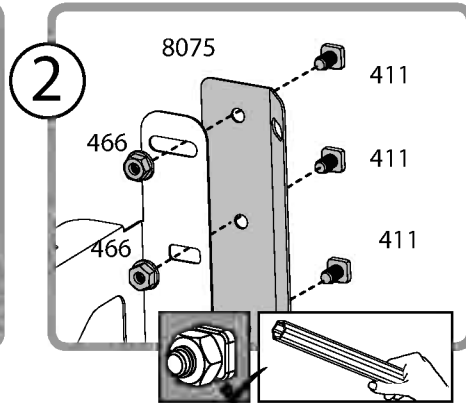
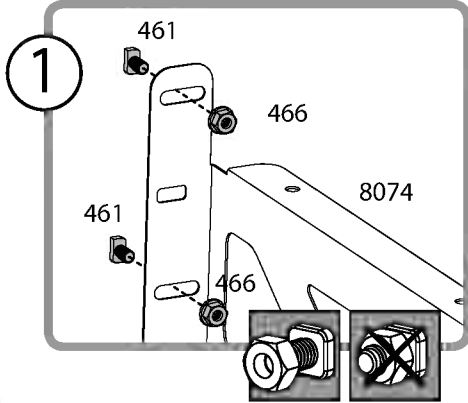
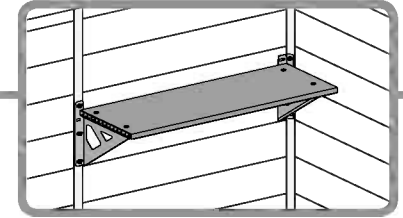



**5** Option #3

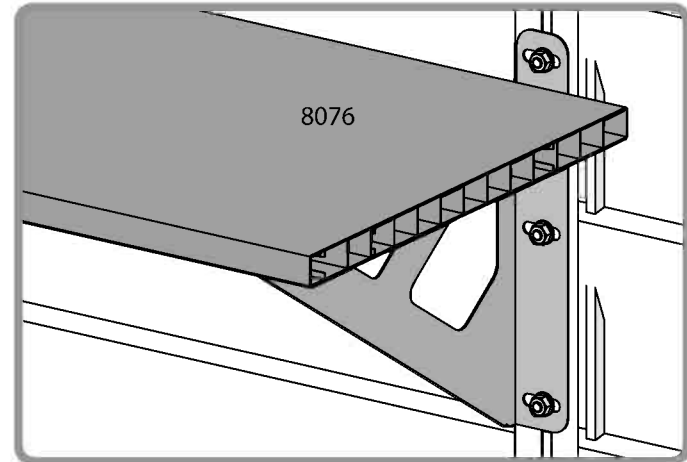
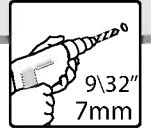
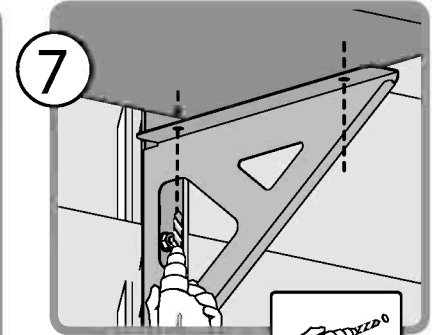
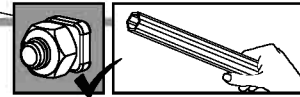
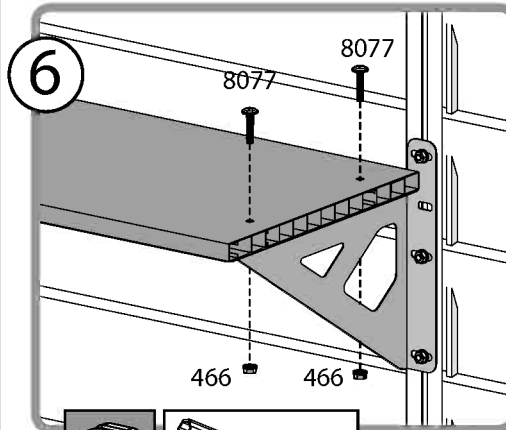
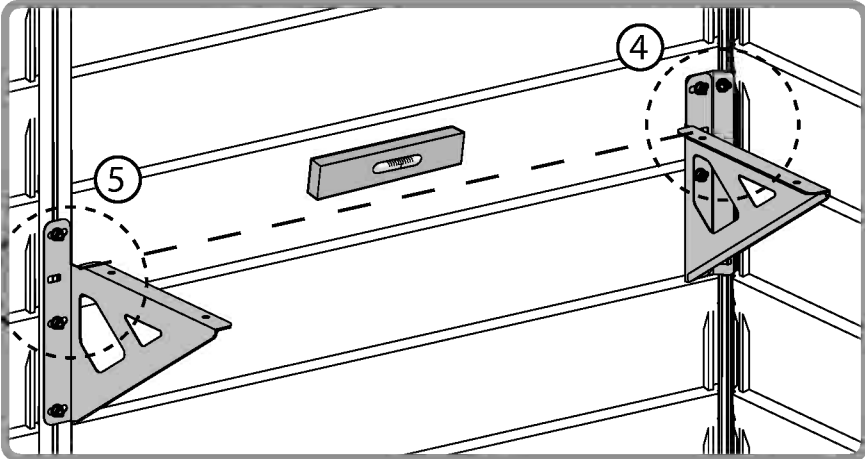
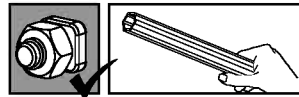
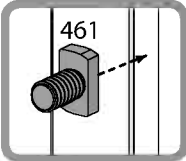
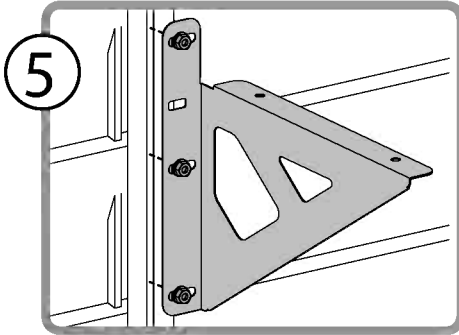
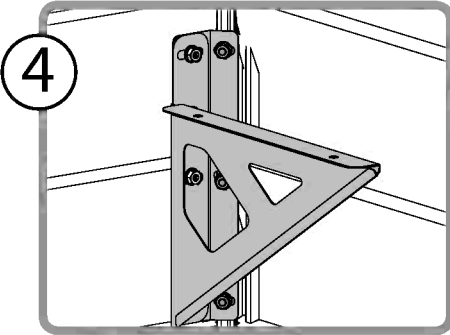
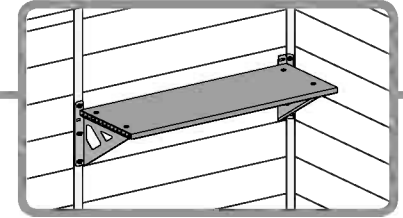

6

Option #4

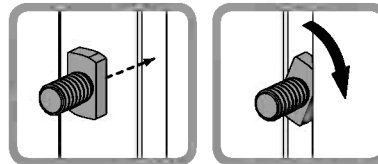
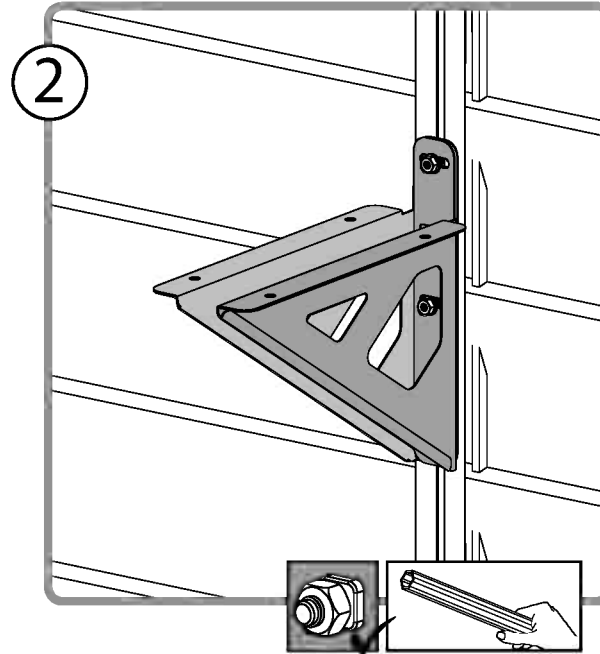
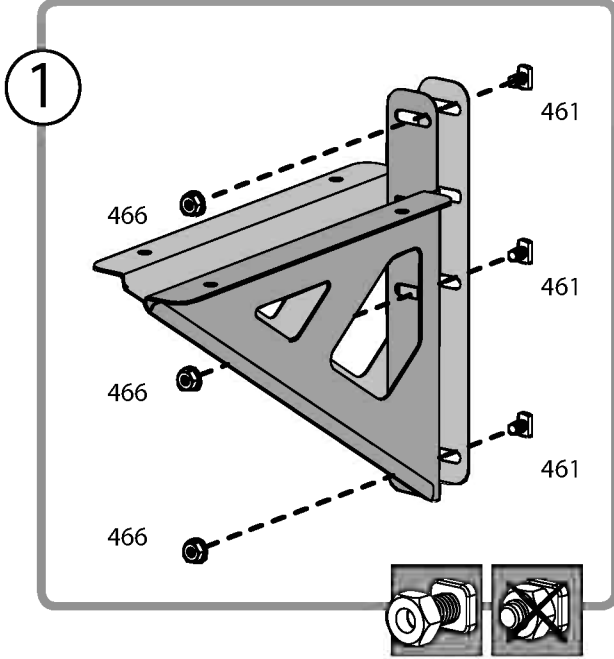
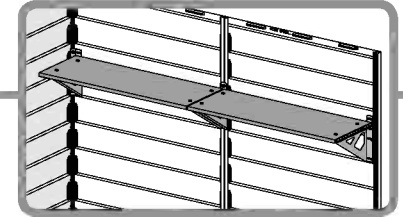

## Contact information

### Head office:

Dancover A/S  
Nordre Strandvej 119 G  
3150 Hellebæk  
Denmark

For more information  
please visit:  
[www.dancovershop.com](http://www.dancovershop.com)

## National contact

Denmark: 70 26 76 20  
[denmark@dancover.com](mailto:denmark@dancover.com)

UK: 020 8099 7570  
[uk@dancover.com](mailto:uk@dancover.com)

Germany: 041 0266 7040  
[germany@dancover.com](mailto:germany@dancover.com)

France: 0975 181 800  
[france@dancover.com](mailto:france@dancover.com)

Sweden: 040 233 262  
[sverige@dancover.com](mailto:sverige@dancover.com)

Finland: 0 931 581 720  
[suomi@dancover.com](mailto:suomi@dancover.com)

Poland: 22 300 8602  
[polska@dancover.com](mailto:polska@dancover.com)

Luxembourg: +49 041 0266 7040  
[luxembourg@dancover.com](mailto:luxembourg@dancover.com)

Portugal: 308 800 899  
[portugal@dancover.com](mailto:portugal@dancover.com)

Spain: 911 436 828  
[espana@dancover.com](mailto:espana@dancover.com)

Italy: 02 479 21 198  
[italia@dancover.com](mailto:italia@dancover.com)

Switzerland: 0840 000125  
[schweiz@dancover.com](mailto:schweiz@dancover.com)

Austria: 0662 626935  
[austria@dancover.com](mailto:austria@dancover.com)

Norway: 231 00 690  
[norge@dancover.com](mailto:norge@dancover.com)

Nederland: 0 858 880 524  
[nederland@dancover.com](mailto:nederland@dancover.com)

Ireland: 0 151 33 003  
[ireland@dancover.com](mailto:ireland@dancover.com)

Belgium: 0 28 08 08 09  
[belgique@dancover.com](mailto:belgique@dancover.com)