



# HOW TO ASSEMBLE

## YUKON™ GARAGE SERIES

11x7 / 3.3x5.2 | 11x21 / 3.3x6.4

### IMPORTANT!

Please read these instructions carefully before starting assembly.  
Keep these instructions in a safe place for future reference.

[www.canopia.com](http://www.canopia.com)



A member of  
Palram Industries Ltd.



11x7 / 3.3x5.2













11x21 / 3.3x6.4

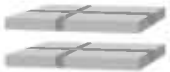
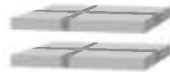



## AVAILABLE MODELS

11x9 / 3.3x2.7		11x13 / 3.3x3.4		11x17 / 3.3x5.2		11x21 / 3.3x6.4	
							
<b>PRIMARY UNIT</b> 11x9 / 3.3x2.7	<b>2 BOXES</b> 	<b>PRIMARY UNIT</b> 11x9 / 3.3x2.7	<b>2 BOXES</b> 	<b>PRIMARY UNIT</b> 11x9 / 3.3x2.7	<b>2 BOXES</b> 	<b>PRIMARY UNIT</b> 11x9 / 3.3x2.7	<b>2 BOXES</b> 
		<b>1 EXTENSION UNIT</b> 11x4 / 3.3x0.4	<b>1 BOX</b> 	<b>2 EXTENSION UNITS</b> 11x4 / 3.3x0.4	<b>2 BOXES</b> 	<b>3 EXTENSION UNITS</b> 11x4 / 3.3x0.4	<b>3 BOXES</b> 
				<b>REINFORCEMENT KIT</b> 3 pcs	<b>1 BOX</b> 	<b>REINFORCEMENT KIT</b> 4 pcs	<b>1 BOX</b> 



## 4 WAYS TO WATCH OUR VIDEO



### 1 Scan QR Code



### 2 Search on YouTube



Palram - Canopia  
YUKON Assembly



### 3 Go to

<https://bit.ly/3C1oL5R>

### 4 Visit us

<https://canopia.com/product/yukon-11ft-garage-shed/>



# WE´VE GOT YOU COVERED

NOUS NOUS OCCUPONS DE VOUS | NOS OCUPAMOS DE UD | WIR HELFEN IHNEN GERNE

**EN** Our self-service form makes it convenient and fast. Go to the URL below or scan the QR code with your phone to submit you request.

**FR** Notre formulaire en ligne est pratique et rapide. Rendez vous sur l'URL ci-dessous ou scannez le code QR avec votre téléphone pour soumettre votre demande.

**ES** Nuestro formulario de autoservicio lo hace conveniente y rápido. Vaya al URL de abajo o escanee el código QR con su teléfono para enviar su solicitud.

**DE** Nutzen Sie schnell und bequem unser Kontaktformular. Rufen Sie die untenstehende URL auf oder scannen Sie den QR-Code mit Ihrem Handy, um Ihre Anfrage zu übermitteln.

## Missing a part or need a new one?

Il vous manque une pièce ou vous avez besoin d'une piece supplémentaire?  
Me falta una pieza o necesito una nueva?  
Fehlt ein Teil oder benötigen Sie ein Ersatzteil?



SCAN ME

[canopia.shop/part\\_request](https://canopia.shop/part_request)

## Need help assembling your product?

Besoin d'aide pour monter votre produit?  
Necesito ayuda para montar mi producto?  
Benötigen Sie Hilfe bei der Montage Ihres Produkts?



SCAN ME

[canopia.shop/support](https://canopia.shop/support)



SCAN ME

# WE ARE HERE TO HELP

For general questions: [canopia.com/contact-us](https://canopia.com/contact-us)

USA	
	877-627-8476
	hobbyservice@poly-tex.com

CANADA	
	905-5646007
	sales@footprintproducts.com

UNITED KINGDOM · IRELAND	
	01302-380775
	customer.serviceUK@palram.com

GERMANY	
	0180-522-8778
	customer.serviceDE@palram.com

FRANCE · BELGIUM	
	+33-169-791-094
	customer.serviceFR@palram.com

ISRAEL	
	04-848-6816
	customer.service@palram.com

ITALY · NETHERLANDS · PORTUGAL · SPAIN	
	+33-169-791-094
	customer.serviceFR@palram.com

AUSTRIA · LUXEMBURG · LIECHTENSTEIN	
	+49-180-522-8778
	customer.serviceDE@palram.com

AUSTRALIA	
	03-9219-4444
	salesvic@palram.com

NORWAY · SWEDEN · ARGENTINA · GREECE · GREENLAND · ICELAND · ESTONIA · JAPAN · LATVIA · LITHUANIA  
 MAURITIUS · MEXICO · ROMANIA · RUSSIA · TURKEY · UZBEKISTAN · UKRAINE · SWAZILAND · KOREA

	+972-4-848-6816
	customer.service@palram.com



## CUSTOMER SUPPORT





SCAN ME

# WE ARE HERE TO HELP

For general questions: [canopia.com/contact-us](https://canopia.com/contact-us)

### AUSTRALIA - GREENHOUSES

 03-9544-6-999

 [info@mazedistribution.com.au](mailto:info@mazedistribution.com.au)

### HUNGARY · SLOVAKIA

 +420-493-523-523

 [servis@garland.cz](mailto:servis@garland.cz)

### NEW ZEALAND

 0800 800 880

 [customer.service@palram.com](mailto:customer.service@palram.com)

### DENMARK

 07-575 42 70

 [post@nshnordic.com](mailto:post@nshnordic.com)

### SOUTH AFRICA

 011-397-7771

 [receptionza@palram.com](mailto:receptionza@palram.com)

### CROATIA · SLOVENIA

 0599-37-057

 [info@ms-viscom.com](mailto:info@ms-viscom.com)

### CZECH REPUBLIC

 0493-523-523

 [servis@garland.cz](mailto:servis@garland.cz)

### FINLAND

 Neuvonta: 09-6866720  
Tuki / Varaosat: 050-3715350

 [www.horisontenterprises.fi](http://www.horisontenterprises.fi)  
[tuki@horisontenterprises.fi](mailto:tuki@horisontenterprises.fi)

### POLAND

 Infolinia: 801-011-929  
22-349-93-36

 [kontakt@ogrodosfera.pl](mailto:kontakt@ogrodosfera.pl)

### CYPRUS

 0224-971-13

 [alpaco@alpacodomica.com](mailto:alpaco@alpacodomica.com)  
[www.alpacodomica.com](http://www.alpacodomica.com)

### SWITZERLAND

 062-287-33-77

 [info@ritter.ch](mailto:info@ritter.ch)



## BASE DIMENSIONS YUKON GARAGE GARDEN SHED

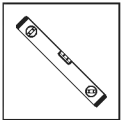
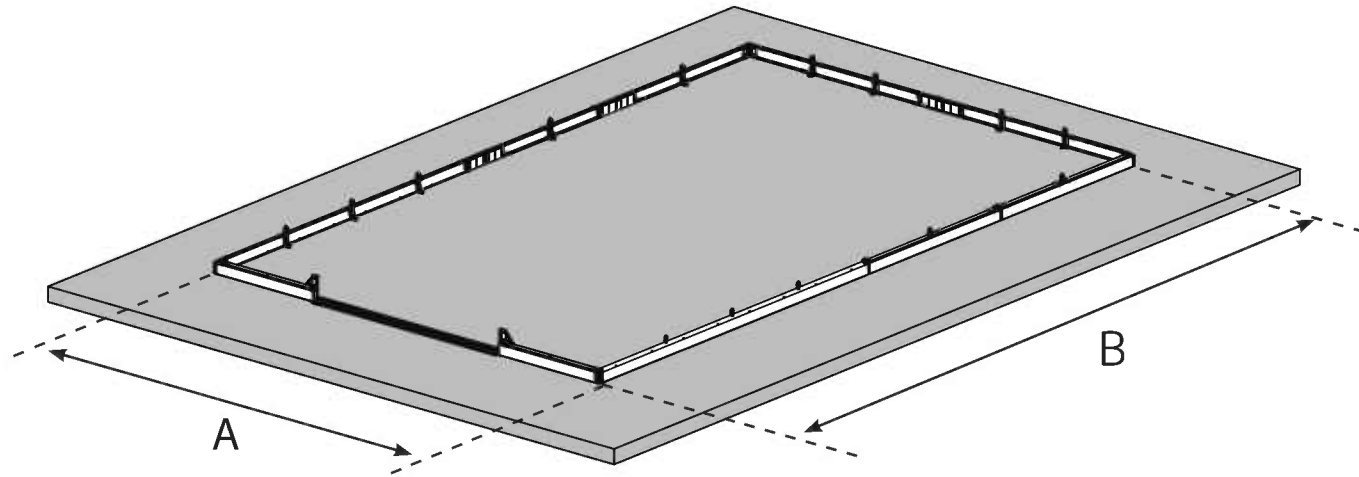

MODEL	WIDTH		LENGTH	
11x17 / 3.3x5.2	A	307 cm / 121"	B	508 cm / 200"
11x21 / 3.3x6.4		307 cm / 121"		633 cm / 249"

## SITE PREPARATION & FOUNDATION

### A - PREPARE THE SITE

The product must be built on a **solid and leveled** surface in order to perform properly.

#### 1 - Clear the site

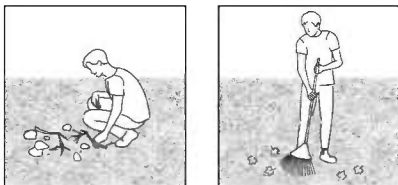

#### 2 - Level the ground

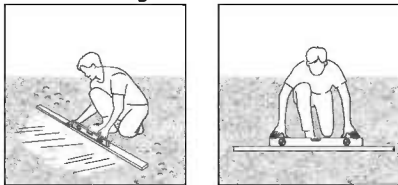

### IMPORTANT

We recommend checking for restrictions or covenants for building this product in your area. In addition we advise to check if you need to submit any forms or if any permit is required prior to building the product.

### B - CHOOSE YOUR FOUNDATION TYPE

For a base, we recommend using three material types :  
Concrete | Pressure treated wood / wood deck | Paver blocks

#### Solid base

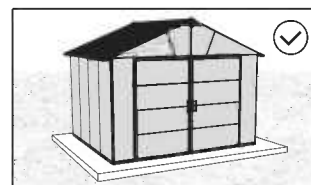
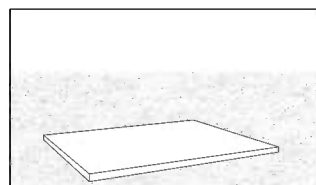

Not possible

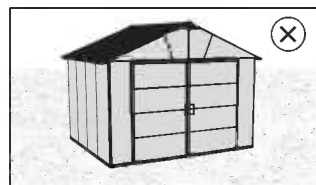

Not possible

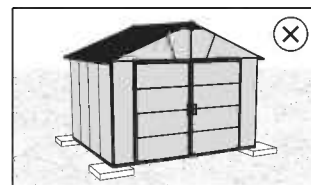

\* The size of the product displayed is for illustration purposes only and may not reflect the size of your product.

### C - ANCHOR TO FOUNDATION

#### On a solid base

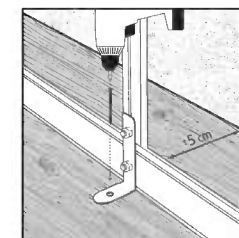
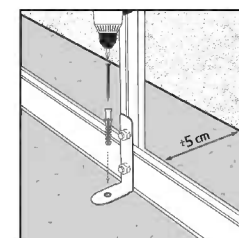

Secure the product to the foundation of your choice using suitable screws & plugs or masonry anchors (not supplied).

Make sure you have at least 5 cm | 2" between the product base and the edges of your foundation - **on all sides.**

## OPTIONAL ACCESSORIES



#### WPC Floor Kit:

If you've purchased the WPC Floor Kit with the product, relevant steps are marked with these icons. If you've assembled the product without the floor kit and wish to add one, please refer to the relevant steps (marked with these icons) in the assembly and perform the necessary adjustments.



#### Utility Shed Shelf Kit:

If you've purchased shelf kits, it is recommended to insert screws #411 inside the profiles' tracks during the walls' assembly.

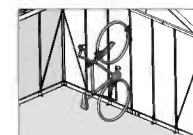

#### Vertical Bicycle Hanger:

Can be installed once the product is fully assembled. Make sure the bottom wheel is at floor level.



## SAFETY ADVICE

- It is of utmost importance to assemble all of the parts according to the directions. Do not skip any steps.
- We strongly recommend using work gloves during panel sliding.
- Always wear shoes and safety goggles when working with extruded aluminium.
- If using a step ladder or power tools make sure that you follow the manufacturer's safety advice.
- Do not touch overhead power cables with the aluminium profiles.
- Do not attempt to assemble the product in windy or wet conditions.
- Dispose of all plastic bags. Keep them out of reach of small children.
- Keep children away from the assembly area.
- Do not lean against or push the products during construction.
- Do not position your product in an area exposed to excessive winds.
- Do not attempt to assemble this product if you are tired, have taken drugs or alcohol or if you are prone to dizzy spells.
- Hot items such as recently used grills, blowtorches etc. must not be stored in the product.
- Make sure there are no hidden pipes or cables in the ground before anchoring to foundation.
- This product is designed to be used mainly as a garden shed.
- To prevent water from seeping through the floor, the product must be mounted on a raised surface from the ground.
- **Make sure to anchor the product directly to a solid foundation to increase the product's stability and wind resistance in areas with severe weather conditions. Make sure that there are no obstructions between the assembly area and the final position of the product. The Palram - Canopia Anchoring kit is available for purchase separately.**

## CARE & MAINTENANCE

- When your product needs to be cleaned, use a mild detergent solution and rinse with cold clean water.
- DO NOT use acetone, abrasive cleaners or other special detergents to clean the panels.
- Clean the product once assembly is complete.

## TOOLS & EQUIPMENT

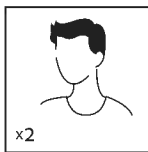

2 people needed

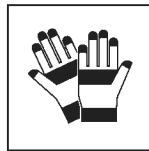

Work gloves

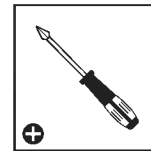

Philips head Screwdriver

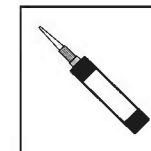

Silicone

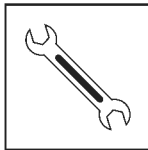

Wrench  
10 mm | 13/32"

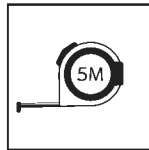

Tape Measure

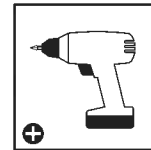

Cordless drill  
Phillips head

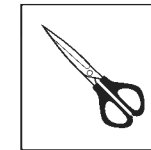

Scissors



Soap



Ladder

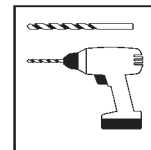

Cordless drill  
With Drill Bit

## BEFORE ASSEMBLY

1. Selecting a site:
  - Choose your site carefully before beginning assembly.
  - Choose a sunny position away from overhanging trees.
  - The product must be positioned and fixed on a flat level surface.
2. The product must be secured directly to a solid foundation.
3. This is a multi-part assembly best achieved by two people. Allow at least half a day for the assembly process.
4. Take all components & parts out of the packages. Sort the parts and check against the content parts list.
5. Parts should be laid out close at hand. Keep all small parts (screws etc.) in a bowl so they do not get lost.
6. Please note multi-sided profiles are used in this product. As a result some holes in the profiles are not used during assembly.
7. Please review entire instructions before starting. Carry out the assembly steps in exact order.
8. Please consult your local authorities if any permits are required prior to constructing the product.
9. Please ensure you have sufficient side space for inserting the roof panels during the assembly process.

## IMPORTANT!

- Firmly connect the product to a level surface immediately after completion of the assembly.
- Anchoring this product to the ground is essential to its stability and rigidity. It is required to complete this stage in order for your warranty to be valid.
- During assembly use a soft surface below the parts to avoid scratches and damages.
- The drawings in this manual are designed for products 11x17 / 3.3x5.2 & 11x21 / 3.3x6.4.

## DURING ASSEMBLY

- During assembly, you will encounter different icons for different products. Please see below for more information:



- During assembly you will encounter the information icon, please refer to the relevant assembly step for additional comments and assistance.



- You may use silicone lubricant spray on the frame in order to help you slide the panels into the profiles. Do not spray the panels.



- Use a rubber mallet if necessary.

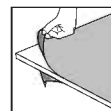

- Make sure you remove covering plastic film from both sides of the panel.

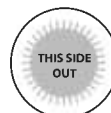

- All panels with the stamped words "THIS SIDE OUT" must be facing out to create full UV protection. Remove plastic sticker as panels are locked in place.



- This icon indicates that the installer should be inside the product.



- This icon indicates that the installer should be outside the product.

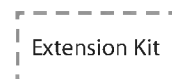

- Steps marked with dashed outlines refer to Extensions only.
- Some of the steps are irrelevant for an assembly of a single product.
- When assembling a single or an extended product, some parts may be surplus.

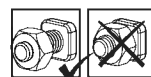

- These 2 icons below indicate if screw's tightening is required or not.
- Temporary tightening of a few screws may be needed to prevent a profile from sliding out.



- Tighten all screws once assembly is completed.



## IMPORTANT ASSEMBLY STEPS

**When encountering this information icon during assembly, please refer to the relevant assembly step for important additional comments.**

- Step 15:** Matte side of all product's panels should be facing out!  
Use mild soap if needed to ease sliding of profiles & panels.
- Step 19:** It is recommended to insert screws #8192 as preparation for mounting shelves.  
If you've purchased a **Utility Shed Shelf kit**, mount a maximum of 2 shelves per post.
- Step 24:** Note the bracket's direction as shown in the drawings, make sure the bracket is in line with the gutter profile.
- Step 26:** Note the bracket's direction and make sure the screws are positioned inside the profile's channels as shown in the drawings.
- Step 27:** It is recommended to insert screws #8192 as preparation for mounting shelves.  
If you've purchased a **Utility Shed Shelf kit**, mount a maximum of 2 shelves per post.
- Step 31:** If you've purchased the **Yukon 11x21 / 3.3x6.4 Storage Shed**, please continue building the walls, adding the additional bracket and inserting screws #8192 as preparation for mounting shelves, as you've done in the last 4 steps.

- Step 32:** It is recommended to insert screws #8192 as preparation for mounting shelves.  
If you've purchased a **Utility Shed Shelf kit**, mount a maximum of 2 shelves per post.
- Steps 39+40:** Before inserting the screws, make sure the internal metal profiles are not protruding and are well connected with one another inside the aluminum profiles.
- Step 43:** The sticker must be placed on a clean and dry surface.
- Step 52:** Slow down and be careful when sliding the panels in.
- Step 55:** Make sure the distance between the wall's aluminum profiles and gutter is identical prior to tightening the screws on the inside.
- Step 72:** Make sure the shed is leveled prior to anchoring it to the surface of your choosing.  
Use suitable screws and plugs (not supplied).

## PRÉPARATION DU TERRAIN ET FONDATION

### A- PRÉPARER LE TERRAIN

Le produit doit être monté sur une **surface solide et nivelée** afin d'en assurer la bonne stabilité.

#### 1- Déblayer le terrain

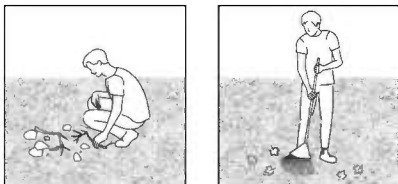

#### 2- Nivelier le sol

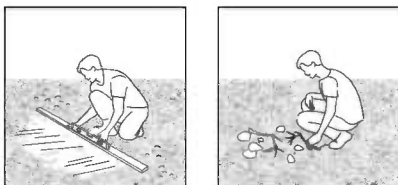

### IMPORTANT

Avant d'assembler ce produit dans votre région, nous vous recommandons de vous renseigner sur les restrictions ou réglementations locales. Nous vous conseillons en outre de vérifier si vous devez soumettre des formulaires ou si un permis est requis avant de monter le produit.

### B - CHOISIR VOTRE TYPE DE FONDATION

Pour la base, nous recommandons d'utiliser trois types de matériaux :  
Béton | Bois traité sous pression / plancher en bois | Blocs de pavés.

#### Une base solide

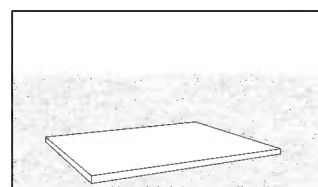

Recommandé

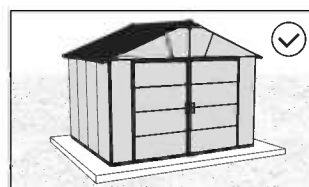

Pas possible

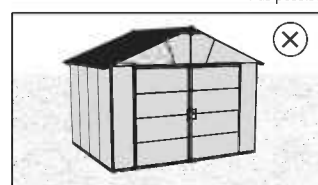

Pas possible

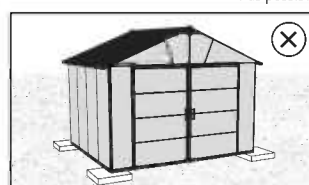

\* La taille de la produit affichée ici est uniquement à titre d'illustration et ne reflète pas forcément la taille de votre produit.

### C - ANCRAGE A LA FONDATION

#### Sur une base solide

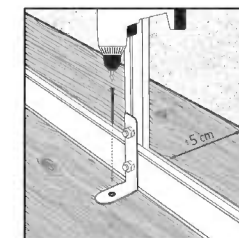
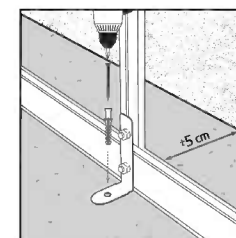

Fixez le produit à la fondation de votre choix, à l'aide de vis et de chevilles appropriées ou d'ancrages en maçonnerie (non fournis).

Assurez-vous qu'il y a au moins 5 cm entre la base du produit et le périmètre de votre fondation - **de tous les côtés.**

## ACCESSOIRES OPTIONNELS



#### WPC Floor Kit:

Si vous avez acheté le sol en **kit avec** le produit, les étapes correspondantes sont symbolisées par cette icône. Si vous avez assemblé le produit sans sol en kit, et souhaitez en ajouter un, veuillez-vous reporter aux étapes appropriées du montage et effectuer les ajustements nécessaires.



#### Kit de étagère:

Si vous avez acheté des kits de étagère, il est recommandé d'insérer des vis **#411** à l'intérieur des rails des profilés lors de l'assemblage des murs.

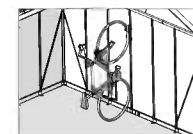

#### Cintre à bicyclette verticale:

Peut être installé une fois que le produit est complètement assemblé. Assurez-vous que la roue inférieure est au niveau du sol.

## CONSEILS DE SECURITE

- Très important ! Veuillez suivre scrupuleusement les instructions de ce manuel et réaliser les étapes dans l'ordre énoncé.
- Nous recommandons vivement le port de gants de protection pendant le montage.
- Portez toujours des chaussures de travail et des lunettes de protection lorsque vous travaillez des pièces en aluminium extrudé.
- Lors de l'utilisation d'une échelle ou d'outils électriques, assurez-vous de bien suivre les consignes de sécurité du fabricant.
- Veillez à ne pas toucher de câbles aériens avec les profilés en aluminium.
- N'essayez pas de monter la produit s'il y a du vent ou s'il fait humide.
- Jetez tous les sacs en plastique en appliquant les règles de sécurité et maintenez-les hors de portée des jeunes enfants.
- Eloignez les enfants de la zone d'assemblage.
- Ne vous appuyez pas contre la produit et ne la poussez pas pendant le montage.
- Ne positionnez pas la produit dans un endroit trop exposé au vent.
- N'essayez pas de monter la produit si vous êtes fatigué, si vous êtes sous l'effet de drogues, de médicaments ou d'alcool ou encore si vous êtes sujet aux vertiges.
- Les objets chauds tels qu'un barbecue, un chalumeau ou autre article ayant été récemment utilisés, ne doivent pas être rangés dans la produit.
- Assurez-vous qu'il n'y a pas de tuyaux ou de câbles cachés dans le sol avant d'ancrer à la fondation.
- Ce produit a été conçu pour être principalement utilisé comme abris de jardin.
- Pour éviter que beau ne s'infiltre par le sol, le produit doit être monté sur une surface surélevée par rapport au sol.
- **Assurez-vous d'ancrer le produit directement sur une surface solide pour augmenter sa stabilité et sa résistance au vent, en particulier dans les zones soumises à des conditions météorologiques extrêmes. Veillez à ce qu'il n'y ait pas d'obstacles entre la zone de montage et la position finale du produit. Le kit d'ancrage Palram - Canopia est disponible à l'achat séparément.**

## ENTRETIEN & MAINTENANCE

- Pour nettoyer votre produit, utilisez une solution détergente douce et rincez à l'eau claire et froide.
- NE PAS utiliser d'acétone ni de produits nettoyants ou autres détergents spéciaux pour nettoyer les panneaux clairs.
- Nettoyez le produit une fois le montage termine.

## OUTILS ET ÉQUIPEMENT

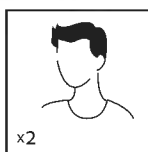

- Nécessite 2 personnes

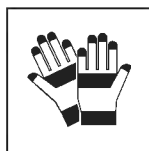

- Gants de travail



- Tournevis cruciforme



- Silicone

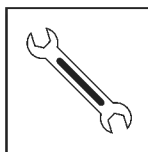

- Clé 10 mm | 13/32"

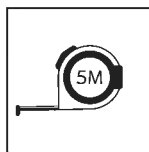

- Mètre

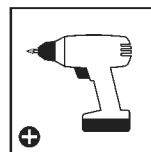

- Perceuse - Tête Philips

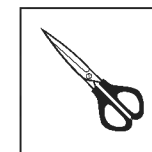

- Ciseaux



- Savon liquide



- Echelle

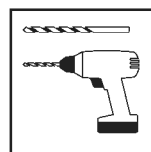

- Perceuse avec foret

## AVANT L'ASSEMBLAGE

- Choisir un endroit :
  - Choisissez votre site avec soin avant de commencer l'assemblage.
  - Choisissez un endroit ensoleillé loin des arbres en saillie.
  - La produit doit être positionnée et fixée sur une surface plane.
- Le produit doit être fixé directement sur une surface solide
- Il s'agit d'un assemblage multi parties qu'il vaut mieux réaliser à deux.  
Comptez au moins une demi journée pour le processus de montage.
- Retirez tous les composants des paquets. Triez les éléments et vérifiez la liste.
- Les éléments doivent se trouver à portée de main. Gardez tous les petits éléments (vis etc.) dans un bol pour ne pas les perdre.
- Veillez noter que des coupes multi faces sont utilisées dans cette produit.  
C'est pourquoi certains trous dans les coupes ne sont pas utilisés pendant le montage.
- Veillez vérifier toutes les instructions avant de commencer.  
Procédez aux étapes de montage dans l'ordre exact.
- Veillez consulter les autorités locales au cas où des permis sont nécessaires pour la construction du produit.
- Veillez vous assurer que vous disposez d'un espace latéral suffisant pour insérer les panneaux de toit pendant le processus d'assemblage.

## IMPORTANT!

- Connectez du produit fermement à une surface nivelée après l'achèvement de l'assemblage.
- L'ancrage du produit au sol entielle à sa stabilité et à sa rigidité, il est de plus nécessaire pour assurer la validité de votre garantie.
- Pendant le montage, placez une surface souple sous les pièces pour éviter de les érafler ou de les endommager.
- Les dessins de ce manuel correspondent à un produit 11x17 / 3.3x5.2 & 11x21 / 3.3x6.4.

## DURANT L'ASSEMBLAGE

- Lors du montage, vous trouverez différentes icônes correspondant à différents produits. Pour de plus amples informations, veuillez vous référer à ce qui suit:



- Pendant le montage, vous verrez l'icône d'information, veuillez-vous référer à la phase de montage correspondante pour des commentaires et une assistance supplémentaires.



- Vous pouvez utiliser un spray de lubrifiant pour silicone afin de vous aider à glisser les panneaux dans les profilés. Ne pulvérisez pas les panneaux.



- Utilisez un maillet en caoutchouc si nécessaire.

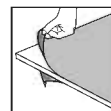

- Assurez-vous de retirer le film plastique couvrant des deux côtés du panneau.

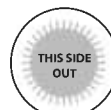

- Tous les panneaux estampillés "THIS SIDE OUT" doivent être orientés vers l'extérieur pour assurer une protection UV intégrale. Retirez les stickers en plastique quand les panneaux sont verrouillés et bien en place.



- Cette icône indique que l'installateur doit être à l'intérieur du produit.



- Cette icône indique que l'installateur doit être en dehors du produit.

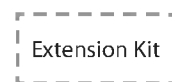

- Les étapes marquées en pointillés ne concernent que les extensions.
- Certaines étapes ne sont pas nécessaires pour l'assemblage d'un produit unique.
- Lors de l'assemblage d'un produit unique ou d'une extension, il peut rester des pièces.

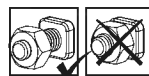

- Ces 2 icônes indiquent s'il est nécessaire de serrer les écrous ou non.
- Il peut être nécessaire de serrer temporairement certaines vis pour empêcher un profilé de se déplacer.

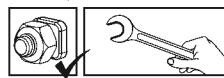

- Serrez toutes les vis une fois l'assemblage terminé.



## PRINCIPALES ÉTAPES D'ASSEMBLAGE

Lorsque vous rencontrez cette icône d'information pendant l'assemblage, veuillez vous référer à l'étape d'assemblage correspondante pour d'autres commentaires importants.

- Étape 15:** Le côté mat de tous les panneaux du produit devrait être tourné vers l'extérieur !  
Utilisez un savon doux si nécessaire pour faciliter le glissement des profilés et des panneaux.
- Étape 19:** Il est recommandé d'insérer les vis #8192 comme préparation pour les tablettes de montage.  
Si vous avez acheté un **kit d'étagère**, montez un maximum de 2 étagères par poste.
- Étape 24:** notez la direction du support comme indiqué sur les dessins et assurez-vous que le support est bien aligné avec le profil de gouttière.
- Étape 26:** notez la direction du support et assurez-vous que les vis sont bien placées à l'intérieur des canaux du profilé, comme indiqué sur les dessins.
- Étape 27:** Il est recommandé d'insérer les vis #8192 comme préparation pour les tablettes de montage.  
Si vous avez acheté un **kit d'étagère**, montez un maximum de 2 étagères par poste.

- Étape 31:** si vous avez acheté le hangar de stockage **Yukon 11x21 /3.3x6.4** veuillez compléter de construire les murs en ajoutant le support supplémentaire et en insérant les vis #8192 en guise de préparation pour le montage des étagères, comme vous l'avez fait lors des 4 dernières étapes.
- Étape 32:** Il est recommandé d'insérer les vis #8192 comme préparation pour les tablettes de montage.  
Si vous avez acheté un **kit d'étagère**, montez un maximum de 2 étagères par poste.
- Étapes 39+40:** Avant d'insérer les vis, assurez-vous que les profilés métalliques internes ne dépassent pas et sont bien connectés les uns aux autres à l'intérieur des profilés d'aluminium.
- Étape 43:** L'autocollant doit être placé sur une surface propre et sèche.
- Étape 52:** Ralentissez et faites attention lorsque vous y glissez les panneaux.
- Étape 55:** Assurez-vous que la distance entre les profilés d'aluminium du mur et la gouttière est identique avant de serrer les vis à l'intérieur.
- Étape 72:** Assurez-vous que l'abri de jardin est nivelé avant de l'ancre sur la zone de votre choix.

## STANDORTWAHL & FUNDAMENT

### A - VORBEREITUNG DES UNTERGRUNDES

Das Produkt muss auf einem **festen und absolut ebenmäßigen** Untergrund aufgebaut werden, um eine einwandfreie Funktion zu gewährleisten.

#### 1 - Standort säubern

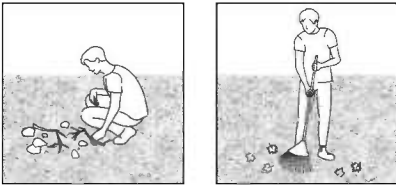

#### 2 - Untergrund ausgleichen und nivellieren

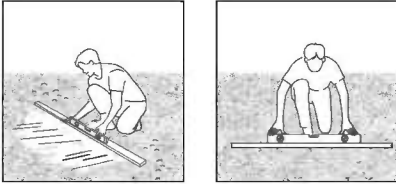

### WICHTIG

Bevor Sie mit der Montage beginnen, vergewissern Sie sich bitte beim zuständigen Bauamt, ob es in Ihrer Region Einschränkungen oder Auflagen für den Bau des gewählten Produktes gibt. Wir bitten Sie außerdem zu prüfen, ob eine Genehmigung für den Bau erforderlich ist.

### B - FUNDAMENTWAHL

Als Untergrund stehen folgende Materialien zur Auswahl (Empfehlung):  
Beton | Druckbehandeltes Holz/Holzdeck | Pflastersteine

#### Fester Untergrund

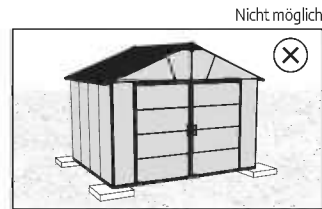
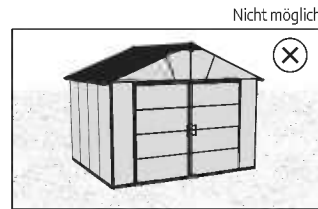
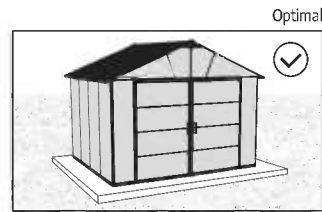
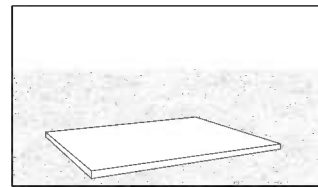

\* Die Größe des abgebildeten Produkt dient nur zur Veranschaulichung und entspricht möglicherweise nicht der Größe Ihres Produkt.

### C - BEFESTIGUNG AM FUNDAMENT

#### Befestigen Sie das Produkt auf einem festen Untergrund

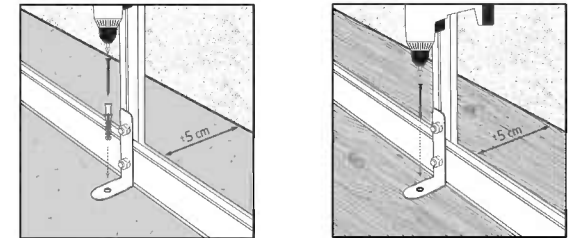

Mit geeigneten Dübeln und Schrauben oder Mauerwerksankern, je nach gewähltem Fundamenttyp (nicht mitgeliefert).

Stellen Sie sicher, dass zwischen der Basis des Produkts und den Kanten Ihres Fundaments auf allen Seiten mindestens 5 cm Abstand sind.

## OPTIONALES ZUBEHÖR



WPC Floor Kit



Floor Extension Kit

#### WPC Floor Kit:

Wenn Sie auch das **Boden-Set** mit dem Produkt gekauft haben, sind die entsprechenden Schritte mit diesem Symbol gekennzeichnet. Wenn Sie das Produkt ohne dem Bodenset montiert haben und es später hinzufügen möchten, so beachten Sie bitte die entsprechenden Schritte in der Montage und führen Sie die notwendigen Änderungen durch.

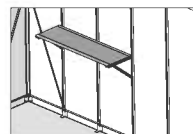

#### Regal Kit:

Wenn Sie Regal Kits gekauft haben, wird empfohlen, die Schrauben **Nr. 411** während der Wandmontage in die Innenseite der Schienen-Profile einzusetzen.

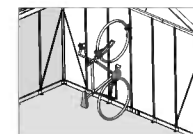

#### Vertikale Fahrradhalterung:

Kann erst installiert werden, wenn das Produkt vollständig montiert ist. Vergewissern Sie sich, dass sich das untere Rad auf Bodenhöhe befindet.



## SICHERHEITSHINWEISE

- Es ist sehr wichtig, dass alle Teile gemäß den Anweisungen in dieser Anleitung zusammengebaut werden. Lassen Sie bitte keinen Schritt aus.
- Tragen Sie bei der Montage unbedingt Arbeitshandschuhe. Wir empfehlen Ihnen außerdem dringend, festes Schuhwerk und eine Schutzbrille zu tragen.
- Achten Sie beim verwenden einer Leiter oder Elektrowerkzeug bitte auf die jeweiligen Sicherheitshinweise des Herstellers.
- Berühren Sie mit den Aluminiumprofilen keine Oberleitungen.
- Halten Sie Kinder vom Aufbaubereich fern.
- Die Montage darf nur bei trockenem und windstillem Wetter erfolgen.
- Entsorgen Sie alle Plastikbeutel sicher und bewahren sie außerhalb der Reichweite von Kleinkindern auf.
- Während des Aufbaus sollten Sie sich nicht gegen das Produkt lehnen oder Druck ausüben.
- Suchen Sie einen windgeschützten Standort für das Produkt aus.
- Versuchen Sie nicht, dieses Produkt zu montieren, wenn Sie müde sind, Drogen oder Alkohol zu sich genommen haben oder zu Schwindelanfällen neigen.
- Heiße Gegenstände wie kürzlich benutzte Grills, Lötlampen usw. dürfen nicht im Produkt gelagert werden.
- Bevor Sie das Produkt im Fundament verankern, vergewissern Sie sich, dass sich dort keine versteckten Rohre oder Kabel befinden.
- Dieses Produkt ist hauptsächlich für die Verwendung als Gerätehäuser vorgesehen.
- Um zu verhindern, dass Wasser durch den Boden sickert, muss das Produkt auf einer vom Boden etwas erhöhten Fläche montiert werden.
- **Um die Stabilität und Windbeständigkeit des Produkts zu erhöhen, müssen Sie es direkt auf einem soliden Fundament verankern, insbesondere in solchen Gegenden, in denen die Witterungsbedingungen streng sind. Stellen Sie sicher, dass sich keine Hindernisse zwischen dem Montagebereich und der endgültigen Position des Produkts befinden. Der Palram - Canopia - Verankerungssatz kann separat erworben werden.**

## PFLEGE & WARTUNG

- Zur Reinigung verwenden Sie ein mildes Reinigungsmittel und spülen es mit kaltem, sauberem Wasser nach.
- Verwenden Sie zur Reinigung der Paneele KEIN Aceton und auch keine scheuernden Reinigungsmittel oder Spezialreiniger.
- Säubern Sie das Produkt nach dem Aufbau.

## WERKZEUGE & AUSTRÜSTUNG

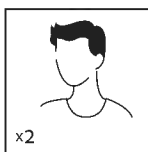

- Zwei Personen erforderlich

x2

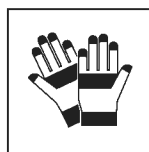

- Arbeitshandschuhe

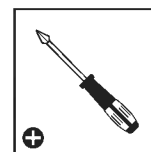

- Kreuzschlitzschraubendreher

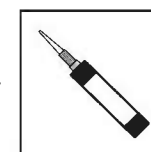

- Silikon

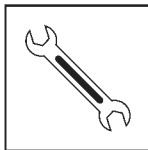

- Schraubenschlüssel  
10 mm | 13/32"

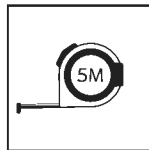

- Maßband

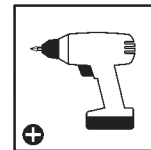

- Akkuboherer -  
Kreuzschlitzaufsatz

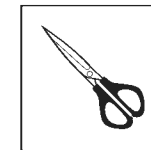

- Schere



- Flüssige Seife



- Leiter

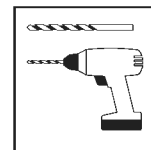

- Akkuboherer - mit Bohrer

## VOR DEM ZUSAMMENBAU

- Die Standortwahl:
  - Wählen Sie Ihren Standort sorgfältig, bevor Sie mit dem Aufbau beginnen.
  - Das Produkt muss auf einem flachen Untergrund aufgestellt und befestigt werden.
  - Wählen Sie eine Position abseits von überhängenden Bäumen.
- Das Produkt muss direkt auf einem festen Untergrund befestigt werden.
- Für die Montage dieses Produktes sind zwei Personen erforderlich. Sie sich für den Zusammenbau mindestens einen halben Tag Zeit.
- Packen Sie die Bauteile aus und überprüfen Sie, ob alle Teile der Liste aufgeführt sind.
- Die Teile sollten griffbereit ausgelegt werden. Bewahren Sie alle kleinen Teile (Schrauben usw.) in einer Schüssel auf, damit nichts verloren geht.
- Beachten Sie bitte, dass bei diesem Produkt mehrseitige Profile verwendet werden. Während des Zusammenbaus sind daher nicht alle Löcher in den Profilen relevant.
- Lesen Sie vor Beginn des Aufbaus die gesamte Anleitung durch. Führen Sie die Montageschritte in genauer Reihenfolge durch.
- Fragen Sie bei den örtlichen Behörden nach, ob es irgendwelche Einschränkungen für den Aufbau gibt oder Genehmigungen erforderlich sind.
- Bitte stellen Sie sicher, dass Sie zum Einfügen der Dachplatten während des Montageprozesses ausreichend Seitenraum haben.

## WICHTIG!

- Befestigen Sie das Produkts sofort nach Fertigstellung der Montage auf einem ebenen Untergrund.
- Die Verankerung dieses Produkts im Boden ist für seine Stabilität und Standfestigkeit unerlässlich. Eine ordentlich Befestigung ist erforderlich, damit die Garantie gültig ist.
- Legen Sie während des Aufbaus eine weiche Unterlage unter die einzelnen Teile, um Kratzer und Schäden zu vermeiden.
- Die Zeichnungen in diesem Handbuch beziehen sich für den 11x17 / 3.3x5.2 & 11x21 / 3.3x6.4 Schuppen.

## WÄHREND DER MONTAGE

- Während der Montage werden Sie verschiedene Symbole für unterschiedliche Produkte sehen. Weitere Informationen finden Sie unten:



- Während der Montage begegnet Ihnen das Informationssymbol, weitere Hinweise und Hilfestellungen finden Sie auf der Seite "WICHTIGE MONTAGESCHRITTE".



- Sie können Silikonschmierspray auf den Rahmen sprühen, um das Einschieben der Platten in die Profile zu erleichtern. Besprühen Sie nicht die Platten.

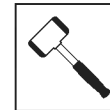

- Nehmen Sie – falls nötig – einen Gummihammer zur Hilfe.

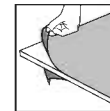

- Sie die abdeckende Kunststoffolie von beiden Seiten der Verkleidung entfernen.

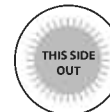

- Alle mit den Worten "THIS SIDE OUT" versehenen Platten müssen nach außen zeigen, um den vollen UV-Schutz zu gewährleisten. Entfernen Sie die Aufkleber, sobald die Platten montiert sind.



- Dieses Symbol zeigt an, dass sich die installierende Person sich im Inneren des Produktes befinden sollte.



- Dieses Symbol zeigt an, dass sich die installierende Person an der Außenseite des Produktes befinden sollte.

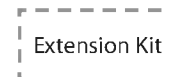

- Die mit Strichlinien markierten Schritte beziehen sich nur auf Erweiterungen.
- Einige der Schritte sind für den Zusammenbau eines einzelnen Produkts nicht relevant.
- Beim Zusammenbau eines einzelnen oder eines erweiterten Produkts können einige Teile überflüssig sein.

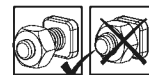

- Diese 2 Symbole unten zeigen an, ob das Anziehen der Schrauben erforderlich ist oder nicht.



- Das vorübergehende Anziehen einiger Schrauben kann erforderlich sein, um ein Herausrutschen des Profils zu verhindern.

- Ziehen Sie nach Abschluss der Montage alle Schrauben fest.



## WICHTIGE MONTAGESCHRITTE

**Wenn Sie bei der Montage auf dieses Informationssymbol stoßen, finden Sie im jeweiligen Montageschritt wichtige Zusatzhinweise.**

- Schritt 15:** Die matte Seite aller Produktplatten sollte nach immer außen verlegt werden! Verwenden Sie milde Seife, wenn nötig, um das Gleiten von Profilen und Paneelen zu erleichtern.
- Schritt 19:** Es wird empfohlen, die Schrauben **Nr. 8192** als Vorbereitung für die Montage von Regalen einzusetzen.  
Falls Sie ein **Regal-Kit** gekauft haben, montieren Sie maximal 2 Regalböden pro Pfosten.
- Schritt 24:** Beachten Sie die Richtung der Halterung, wie es auch in den Zeichnungen gezeigt wird, und stellen Sie sicher, dass die Halterung mit dem Rinnenprofil übereinstimmt.
- Schritt 26:** Achten Sie auf die Richtung der Halterung und stellen Sie sicher, dass die Schrauben im Inneren der Profile positioniert sind, so, wie es auch den Zeichnungen zu entnehmen ist.
- Schritt 27:** Es wird empfohlen, die Schrauben **Nr. 8192** als Vorbereitung für die Montage von Regalen einzusetzen.  
Falls Sie ein **Regal-Kit** gekauft haben, montieren Sie maximal 2 Regalböden pro Pfosten.
- Schritt 31:** Wenn Sie den **Yukon 11x21 / 3.3x6.4 Storage Shed**, gekauft haben, bauen Sie die Wände weiter und setzen Sie die Schrauben mit der Teilenummer **Nr. 8192** ein, um die Montage der Regale vorzubereiten, so, wie sie es in den letzten 4 Schritten gemacht haben.

- Schritt 32:** Es wird empfohlen, die Schrauben **Nr. 8192** als Vorbereitung für die Montage von Regalen einzusetzen.  
Falls Sie ein **Regal-Kit** gekauft haben, montieren Sie maximal 2 Regalböden pro Pfosten.
- Schritte 39+40:** Vor dem Einsetzen der Schrauben sicherstellen, dass die inneren Metallprofile nicht vorstehen und in den Aluminiumprofilen gut miteinander verbunden sind.
- Schritt 43:** Der Aufkleber muss auf eine saubere und trockene Oberfläche gelegt werden.
- Schritt 52:** Seien Sie langsam und vorsichtig beim Einschieben der Paneele.
- Schritt 55:** Vergewissern Sie sich, dass der Abstand zwischen den Aluminiumprofilen der Wand und der Rinne identisch ist, bevor Sie die Schrauben an der Innenseite anziehen.
- Schritt 72:** Vergewissern Sie sich, dass der gesamte Schuppen nivelliert ist, bevor Sie ihn am Grund Ihrer Wahl verankern.  
Verwenden Sie geeignete Schrauben und Dübel (nicht im Lieferumfang enthalten).

## PREPARACIÓN DEL SITIO Y CIMENTACIÓN

### A - PREPARE EL SITIO

Este producto debe construirse sobre una **base sólida y una superficie nivelada** para que funcione correctamente.

#### 1 - Limpie el sitio

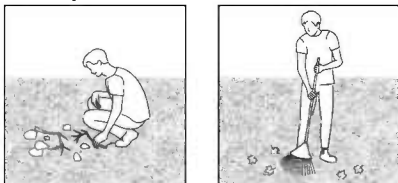

#### 2 - Nivele el terreno

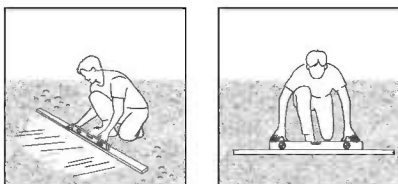

### IMPORTANTE

Recomendamos comprobar las restricciones o convenios para la construcción de este producto en su área. Además, aconsejamos comprobar si necesita presentar algún formulario o si se requiere algún permiso antes de construir el producto.

### B - ELIJA EL TIPO DE CIMENTACIÓN

Como base, recomendamos usar tres tipos de materiales:  
Hormigón | Madera prensada | Piso de madera | Adoquín de hormigón.

#### Base sólida

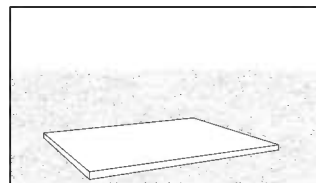

Preferido

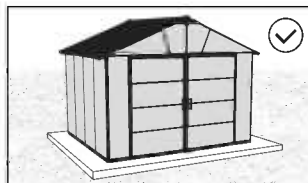

No es posible

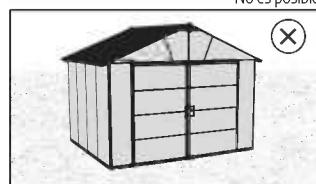

No es posible

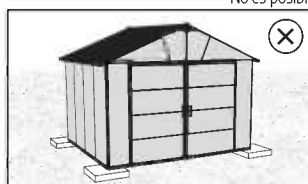

\* El tamaño del producto que se muestra tiene un propósito meramente ilustrativo y puede no reflejar el tamaño de su producto.

### C - ANCLAJE A LOS CIMIENTOS

#### Sobre una base sólida

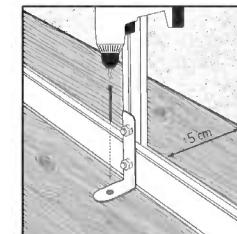
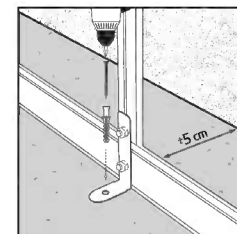

Asegure el producto a los cimientos de su elección, usando tornillos y tacos adecuados o anclajes de mampostería (no suministrados). Asegúrese de tener al menos 5 cm | 2" entre la base del producto y el perímetro de su cemento - **en todos los lados.**

## ACCESORIOS OPCIONALES



WPC Floor Kit



Floor Extension Kit

#### WPC Floor Kit:

Si ha comprado el **kit de piso** con el producto, los pasos relevantes están marcados con este icono. Si ha ensamblado el producto sin el kit de piso y desea agregar uno, consulte los pasos correspondientes en el ensamblaje y realice los ajustes necesarios.



#### Juego de estantería (Utility Shed Shelf Kit):

si ha comprado juegos de estante, se recomienda insertar tornillos # 411 dentro de las guías de los perfiles durante el montaje de las paredes.

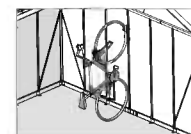

#### Suspensión vertical para bicicletas

##### (Vertical Bicycle Hanger):

se puede instalar una vez que el producto esté completamente ensamblado. Asegúrese de que la rueda inferior esté al nivel del piso.

## CONSEJOS DE SEGURIDAD

- Es de suma importancia montar todas las partes de acuerdo con las instrucciones. No se salte ningún paso.
- Recomendamos firmemente el uso de guantes de trabajo durante el montaje.
- Use siempre zapatos y gafas de seguridad al trabajar con aluminio extruido.
- Al usar una escalera plegable o herramientas eléctricas asegúrese de que sigue las instrucciones de seguridad de los fabricantes.
- No toque los cables eléctricos aéreos con los perfiles de aluminio.
- No intente montar el invernadero en días de viento o días con humedad.
- Disponga todas las bolsas plásticas en lugar seguro - guárdelas fuera del alcance de niños.
- Mantenga a los niños fuera del área de montaje.
- No se apoye ni empuje el producto durante la construcción.
- No coloque su producto en un área expuesta al viento excesivo.
- No intente montar este producto si usted está cansado, ha tomado drogas o alcohol o si usted es propenso a ataques de mareo.
- Artículos calientes recientemente usados tales como parrillas, sopletes etc. no deben ser almacenados en el producto.
- Asegúrese de que no hay tuberías o cables ocultos en el suelo antes de anclar a los cimientos.
- Este producto fue diseñado para ser utilizado principalmente como un Cobertizo de jardín.
- Para evitar que el agua se filtre por el suelo, el producto debe montarse sobre una superficie elevada del suelo.
- **Asegúrese de anclar el producto directamente a una base sólida para aumentar su estabilidad y resistencia al viento, especialmente en áreas con condiciones climáticas severas. Asegúrese de que no haya obstáculos entre la zona de montaje y la posición final del producto. El kit de anclaje de Palram - Canopia puede adquirirse por separado.**

## CUIDADOS & MANTENIMIENTO

- Cuando precise limpiar su producto, use una solución de detergente suave y aclare con agua limpia fría.
- NO use acetona, limpiadores abrasivos u otros detergentes especiales para limpiar los paneles transparentes.
- Limpie el producto una vez terminado el montaje.

## HERRAMIENTAS Y EQUIPOS

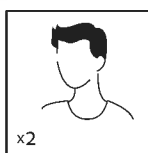

- Se necesitan dos personas

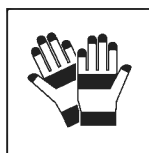

- Guantes de trabajo

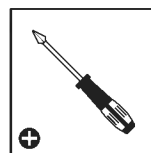

- Destornillador de cabeza Philips



- Silicona

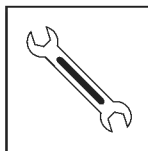

- Llave 10 mm | 13/32"

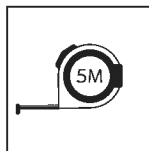

- Cinta métrica

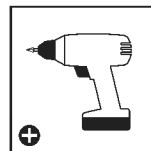

- Taladro inalámbrico: cabeza Philips

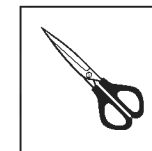

- Tijeras



- Jabón líquido



- Escalera

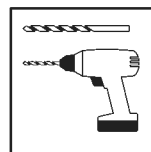

- Taladro inalámbrico: on broca o mecha

## ANTES DEL MONTAJE

1. Seleccionar un lugar:
  - Elija su sitio cuidadosamente antes del ensamblaje inicial.
  - El producto debe colocarse y fijarse en una superficie plana y nivelada.
  - Escoja una ubicación soleada y apartada de árboles que la cubran.
2. El producto debe fijarse directamente a una superficie sólida.
3. Este montaje consta de varias partes y sería óptimo que lo realizaran dos personas. El proceso de montaje llevará alrededor de medio día.
4. Extraiga todas las piezas de componentes de sus embalajes. Ordene las piezas y compruebe que están todas usando la lista de contenidos.
5. Las piezas deberían colocarse cerca y tenerlas a mano. Ponga las piezas pequeñas (p. ej. tornillos) en un bol para no perderlas.
6. Por favor, tenga en cuenta que este producto incluye perfiles con múltiples superficies. Como resultado, algunos de los agujeros de los perfiles no se utilizan durante el montaje.
7. Por favor, revise todas las instrucciones antes de empezar. Siga los pasos del montaje en el orden exacto.
8. Consulte las limitaciones, requisitos, permisos y a las autoridades locales para la construcción de este cobertizo de jardín.
9. Por favor asegúrese de que tiene suficiente espacio lateral para la inserción de los paneles del techo durante el proceso de montaje.

## ¡IMPORTANTE!

- Conecte firmemente el producto a una superficie nivelada inmediatamente después de terminar el montaje.
- Anclar este producto al suelo es esencial para su estabilidad y rigidez. Es necesario completar esta fase para que su garantía sea válida.
- Durante el montaje, ponga algo suave por debajo de las piezas, para evitar que se rayen o estropeen.
- Los dibujos en este manual están diseñados para cobertizos de 11x17 / 3.3x5.2 & 11x21 / 3.3x6.4.

## DURANTE EL MONTAJE

- Durante el montaje, se encontrará con diferentes iconos. Para obtener más información, consulte lo siguiente:



- Cuando encuentre el ícono de información, por favor lea con cuidado dicho paso con comentarios y asistencia adicionales.



- Puede utilizar spray lubricante de silicona para facilitar el deslizamiento de los paneles en los contornos. No ponga spray en los paneles.

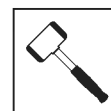

- Use un martillo de goma si hiciera falta.

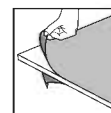

- Asegúrese de quitar la película plástica que cubre ambos lados del panel.

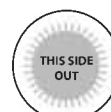

- Todos los paneles que tengan estampado LADO EXTERIOR (THIS SIDE OUT) deben mirar hacia fuera para ofrecer una protección UV completa. Quite la pegatina de plástico una vez los paneles se enganchen en su sitio.



- Este ícono indica que el instalador debe estar dentro del producto.



- Este ícono indica que el instalador debe estar fuera del producto.

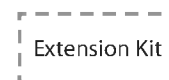

- Los pasos marcados con líneas discontinuas se refieren únicamente a las extensiones.

- Algunos de los pasos son innecesarios para el montaje de un solo producto.

- Durante el montaje de un producto individual o de una extensión, pueden sobrar algunas piezas.

- Los siguientes 2 íconos le indicarán si el ajuste de los tornillos es necesario o no.

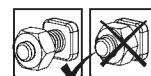

- en algún paso puede ser necesario apretar de forma temporal algunos tornillos para evitar que se caiga un perfil.



- Apriete todos los tornillos una vez esté completado el montaje



## PASOS DE MONTAJE IMPORTANTES

**Al encontrar este icono de información durante el montaje, consulte el paso de montaje correspondiente para obtener importantes comentarios adicionales.**

- Paso 15:** ¡El lado mate de todos los paneles del producto debe estar mirando hacia afuera!
- Paso 19:** Es recomendado insertar los tornillos **#8192** como preparación para las repisas de montar.  
Si ha comprado el **Juego de estantería**, un máximo de 2 por poste.
- Paso 24:** Observe la dirección del soporte como se muestra en los dibujos, asegúrese de que el soporte esté alineado con la canaleta del perfil.
- Paso 26:** Observe la dirección del soporte y asegúrese de que los tornillos estén colocados dentro de las canaletas del perfil, como se muestra en los dibujos.
- Paso 27:** Es recomendado insertar los tornillos **#8192** como preparación para las repisas de montar.  
Si ha comprado el **Juego de estantería**, un máximo de 2 por poste.
- Paso 31:** Si compró el cobertizo de almacenamiento **Yukon 11x21 / 3.3x6.4 Storage Shed**, continúe construyendo las paredes, agregando el soporte adicional e insertando los tornillos **#8192** como preparación para el montaje de los estantes, tal como lo hizo en los últimos 4 pasos.

- Paso 32:** Es recomendado insertar los tornillos **#8192** como preparación para las repisas de montar.  
Si ha comprado el **Juego de estantería**, un máximo de 2 por poste.
- Pasos 39+40:** Antes de insertar los tornillos, asegúrese de que los perfiles metálicos internos no sobresalgan y estén bien conectados entre sí, dentro de los perfiles de aluminio.
- Paso 43:** La etiqueta debe ser colocada en una superficie limpia y seca.
- Paso 52:** Al deslizar los paneles hacia adentro, desacelere y tenga cuidado.
- Paso 55:** Asegúrese de que la distancia entre los perfiles de aluminio de la pared y la canaleta sea idéntica antes de apretar los tornillos en el interior.
- Paso 72:** Asegúrese de que el cobertizo esté nivelado antes de anclarlo a la superficie que elija.  
Use tornillos y tacos adecuados (no incluidos).

## הכנת האתר והיסודות

### א. הכן את האתר

את המוצר יש להקים על **קרקע יציבה ומפולסת** בכדי שהוא יתפקד כראוי.

#### 1 - פנה את האתר

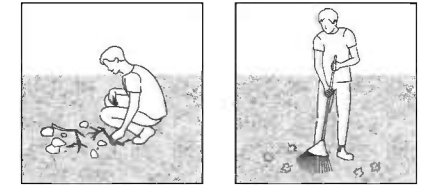

#### 2 - פלס את הקרקע

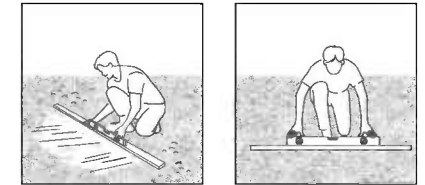

### חשוב

אנו ממליצים לבדוק האם יש מגבלות חוקיות להקמת מבנה זה באזורכם. בנוסף, אנחנו מציעים שתבדקו האם אתם חייבים להגיש טפסים כלשהם, האם יש צורך בהיתר לפני שאתם מתחילים בבנייתו של המוצר.

### ב. בחר את סוג היסודות שלך

בתור בסיס אנו ממליצים לעשות שימוש בשלושה סוגי חמרים: בטון | עץ שעבר טיפול הקשייה/דק עץ | בלוקים לריצוף

#### בסיס מוצק

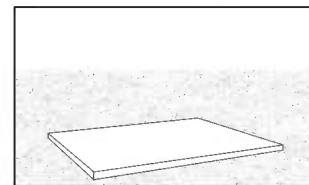

#### בלתי אפשרי

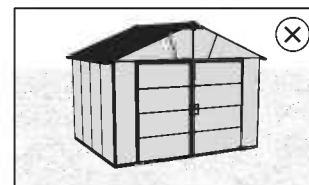

#### מועדף

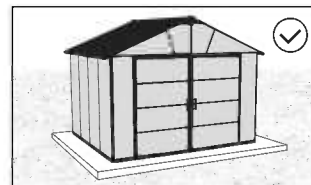

#### בלתי אפשרי

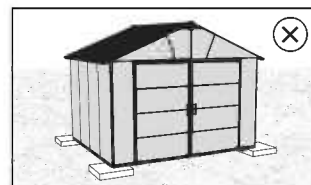

\* גודל המוצר המוצג הינו להדגמה בלבד ולא מייצג את גודל המוצר שלכם.

### ג. עגן את הבסיס

#### על בסיס מוצק

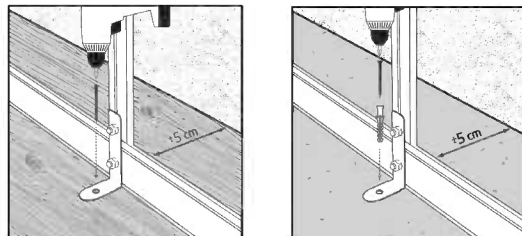

חבר את המוצר לבסיס (יסוד) שבחרת והשתמש בברגים מתאימים וסגרים, או עוגני בנאות (לא סופקו).

וודאו שיש לכם לכול הפחות 5 סמ' בין מסגרת המוצר וקצות הבסיס (היסוד) - **בכל הצדדים**.

## אביזרים אופציונליים

### ערכת רצפת WPC:

אם רכשת את ערכת הרצפה עם המוצר, השלבים הרלוונטיים מסומנים בסמלים אלו. אם הרכבת את המוצר ללא ערכת הרצפה ואתה מעוניין להוסיף כזו, אנא פנה לשלבים הרלוונטיים (המסומנים בסמלים אלו) בהרכבה ובצע את ההתאמות הנדרשות.



### ערכת מדף למחסן:

אם רכשת ערכות מדפים, מומלץ להכניס את ברגי #411 לתוך מסלולי המוצר בעת ההרכבה של קיר המחסן.

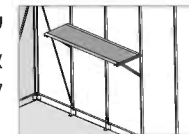

### מתלה אופניים אנכי:

ניתן להתקנה לאחר הרכבתו המלאה של המוצר. יש לוודא שהגלגל התחתון הוא בגובה הרצפה.

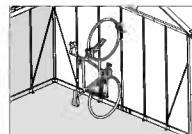



## הצעת בטיחות



- יש להקפיד ולהרכיב את כל החלקים בהתאם להוראות. אין לדלג על שום שלב.
- אנו ממליצים מאד להשתמש בכפפות עבודה במהלך ההרכבה.
- בעת השימוש באלומיניום משוחל יש לנעול תמיד נעלי עבודה ומשקפי מגן.
- בשימוש בסולם או במכשירים חשמליים, יש למלא אחר הוראות הבטיחות של היצרן.
- יש להמנע מנגע של פרופילי האלומיניום עם כבלי חשמל עיליים.
- אין לנסות להרכיב את המוצר בזמן רוחות או תנאי רטיבות.
- בכדי למנוע סכנת חנק, יש להרחיק את חומרי האריזה מהישג ידם של ילדים.
- יש להרחיק ילדים מאזור ההרכבה.
- אין להישען על או לדחוף את המוצר בעת ההרכבה.
- אין למקם את המוצר במקום החשוף לרוחות חזקות.
- אין לנסות להרכיב את המוצר במצב עייפות, שימוש בסמים, תרופות או אלכוהול, או אם יש נטייה לסחרחורת.
- אין לאחסן במוצר פריטים חמים כגון גריל שנעשה בו שימוש לאחרונה, מבערים וכד'.
- יש לוודא כי אין צינורות או כבלים נסתרים בקרקע או הקיר לפני העיגון אל המשטח הקיים.
- מוצר זה תוכנן לשמש בעיקר כמחסן.

- כדי למנוע מים לחלחל דרך הרצפה, יש להתקין את המוצר על גבי משטח מוגבה מהקרקע.
- עליך לעגן את המוצר ישירות אל בסיס מוצק בכדי להגדיל את יציבות המוצר ועמידות לרוחות באזורים עם תנאי מזג אוויר קשים. יש לוודא כי אין מכשולים בין אזור ההרכבה למיקום הסופי של המוצר. את ערכת העיגון של Palram - Canopia ניתן לרכוש בנפרד.**

## טיפול ותחזוקה

- כדי לנקות את המוצר יש להשתמש בסבון עדין ולרחוץ במים קרים נקיים.
- אין להשתמש באצטון, חומרי ניקוי שוחקים וסבונים מיוחדים.
- יש לנקות את המוצר בסיום ההתקנה.

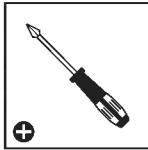
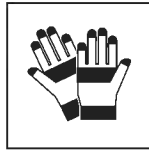
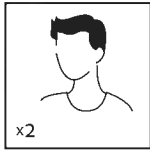
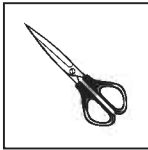
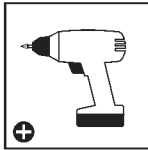
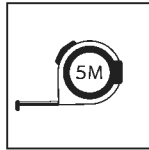
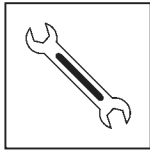
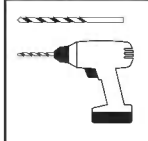
## כלים וציוד

<input type="checkbox"/> סיליקון		<input type="checkbox"/> מברג פיליפס		<input type="checkbox"/> כפפות עבודה		<input type="checkbox"/> נחוצים שני אנשים	
<input type="checkbox"/> מספריים		<input type="checkbox"/> מקדחה ניידת עם ראש פיליפס		<input type="checkbox"/> סרט מדידה		<input type="checkbox"/> מפתח ברגים 10 mm   13/32"	
		<input type="checkbox"/> מקדחה ניידת עם מקדחים		<input type="checkbox"/> סולם		<input type="checkbox"/> סבון נוזלי	

## במהלך ההרכבה

• במהלך ההרכבה, תפגוש אייקונים שונים למוצרים שונים, הבט מטה לעוד אינפורמציה:

- כאשר מופיע סימן זה, נא לעיין בשלב ההרכבה המצוין כדי לקרוא הערות ומידע נוסף.
- ניתן להשתמש בספריי סיליקון בכדי לסייע לך להשחיל את הלוחות אל תוך הפרופילים. אין להתיז ספריי סיליקון על הלוח.
- במידת הצורך, השתמש בפטיש גומי.
- הסר את ציפוי הפלסטיק משני צדדי הפנל לפני הרכבתו.
- נא לשים לב שהלוחות מורכבים כאשר החלק המוגן נגד UV כלפי חוץ (מצוין עליו "THIS SIDE OUT") ולקלף בסיום את המדבקה כאשר הלוחות מונחים ונעולים במקומם.
- סמל זה מציינ שעל המרכיב להיות בתוך המוצר.
- סמל זה מציינ שעל המרכיב להיות מחוץ למוצר.
- השלבים המסומנים בקו מקוקו מתייחסים אל ההארכה בלבד.
  - ניתן להתקין עד שלושה מוצרים מחוברים יחד.
  - חלק מהשלבים אינם רלוונטיים להרכבת גגון אחד.
  - בעת הרכבת מוצר בודד או מוצר הארכה, חלקים מסוימים עשויים להיות עודפים.
- 2 סמלים אלה מציינים האם נחוץ הידוק או לא. בחלק מהשלבים, הידוק זמני של הברגים עשוי להיות נחוץ בכדי למנוע את נפילתו של פרופיל.
- הדק את הברגים היטב בסיום ההרכבה.

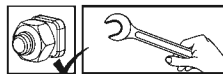
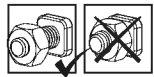
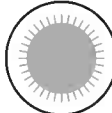
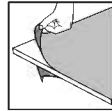

## לפני ההרכבה

1. בחירת מיקום ההרכבה:
  - בחר בתשומת לב את מיקום ההרכבה לפני תחילת ההרכבה.
  - יש לבחור אזור שטוף-שמש, רחוק מהעצים.
  - על הקרקע להיות שטוחה ומפולסת לחלוטין ובעלת בסיס מוצק כגון: בטון, אספלט, דק מעץ וכו'.
2. יש למקם את המוצר ולקבע אותו על משטח שטוח וישירות לבסיס מוצק.
3. זהו מוצר מרובה חלקים, לשם הרכבתו יש צורך בשני אנשים. תכנן לפחות חצי יום לביצוע ההרכבה.
4. יש למיין את החלקים ולבדוק כמויות אל מול רשימת התכולה.
5. יש להניח את חלקי ההרכבה בקרבה למקום ההרכבה. שמור את החלקים הקטנים בקערה על מנת שלא יאבדו.
6. יתכן שבמוצר זה ישנם פרופילים שיש להם שימושים שונים, לכן יתכנו חורים שאין בהם צורך.
7. אנא עיין בהוראות המלאות לפני שתתחיל. בצע את שלבי ההרכבה בסדר המדויק.
8. אנא בדוק מול הרשויות אם יש צורך בהיתרים כלשהם טרם הרכבת המוצר.
9. אנא וודא שקיים מספיק מרווח בצדדים להכנסת לוחות הגג במהלך ההרכבה.

## חשוב!

- עיגון המוצר לקרקע חיוני ליציבות ועמידותו. תוקף האחריות תלוי בהשלמת שלב זה.
- מיד לאחר השלמת ההרכבה, יש לעגן מיד את המוצר היטב כשהקרקע במצב מפולס. חובה להשלים שלב זה בכדי שהאחריות תהיה בתוקף.
- בעת ההרכבה, השתמש במשטח רך מתחת לחלקים בכדי למנוע שריטות ונזק.
- האיורים במדריך זה מתאימים למוצרים: 11x17 / 3.3x5.2 או 11x21 / 3.3x6.4.



## שלבים חשובים בהרכבה

**כאשר אתם רואים את הסמל הזה במהלך ההרכבה, אנא פנו אל שלב ההרכבה לקבלת הערות חשובות נוספות.**

**שלב 15:**

הצד המט של כל לוחות המוצר צריך לפנות כלפי חוץ! השתמש בסבון עדין אם הדבר נדרש להשחלה קלה של הפרופילים והלוחות.

**שלב 19:**

מומלץ להכניס את הברגים #8192 כהכנה להתקנת מדפים. אם רכשת **ערכת מדף למחסן**, יש להרכיב לכל היותר 2 מדפים על כל עמוד.

**שלב 24:**

אנא שימו לב לכיוון פרופיל החיזוק כפי שמופיע באיור, אנא וודאו כי הפרופיל מיושר עם פרופיל המרזב.

**שלב 26:**

אנא שימו לב לכך שכיוון פרופיל החיזוק ומיקום הברגים בתעלות הינם כפי שמופיע באיור.

**שלב 27:**

מומלץ להכניס את הברגים #8192 כהכנה להתקנת מדפים. אם רכשת **ערכת מדף למחסן**, יש להרכיב לכל היותר 2 מדפים על כל עמוד.

**שלב 31:**

במידה ורכשת מחסן יוקון Yukon 11x21 / 3.3x6.4, אנא המשיכו את בניית הקירות והוספת פרופיל החיזוק וההכנה למדפים, כפי שביצעתם ב 4 השלבים הקודמים.

**שלב 32:**

מומלץ להכניס את הברגים #8192 כהכנה להתקנת מדפים. אם רכשת **ערכת מדף למחסן**, יש להרכיב לכל היותר 2 מדפים על כל עמוד.

**שלבים**

**:39+40**

לפני הכנסת הברגים, וודא שפרופילי המתכת הפנימיים אינם בולטים כלפי חוץ ושהם מחוברים היטב זה לזה בתוך פרופילי האלומיניום.

**שלב 43:**

יש להדביק את המדבקה על משטח נקי ויבש.

**שלב 52:**

עבוד לאט ובזהירות בעת השחלת הלוחות פנימה.

**שלב 55:**

וודא שהמרחק בין פרופילי האלומיניום של הקירות והמרזב זהה לפני הידוק הברגים מבפנים.

**שלב 72:**

וודא שהמחסן מיושר לפני עיגונו למשטח שבחרת. השתמש בברגים וביתדות מתאימים (לא כלולים בערכה).

ט.ל.ח.

## FORBEREDELSE AV OMRÅDE OG FUNDAMENT

### A - FORBERED OMRÅDET

Produktet må være på en **solid og flat** overflate for å fungere korrekt.

#### 1 - Rydd området

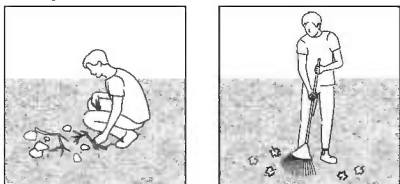

#### 2 - Flat ut bakken

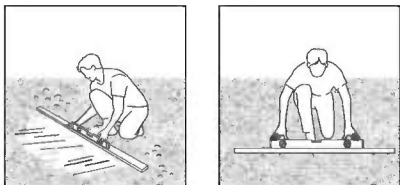

### VIKTIG

Vi anbefaler at du sjekker restriksjoner og begrensninger for konstruksjon av dette produktet i ditt område. I tillegg anbefaler vi at du sjekker om du må fylle ut skjemaer eller søke om tillatelser før du bygger produktet.

### B - VELG FUNDAMENTTYPE

Som base anbefaler vi tre typer materiell:  
Betong | Trykkbehandlet tre/tredekke | Belegningsstein

#### Solid base

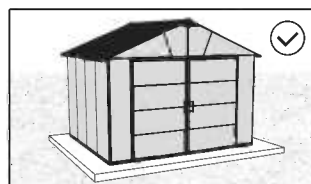
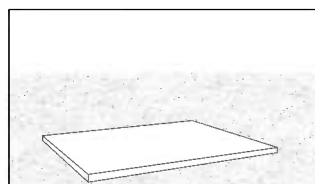

Foretrukket

Ikke mulig

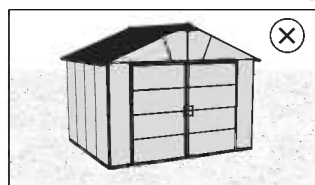

Ikke mulig

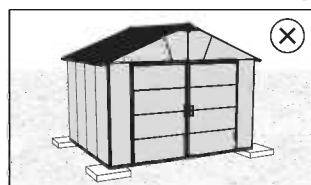

\* produktets størrelse er bare for illustrasjon, og viser ikke korrekt størrelse på ditt produkt.

### C - FEST TIL FUNDAMENT

#### På en solid base

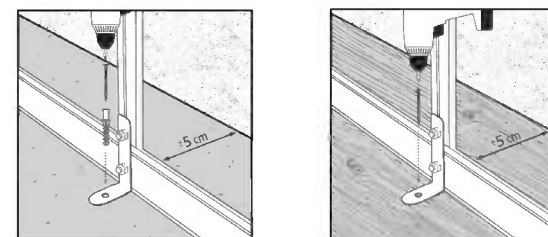

Sikrer du produktet til fundamentet du har valgt med passende skruer, pluggar eller murfester (ikke inkludert).

Forsikre deg om at du har minst 5 cm | 2 " mellom bunnen av produktet og kantene på fundamentet ditt - **på alle sider.**

## VALGFRITT TILBEHØR



WPC Floor Kit



Floor Extension Kit

#### WPC Floor Kit:

Hvis du kjøpte **gulvsettet** med produktet, er de aktuelle trinnene merket med dette ikonet. Hvis du har montert produktet uten gulvsettet og ønsker å legge det til, se de aktuelle trinnene i håndboken og gjør nødvendige justeringer.

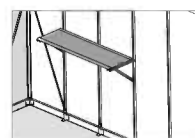

#### Hyllesett:

Hvis du har kjøpt hyllesett, anbefales det å feste skruene (#411) i profilsprene under veggmonteringen.

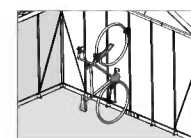

#### Vertikalt sykkelstativ:

Kan installeres når produktet er ferdig montert. Pass på at det nederste hjulet er på gulv nivå.

## SIKKERHETSÅD

- Utfør monteringen i henhold til disse anvisningene.
- Bruk vernehansker.
- Bruk sko og vernebriller ved arbeid med aluminiumsprofiler.
- Følg produsentens sikkerhetsanvisninger for verktøy og annet utstyr.
- Pass på at aluminiumsprofilene ikke kommer i kontakt med strømkabler eller ledninger.
- Ikke forsøk å montere produktet når det blåser eller regner.
- Emballasjen skal avhendes i henhold til gjeldende regler. Oppbevar plastposer utilgjengelig for barn – kvelningsfare.
- Hold barn på trygg avstand fra arbeidsområdet.
- Ikke trykk eller vipp på produktet under monteringen.
- Ikke plasser produktet slik at det utsettes for sterk vind.
- Forsøk aldri å montere produktet hvis du er trøtt eller påvirket av narkotika, legemidler eller alkohol.
- Varmt gjenstander som for eksempel brukte griller, blowtorches etc. må ikke lagres inne i produktet.
- Før du forankrer produktet i fundamentet, sørg for at det ikke er skjulte rør eller kabler der.
- Dette produktet ble laget for å brukes i hovedsak som Hageskur.
- For å forhindre at vann siver gjennom gulvet, må produktet monteres på en hevet overflate fra bakken.
- **For å øke stabiliteten og vindmotstanden til produktet, må du forankre det direkte på et solid fundament, spesielt i de områdene der værforholdene er alvorlige. Forsikre deg om at det ikke er noen hindringer mellom forankringsområdet og produktets endelige posisjon. Palram - Canopia forankringssett kan kjøpes separat.**

## VEDLIKEHOLD OG RENGJØRING

- Rengjør produktet med mildt rengjøringsmiddel og skyll med kaldt vann.
- Bruk ikke aceton, slipende rengjøringsmidler eller andre kjemikalier på degjennomsiktige delene.
- Rengjør produktet når monteringen er ferdig.

## VERKTØY OG UTSTYR

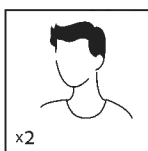

- To personer nødvendig

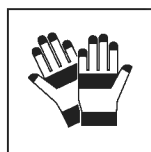

- Arbetshanskar

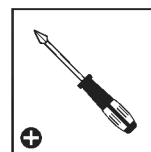

- Phillips skrutrekker

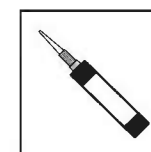

- Silikon

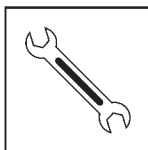

- Skiftenøkkel 10 mm | 13/32"

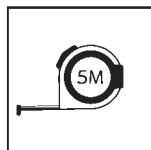

- Målebånd

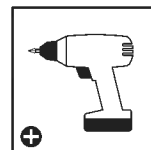

- Trådløs drill - Phillips-hode

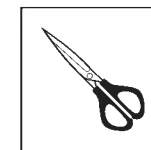

- Saks



- Flytende såpe



- Stige

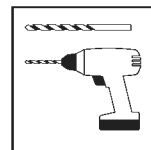

- Trådløs drill med bor

## FØR MONTERING

1. Velg et sted:
  - Velg grunnlaget med omhu før du monterer.
  - Velg en solrik beliggenhet uten overhengende trær.
  - Produkt må plasseres og festes på et flatt underlag.
2. Produktet må festes direkte på en solid overflate.
3. Denne flerdelte monteringen oppnås best av to personer. Beregn minst en halv dag for monteringsprosessen.
4. Sorter delene og sjekk dem opp mot delelisten.
5. Delene bør legges ut slik at du lett kan nå dem. Hold alle små deler (skruer osv) i en bolle slik at de ikke forsvinner.
6. Legg merke til at flersidige profiler er brukt i dette produktet. Dette betyr at enkelte av hullene profilene ikke blir brukt under monteringen.
7. Les gjennom hele instruksjonene før du starter. Utfør monteringsstrinnene i nøyaktig rekkefølge.
8. Kontakt lokale myndigheter for å se om du trenger byggetillatelse for å sette opp dette produkt.
9. Forsikre deg om at du har tilstrekkelig sideplass for å sette inn takpanelene under monteringsprosessen.

## VIKTIG!

- Etter fullført montering må produktet forankres umiddelbart på et flatt underlag.
- Forankring av dette produktet til gulvet er avgjørende for dets stabilitet og styrke. Dette trinnet er også nødvendig på grunn av garantiens gyldighet.
- Det anbefales å bruke kartong eller et annet mykt materiale under det senkede hjørnet for å unngå riper og malingskader.
- Tegningene i denne håndboken er laget for produktets 11x17 / 3.3x5.2 & 11x21 / 3.3x6.4.

## UNDER FORSAMLINGEN

- Under montering vil du møte på forskjellige ikoner for forskjellige produkter. Vennligst se nedenfor for mer informasjon:



- Under monteringen vil du møte på informasjonsikonet, hvor det henvises det til det relevante monteringstrinnet for flere kommentarer og hjelp.



- Du kan bruke silikonspray for å hjelpe med at panelene sklir inn i profilene. Ikke spray paneler.



- Bruk gummihammer hvis nødvendig.

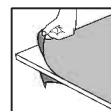

- Må du sørge for å fjerne dekkende plastfilm fra begge sider av panelet.

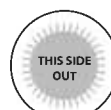

- Alle panelene med de stemplede ordene "THIS SIDE OUT" må vendes ut for å danne fullstendig UV-beskyttelse. Fjern plastfilmen når panelene er festet på plass.



- Dette symbolet indikerer at montøren skal befinne seg på utsiden.



- Dette symbolet indikerer at montøren skal befinne seg på innsiden.

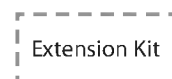

- Trinn markert med stiplede ytterlinjer viser kun til utvidelser.
- Noen av trinnene er uten betydning for montering av et enkelt produkt.
- Når du setter sammen et enkelt eller et utvidet produkt, kan noen deler være til overs.

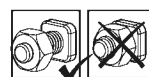

- Disse to ikonene indikerer om det er nødvendig å stramme skruene
- Tilidertid kan være nødvendig å midlertidig stramme enkelte skruer for noen av trinnene for å hindre av profilen faller.



- Stram alle skruer når du er ferdig med monteringen.



## VIKTIGE MONTERINGSTRINN

Når du ser dette ikonet under montering, vennligst se relevant monteringstrinn for viktige tilleggskommentarer.

- Trinn 15:** Den matte siden skal vende ut på alle paneler!  
Bruk mild såpe hvis nødvendig for å gjøre skyvingen av profiler og paneler lettere.
- Trinn 19:** Det anbefales å sette inn skruene **#8192** som forberedelse til montering av hyllene.  
Hvis du har kjøpt et **hyllesett**, bør du montere maks 2 hyller per stang.
- Trinn 24:** Legg merke til brakettens retning som vist på tegningene, sørg for at braketten er på linje med takrennen.
- Trinn 26:** Legg merke til brakettens retning, og sørg for at skruene er plassert som vist på tegningene i profilens kanaler.
- Trinn 27:** Det anbefales å sette inn skruene **#8192** som forberedelse til montering av hyllene.  
Hvis du har kjøpt et **hyllesett**, bør du montere maks 2 hyller per stang.

- Trinn 31:** Hvis du har kjøpt **Yukon 11x21 / 3.3x6.4 lagringsbod**, kan du fortsette å bygge veggene, legge til den ekstra braketten og sette inn skruer **#8192** som forberedelse til montering av hyller, som gjort i de 4 siste stegene.
- Trinn 32:** Det anbefales å sette inn skruene **#8192** som forberedelse til montering av hyllene.  
Hvis du har kjøpt et **hyllesett**, bør du montere maks 2 hyller per stang.
- Trinn 39+40:** Før du setter inn skruene, må du sørge for at de indre metallprofilene ikke stikker ut og er godt festet til hverandre inne i aluminiumsprofilene.
- Trinn 43:** Klistremerket må plasseres på en ren og tørr overflate.
- Trinn 52:** Vær forsiktig når du skyver inn panelene.
- Trinn 55:** Pass på at avstanden mellom veggens aluminiumsprofiler og takrennen er like lang før du trekker til skruene på innsiden.
- Trinn 72:** Sørg for at boden står flatt før du forankrer den til underlaget. Bruk egnede skruer og plugg (ikke inkludert).

## VOORBEREIDING VAN TERREIN & FUNDERING

### A - TERREIN VOORBEREIDEN

Het product moet op een **stevige en egale oppervlakte** gebouwd worden om goed te kunnen werken.

#### 1 - Maak het terrein vrij

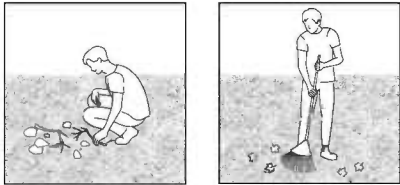

#### 2 - Egaliseer de grond

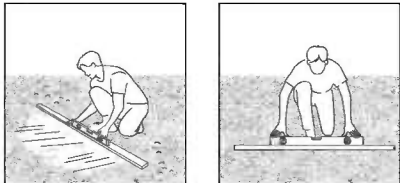

### BELANGRIJK

Wij raden u aan te controleren of er beperkingen of convenanten van toepassing zijn voor het bouwen van dit product in uw omgeving. Daarnaast adviseren wij om te controleren of u formulieren moet indienen of dat er een vergunning nodig is voordat u het product opbouwt.

### B - KIES UW TYPE FUNDERING

Als basis adviseren wij drie materiaalsoorten te gebruiken:  
Beton | Onder druk behandeld hout/houten dek | Bestratingsblokken

#### Massieve basis

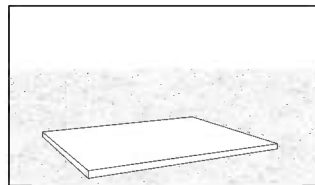

Voorkeur

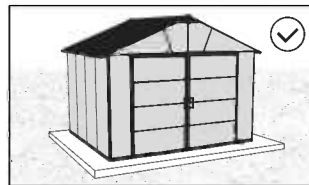

Niet mogelijk

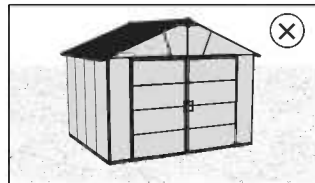

Niet mogelijk

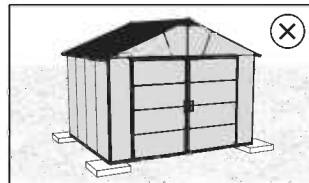

\* De grootte van de getoonde Product dient enkel ter illustratie en weerspiegelt mogelijk niet de grootte van uw eigen Product.

### C - VERANKERING AAN FUNDERING

#### Op een stevige basis

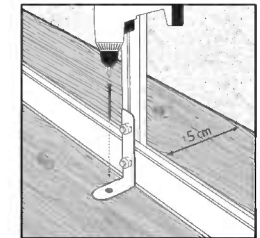
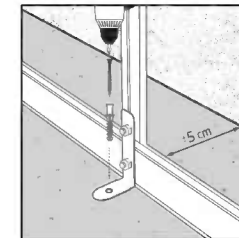

Zet het product op een stevige basis vast op de fundering van uw keuze, met geschikte schroeven & pluggen of metselwerkankers (niet meegeleverd).

Zorg ervoor dat u minstens 5 cm hebt tussen de basis van het product en de randen van uw fundering - **langs alle kanten.**

## OPTIONELE ACCESSOIRES



WPC Floor Kit



Floor Extension Kit

#### WPC-vloerkit:

Als u de vloerkit bij het product hebt gekocht, zijn de relevante stappen gemarkeerd met deze pictogrammen. Als u het product hebt geassembleerd zonder de vloerkit en er een wilt toevoegen, raadpleegt u de relevante stappen (gemarkeerd met deze pictogrammen) in de assembly en voer de nodige aanpassingen uit.



#### Schappensets:

Als u schappensets hebt gekocht, wordt het aanbevolen om schroeven # 411 in de profielen te plaatsen tijdens de montage van de wanden.

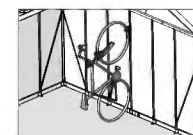

#### Verticale fietshanger:

Kan worden geïnstalleerd als het product volledig is gemonteerd. Zorg ervoor dat het onderste wiel op vloerniveau staat.



## VEILIGHEIDSADVIES

- Het is uiterst belangrijk alle onderdelen volgens de richtlijnen te monteren. Sla geen enkele stap over.
- Het is ten zeerste aanbevolen om werkhandschoenen te dragen tijdens de montage.
- Draag altijd schoenen en een veiligheidsbril als u met geëxtrudeerd aluminium werkt.
- Als u een ladder of elektrisch gereedschap gebruikt, wees zeker dat u het veiligheidsadvies van de fabrikant volgt.
- Raak de bovengrondse electriciteitskabels niet aan met de aluminium profielen.
- Probeer de product niet te monteren in winderige of natte omstandigheden.
- Verwijder alle plastic veiligheidszakken en houd ze buiten bereik van kleine kinderen.
- Houd kinderen uit het montagegebied.
- Leun niet of druk niet aan de product gedurende de montage.
- Plaats uw product niet in een gebied met overmatige wind.
- Probeer de product niet te monteren indien u moe bent, drugs of alcohol gebruikt heeft of als u lijdt aan aanvallen van duizeligheid.
- Hete voorwerpen zoals recent gebruikte grills, branders, enz. mogen niet in de product opgeslagen worden.
- Zorg ervoor dat er geen verborgen leidingen of kabels zijn voordat u het product aan de fundering verankert.
- Dit product werd ontworpen om hoofdzakelijk te worden gebruikt als Tuinhuisjes.
- Om te voorkomen dat er water door de vloer sijpelt, moet het product vanaf de grond op een verhoogd oppervlak worden gemonteerd.
- **Om de stabiliteit en windweerstand van het product te vergroten, moet u het direct op een stevige ondergrond verankeren, vooral in die gebieden waar de weersomstandigheden zwaar zijn. Zorg ervoor dat er geen obstakels zijn tussen het montagegebied en de uiteindelijke positie van het product. De Palram - Canopia Anchoring kit is apart verkrijgbaar.**

## SCHOONMAAK INSTRUCTIES

- Om de Artikel schoon te maken, gebruik slecht milde reinigers en spoel dit af met schoon en koud water.
- Gebruik geen aceton, schurende detergenten of andere speciale middelen voor het reinigen van de panelen.
- Maak het product schoon na assemblage.

## GEREEDSCHAP & UITRUSTING

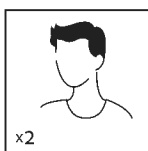

Twee Mensen Nodig

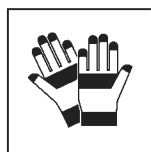

Werkhandschoenen

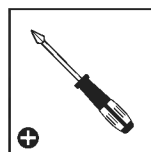

Kruiskopschroevendraaier



Siliconen

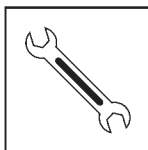

Moersleutel  
10 mm | 13/32"

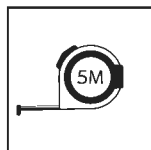

Meetlint

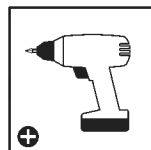

Draadloze Boormachine –  
Kruiskopschroeven

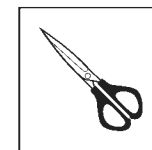

Schaar



Vloeibare Zeep



Ladder

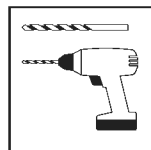

Draadloze Boormachine  
Met Boorbeitel

## VÓÓR DE VERGADERING

- Selecteer een site:
  - Kies deze locatie zorgvuldig voordat u begint met de montage.
  - Kies een zonnige positie weg van overhangende bomen.
  - Het grondoppervlak moet perfect vlak en waterpas zijn en een stevige ondergrond hebben.
- Het product moet direct op een stevige ondergrond worden bevestigd.
- Dit is een multi-part montage en kan het beste worden gedaan door twee personen. Houd tenminste rekening met een halve dag voor het montageproces.
- Sorteer de onderdelen en controleer dit met de materiaallijst.
- Onderdelen moeten dicht bij de hand liggen. Bewaar alle kleine onderdelen (schroeven, enz.) in een kom zodat je ze niet verliest.
- Let wel dat er meerszijdige profielen worden gebruikt in product. Als gevolg kunnen er sommige gaten in de profielen zitten die niet worden gebruikt gedurende de montage.
- Lees de gehele instructies voordat u begint. Voer de montagestappen uit in de exacte volgorde.
- Raadpleeg uw plaatselijke autoriteiten of er bepaalde vergunningen vereist zijn voordat u het product gaat bouwen.
- Zorg ervoor dat u tijdens de montage voldoende zijruimte heeft om de dakpanelen te plaatsen.

## BELANGRIJK!

- Na voltooiing van de montage moet het product direct op een vlakke ondergrond worden verankerd.
- Het verankeren van dit product aan de vloer is essentieel voor zijn stabiliteit en sterkte. Deze stap is ook nodig vanwege de geldigheid van de garantie.
- Gebruik een zachte ondergrond voor de onderdelen om krassen en beschadigingen te voorkomen.
- De tekeningen in deze handleiding zijn ontworpen voor 11x17 / 3.3x5.2 & 11x21 / 3.3x6.4 -product.

## TIJDENS DE ASSEMBLAGE

- Tijdens de montage zult u verschillende iconen voor verschillende producten aantreffen. Kijk hieronder voor meer informatie:



- Wanneer u het informatie-icoon ziet, ga dan naar de relevante montage stap voor aanvullende opmerkingen en assistentie.



- U kunt siliconenspray gebruiken om de panelen gemakkelijker in de profielen te schuiven. Spray niet de panelen.



- Gebruik een rubberen hamer indien nodig.

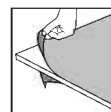

- Moet u ervoor zorgen dat u de afdekfolie aan beide zijden van het paneel verwijdert

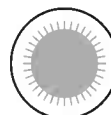

- Alle panelen met de gestempelde woorden "THIS SIDE OUT" moeten naar buiten wijzen om volledige UV-bescherming te creëren. Verwijder de plastic sticker nadat de panelen op hun plaats vast zijn gezet.



- Dit icoontje geeft aan dat de installateur binnen het product moet zijn.



- Dit icoontje geeft aan dat de installateur buiten het product moet zijn.



- Stappen gemarkeerd met gestreepte omtrek verwijzen enkel naar uitbreidingen.

- Sommige van de stappen zijn irrelevant voor de montage van een enkel product.

- Bij het monteren van een enkel of een uitgebreid product, kunnen sommige onderdelen op overschot zijn.

- Deze 2 icoontjes geven aan of het vastdraaien van schroeven is vereist.

- Tijdelijk vastzetten van een aantal schroeven is mogelijk nodig om te voorkomen dat een profiel naar buiten schuift.

- Maak het product schoon na assemblage.

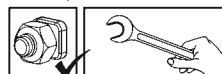
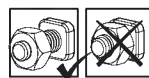



## IMPORTANT ASSEMBLY STEPS

**When encountering this information icon during assembly, please refer to the relevant assembly step for important additional comments.**

- Stap 15:** Matte zijde van alle panelen van het product moet naar buiten gericht zijn!  
Gebruik indien nodig milde zeep om het glijden van profielen en panelen te vergemakkelijken.
- Stap 19:** Het wordt aanbevolen om schroeven **#8192** aan te brengen als voorbereiding voor het monteren van planken.  
Als u een **Schappensets** hebt aangeschaft, kunt u maximaal 2 planken per paal plaatsen.
- Stap 24:** Let op de richting van de beugel zoals aangegeven in de tekeningen, zorg ervoor dat de beugel in lijn ligt met het profiel van de goot.
- Stap 26:** Let op de richting van de beugel en zorg ervoor dat de schroeven in de goten van het profiel zitten, zoals aangegeven in de tekeningen.
- Stap 27:** Het wordt aanbevolen om schroeven **#8192** aan te brengen als voorbereiding voor het monteren van planken.  
Als u een **Schappensets** hebt aangeschaft, kunt u maximaal 2 planken per paal plaatsen.
- Stap 31:** Als u de **Yukon 11x21 / 3.3x6.4** Opslagschuur heeft gekocht, ga dan verder met het bouwen van de wanden, het toevoegen van de extra beugel en het plaatsen van de schroeven **#8192** als voorbereiding voor het monteren van de planken, zoals in de laatste 4 stappen.











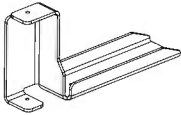

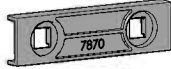

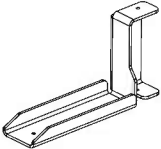
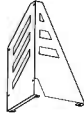
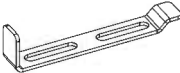

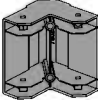

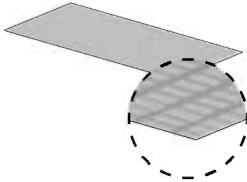
- Stap 32:** Het wordt aanbevolen om schroeven **#8192** aan te brengen als voorbereiding voor het monteren van planken.  
Als u een **Schappensets** hebt aangeschaft, kunt u maximaal 2 planken per paal plaatsen.
- Stappen 39+40:** Voordat u de schroeven installeert, moet u ervoor zorgen dat de interne metalen profielen niet uitsteken en goed met elkaar zijn verbonden binnen de aluminium profielen.
- Stap 43:** De sticker moet op een schoon en droog oppervlak worden geplaatst.
- Stap 52:** Doe rustig aan en wees voorzichtig bij het inschuiven van de panelen.
- Stap 55:** Zorg ervoor dat de afstand tussen de aluminium profielen en goot van de muur identiek is voordat de schroeven aan de binnenkant worden vastgedraaid.
- Stap 72:** Zorg dat de schuur waterpas staat voordat u hem op het oppervlak van uw keuze verankert.  
Gebruik geschikte schroeven en pluggen (niet meegeleverd).

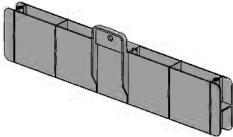
# Contents

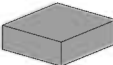
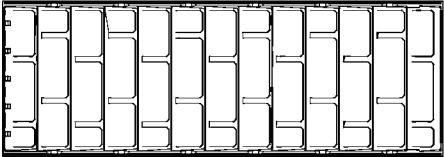
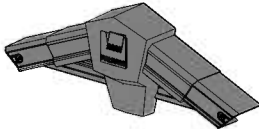

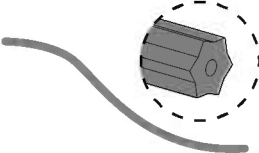
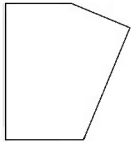

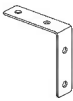
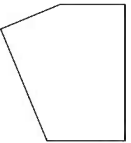

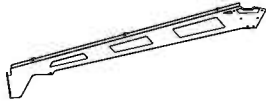
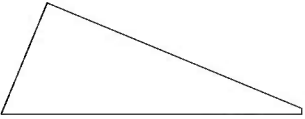
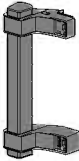
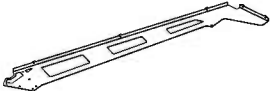
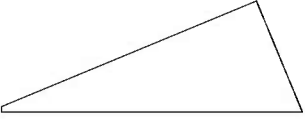
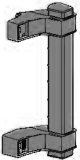



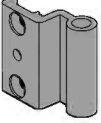

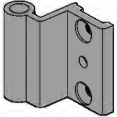

Item	Qty.	Item	Qty.	Item	Qty.
9472	2	9018	2	256	6
9474	1	8844	1	9020	2
9473	1	8842	1	9027	1
8840	4	8845	4	8867	4
9016	1	9468	1	8866	2
8846	4	9469	1	9620	2
8838	2	9470	4	9024	2
8839	17	8847	4	8854	1
		9471	6	8855	1
		8848	2		









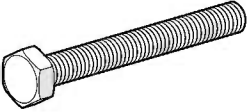



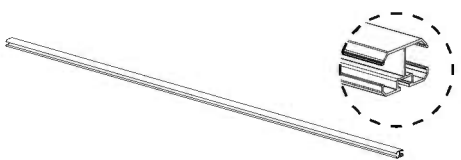
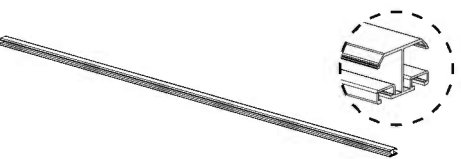

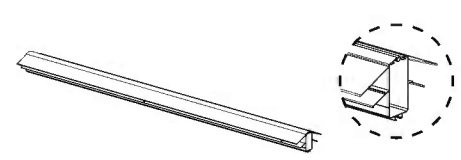
# Contents

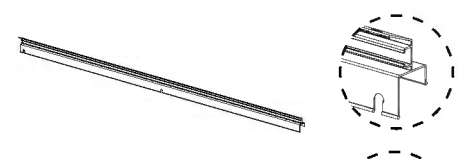
Item		Qty.	Item		Qty.	Item		Qty.	Item		Qty.
8858		6	9480		1	9622		1	7870		2
9029		8	9481		1	9621		1	9479		2
9467		2	7602		4	8786		4	8884		4
9466		8	8447		1	8785		2	8883		4
9030		8	8789		2	8779		1	8885		2
8862		2	8787		2	8778		1	8274		2
8863		2	8788		2	9227		10	9475		1
8860		2	8784		1				9476		1
8861		2	8783		1						

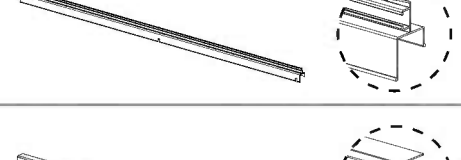
# Contents

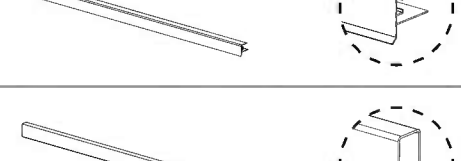
Item		Qty.	Item		Qty.
466		122 (+12)	7919		6
411		83 (+11)	7918		6
8192		29 (+3)	7921		6
97		6	7920		6
4045		76 (+7)	7923		12
7442		28 (+2)	7922		6
7524		28 (+2)	7924		24
4008		12 (+1)			
8635		4			

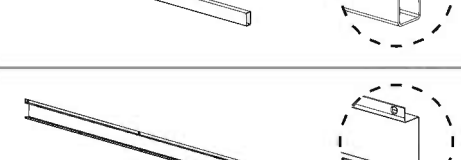
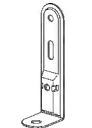
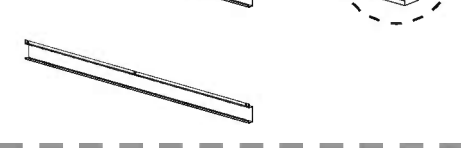
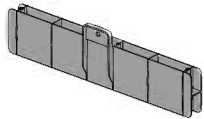

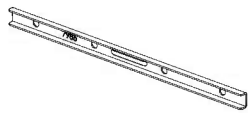
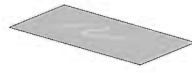
# Contents Extension Kit



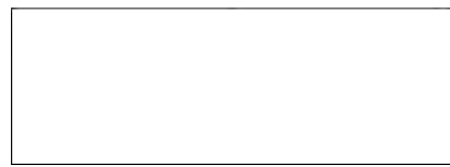
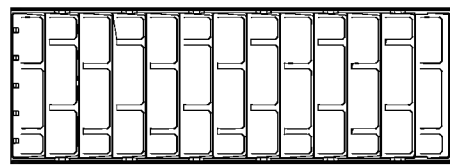

Item		Qty.	Item		Qty.
8839		4			
9023		4	466		42 (+2)
9017		1	411		36 (+2)
9022		1	8192		6
9021		1	4045		12 (+1)
9019		2	7442		16 (+1)
9028		1	9227		2
9025		1	8447		2
9026		1	7985		5
			100		2

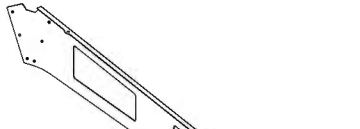

9029		4
9030		4

# Contents

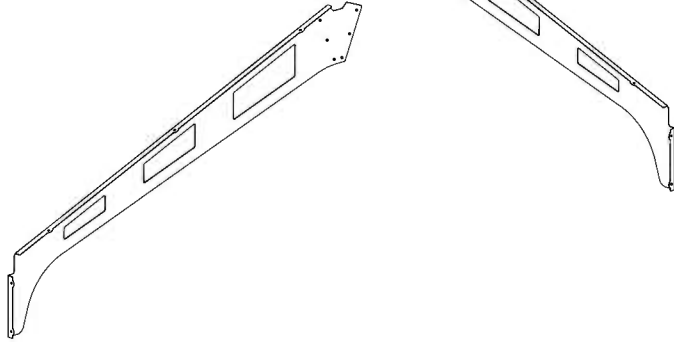
Item		Qty.	Qty.
		YUKON 11'x17'	YUKON 11'x21'
97		18 (+8)	24 (+2)
466		48 (+22)	64 (+6)
8192		30 (+14)	40 (+4)

Item			Qty.	Qty.
			YUKON 11'x17'	YUKON 11'x21'
9364			3	4
9365			3	4



1

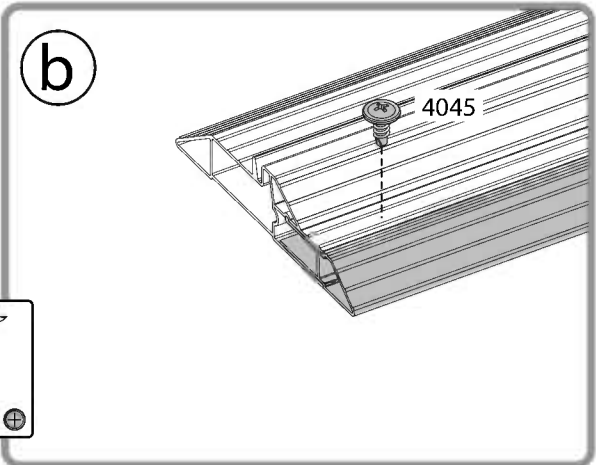
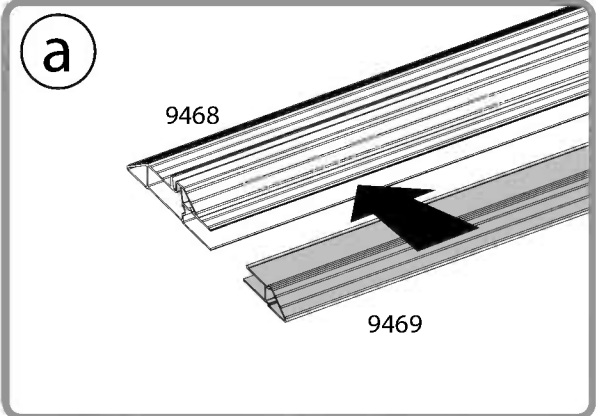
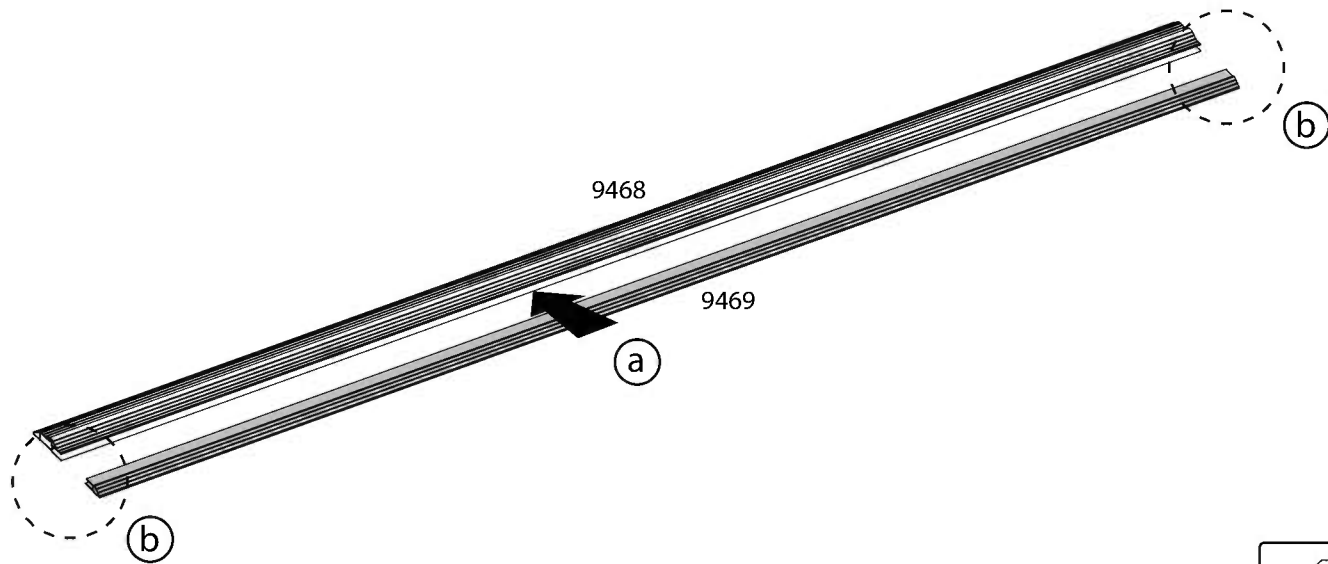
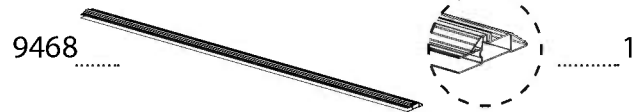

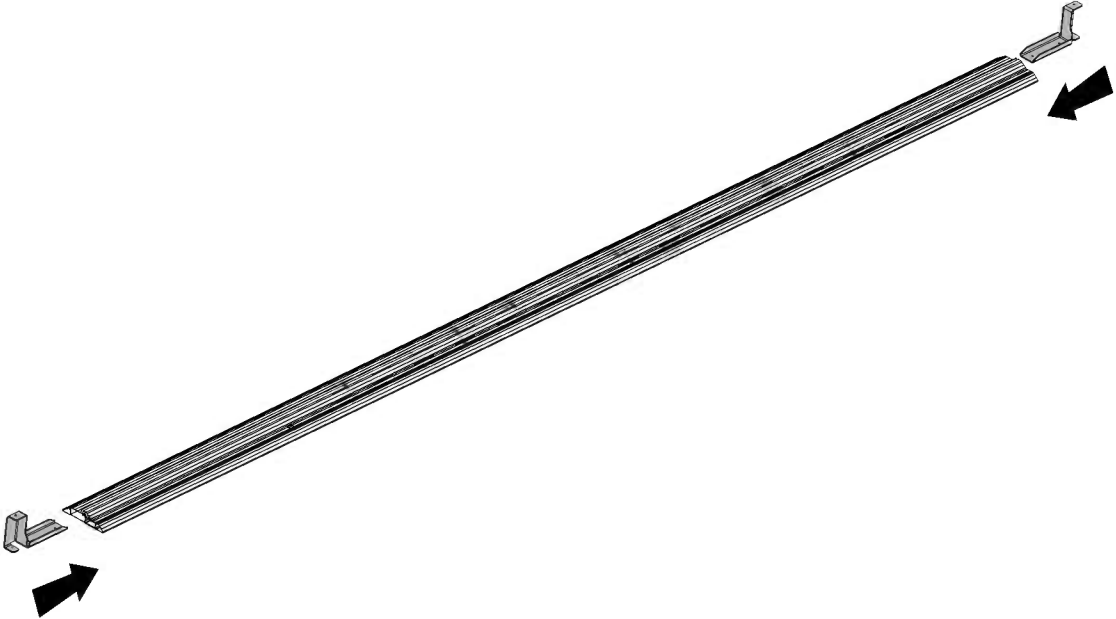
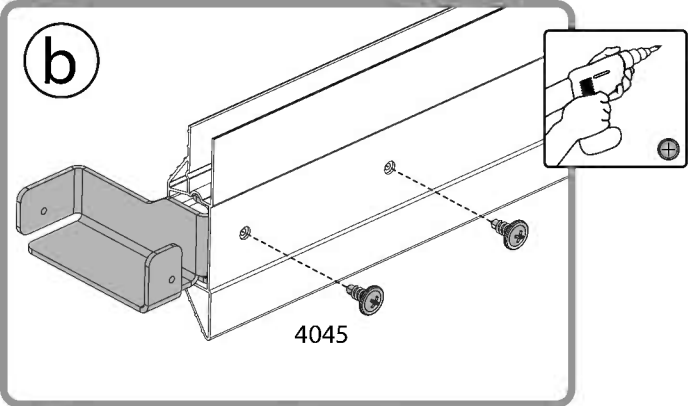
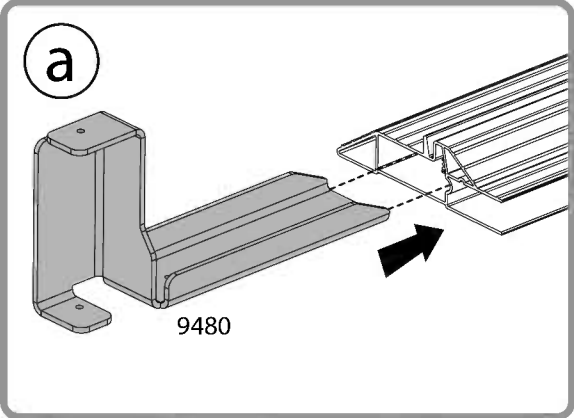
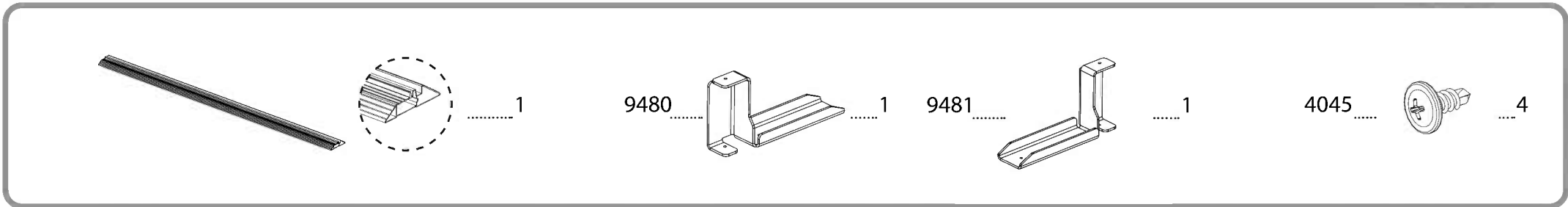
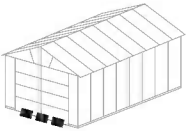

3

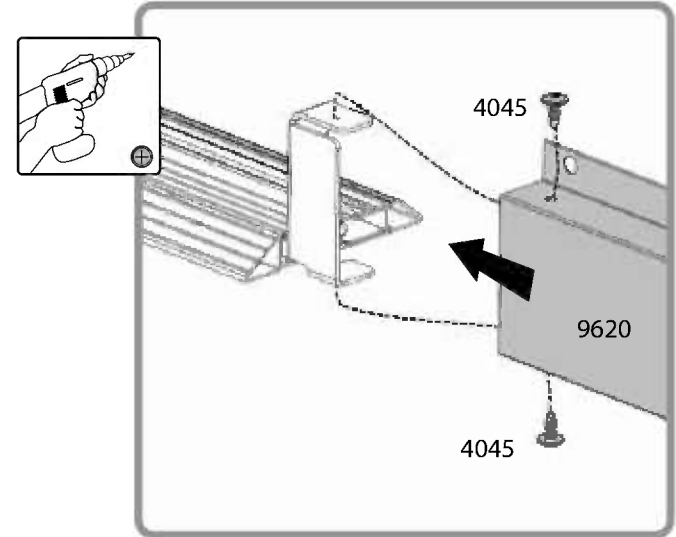
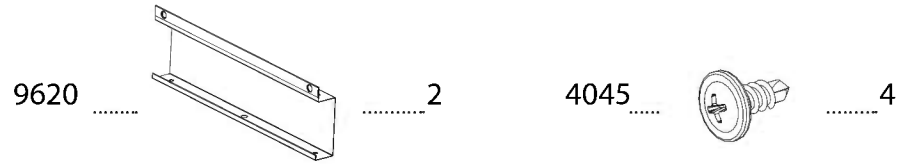

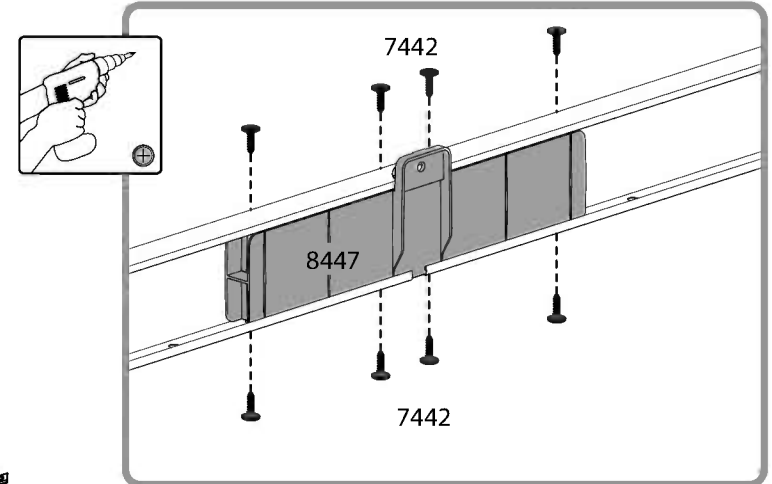
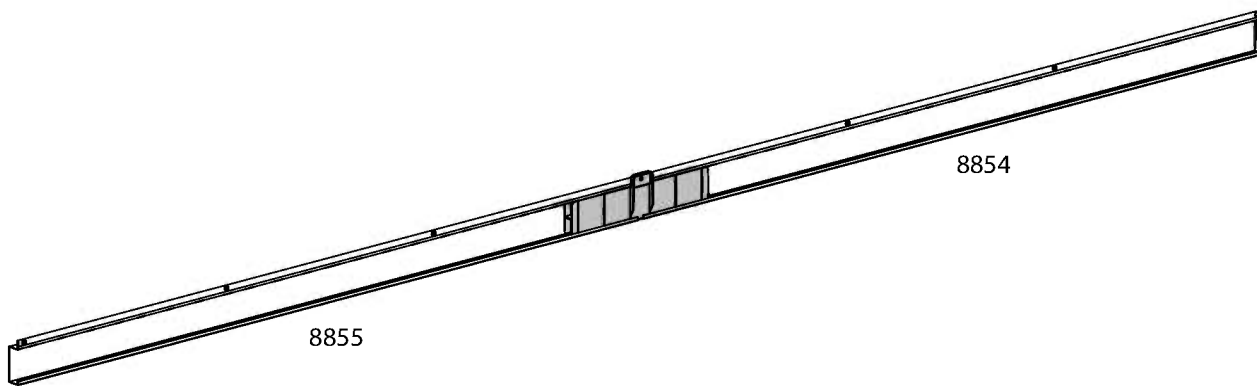
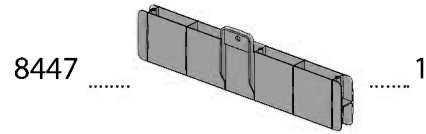
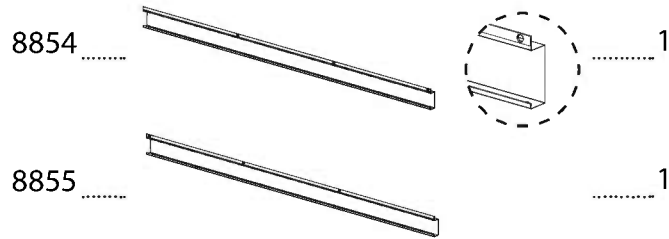
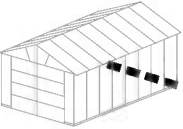



9024		2	9025		2	7442		32	<div style="border: 1px dashed gray; padding: 5px; display: inline-block;"> <p>11'x21'</p> </div> <table border="0" style="margin-left: 10px;"> <tr><td>9024.....</td><td>2</td></tr> <tr><td>9025.....</td><td>3</td></tr> <tr><td>9026.....</td><td>3</td></tr> <tr><td>7442.....</td><td>48</td></tr> <tr><td>8447.....</td><td>6</td></tr> </table>	9024.....	2	9025.....	3	9026.....	3	7442.....	48	8447.....	6
9024.....	2																		
9025.....	3																		
9026.....	3																		
7442.....	48																		
8447.....	6																		
			9026		2	8447		4											

9024, 9025, 9026

**11'x17'**  
11'x9' + 2 Extension kits

9024, 9025, 9026

**11'x21'**  
11'x9' + 3 Extension kits

7442, 8447, 7442



- 7602 ..... 4
- 7442 ..... 16

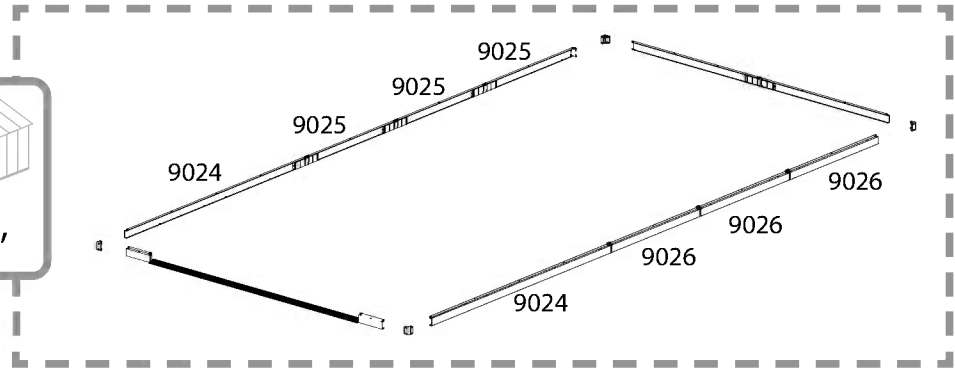
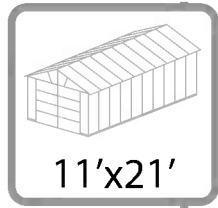
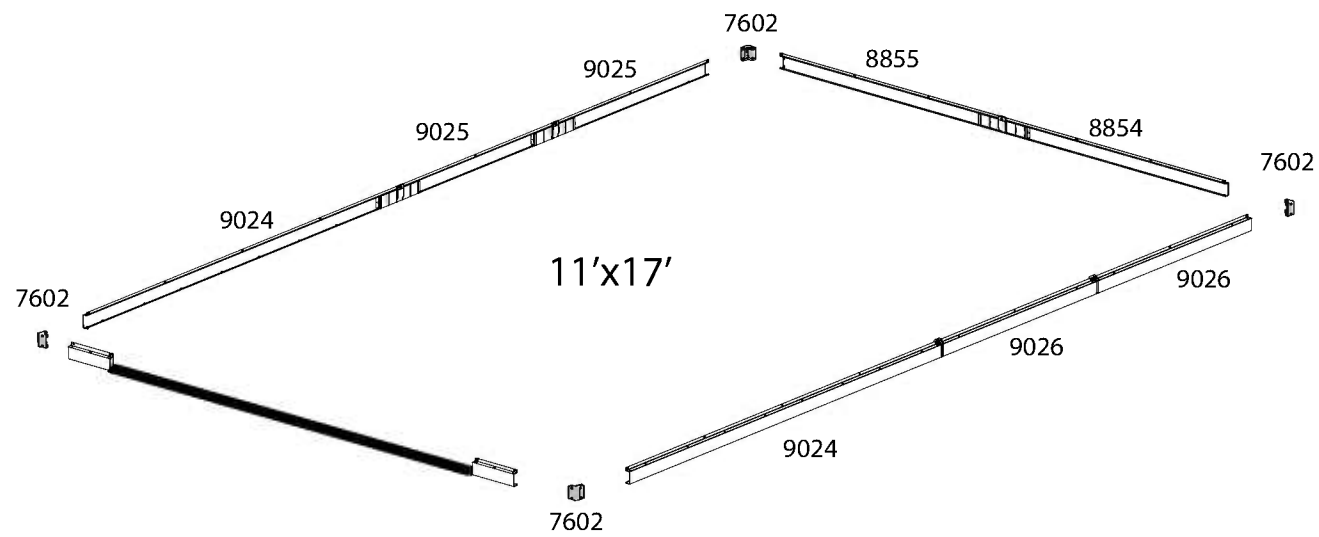
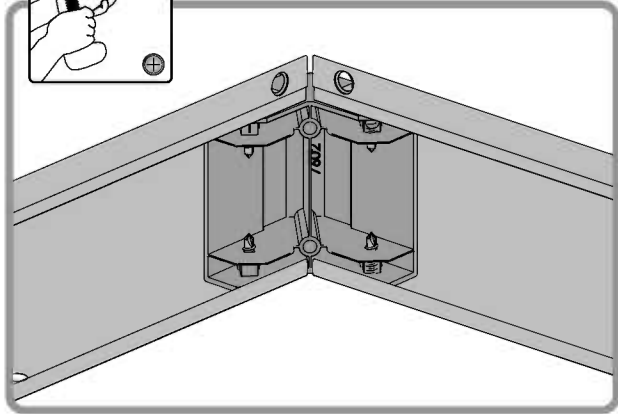
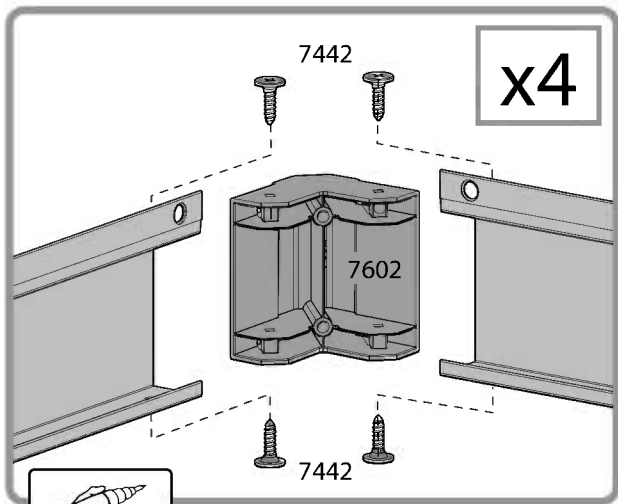

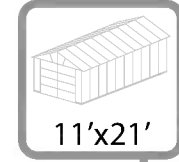
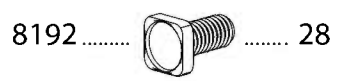

8856/9227 ..... 16
8192 ..... 32
466 ..... 32

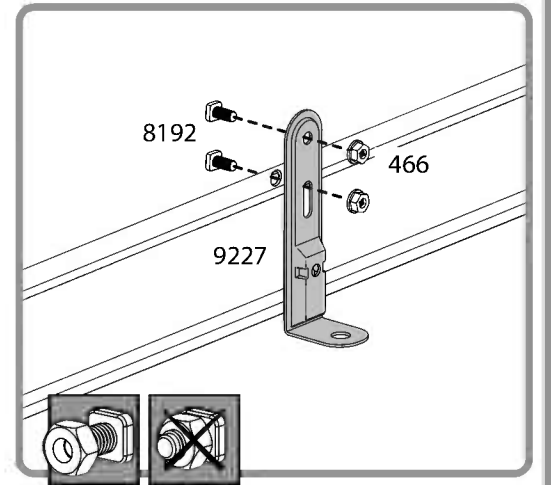
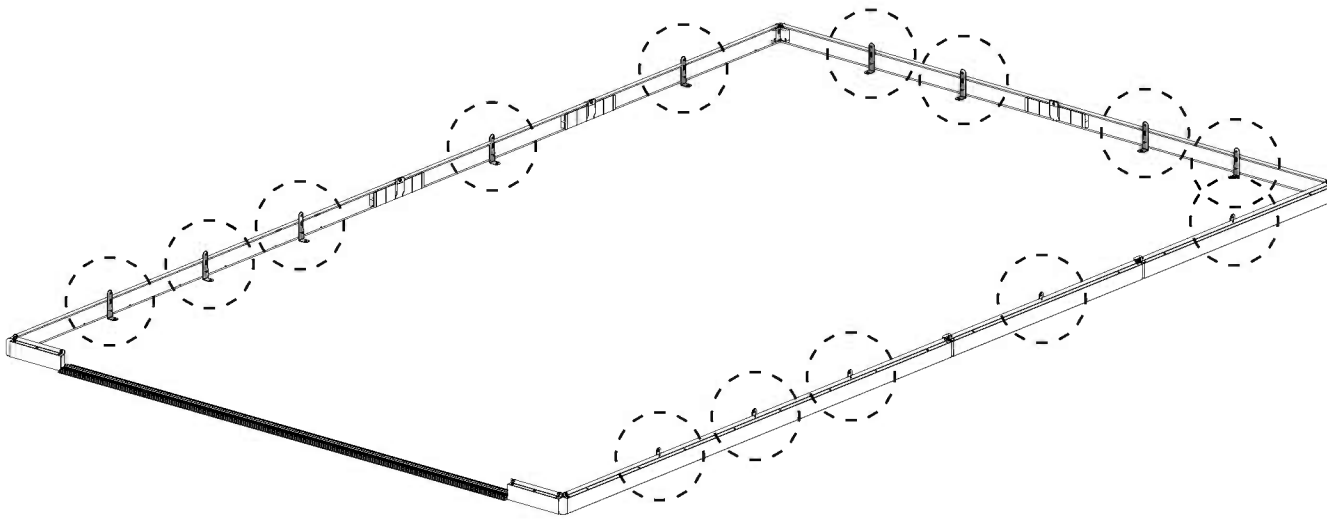



8192 ..... 5

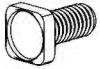

466 ..... 5

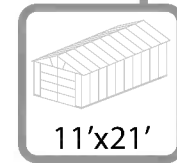

11'x21'

8192 ..... 7

466 ..... 7

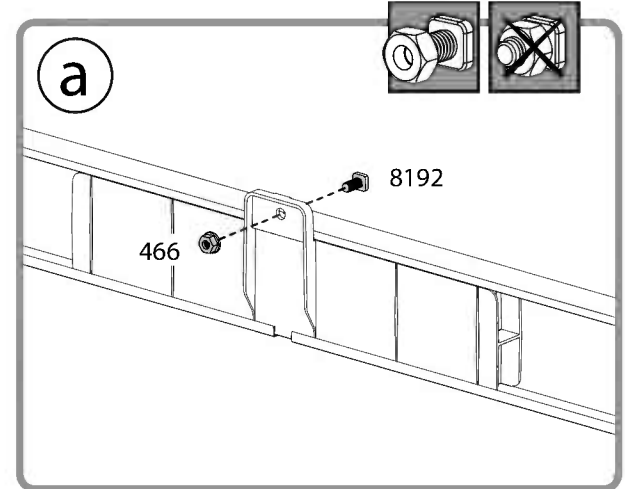
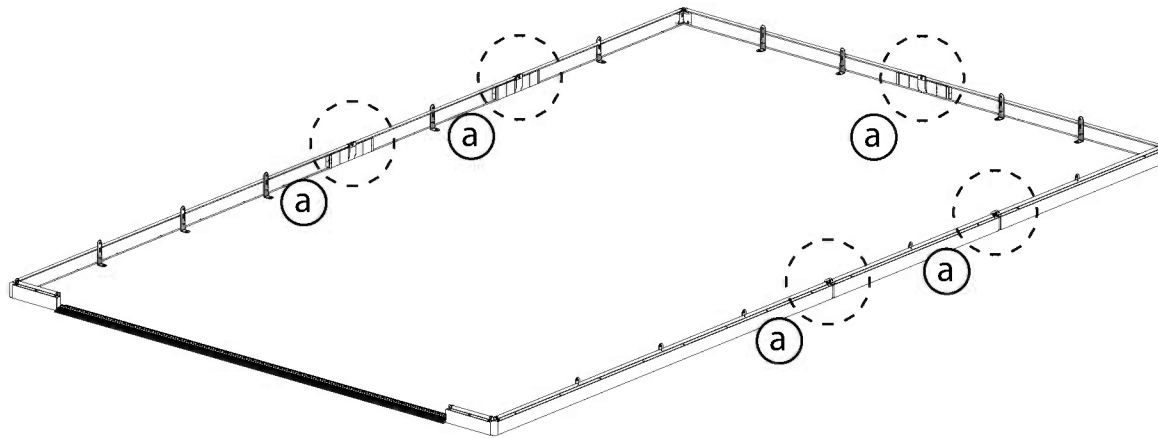



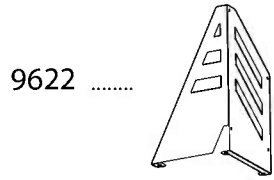
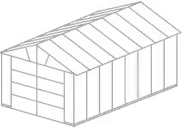

..... 1

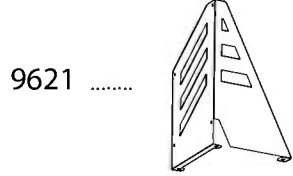

..... 1

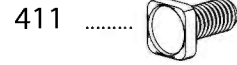



..... 8

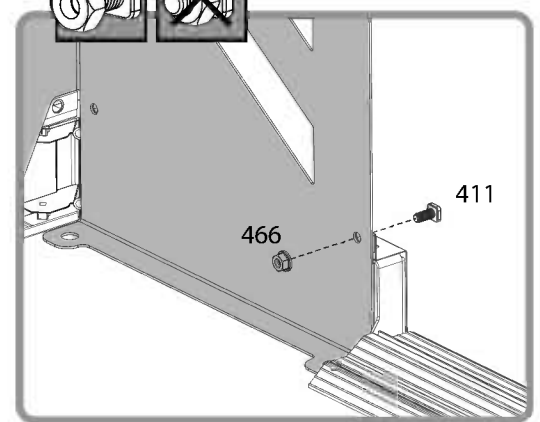
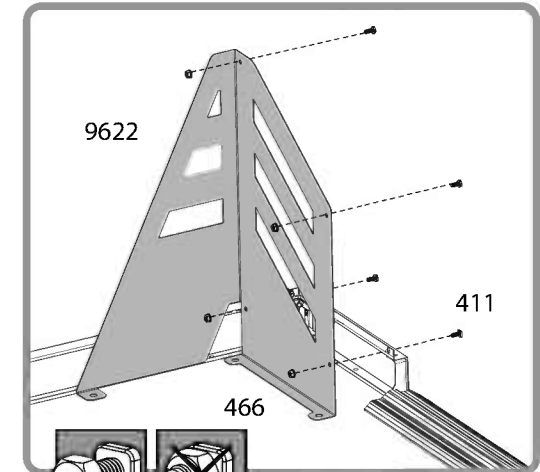
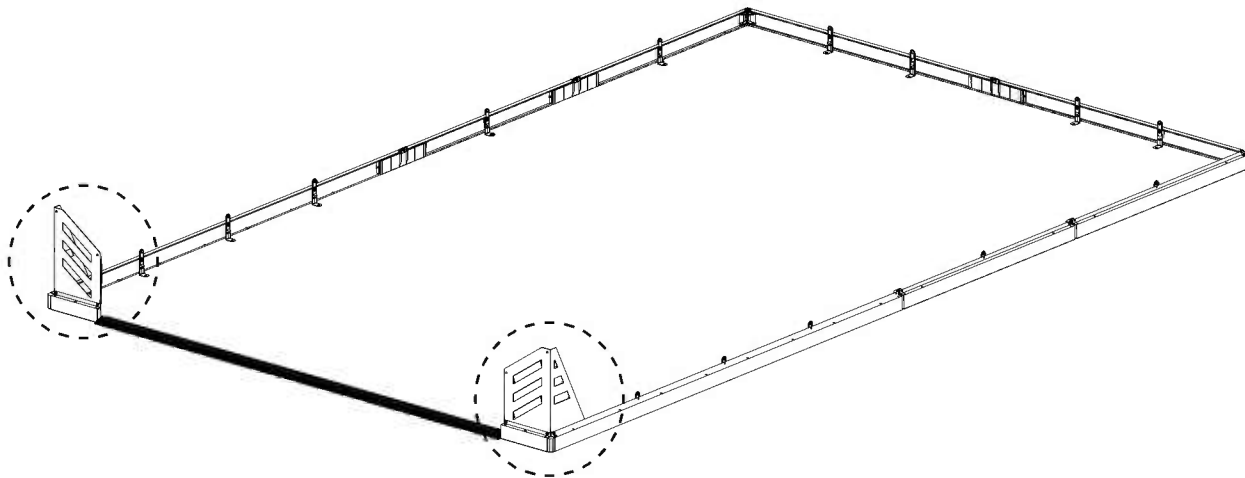

..... 8

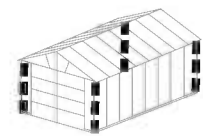

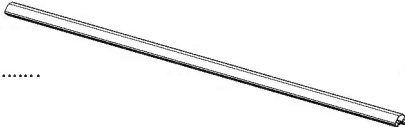

- 8840 .....  ..... 4      411 .....  ..... 6      466 .....  ..... 6

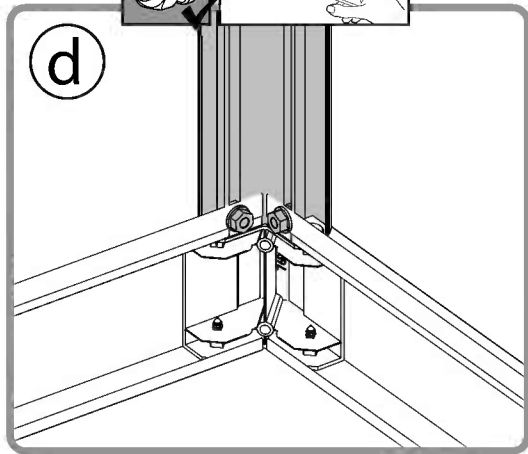
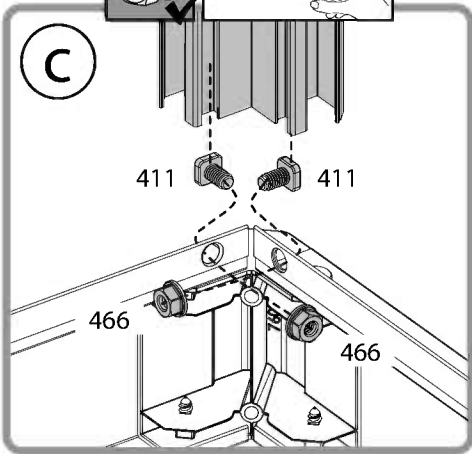
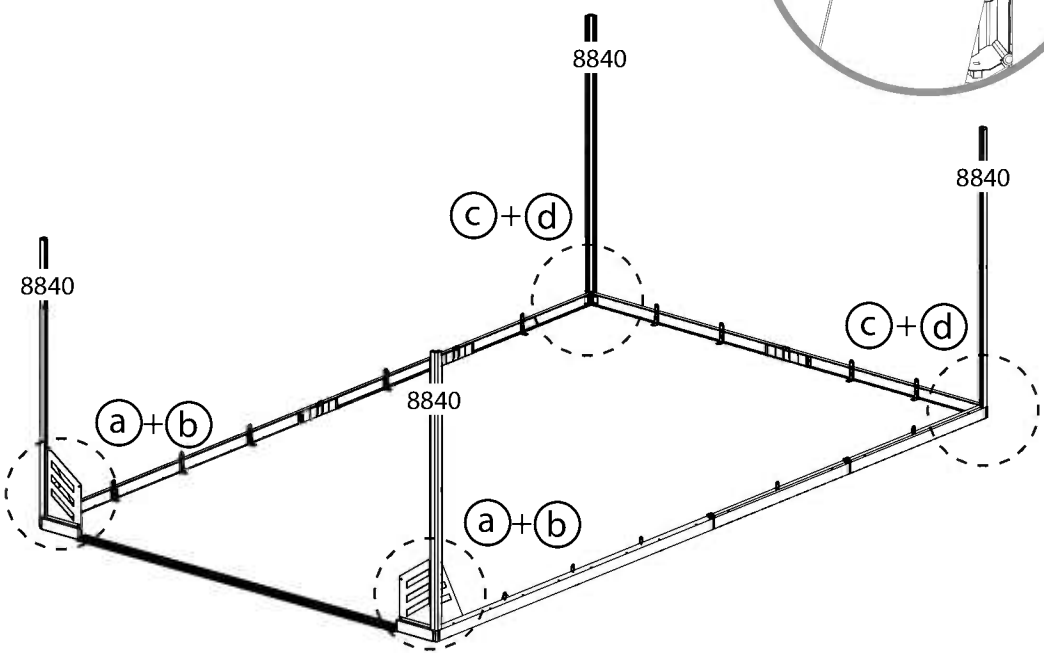
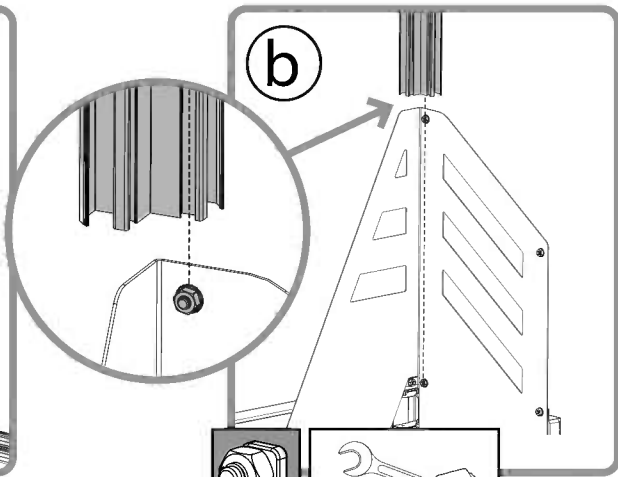
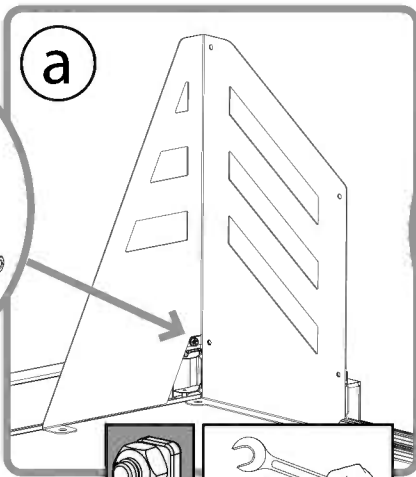
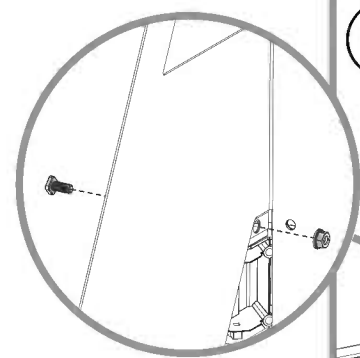

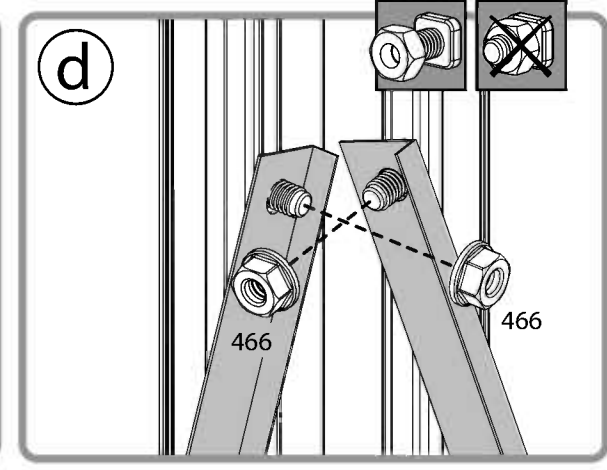
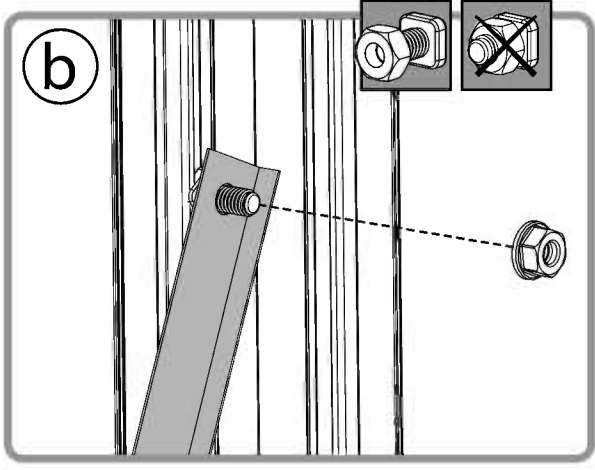
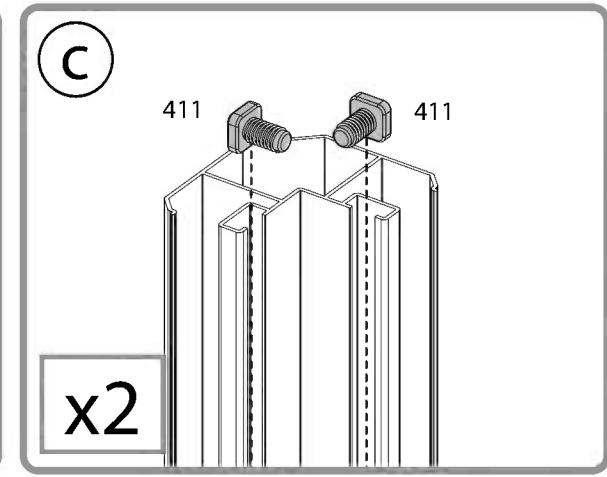
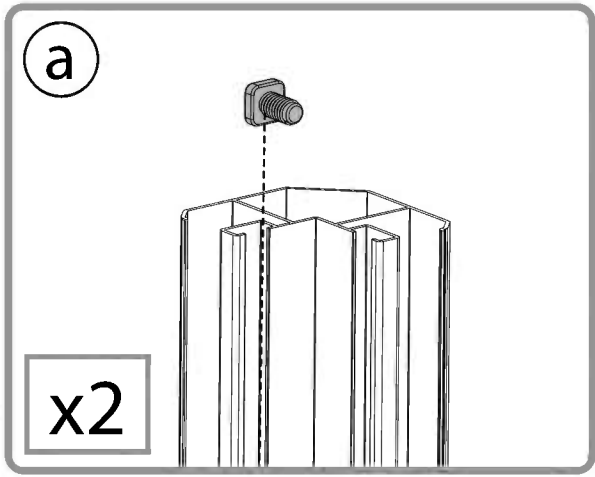
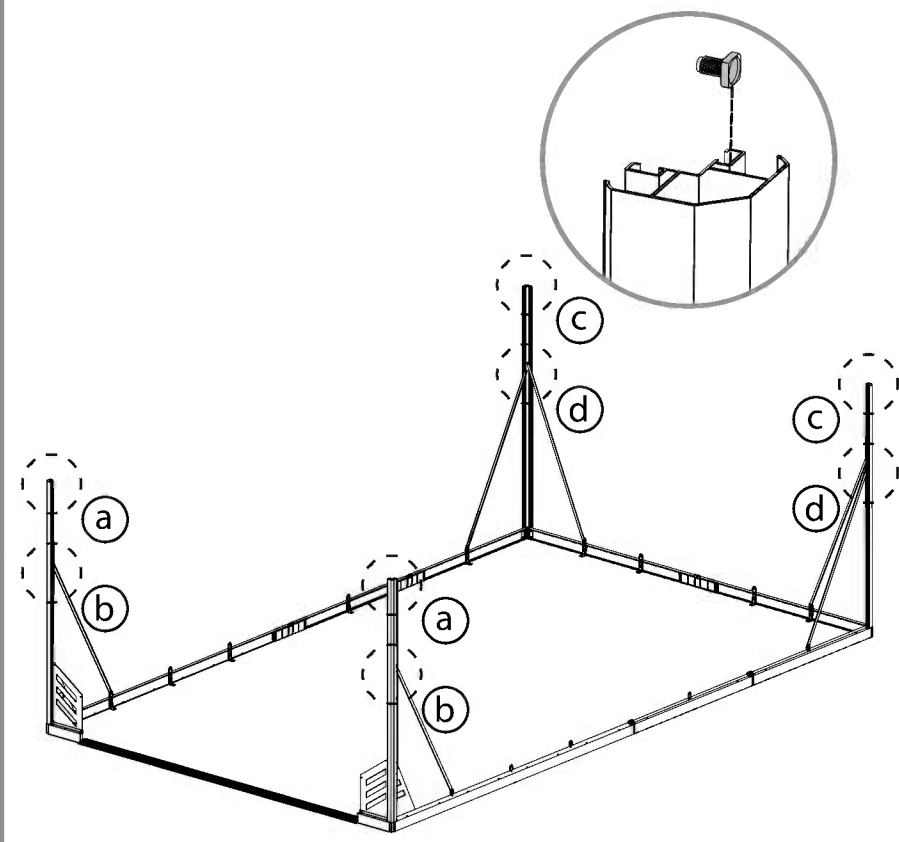
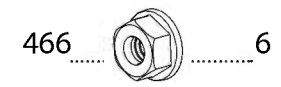
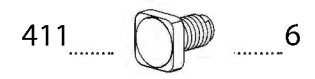
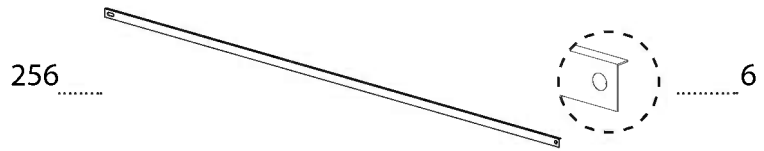
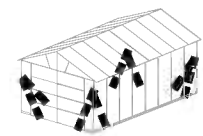

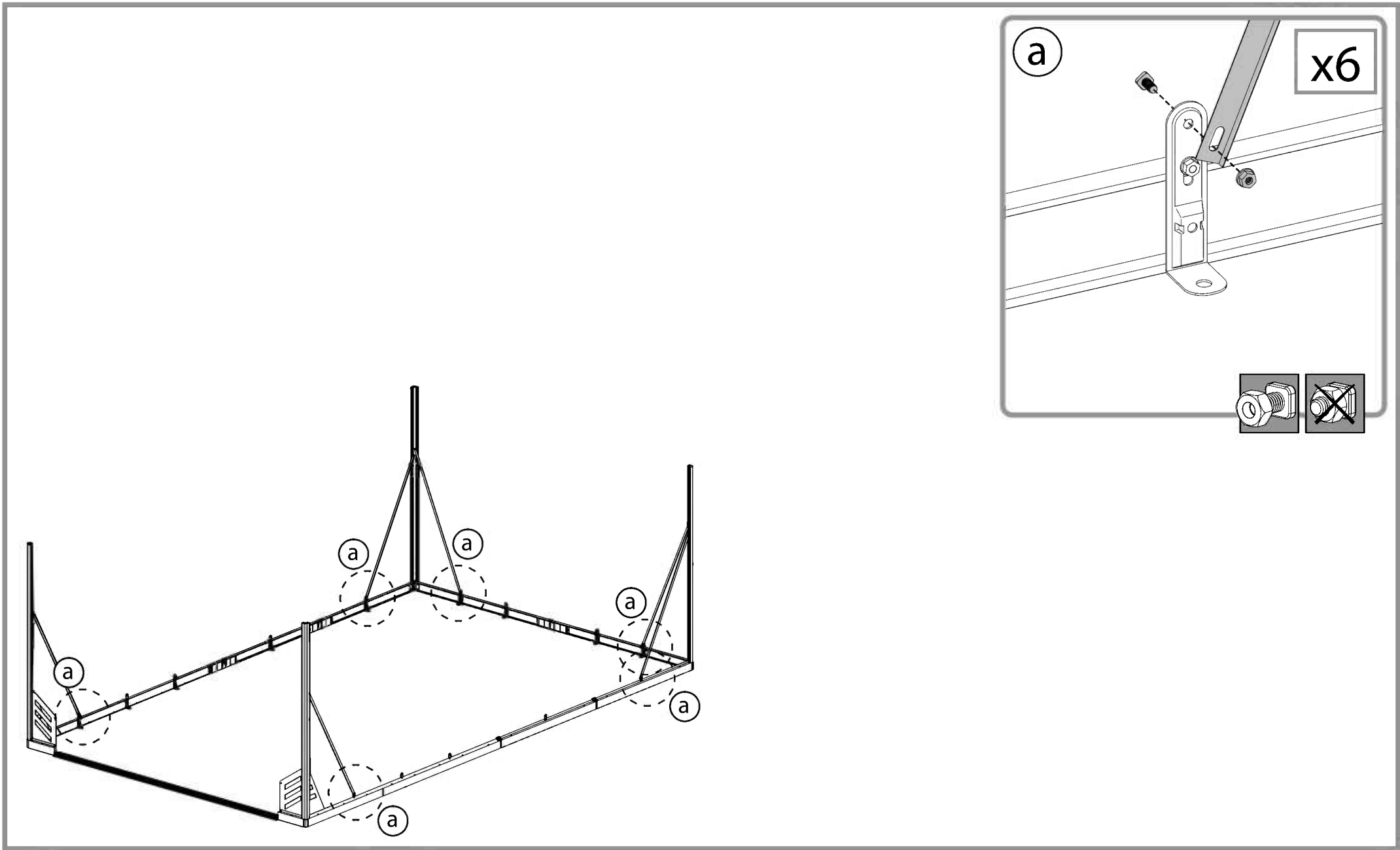
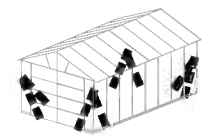



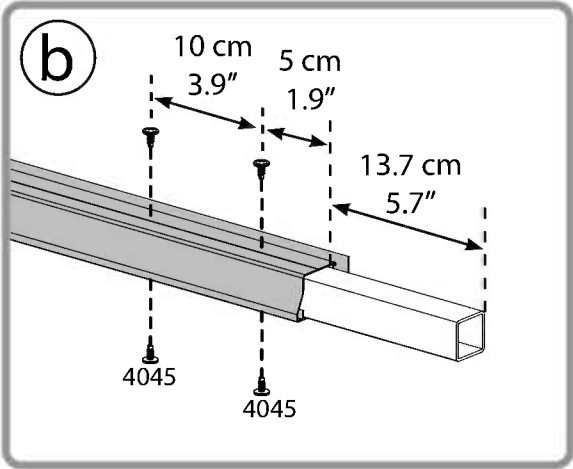
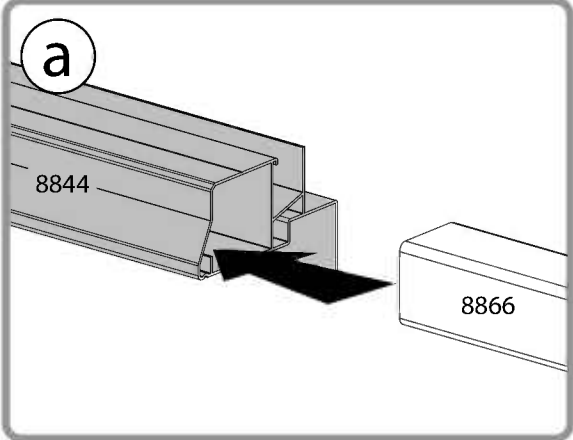
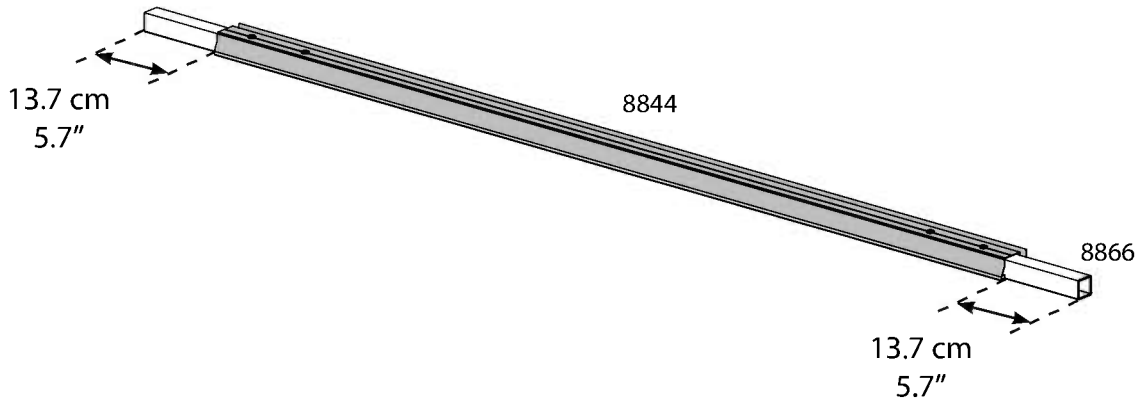
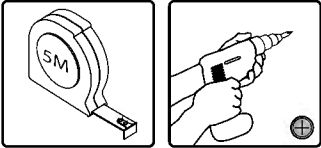
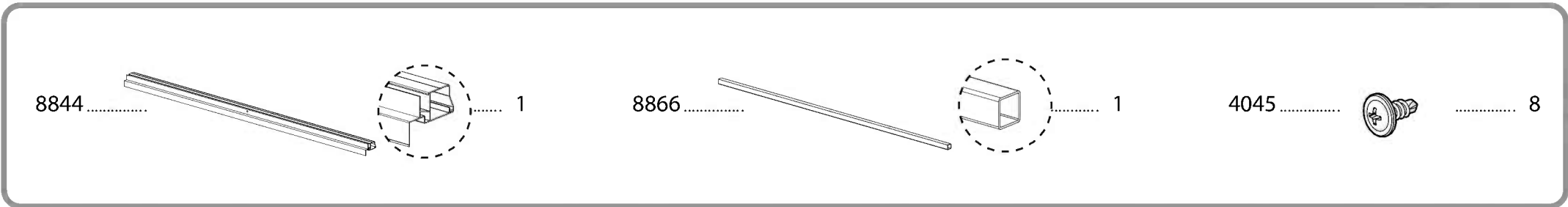
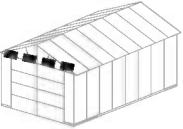

**a**

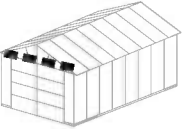
**x6**



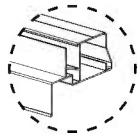

8845 .....   ..... 2

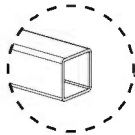
8867 .....   ..... 2

4045 .....  ..... 12

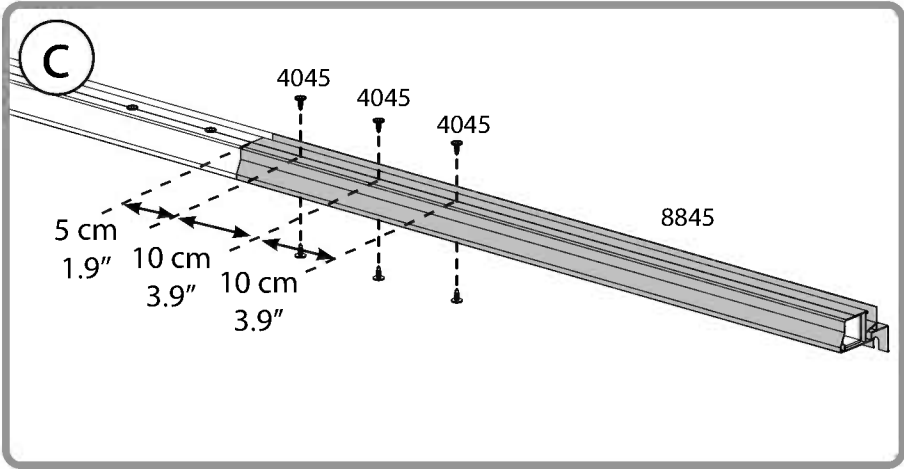
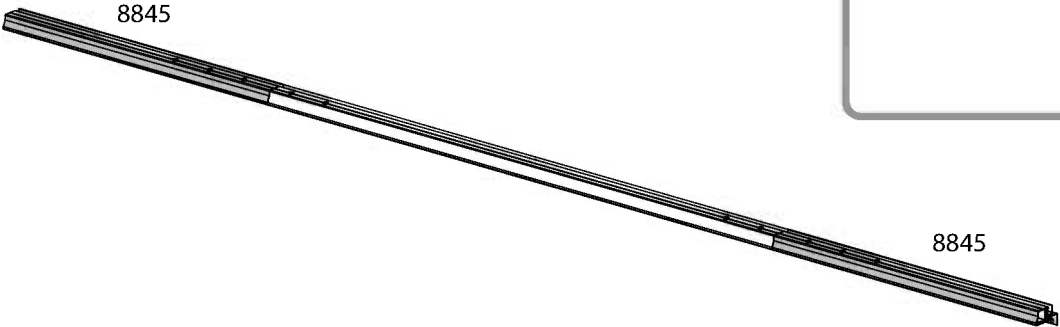
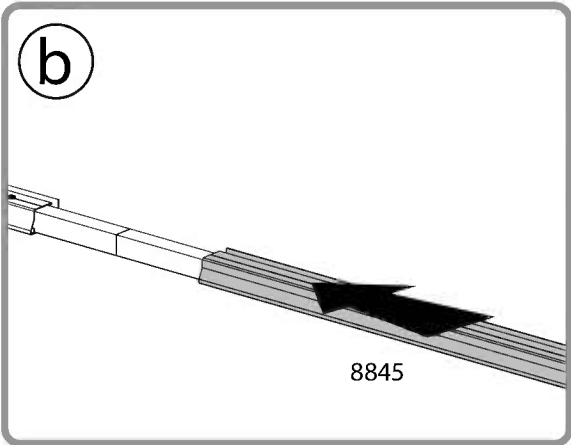
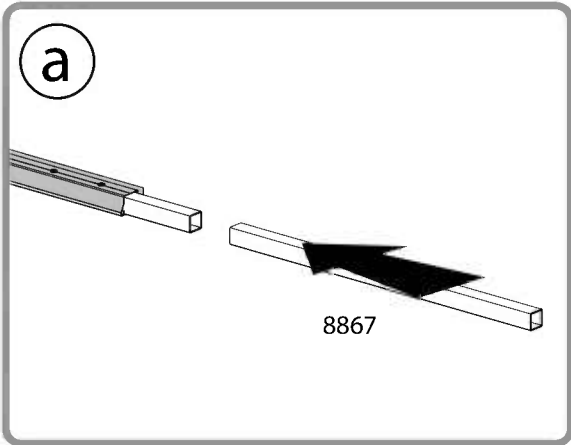
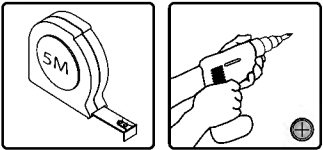

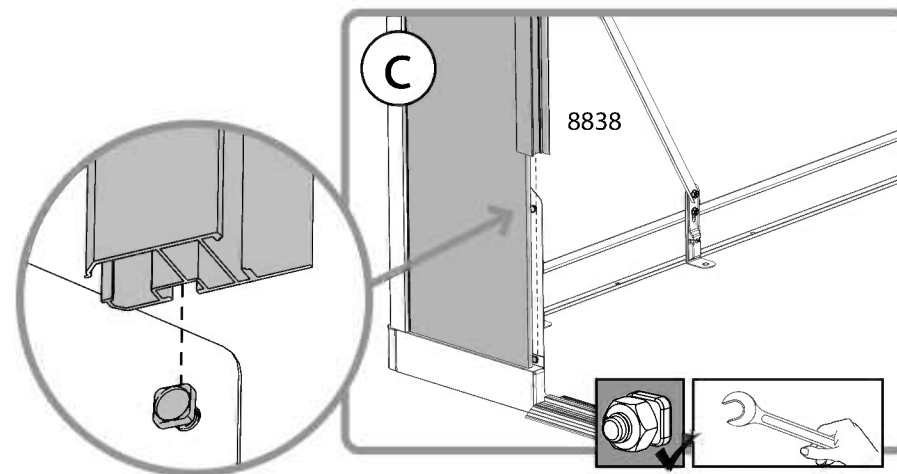
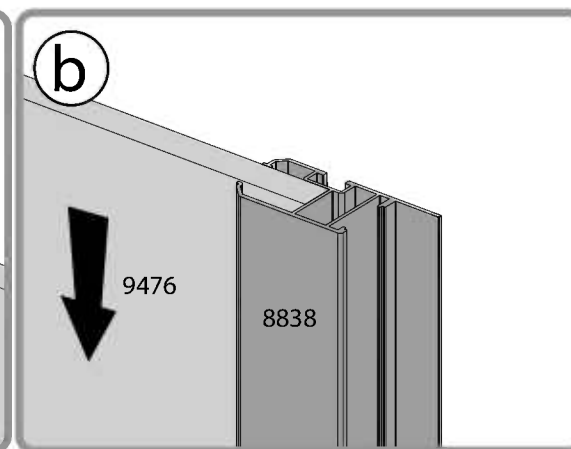
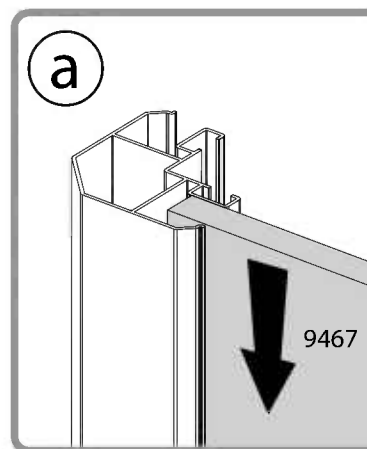
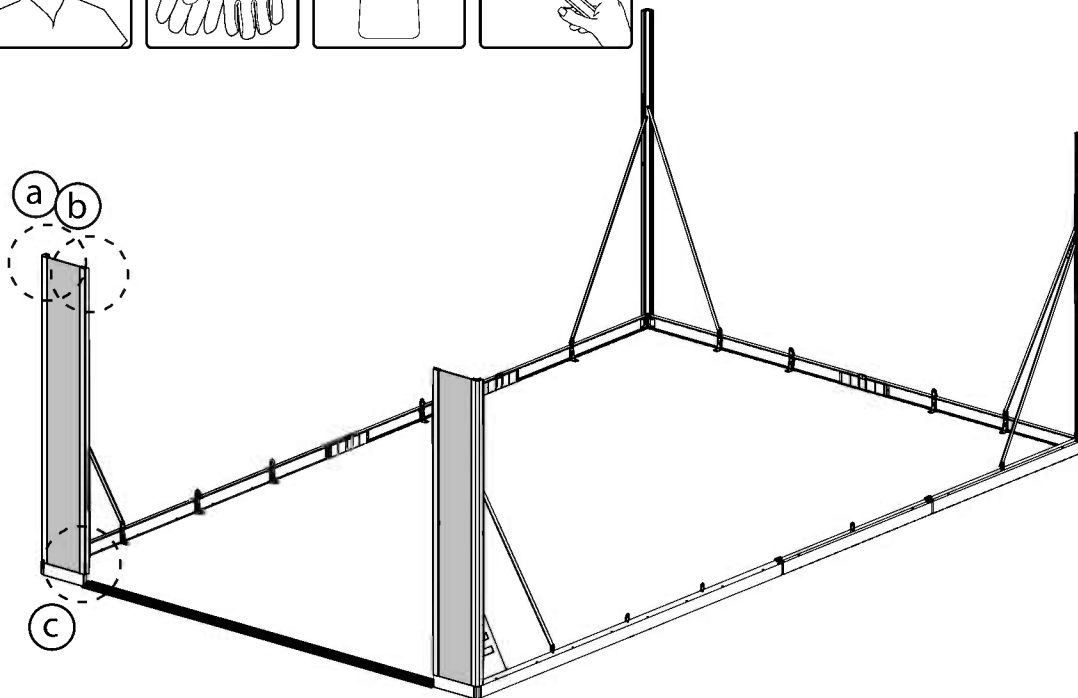
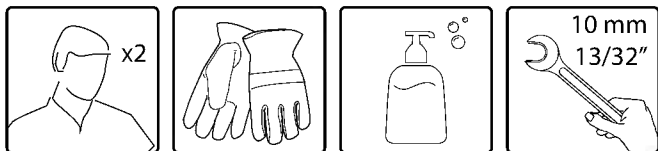
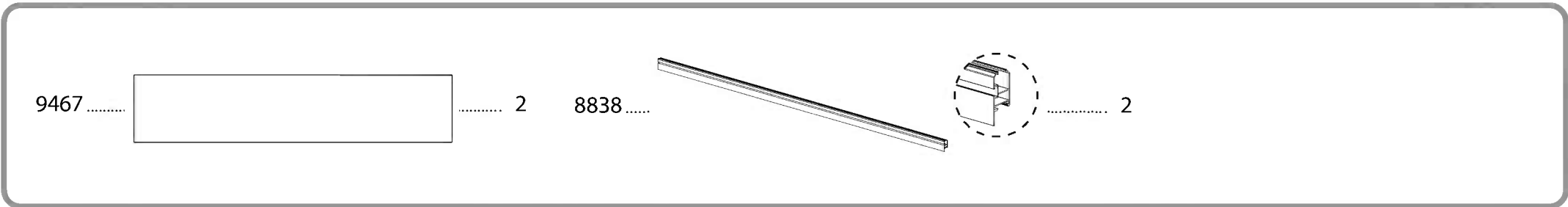
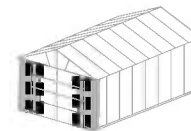

**EN** Matte side of the panel should face out  
**DE** Die matte Seite aller Produktplatten sollte nach immer außen verlegt werden  
**FR** Le côté mat de tous les panneaux du produit devrait être tourné vers l'extérieur  
**SP** El lado mate de todos los paneles del producto debe estar mirando hacia afuera

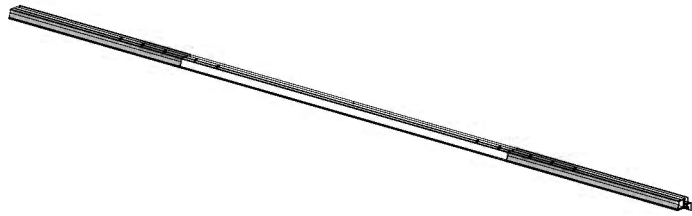
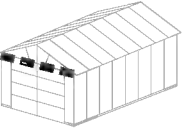

8192 ..... 2

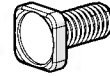

411 ..... 6



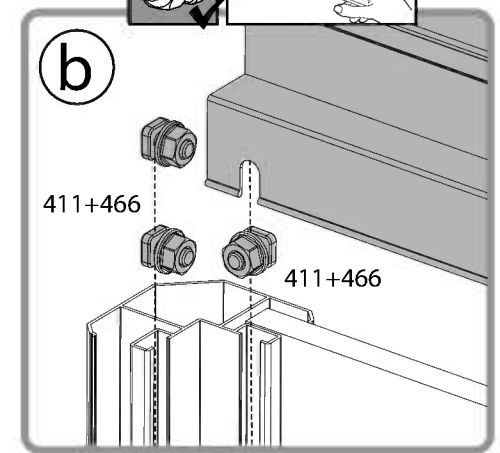
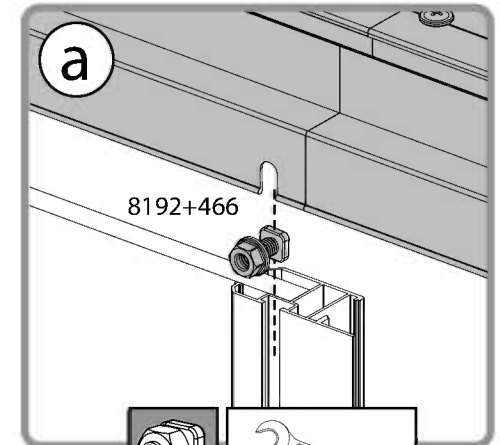
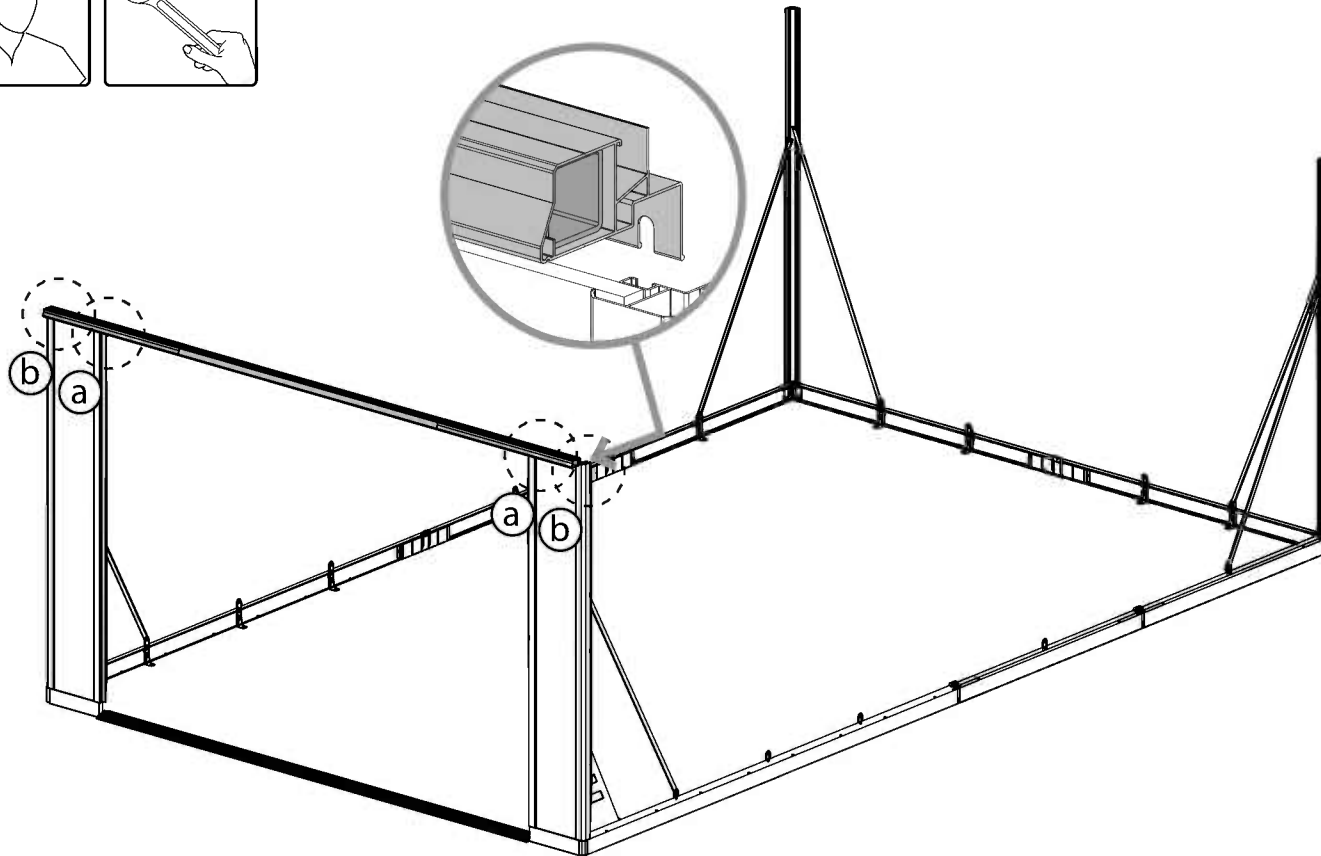
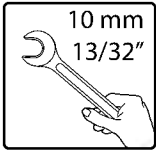

466 ..... 8



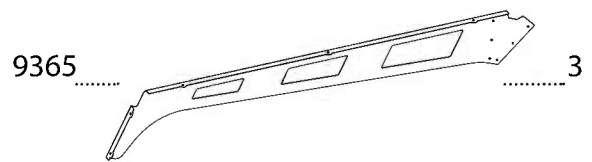
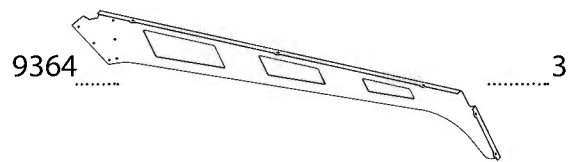
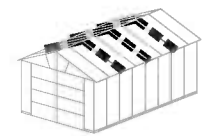



- 97 .....  ..... 18
- 466 .....  ..... 18

 11'x21'	9364 ..... 4
	9365 ..... 4
	97 ..... 24
	466 ..... 24

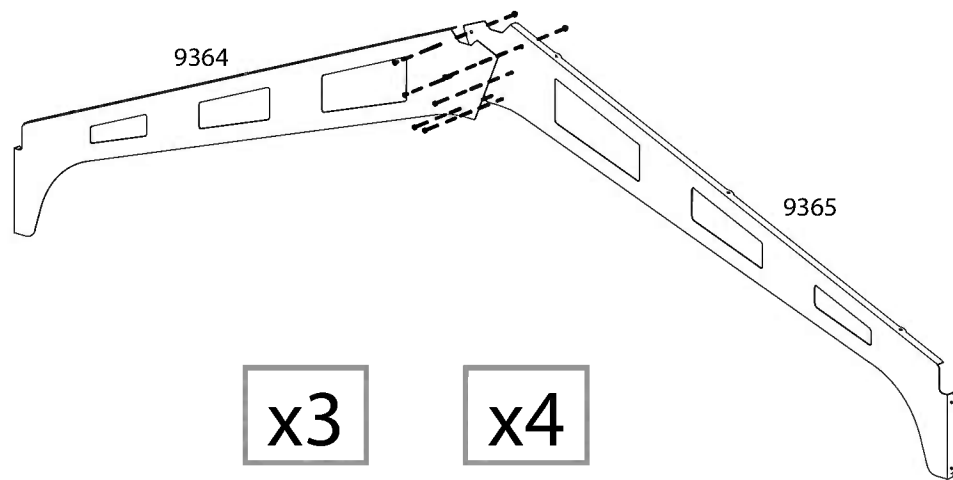
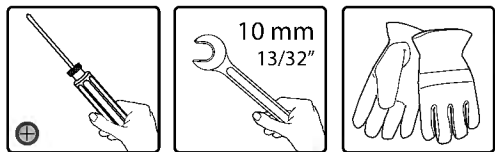

**x3**

11'x17'

**x4**

11'x21'

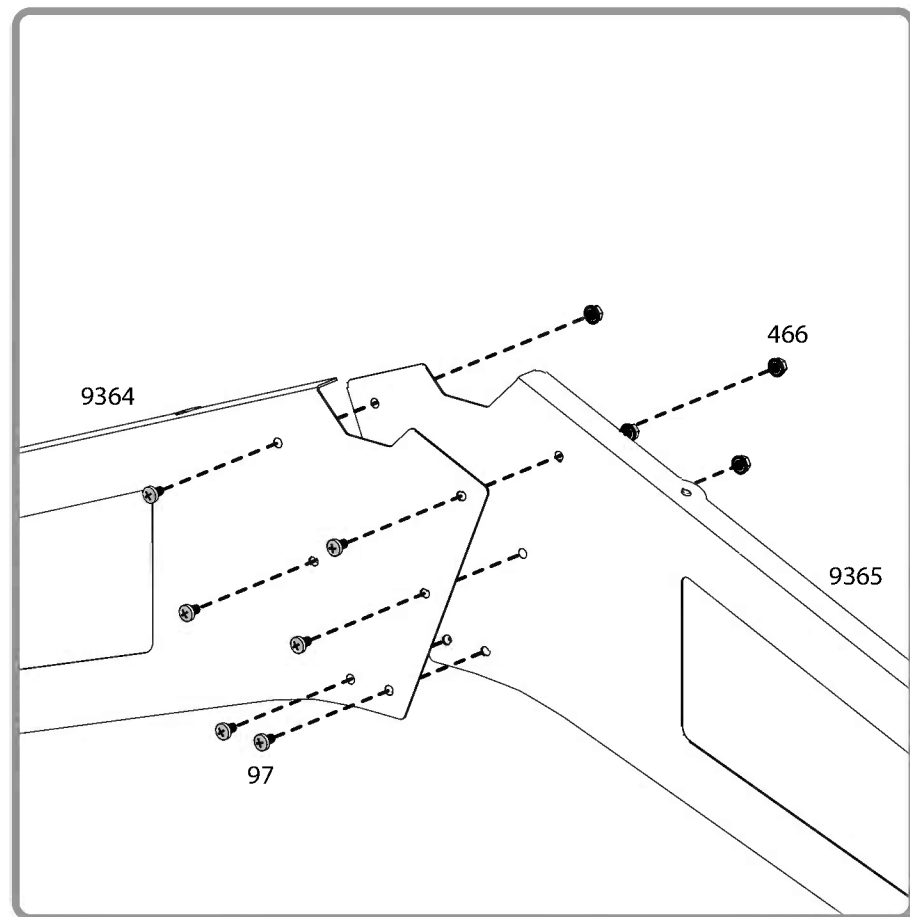

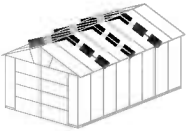

8192 .....  ..... 18

466 .....  ..... 18

 11'x21'	8192 ..... 24
	466 ..... 24

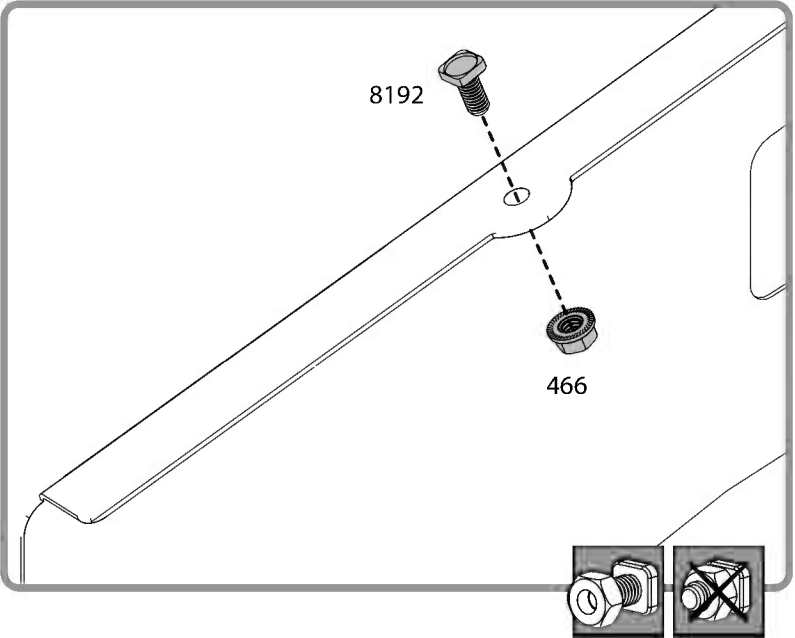
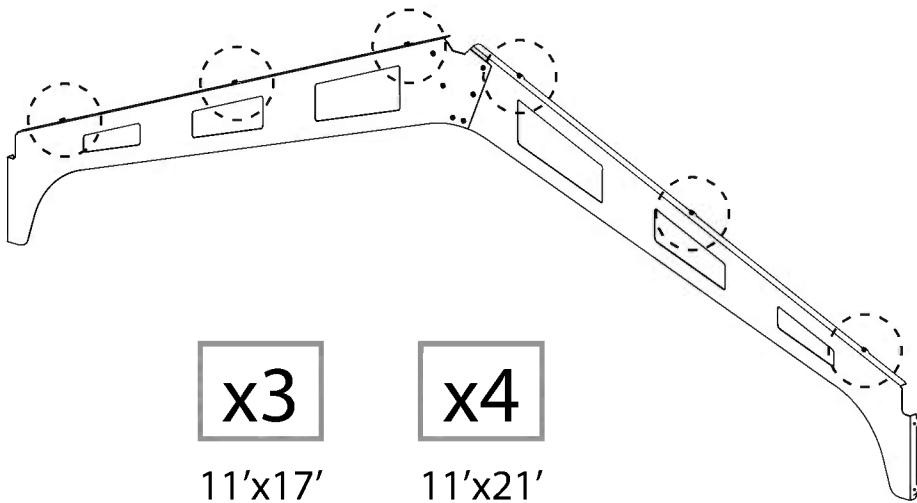
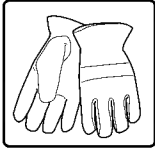

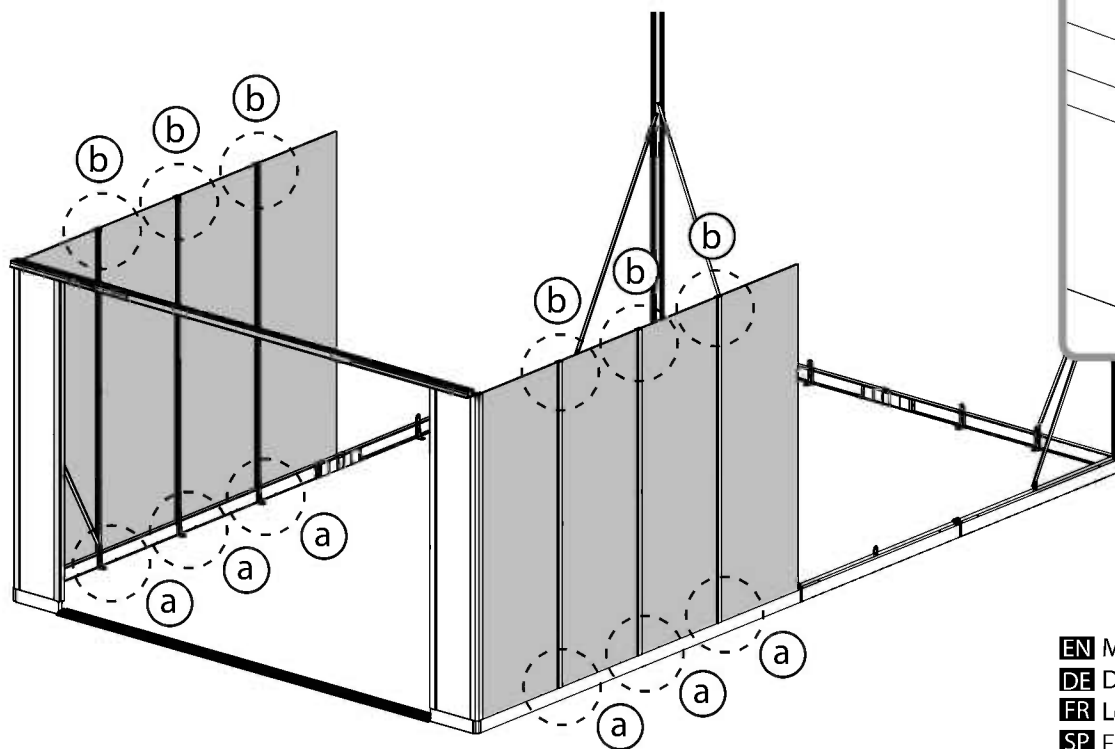
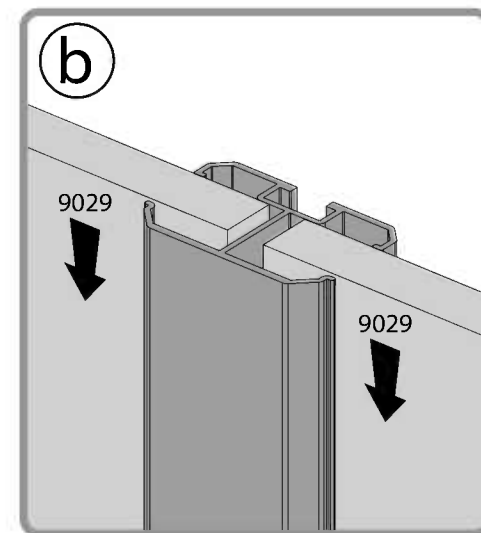
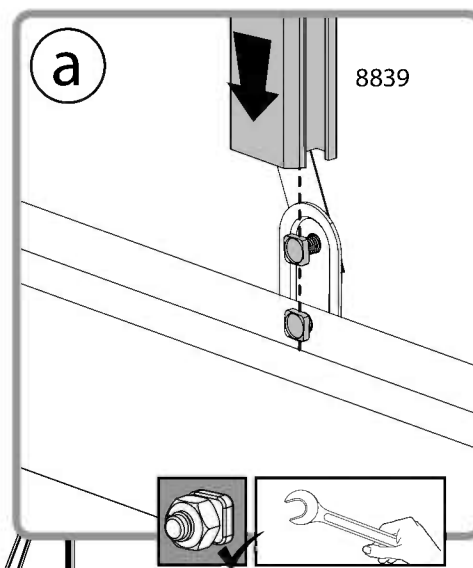
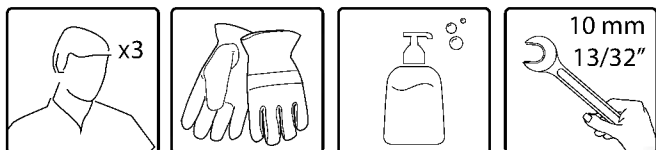
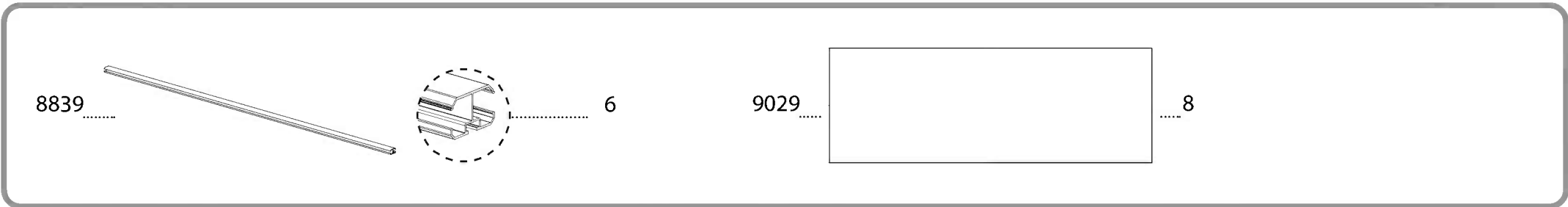
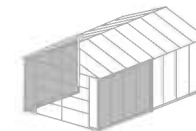

**EN** Matte side of the panel should face out  
**DE** Die matte Seite aller Produktplatten sollte nach immer außen verlegt werden  
**FR** Le côté mat de tous les panneaux du produit devrait être tourné vers l'extérieur  
**SP** El lado mate de todos los paneles del producto debe estar mirando hacia afuera

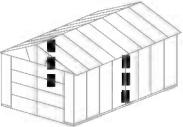

9023

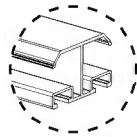
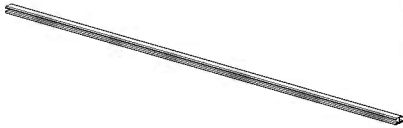

2

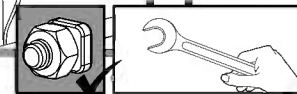
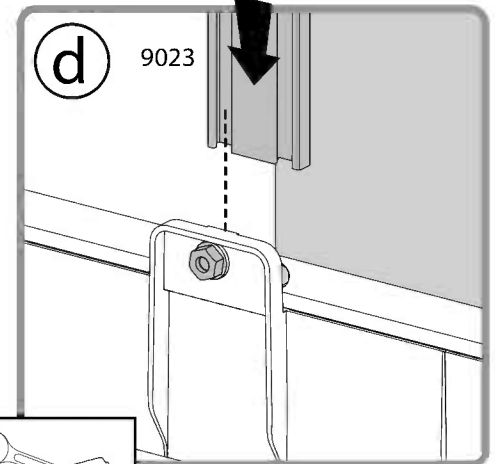
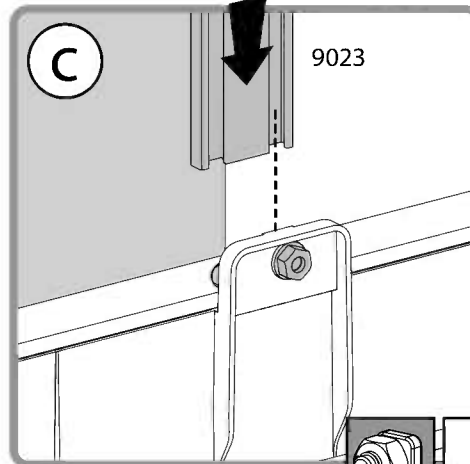
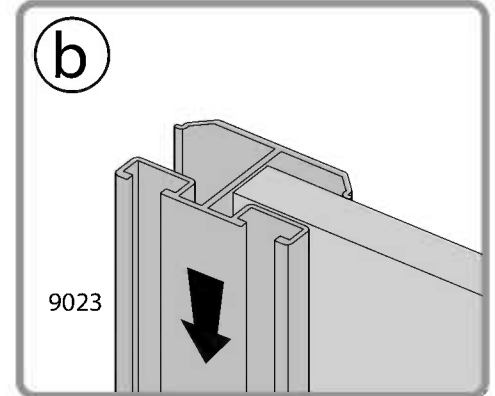
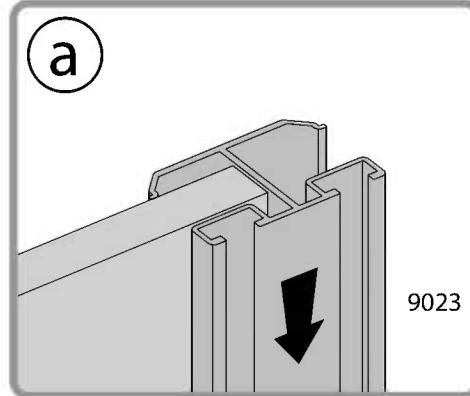
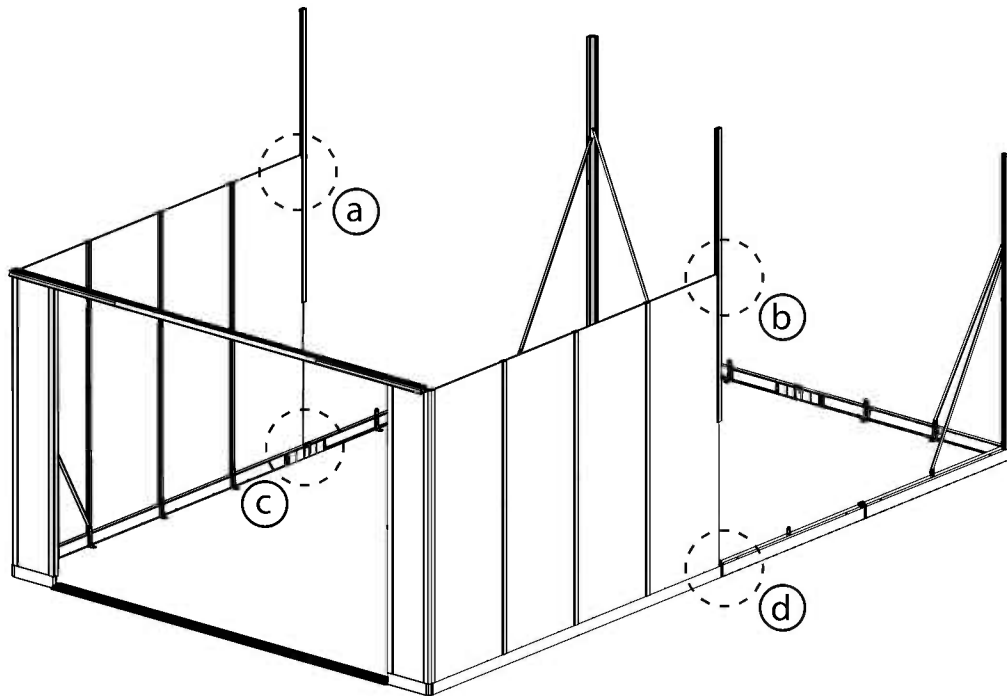
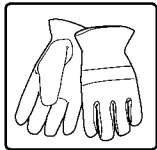
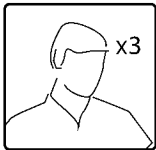
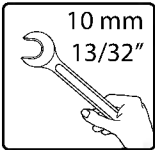

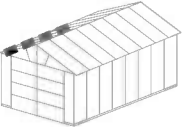

9020 .....

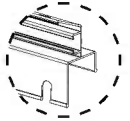
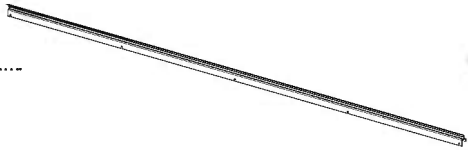

..... 1

411 .....



..... 5

466 .....



..... 5

8192 .....



..... 4

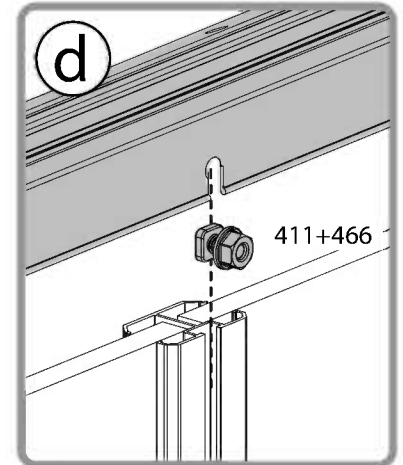
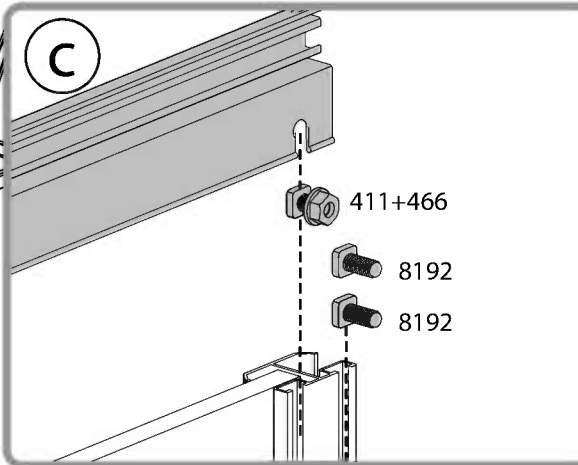
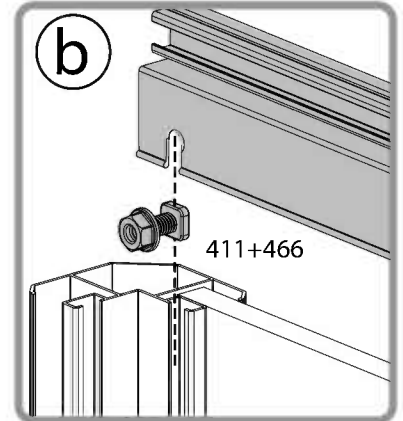
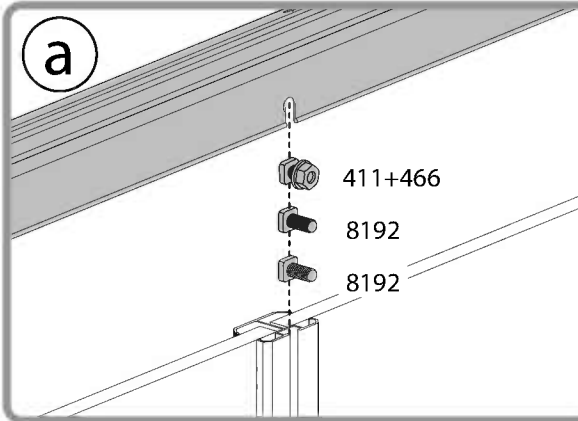
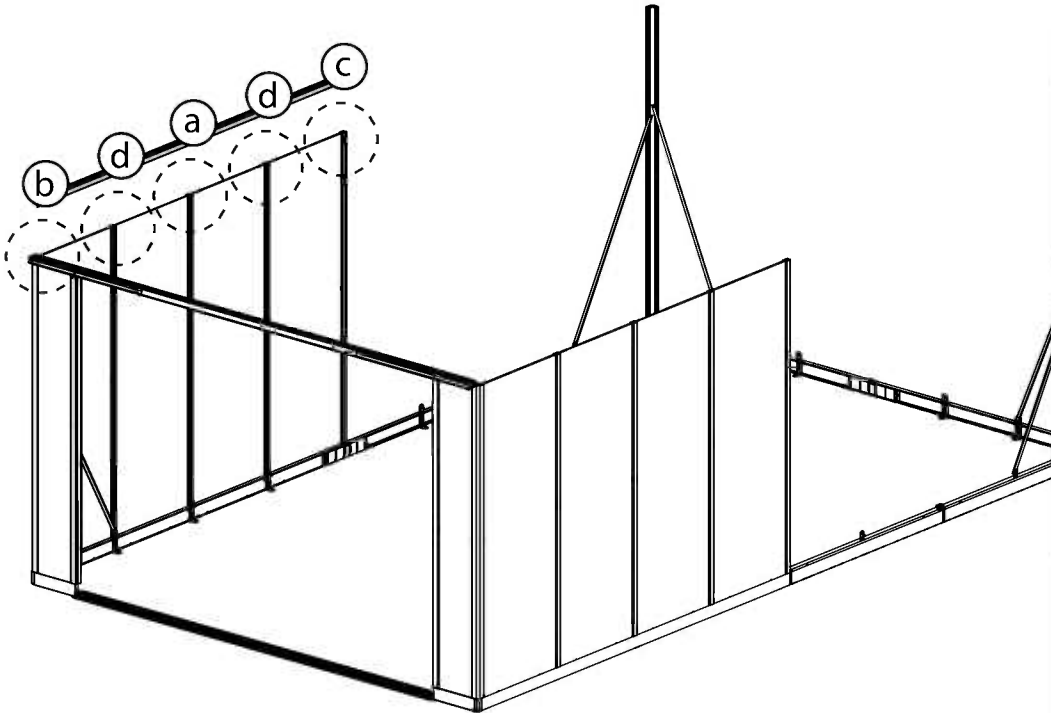
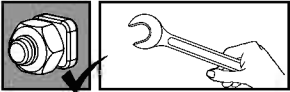



9020 .....

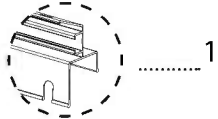
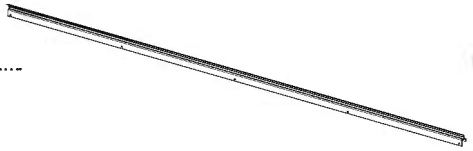

411 ..... 5



..... 5

466 ..... 5



..... 5

8192 ..... 4



..... 4

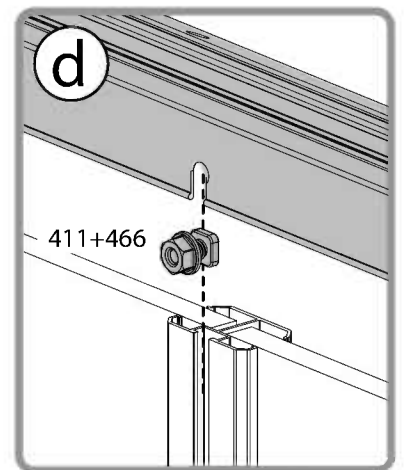
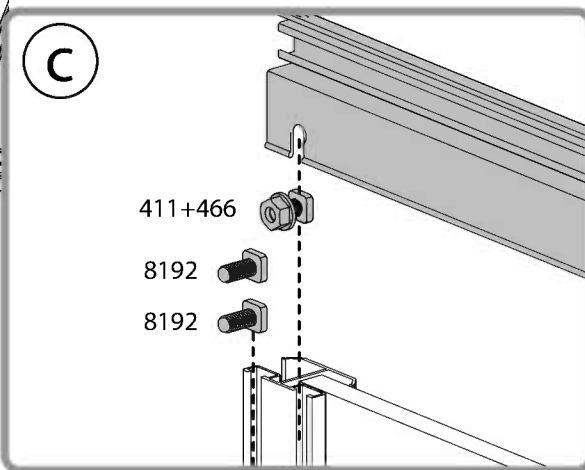
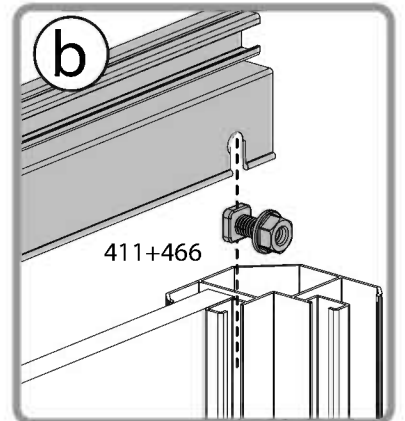
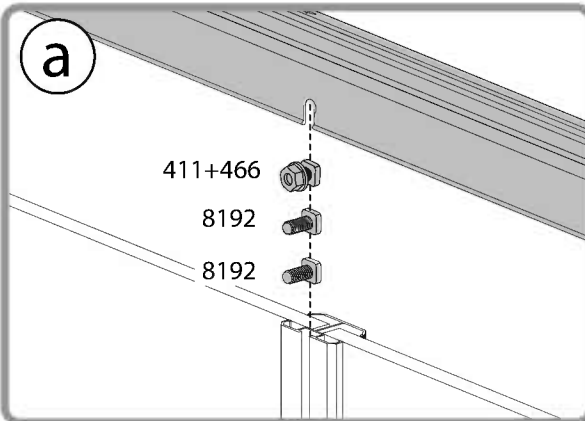
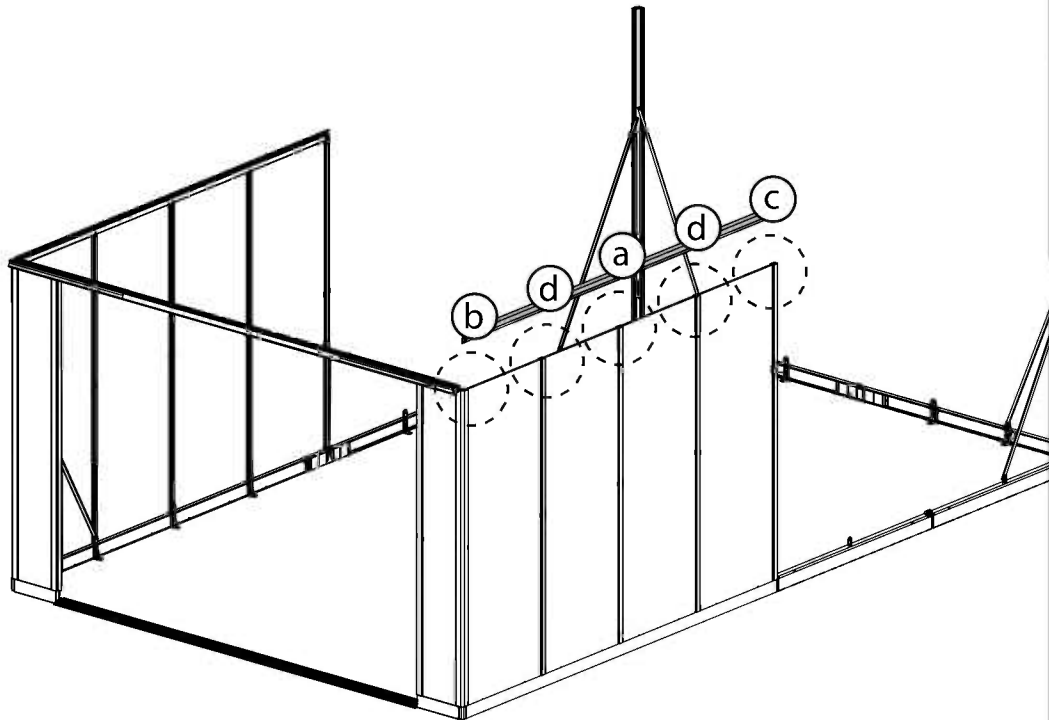
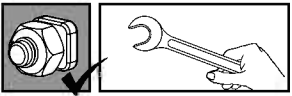

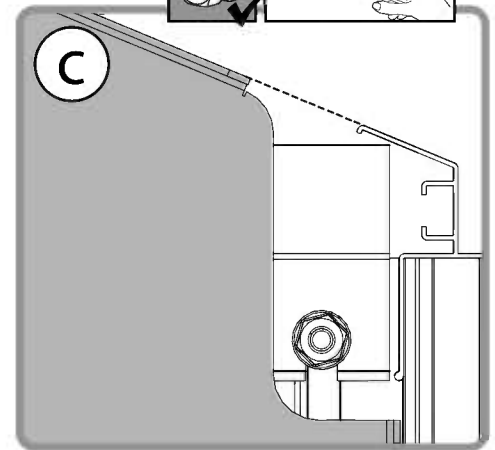
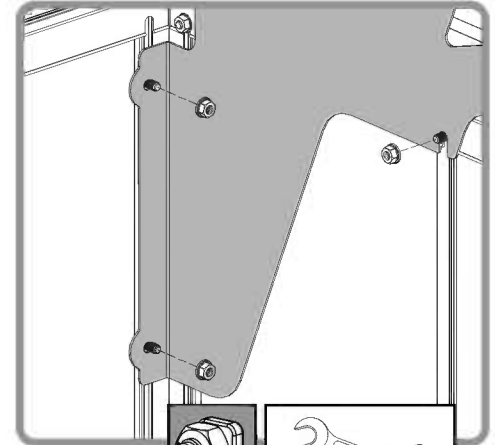
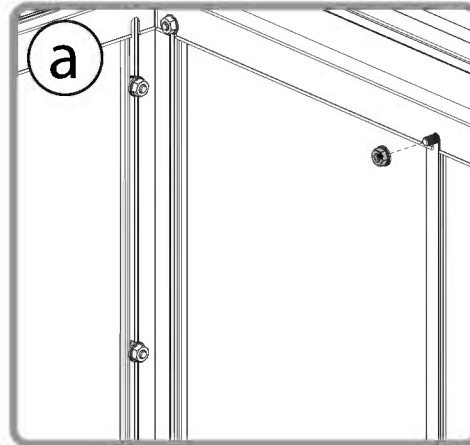
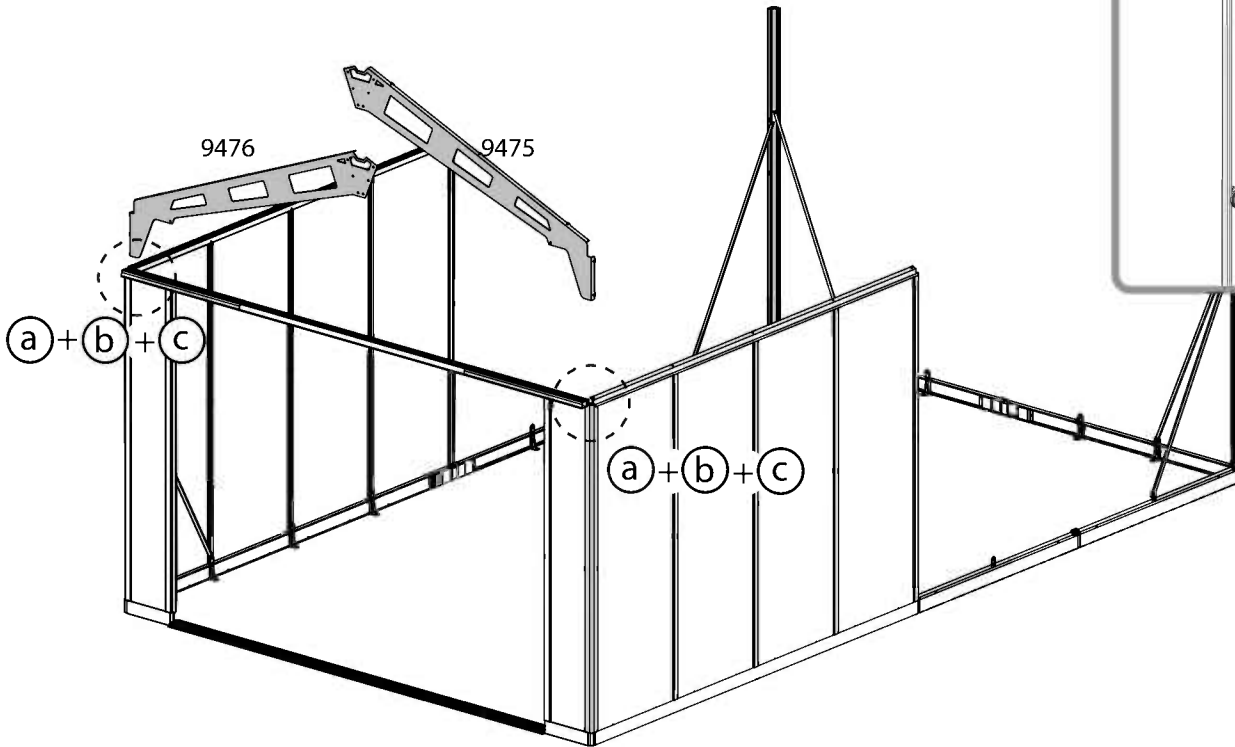
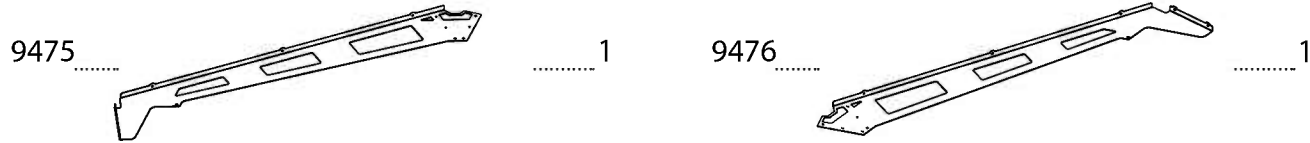
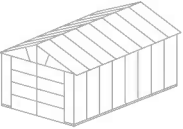

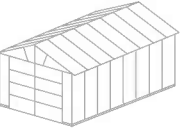

97 ..... 6



466 ..... 12



8192 ..... 6

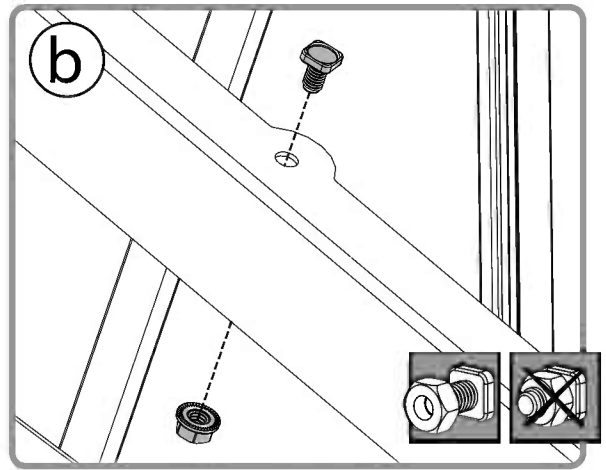
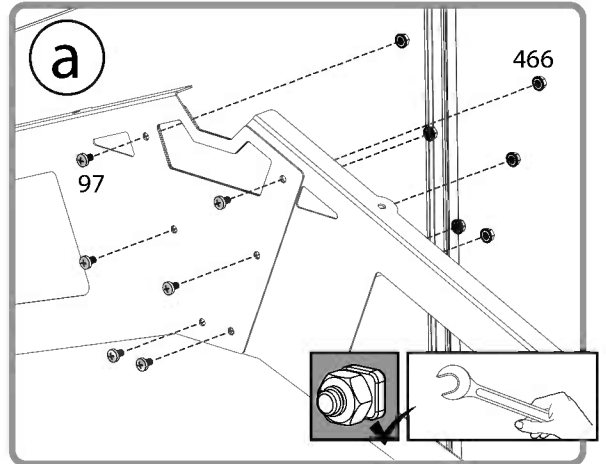
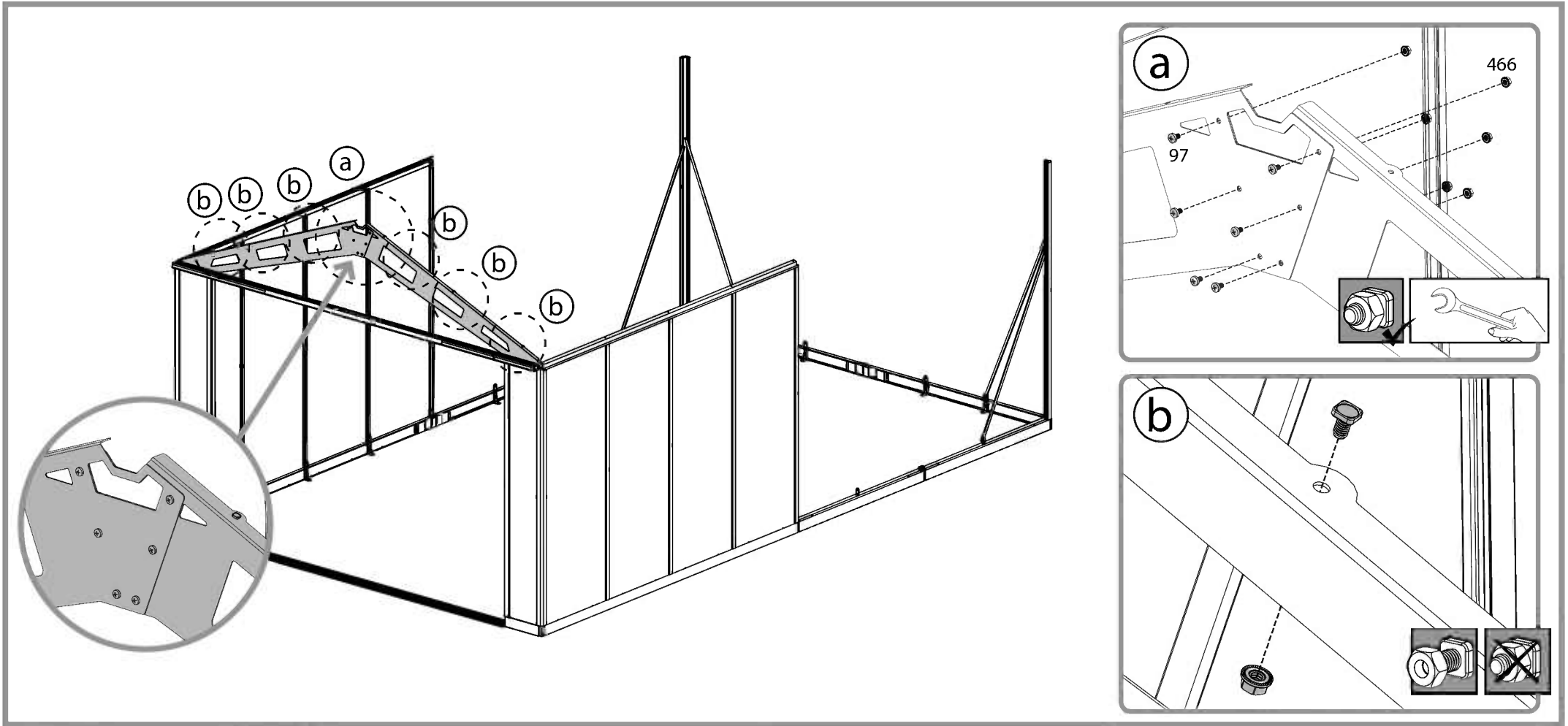
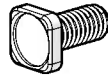



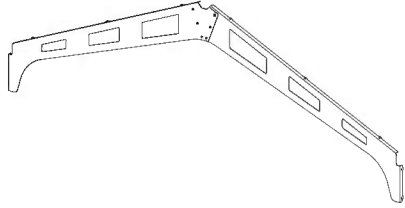
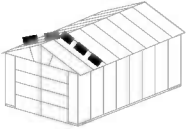

466 .....  ..... 4

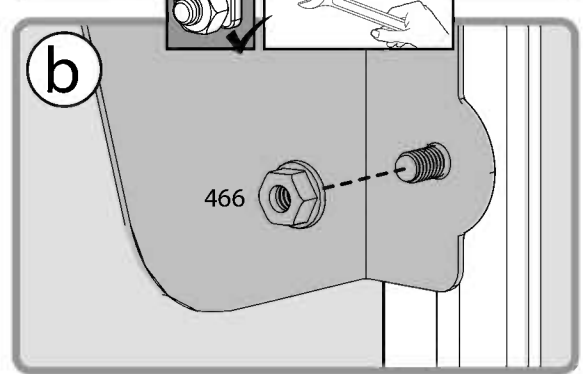
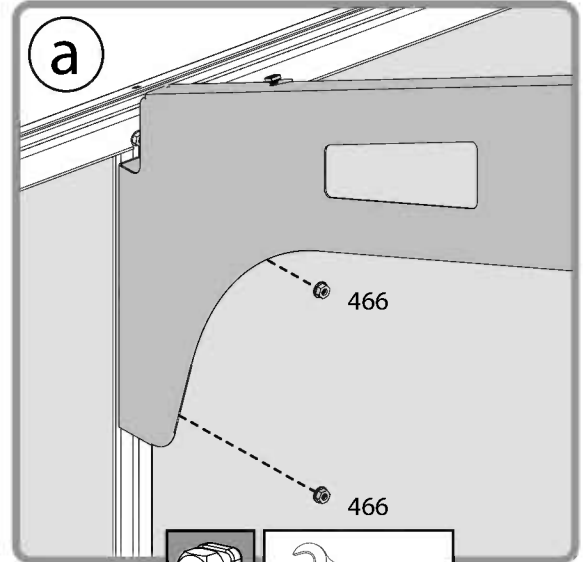
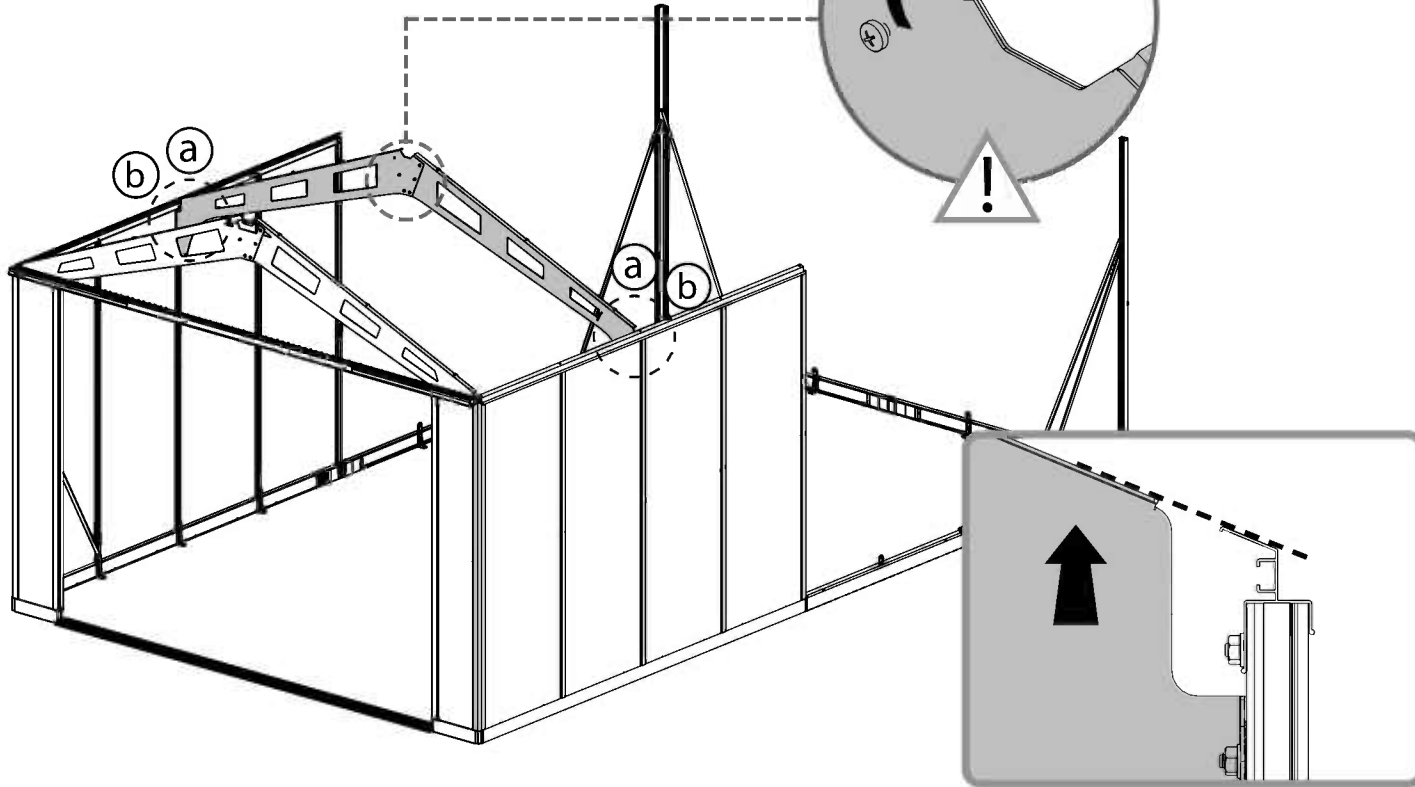
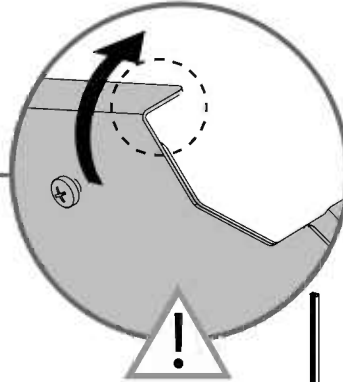
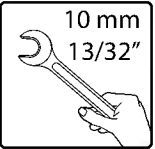
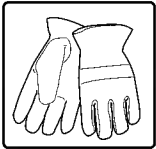
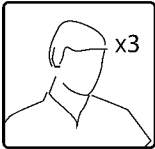

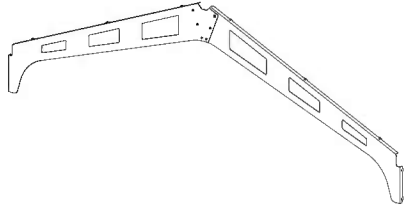

466 .....  ..... 4

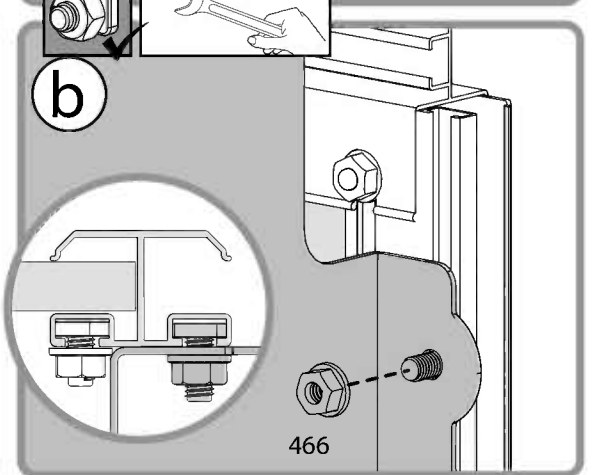
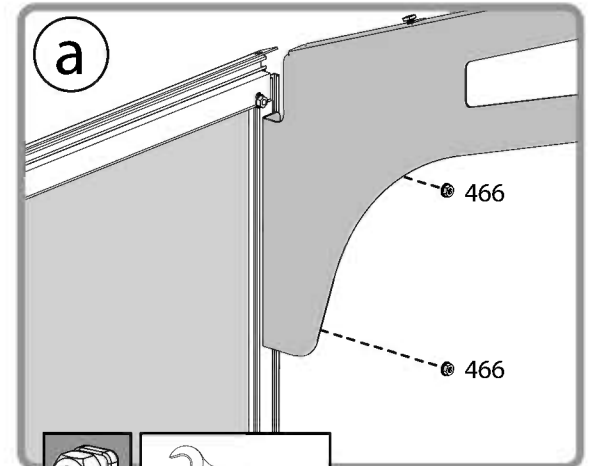
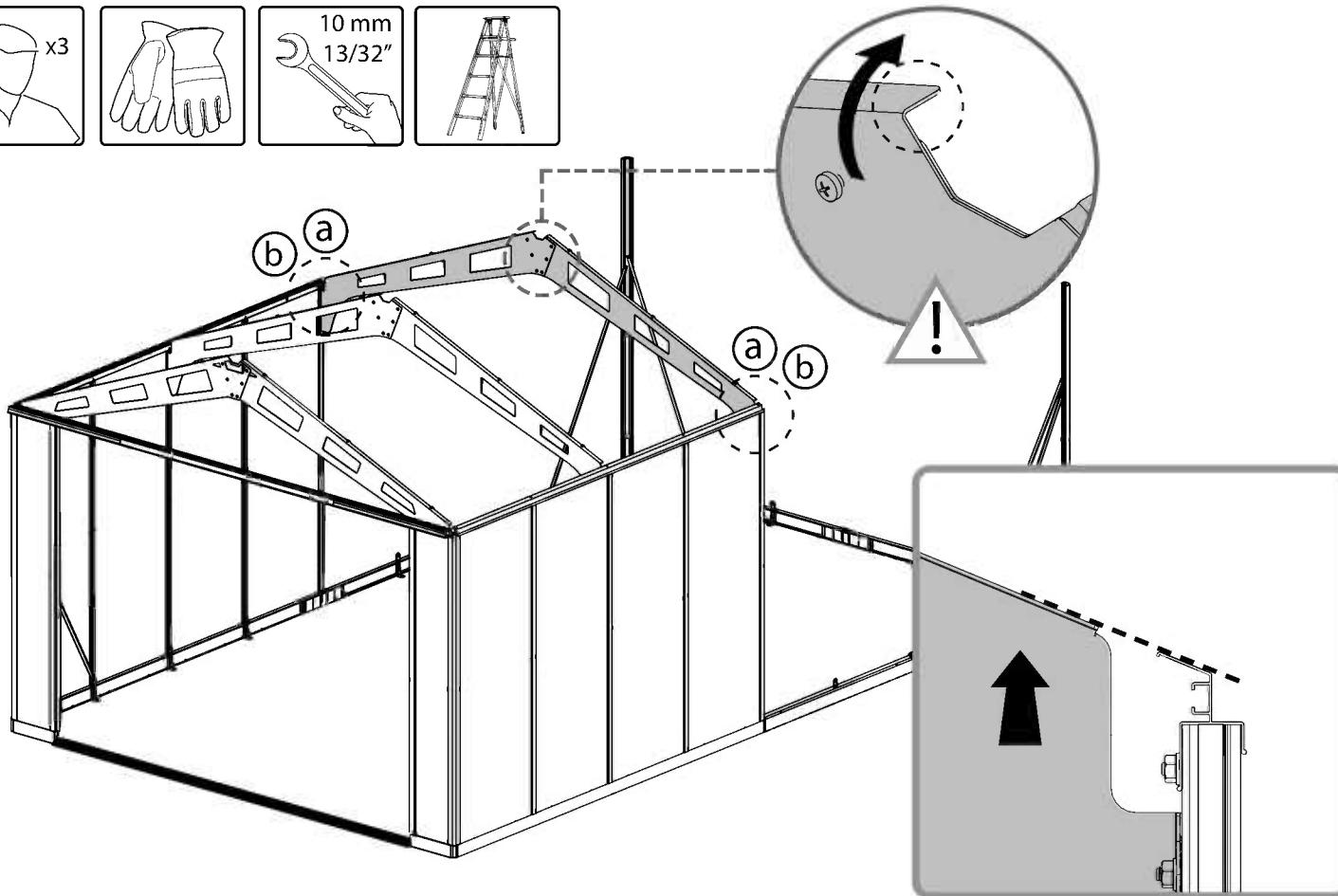
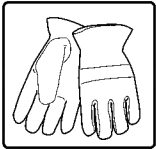
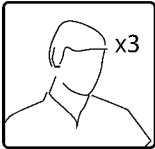

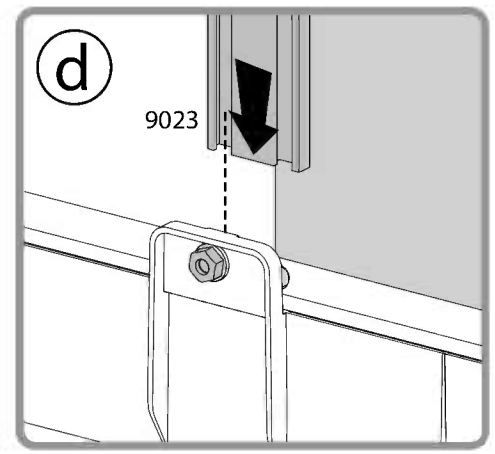
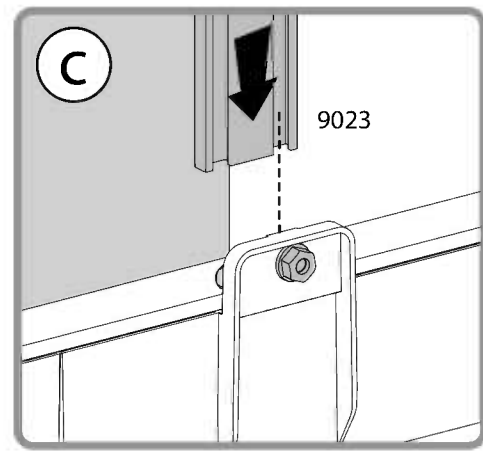
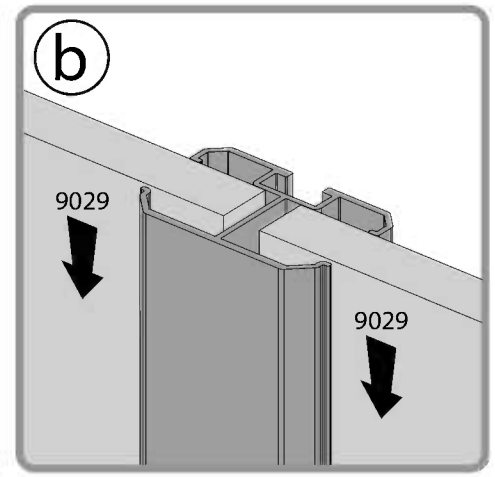
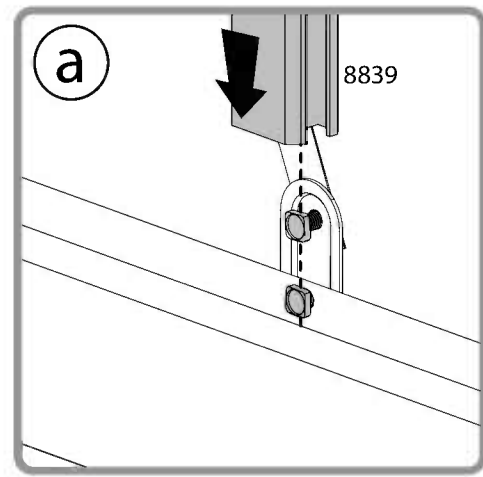
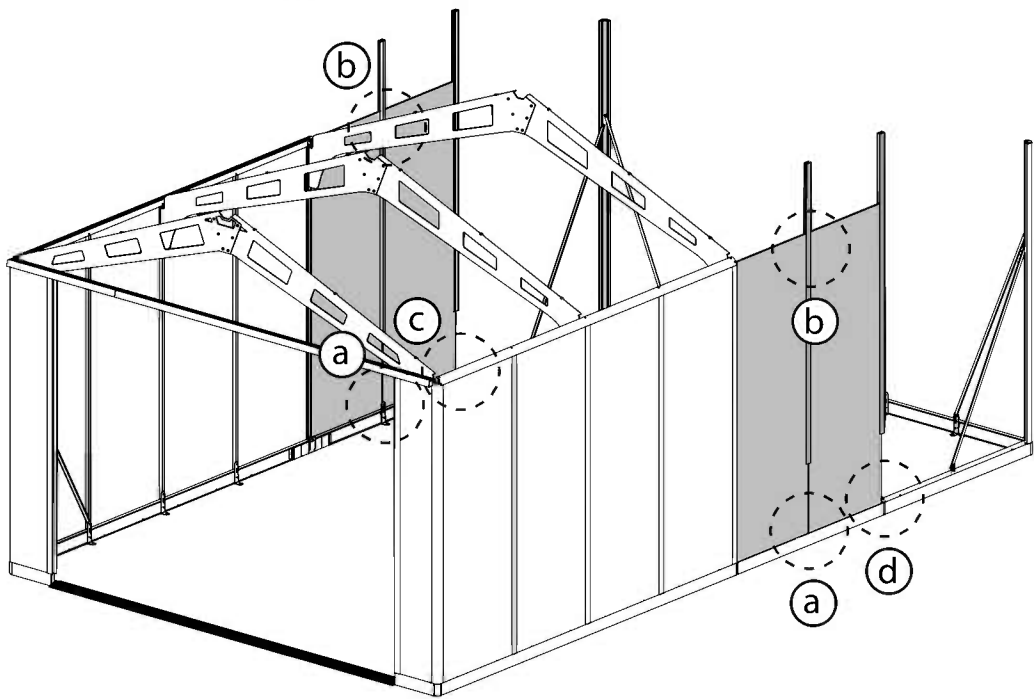
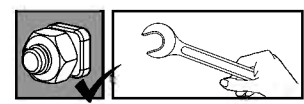
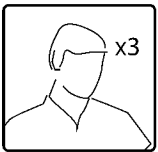
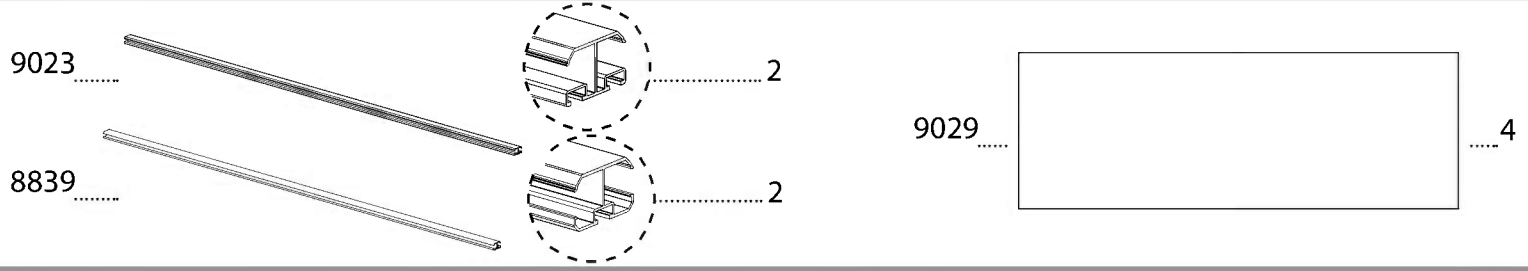
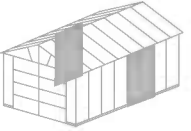

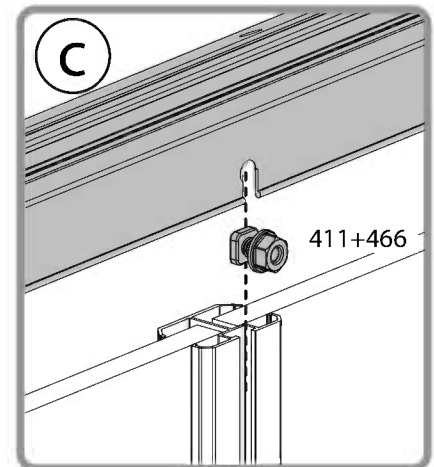
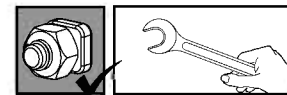
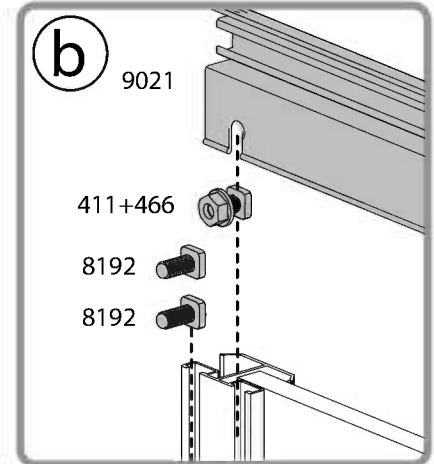
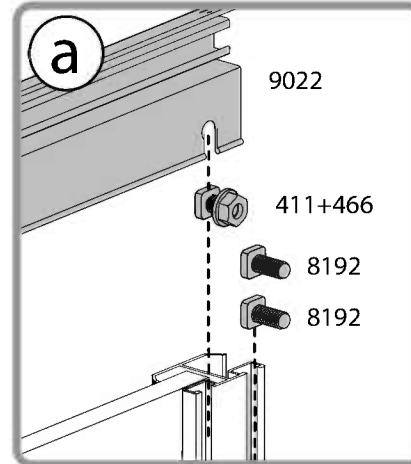
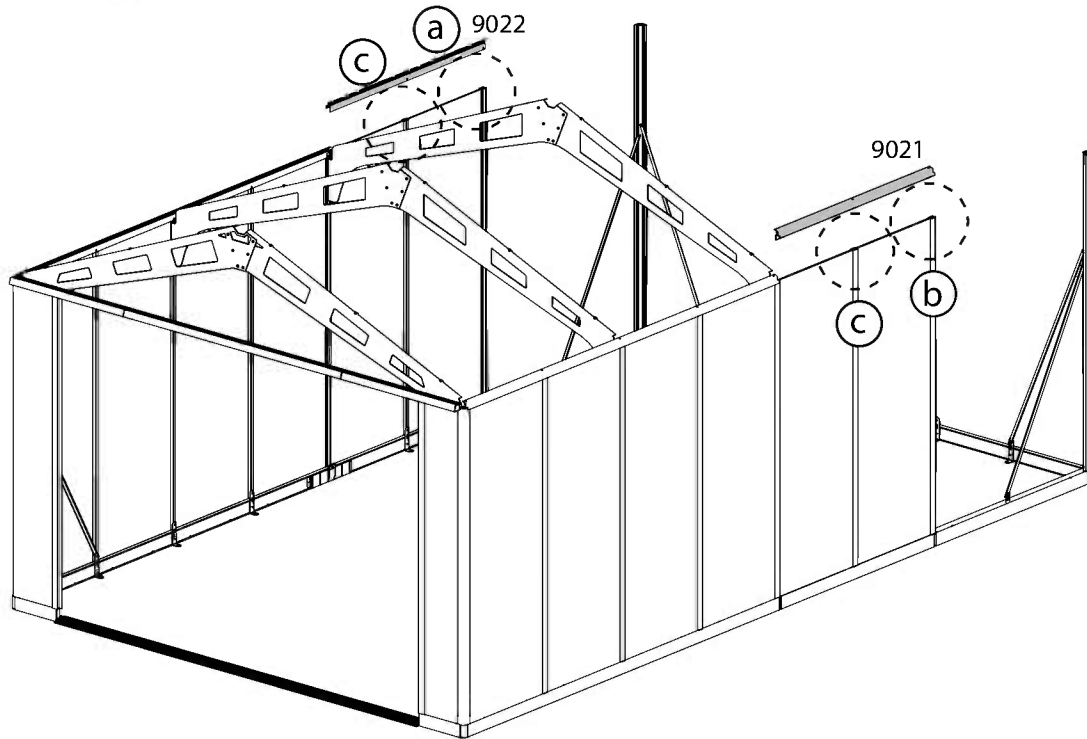
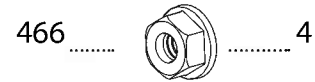
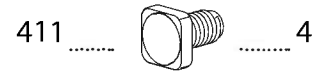
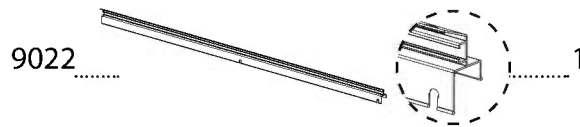
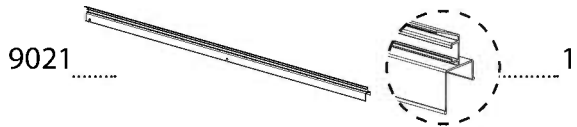



- 7985..... 2      411..... 8      466..... 8

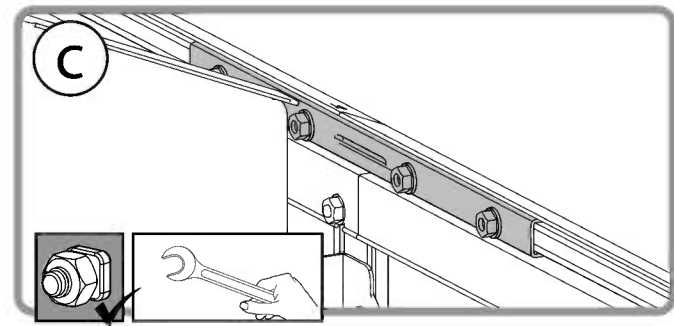
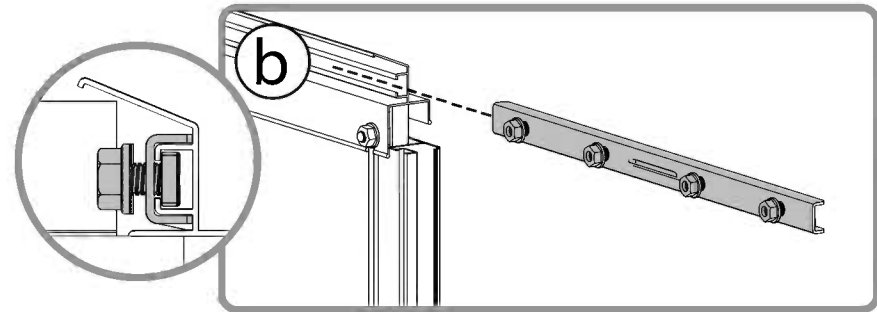
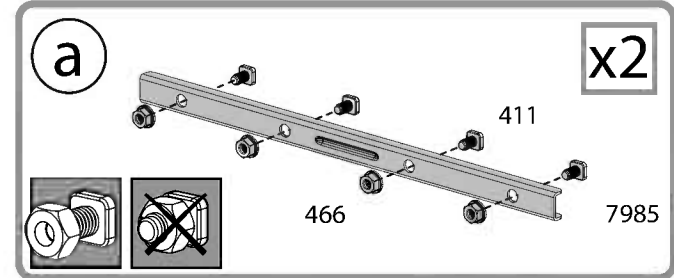
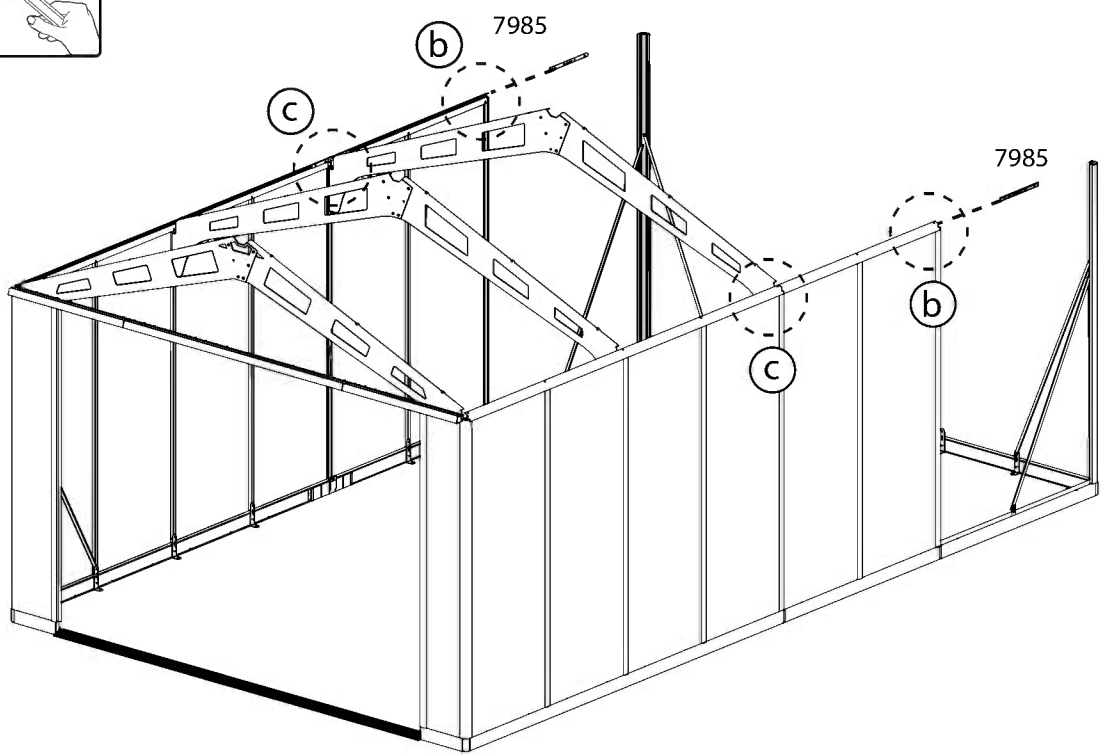

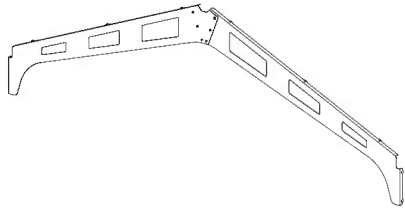

466 .....  ..... 4

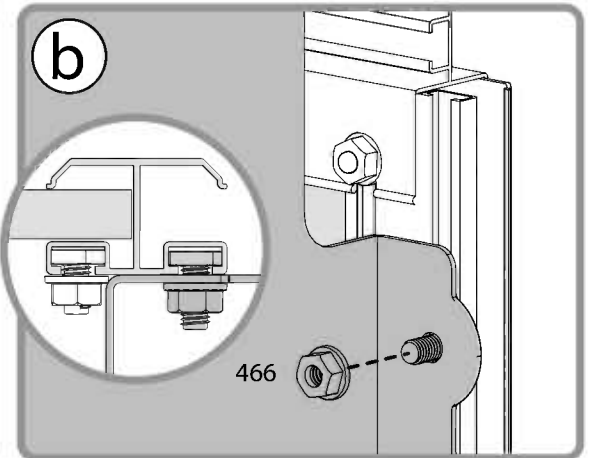
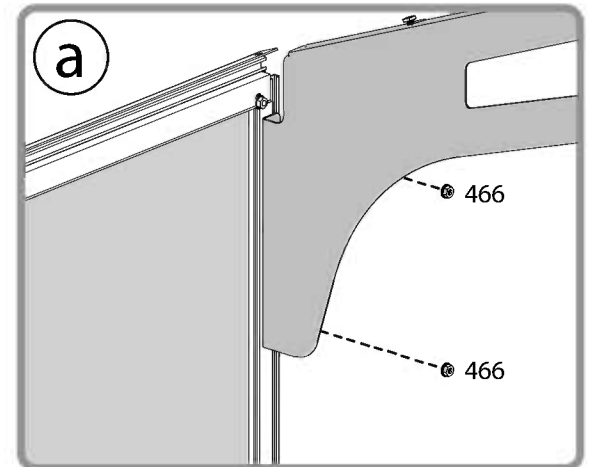
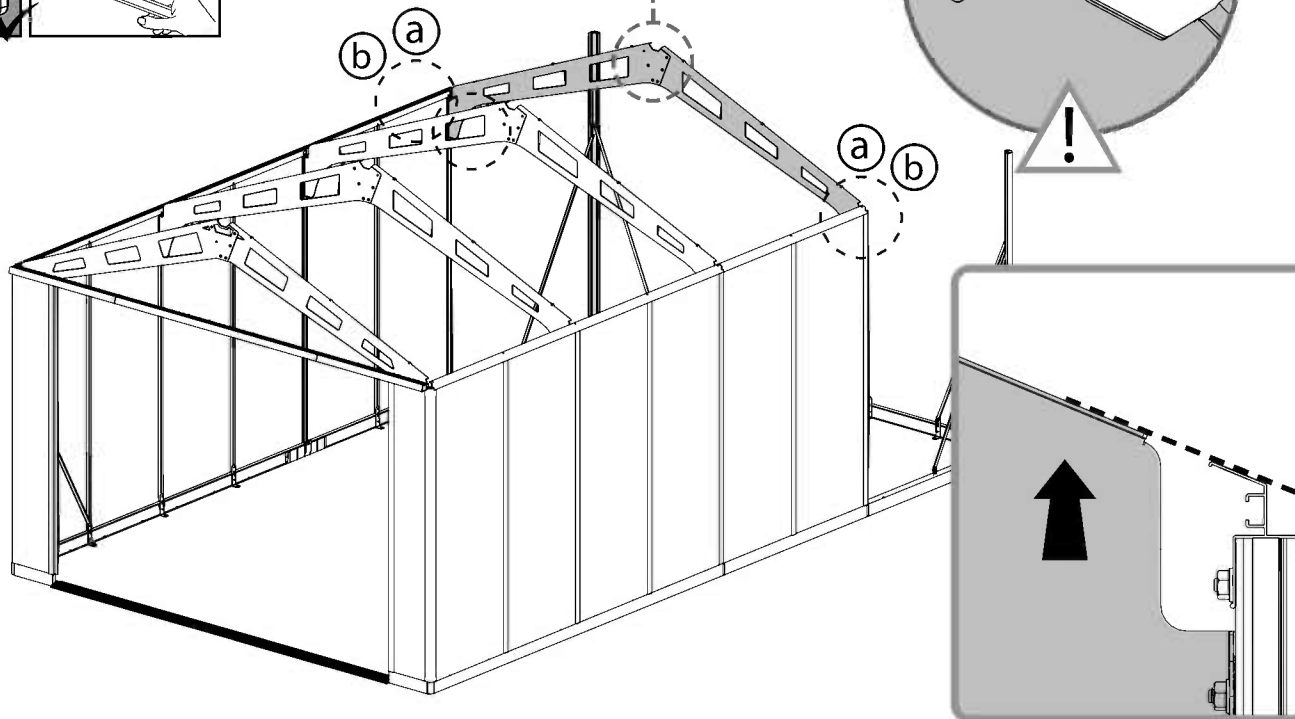
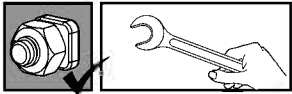
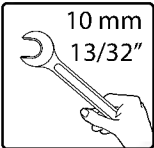
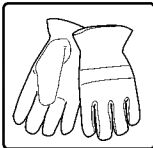
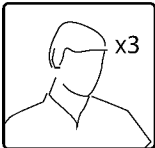

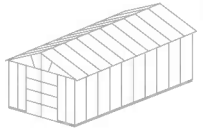
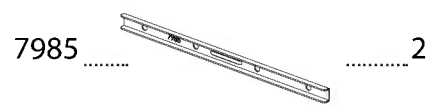
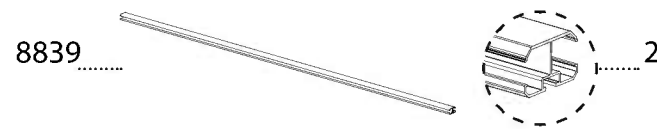
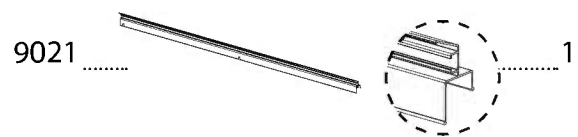
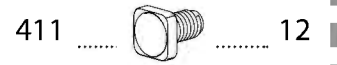
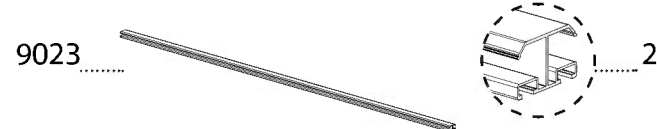
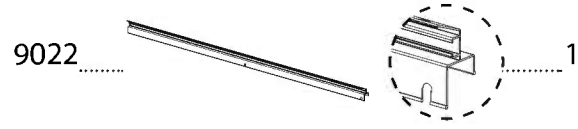
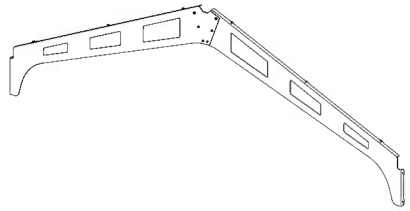

11'x21'

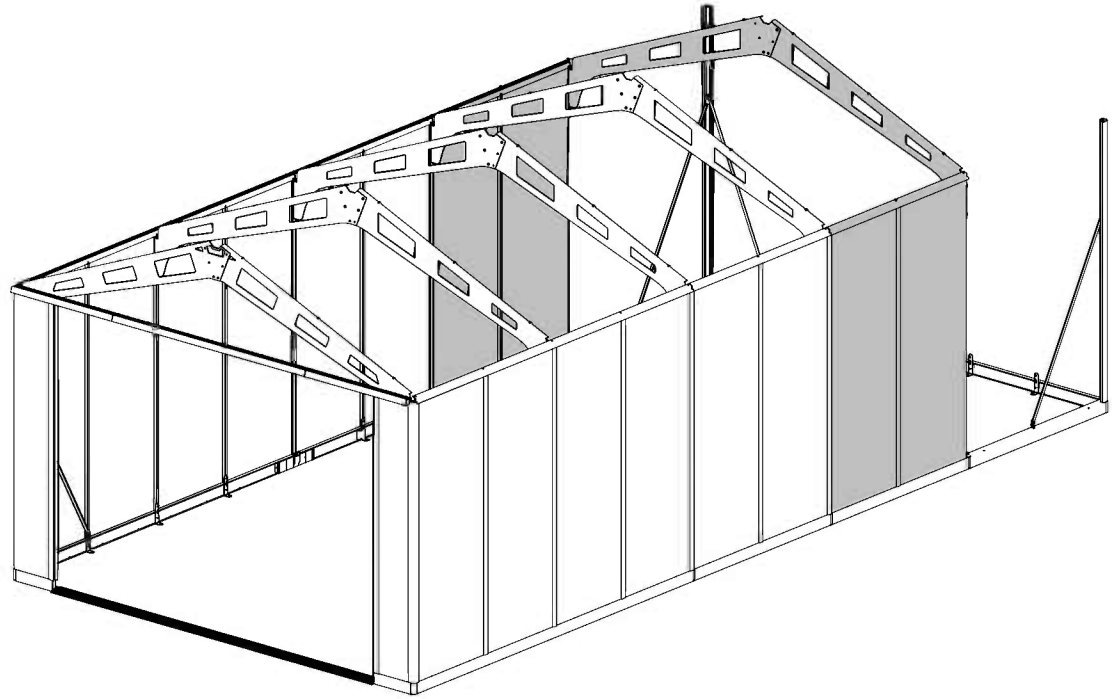

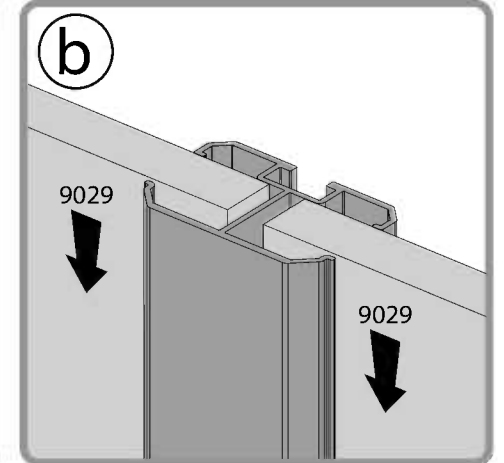
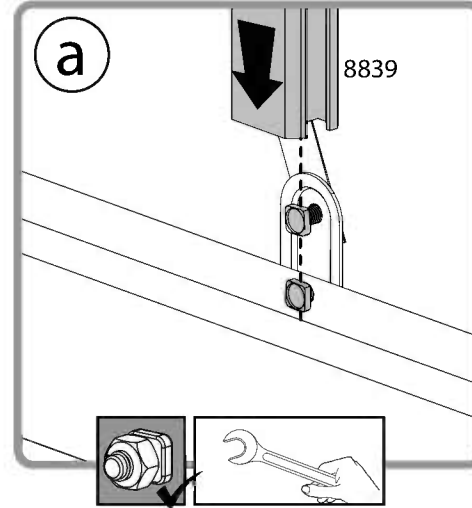
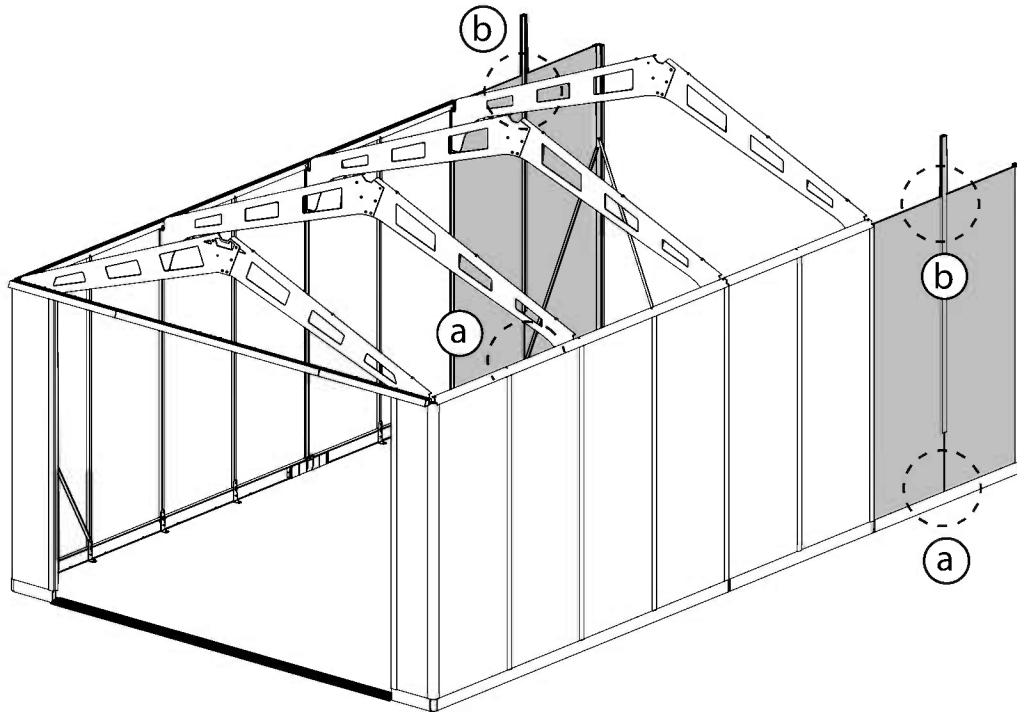
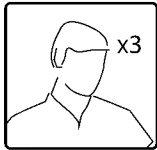
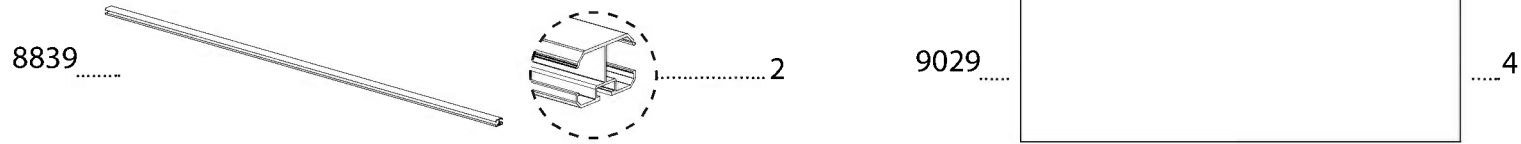
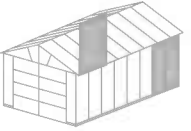



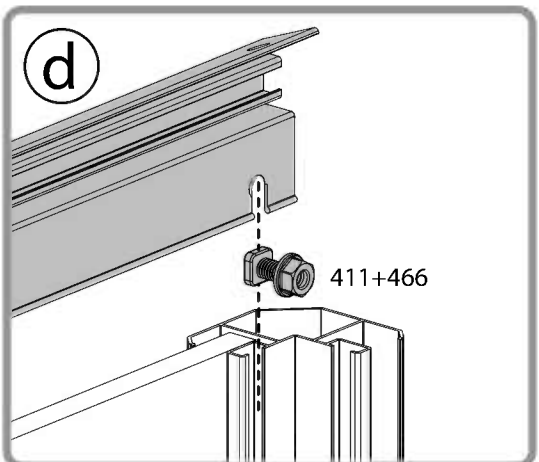
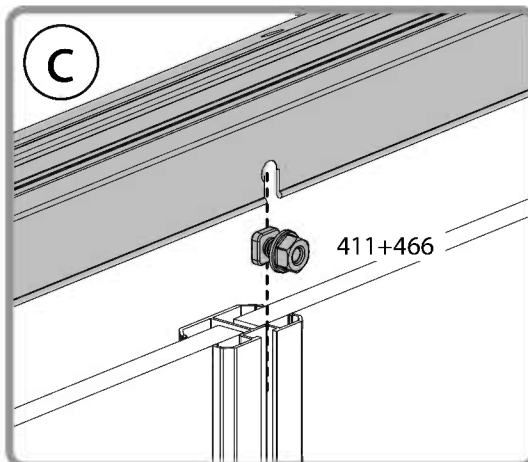
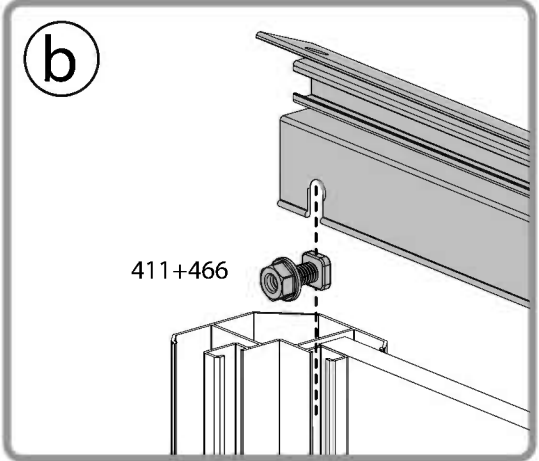
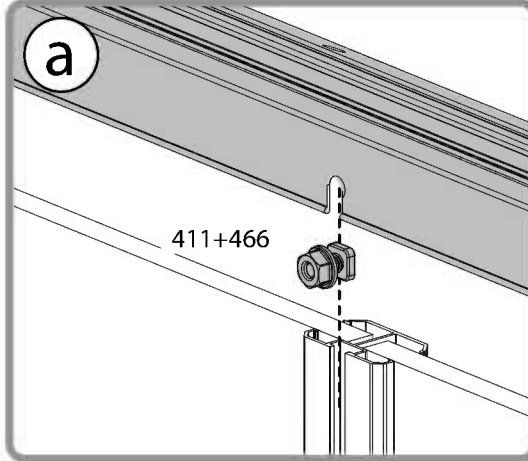
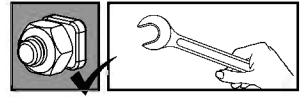
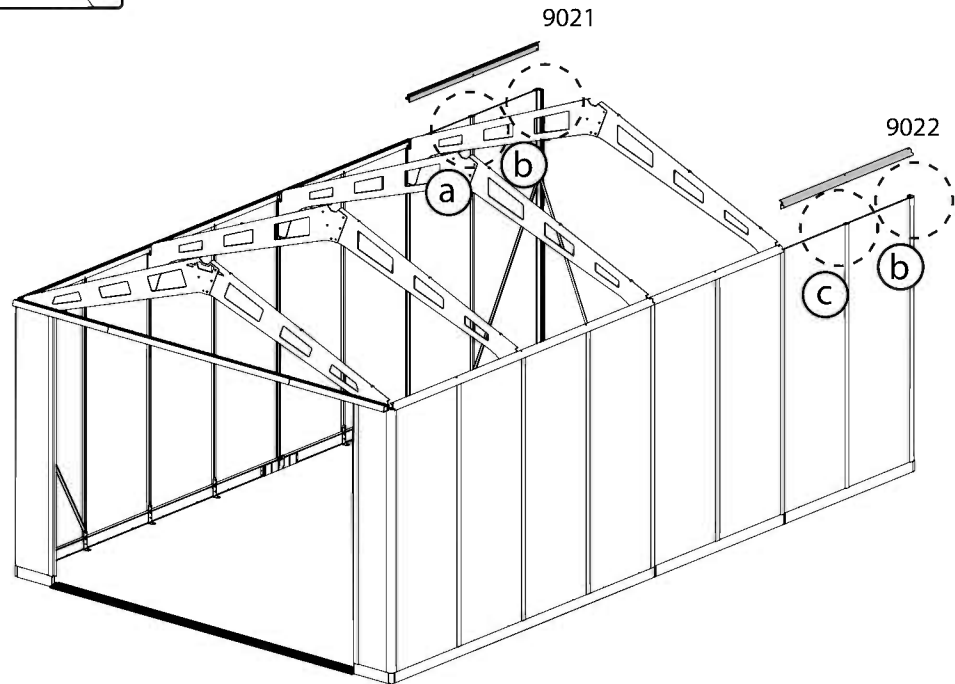
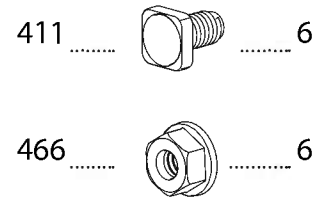
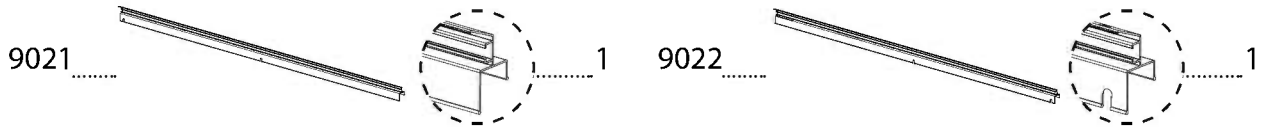

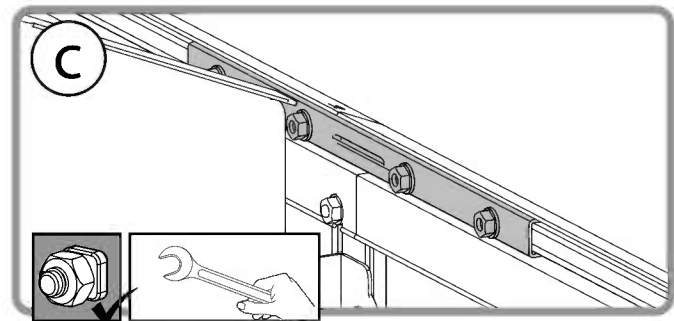
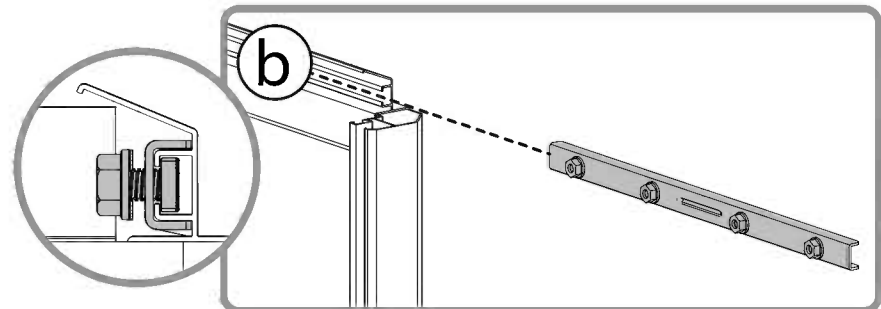
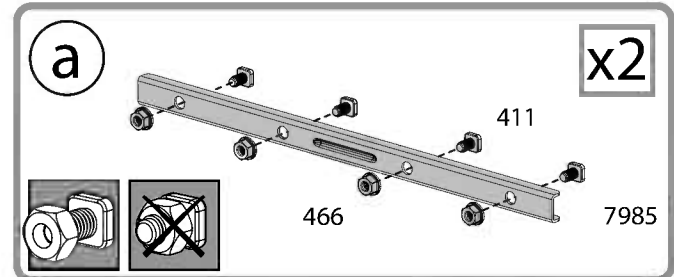
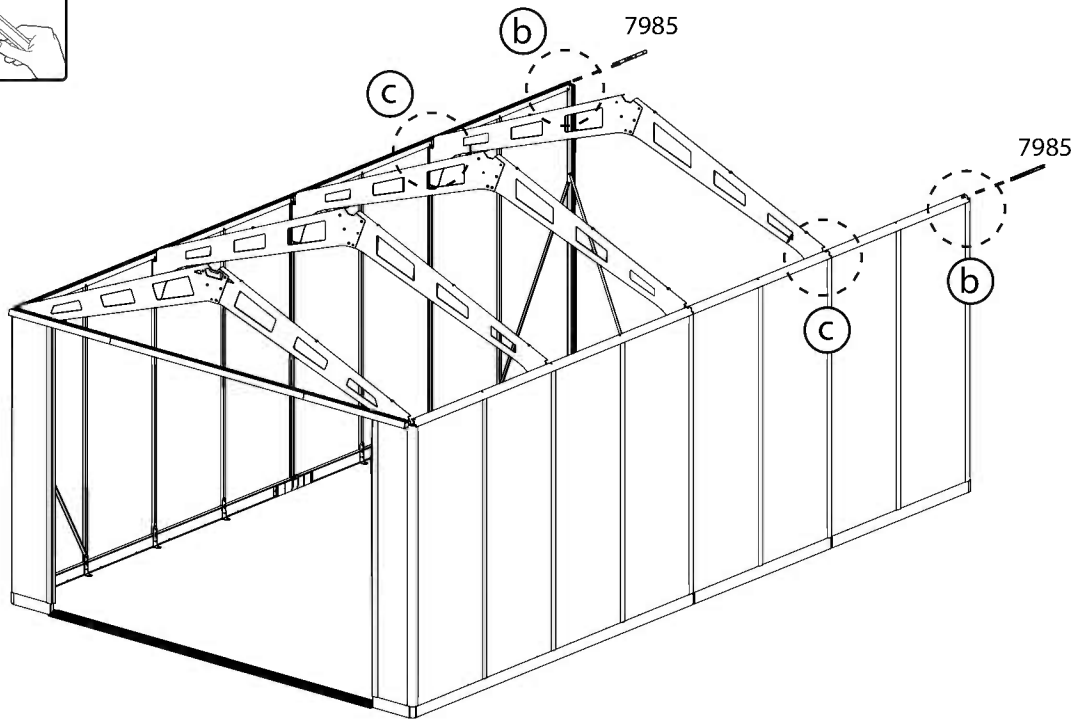
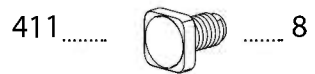
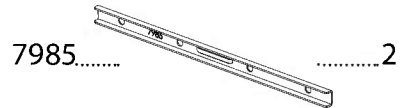





8842 ..... 1

8866 ..... 1

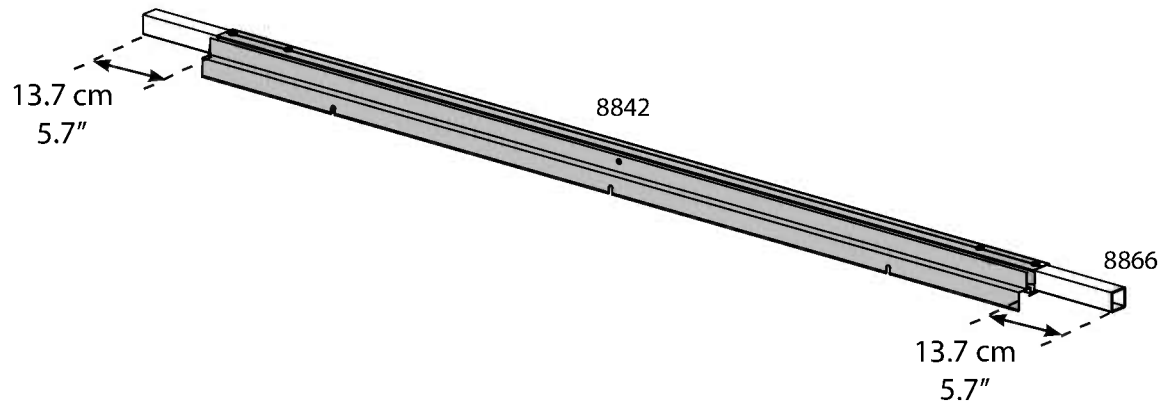
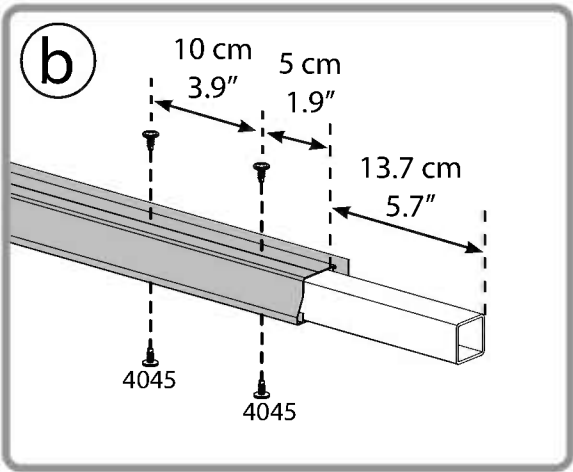
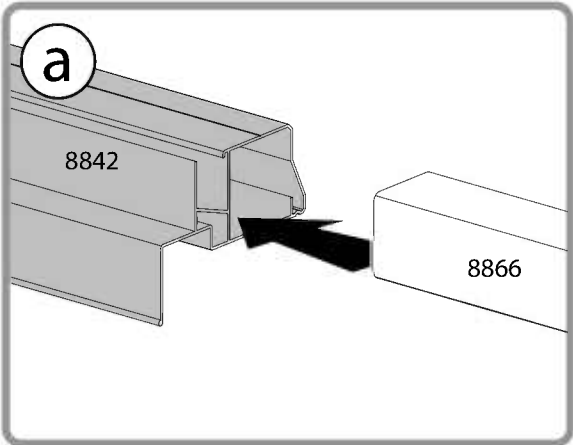
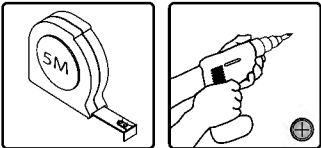
4045 ..... 8



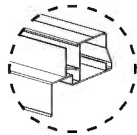

8845 .....   ..... 2

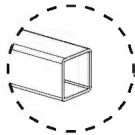
8867 .....   ..... 2

4045 .....  ..... 12

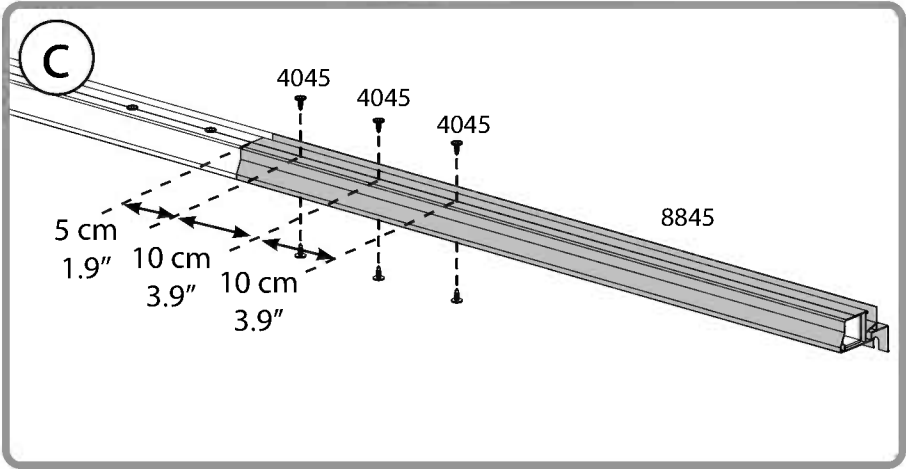
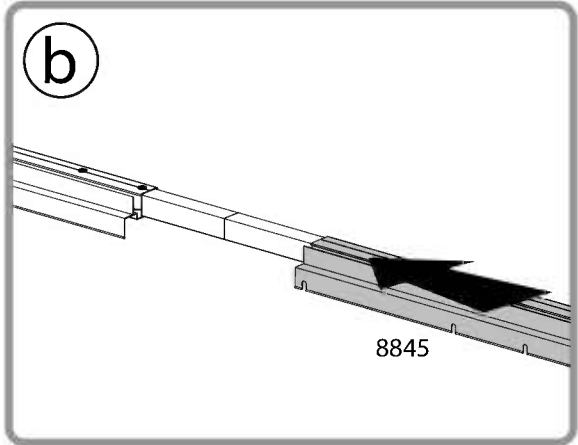
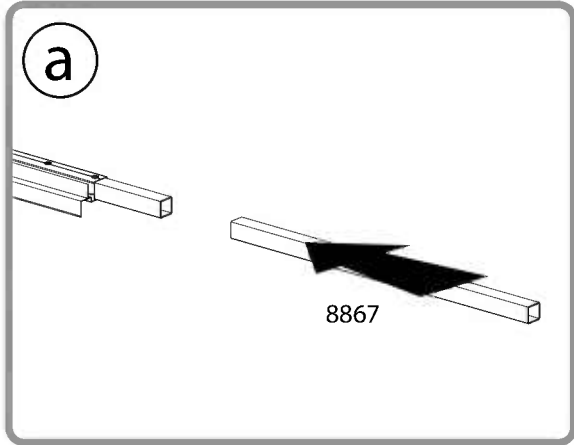
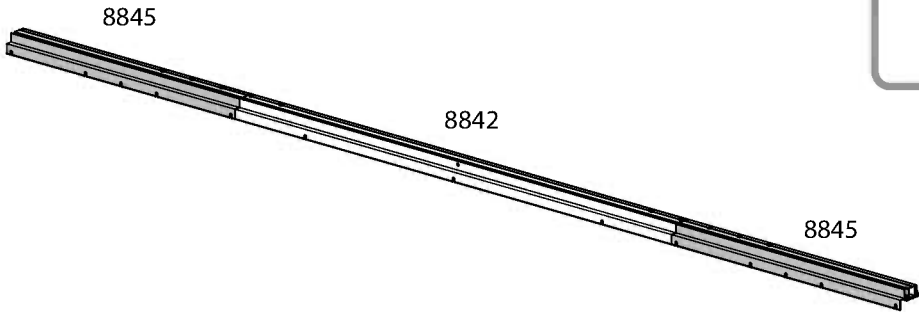
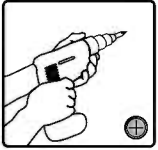



8839.....

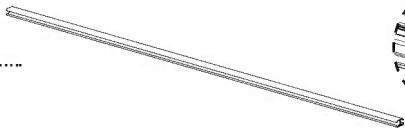

5.....

8858.....





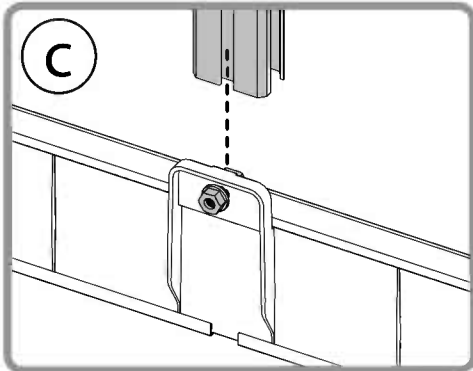
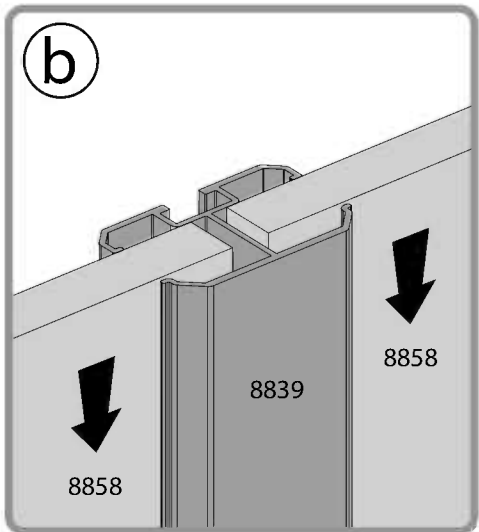
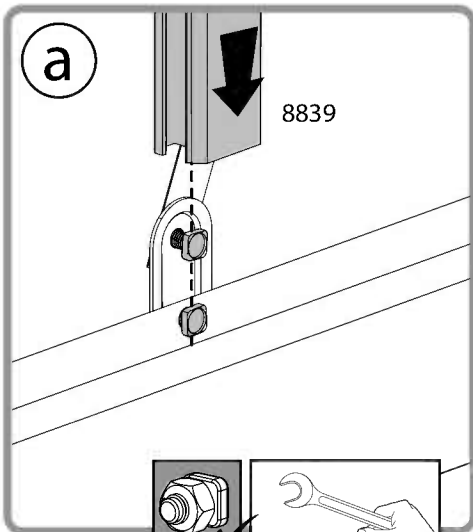
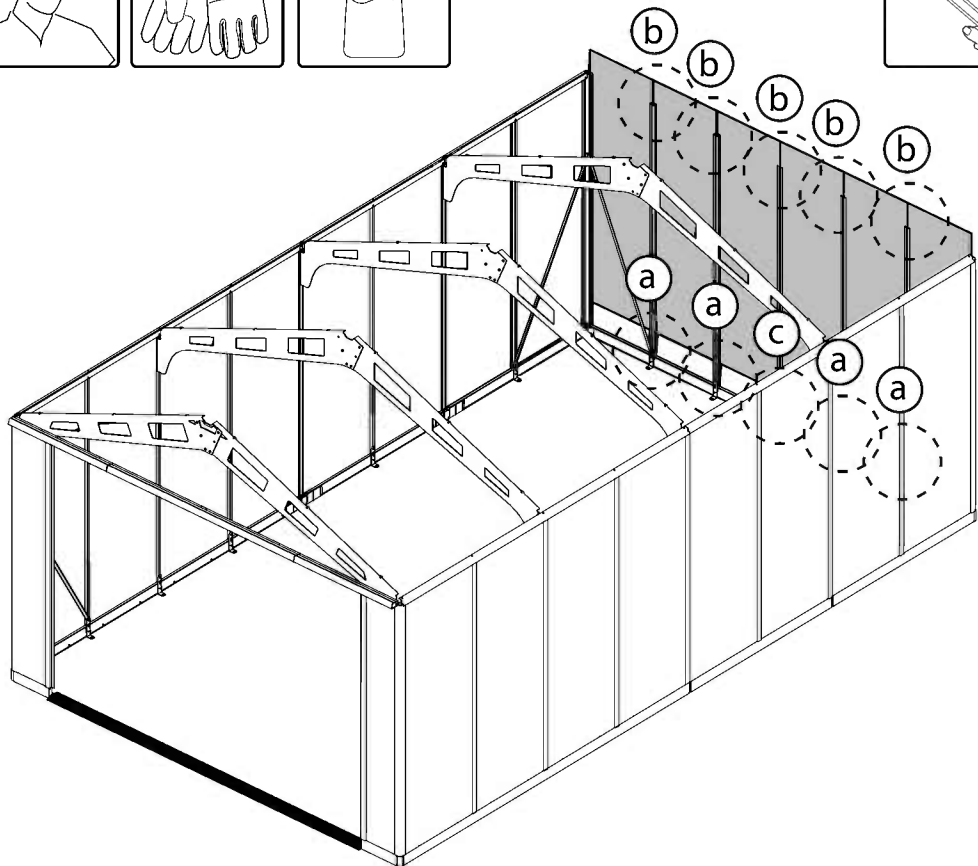
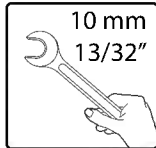
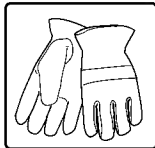
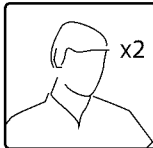

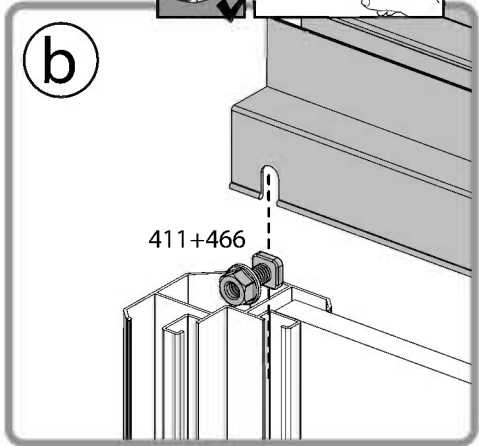
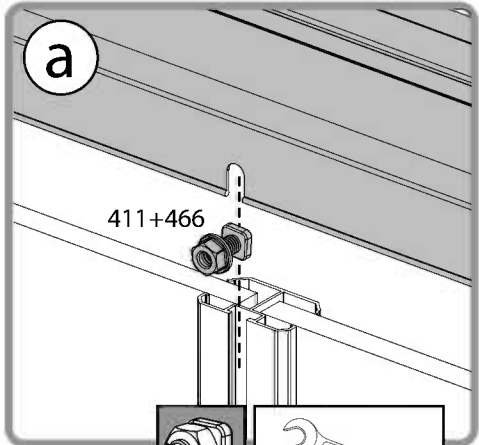
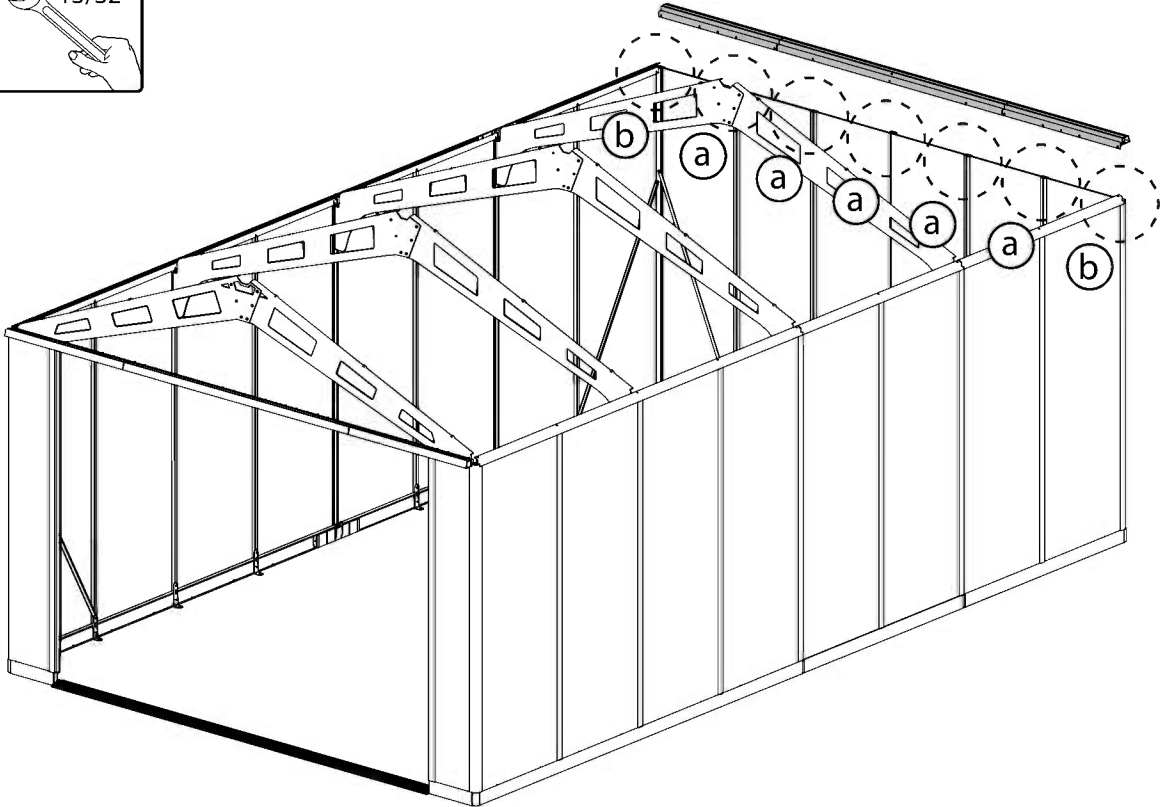
6.....

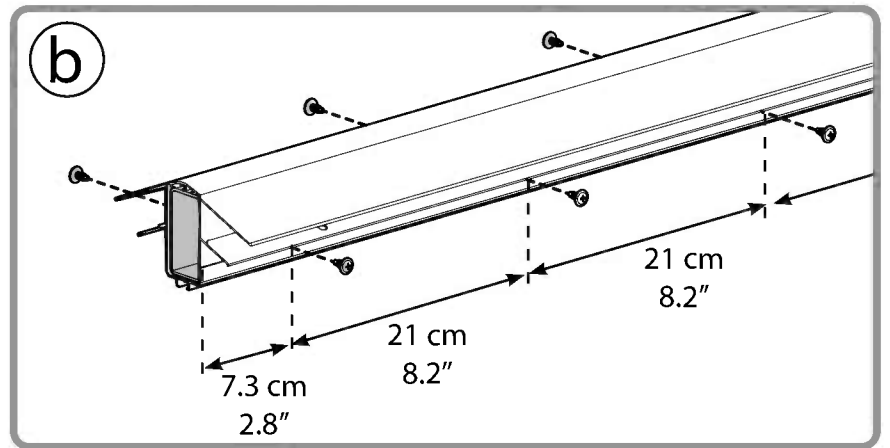
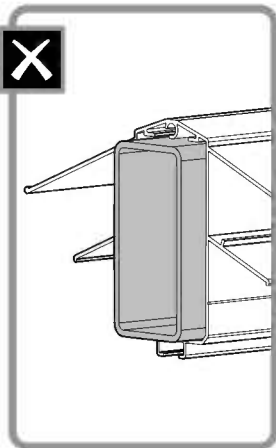
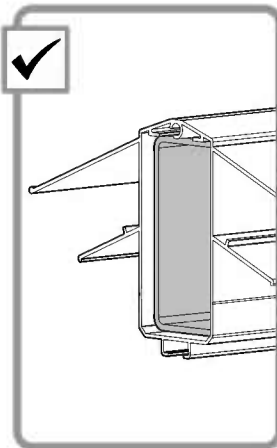
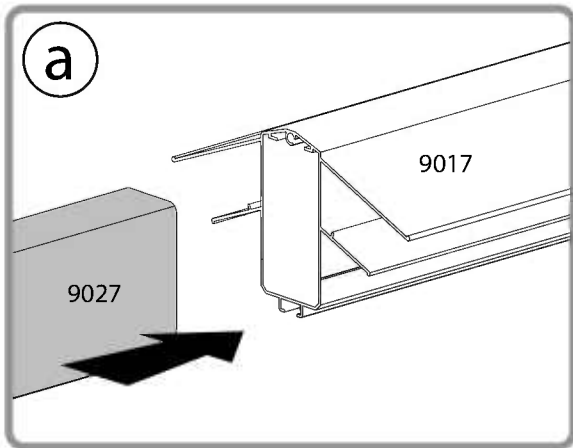
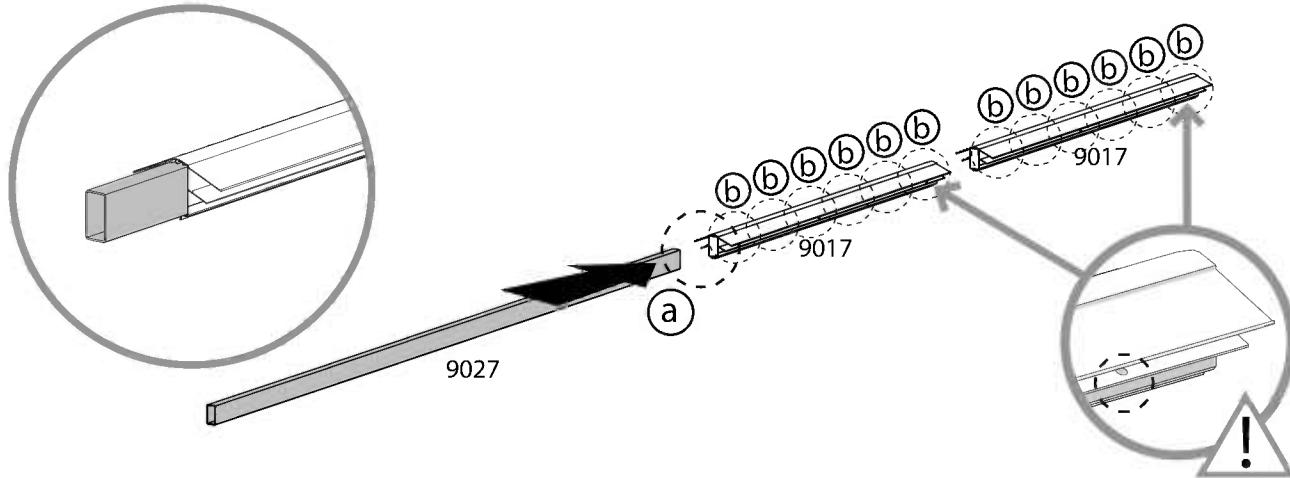
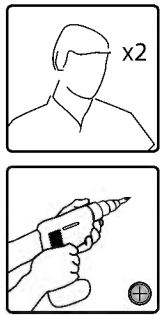
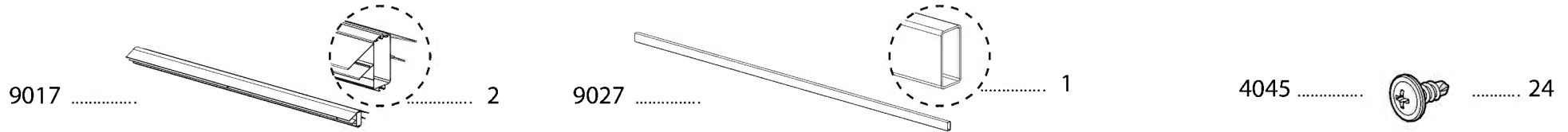



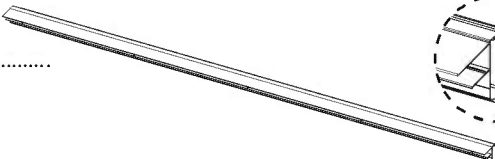



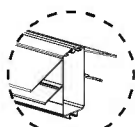
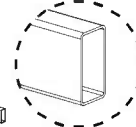

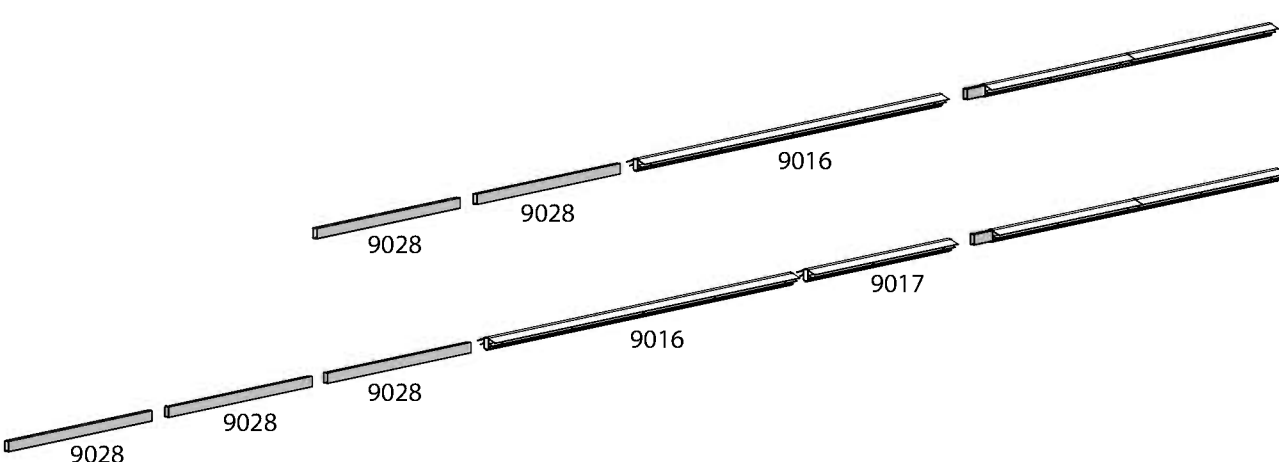
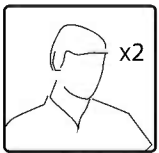
9016 .....		1	4045 .....		26	 11'x21' 9016..... 1 9017..... 1 9028..... 3 4045..... 38
9028 .....		2				
						
						

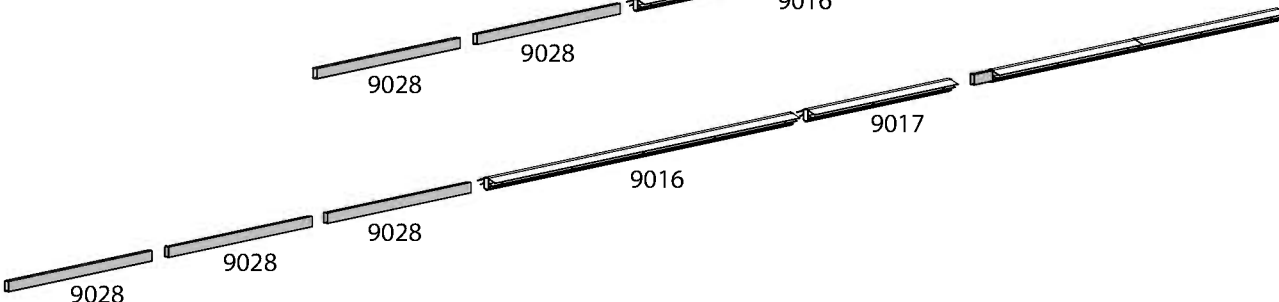
	<p><b>11'x17'</b> 11'x9' + 2 Extension kits</p>	 x2  
	<p><b>11'x21'</b> 11'x9' + 3 Extension kits</p>	

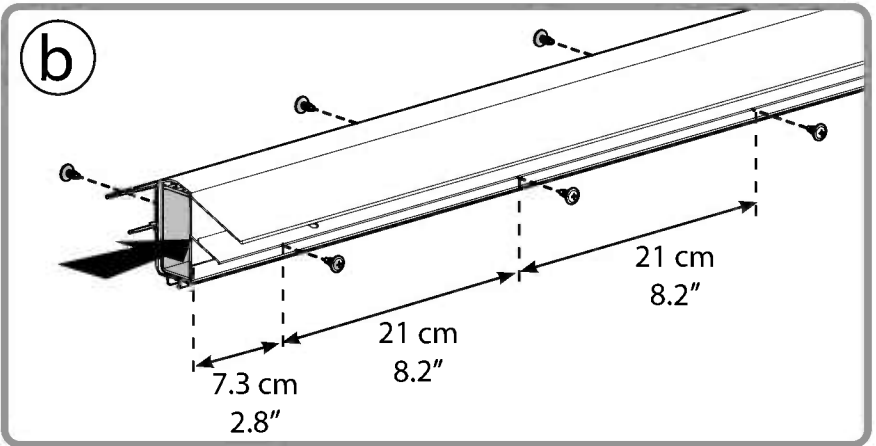
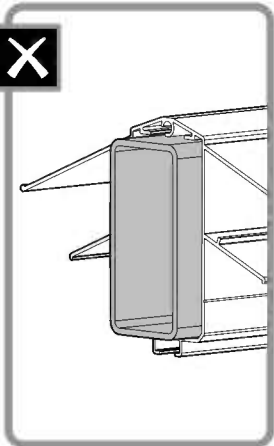
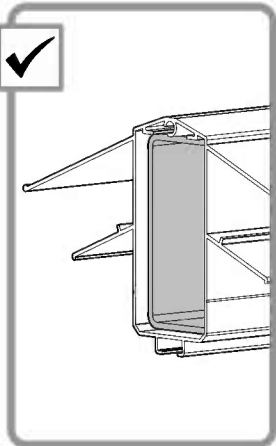
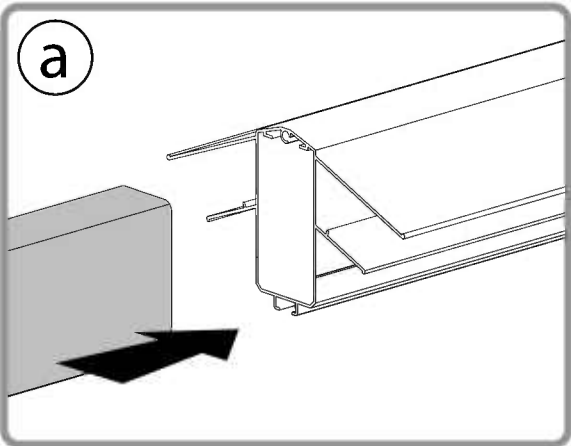





411 ..... 18



466 ..... 18



	411 ..... 22
	466 ..... 22

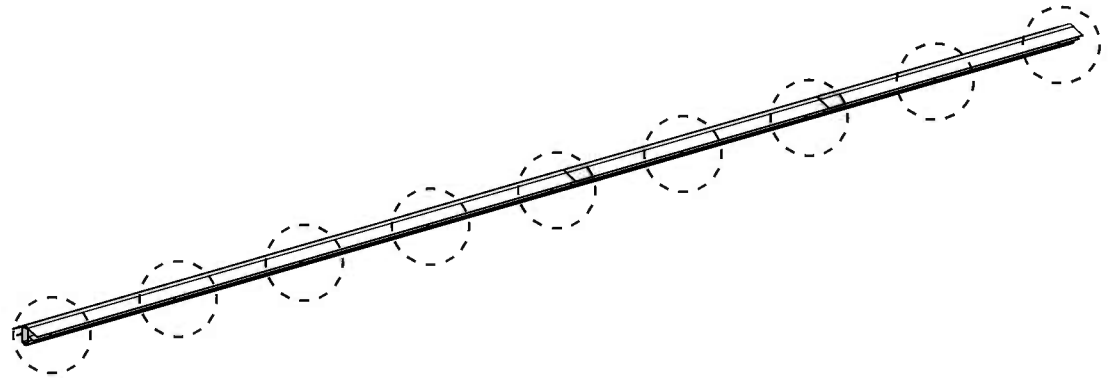
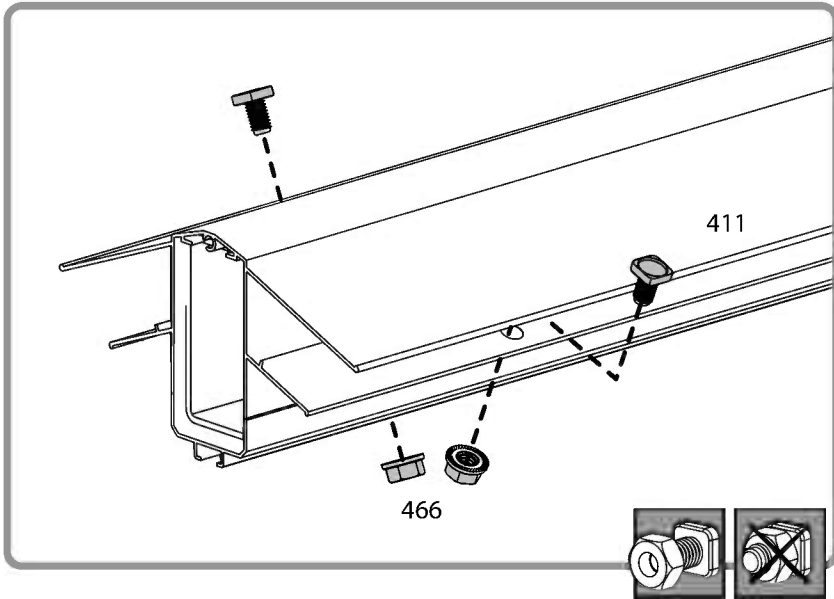



7985 ..... 2

411 ..... 8

466 ..... 8



7985 ..... 3  
 411 ..... 12  
 466 ..... 12

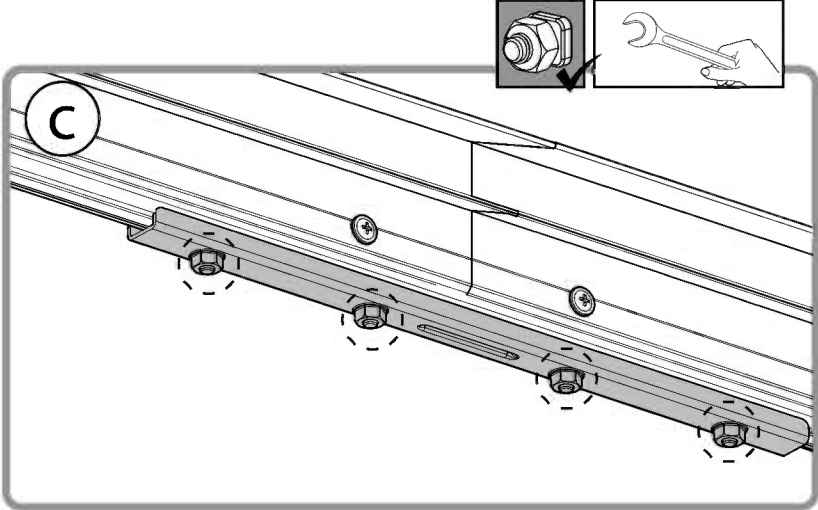
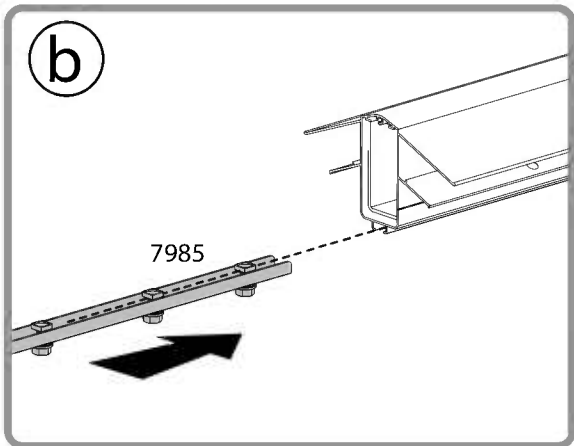
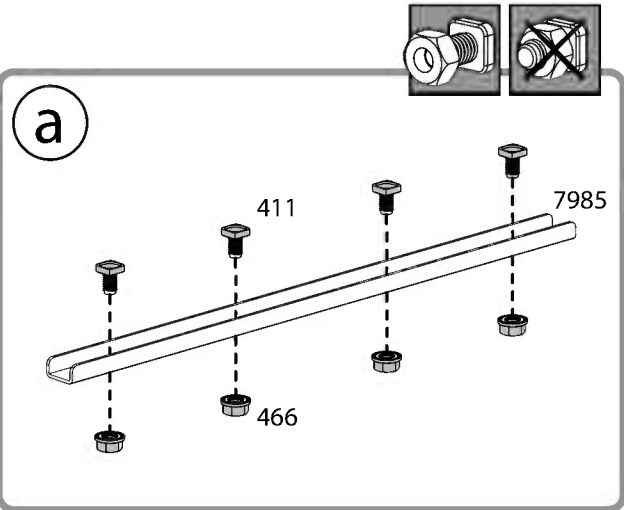
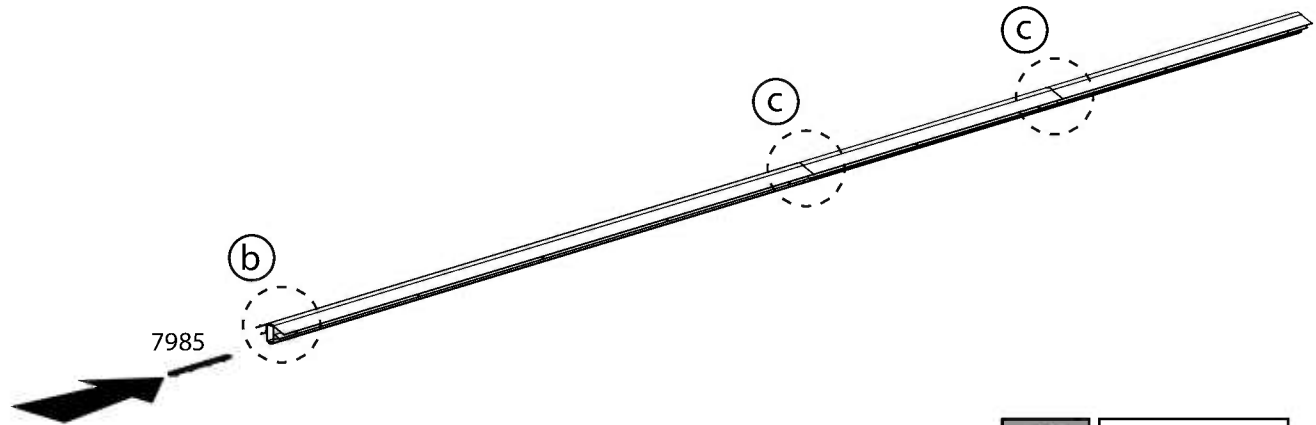



100..... 4



100 ..... 6

11'x21'

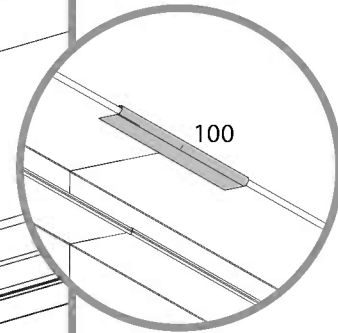
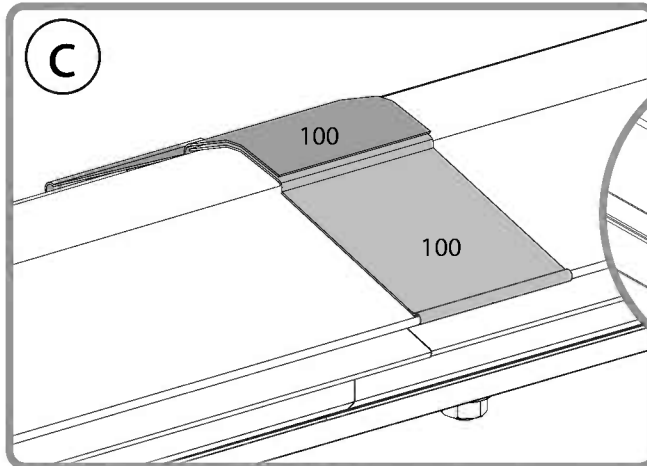
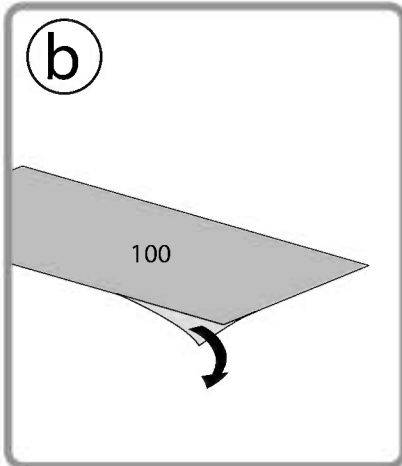
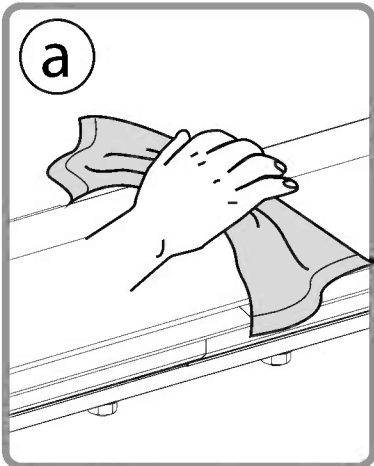
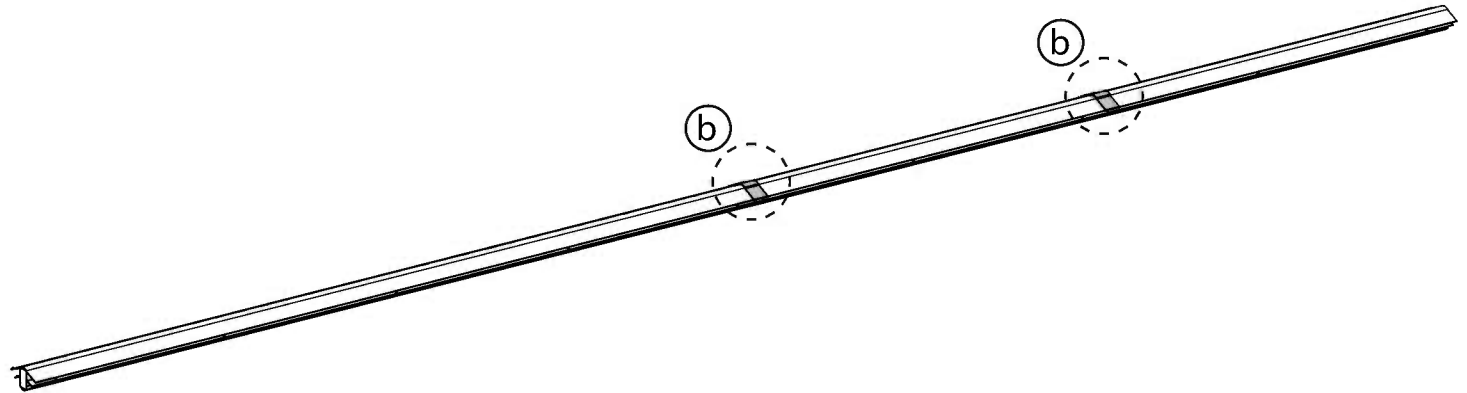

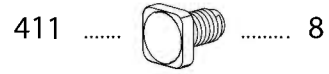
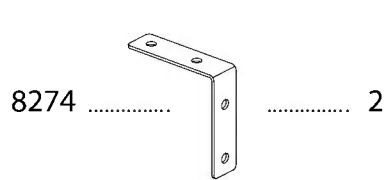

a

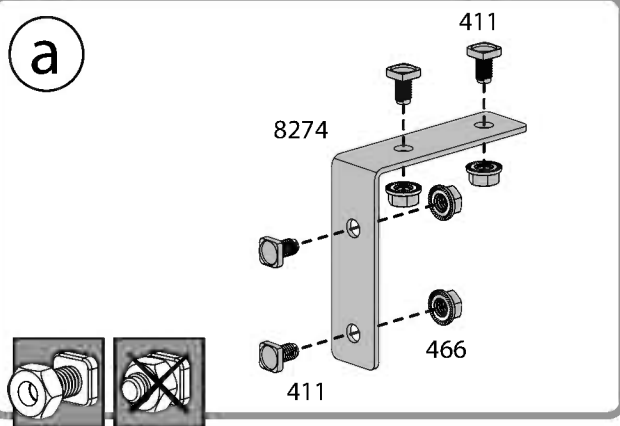

b

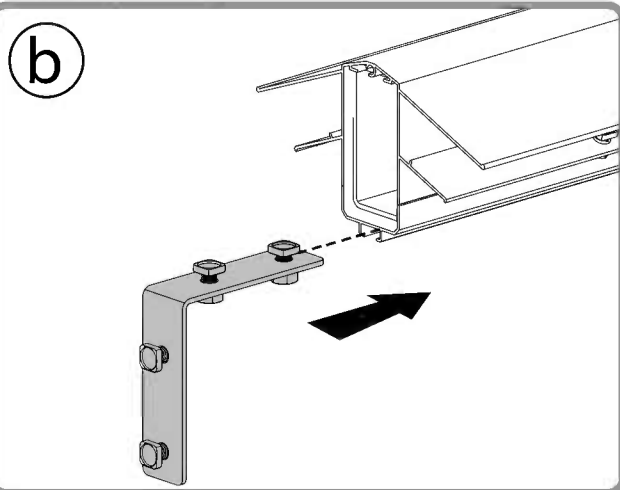

c

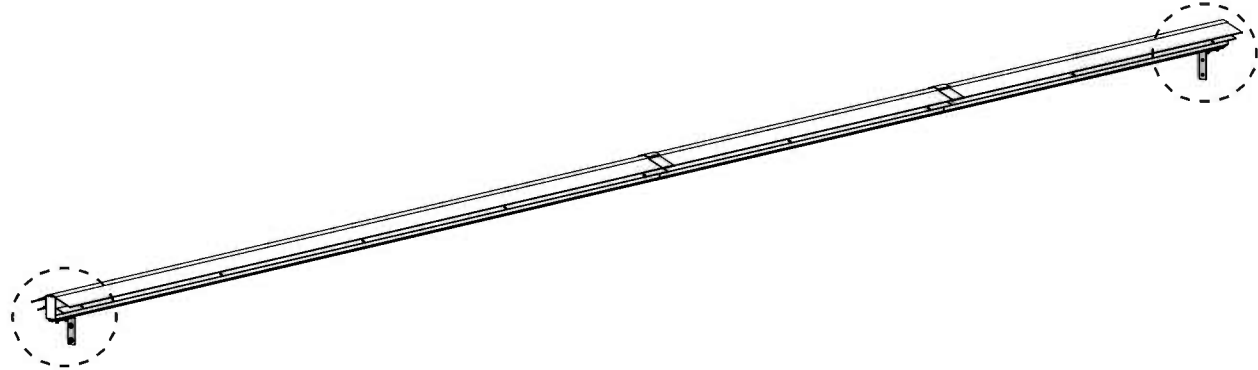
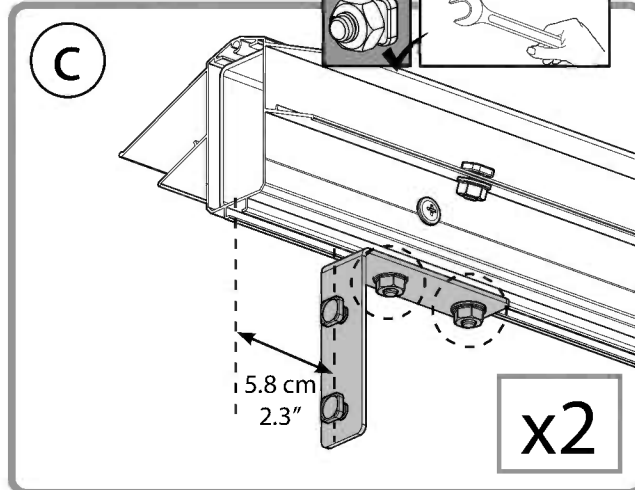



8848 .....

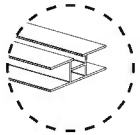
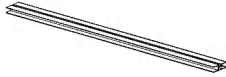

..... 2

411 .....



..... 2

466 .....



..... 2



10 mm

13/32"

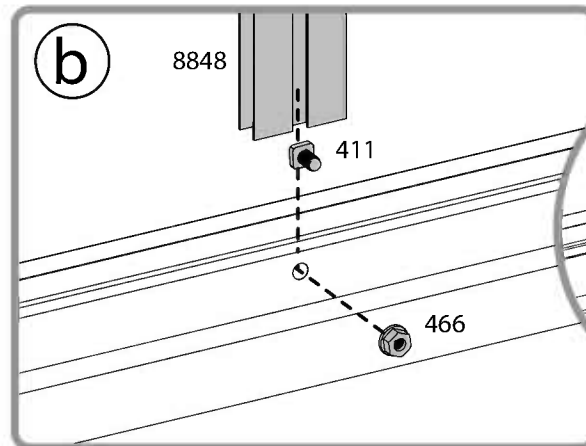
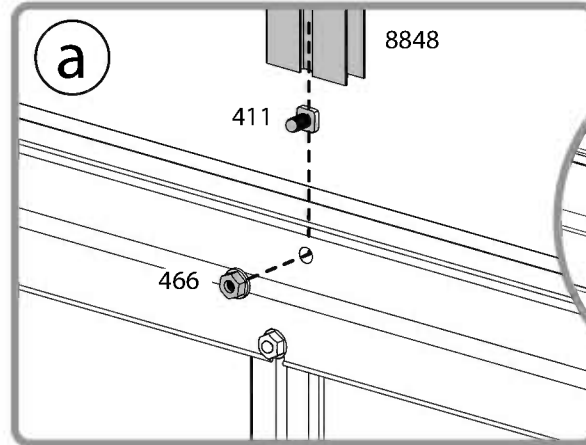
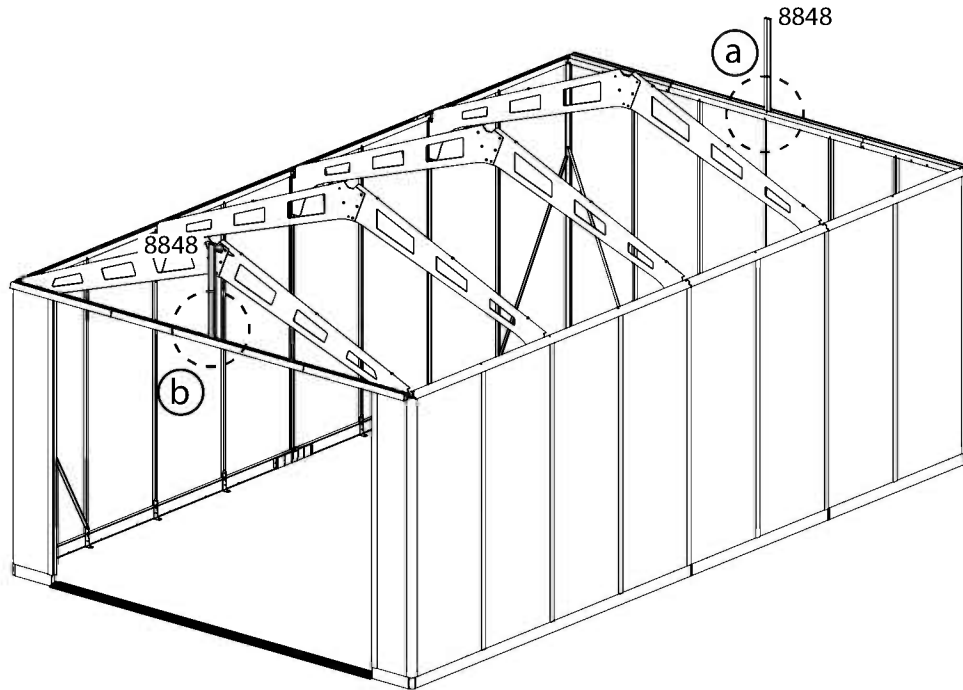



411 .....  ..... 18

466 .....  ..... 18



11'x21'

411 .....22

466 .....22

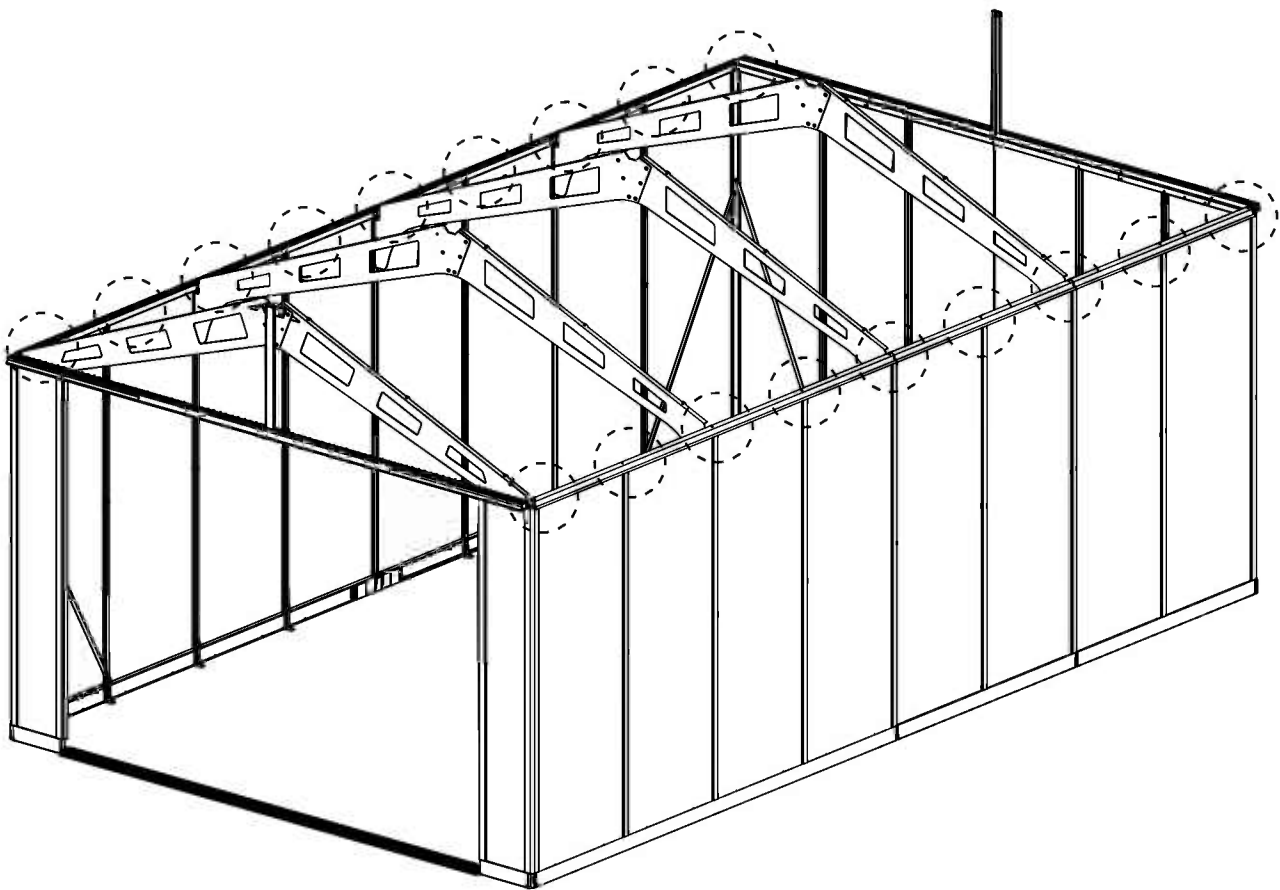

a

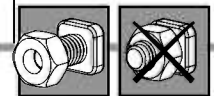
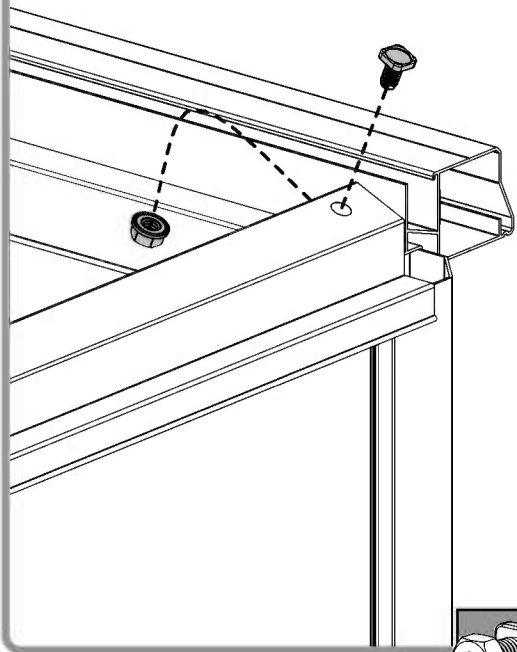

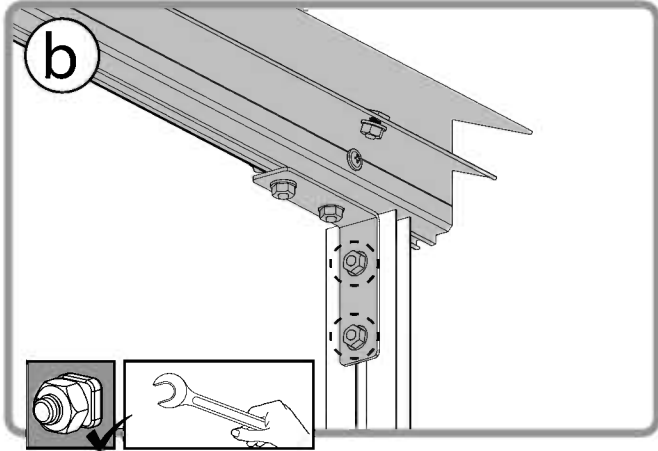
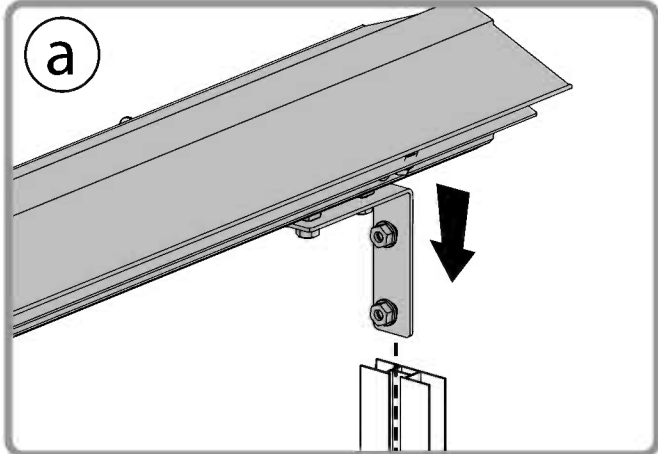
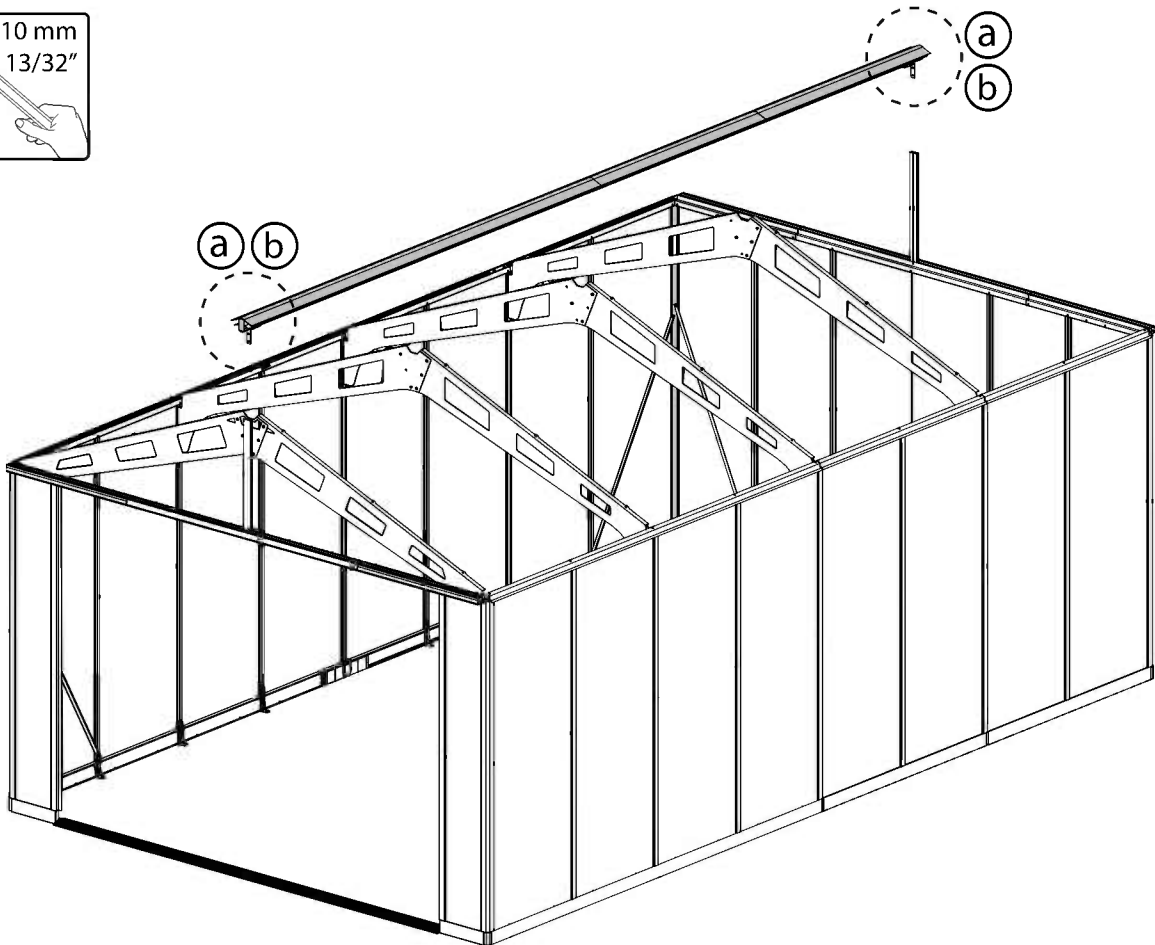
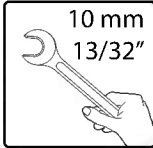



8847 .....

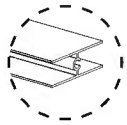

..... 4

8860 .....

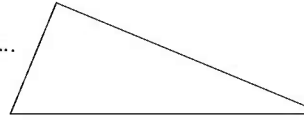

..... 2

8861 .....

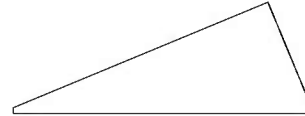

..... 2

8862 .....

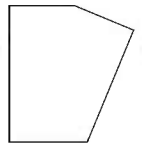

..... 2

8863 .....

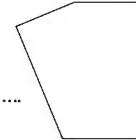

..... 2

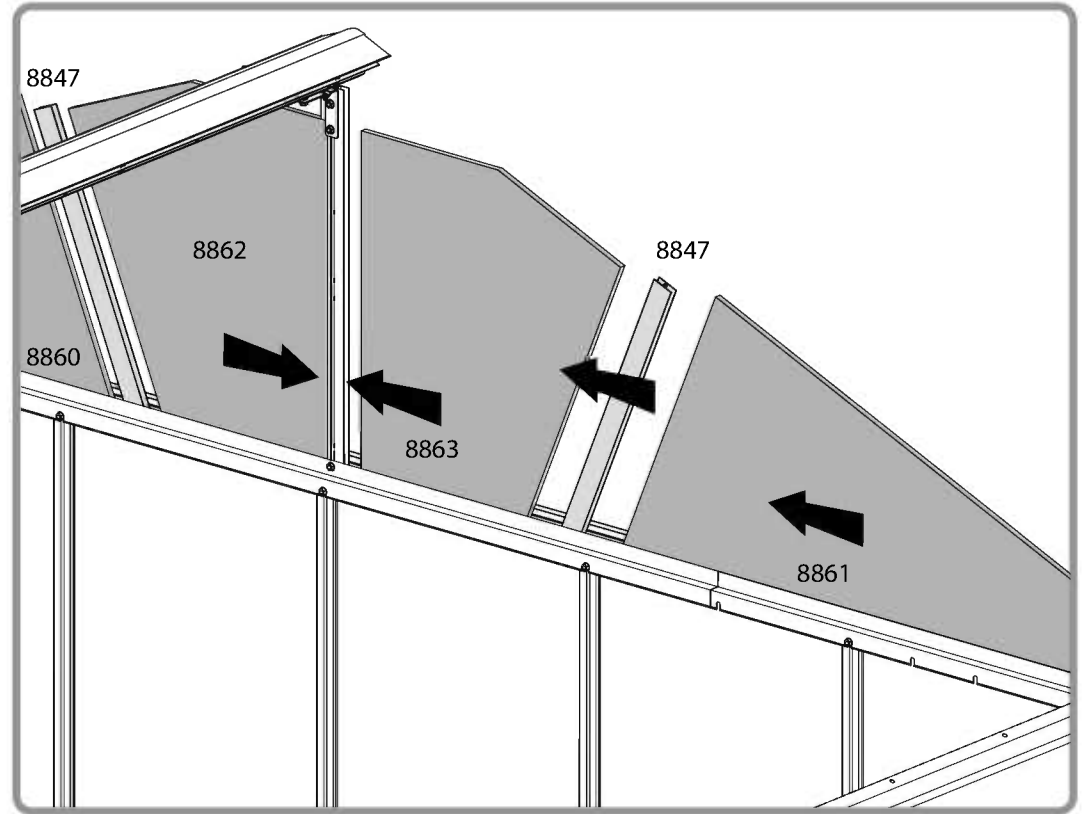
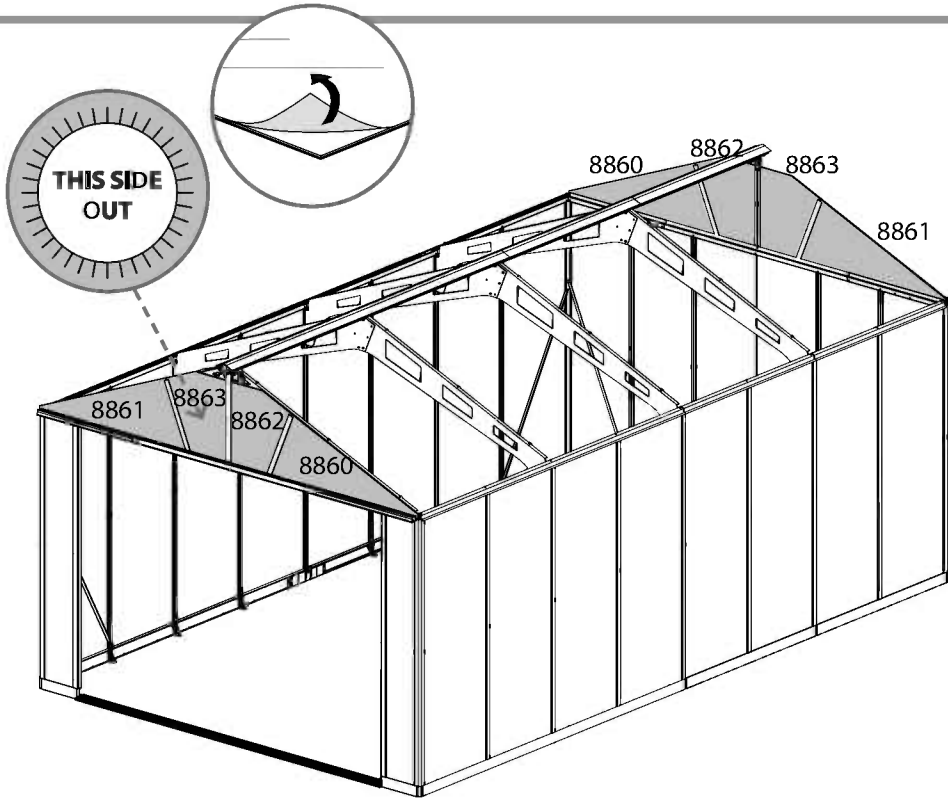



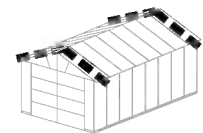

8846 .....

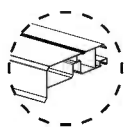
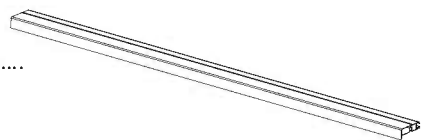

..... 4

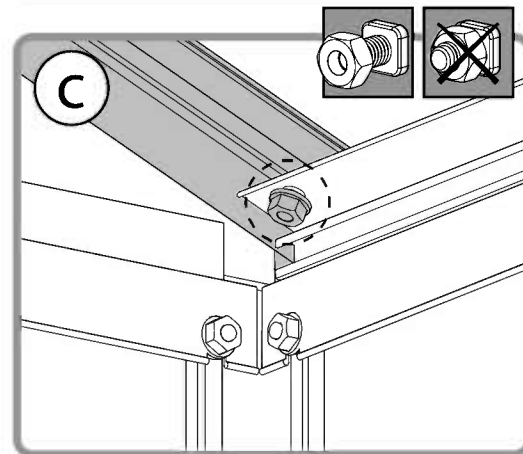
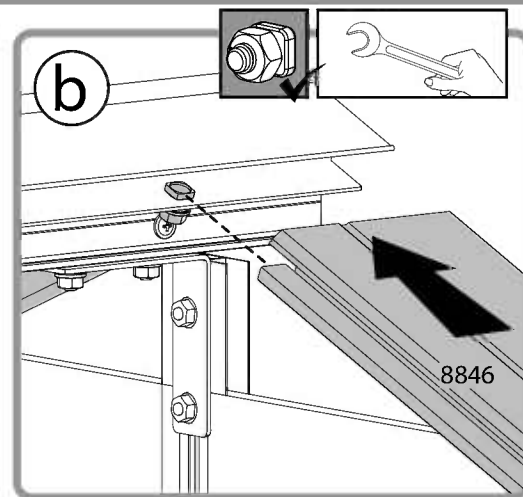
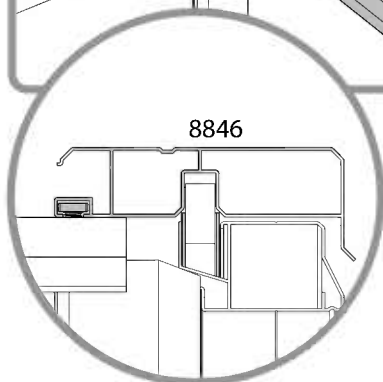
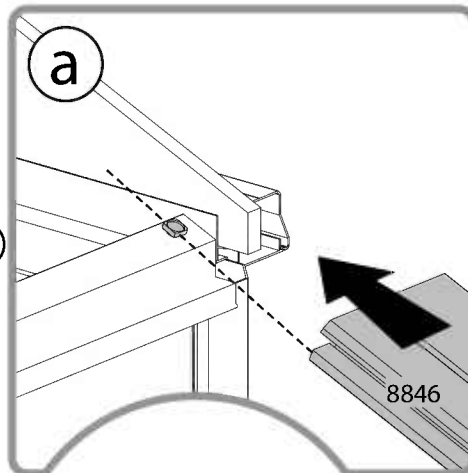
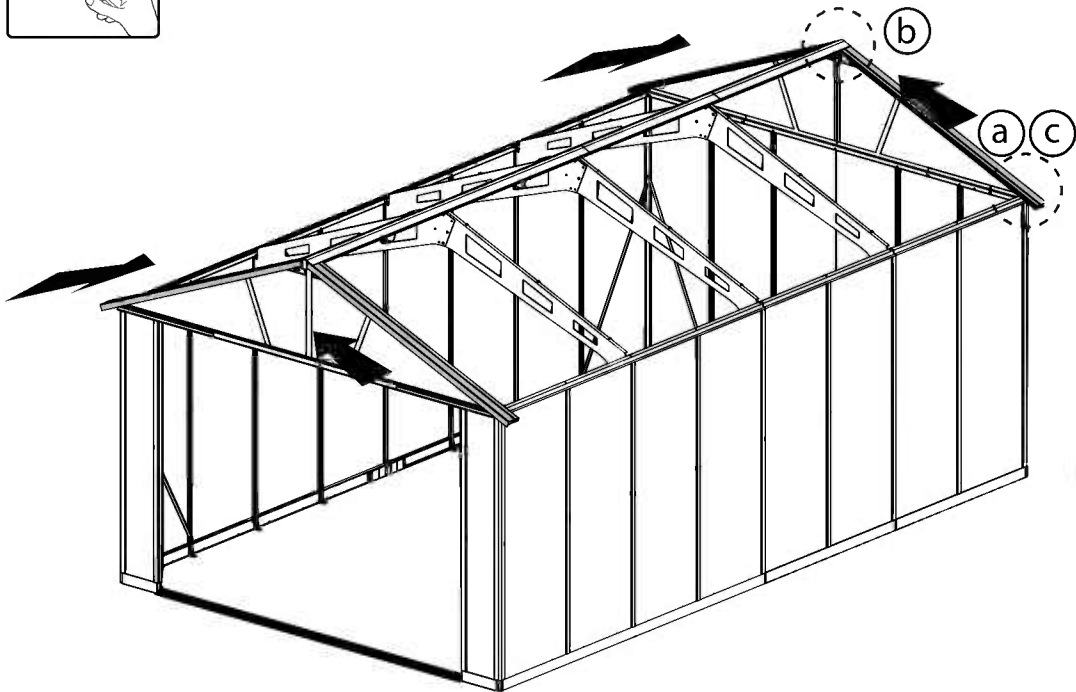

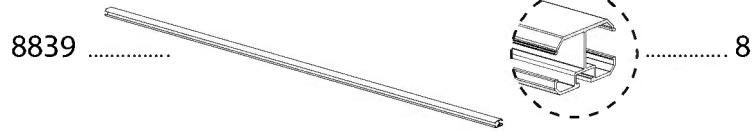

8839 ..... 10

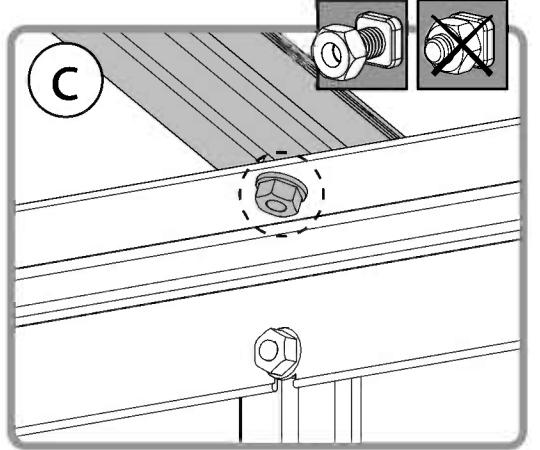
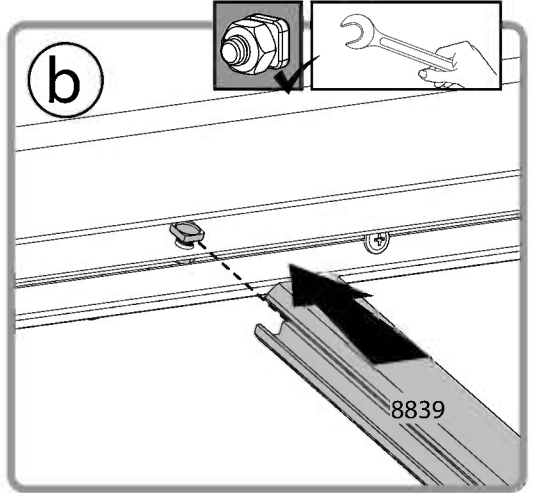
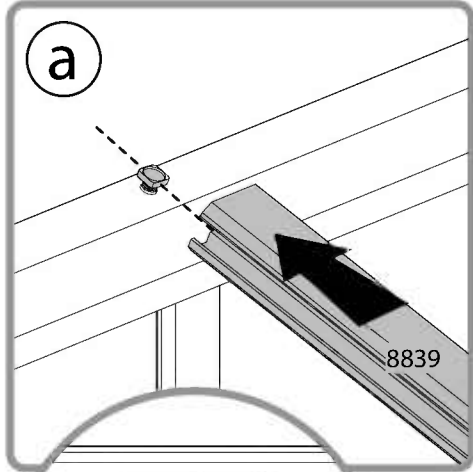
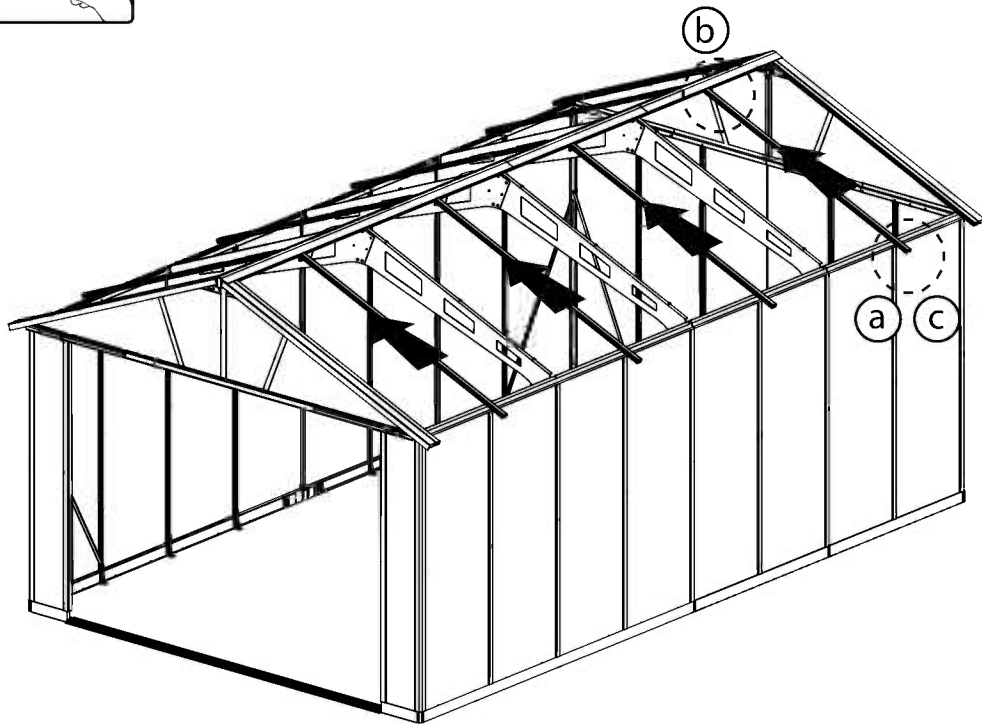

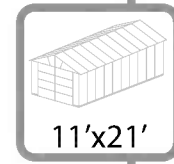
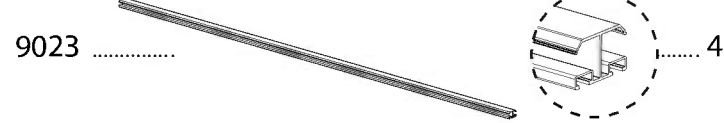
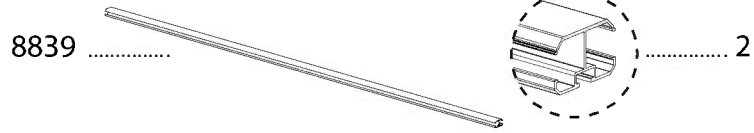

- 8839 ..... 2
- 9023 ..... 6

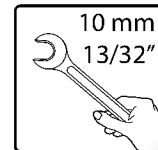
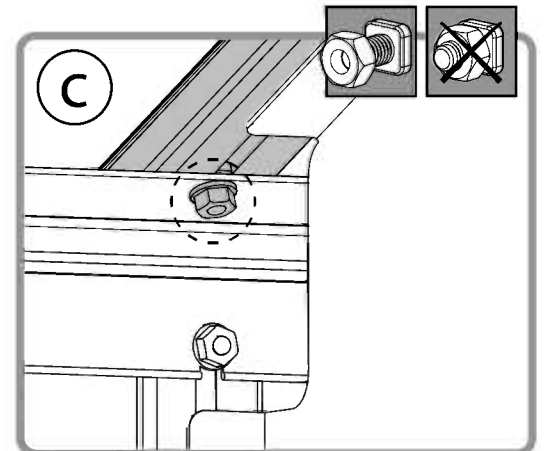
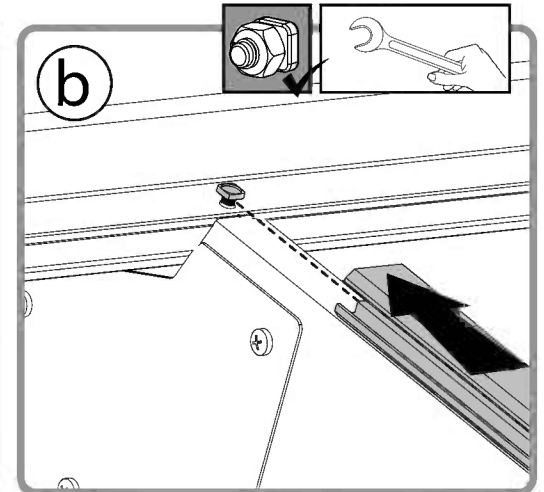
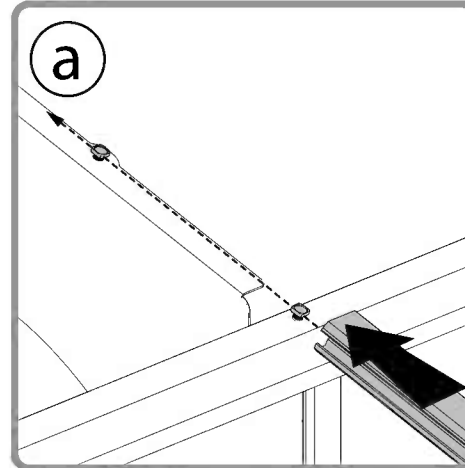
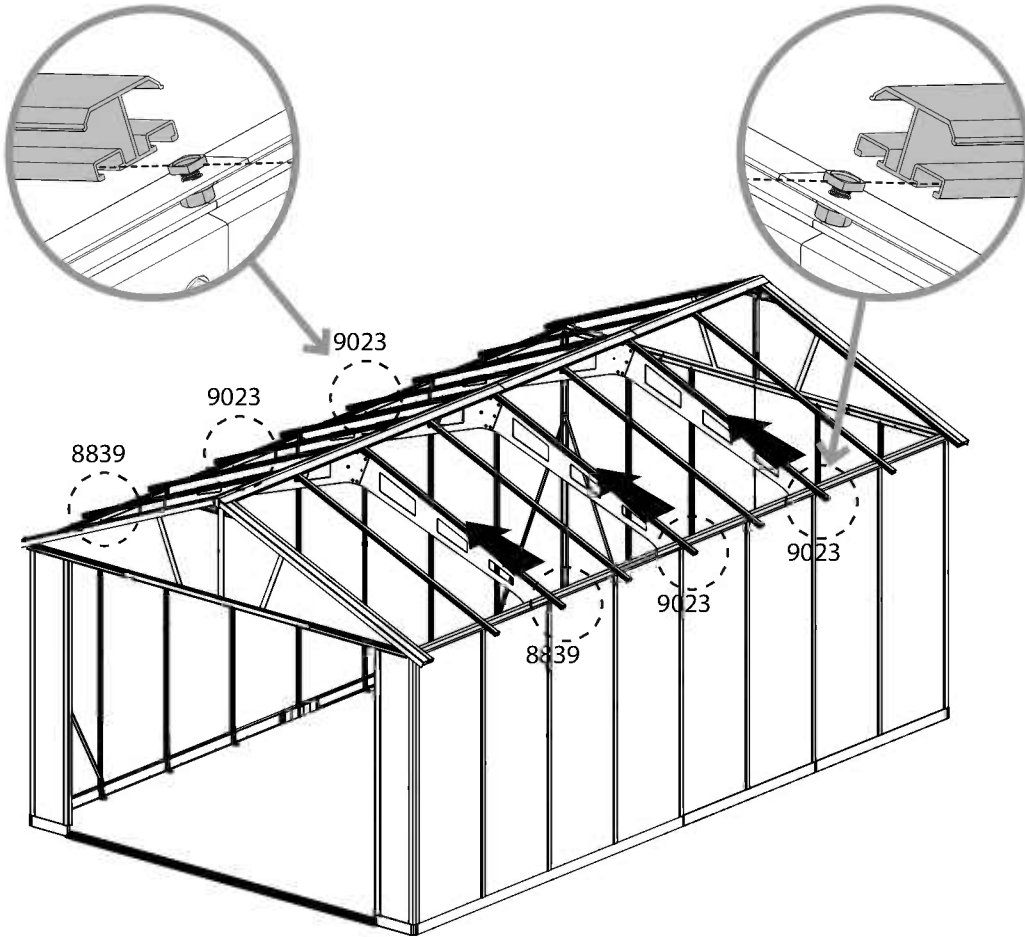

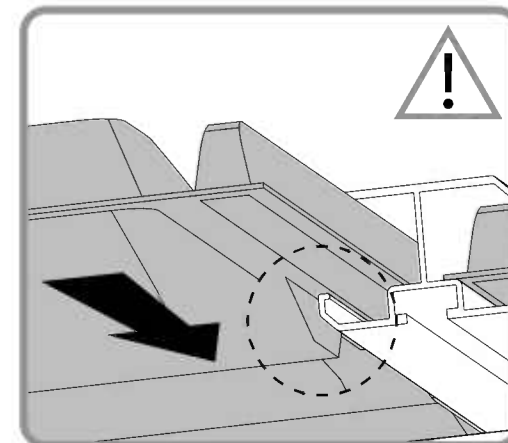
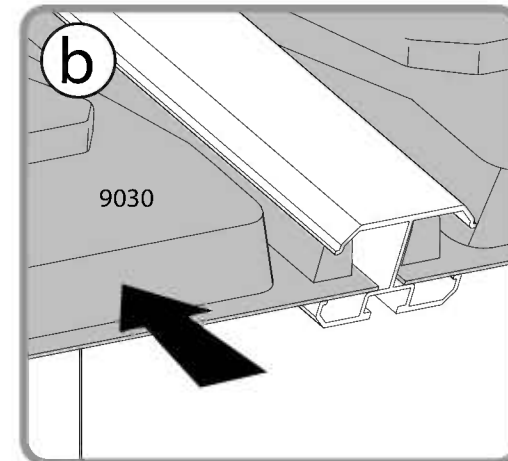
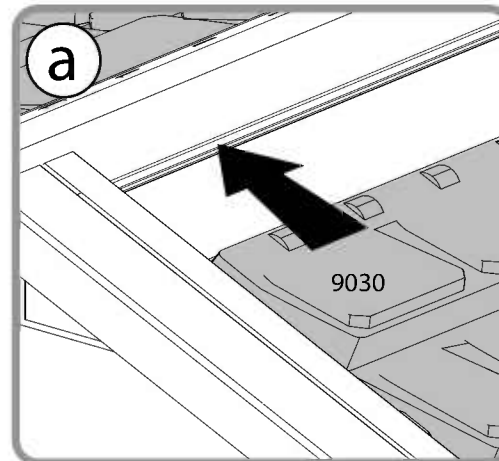
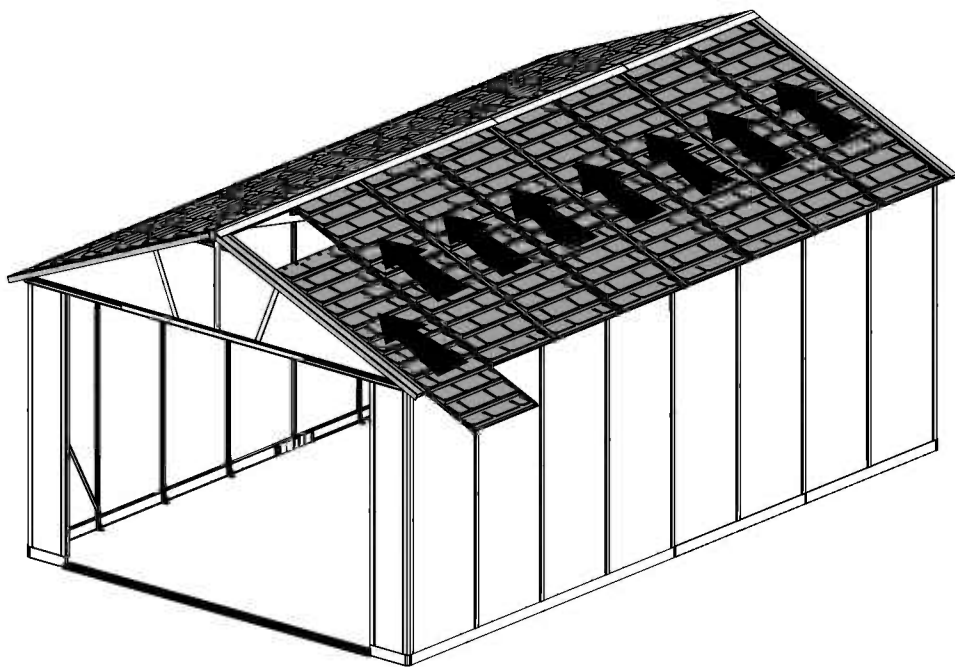
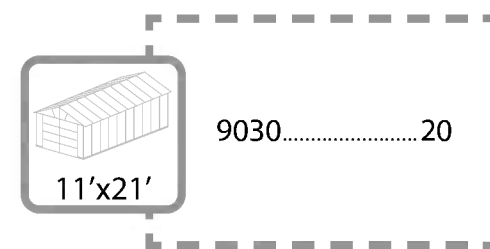
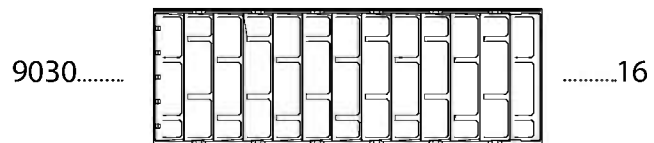

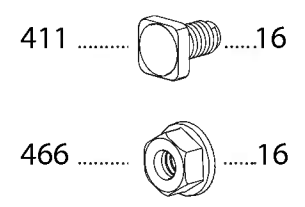
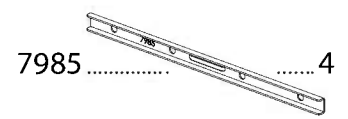
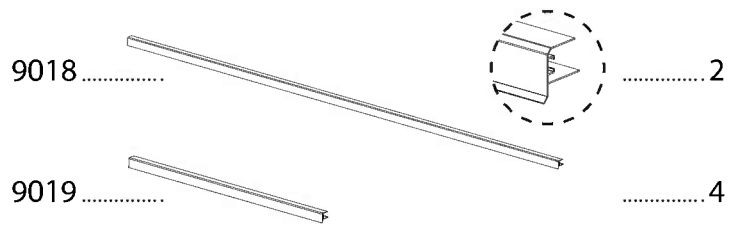

- EN** Slow down and be careful when sliding the panels in
- DE** Seien Sie langsam und vorsichtig beim Einschieben der Paneele
- FR** Ralentez et faites attention lorsque vous y glissez les panneaux
- SP** Al deslizar los paneles hacia adentro, desacelere y tenga cuidado

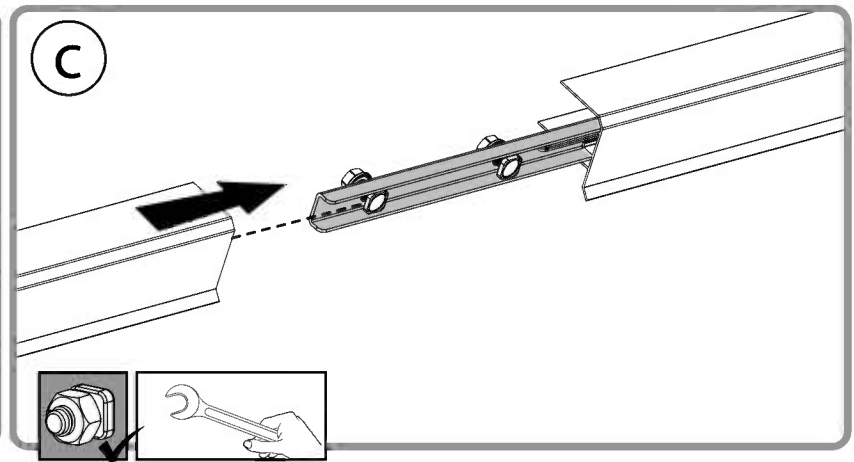
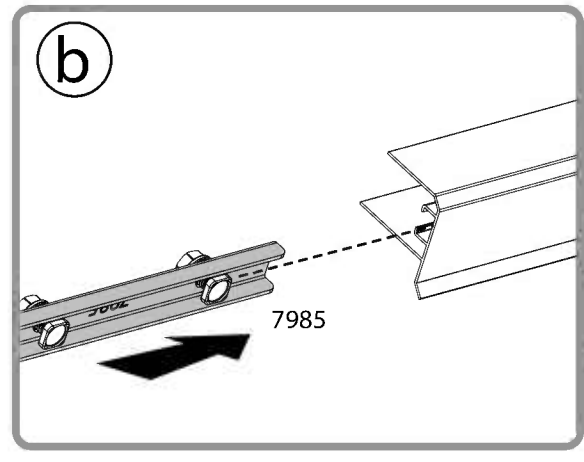
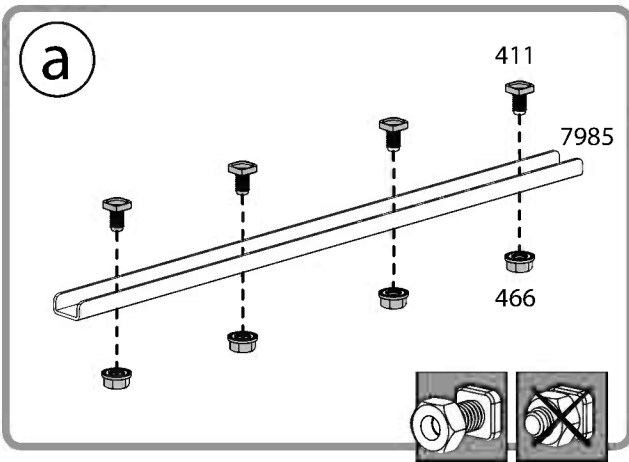
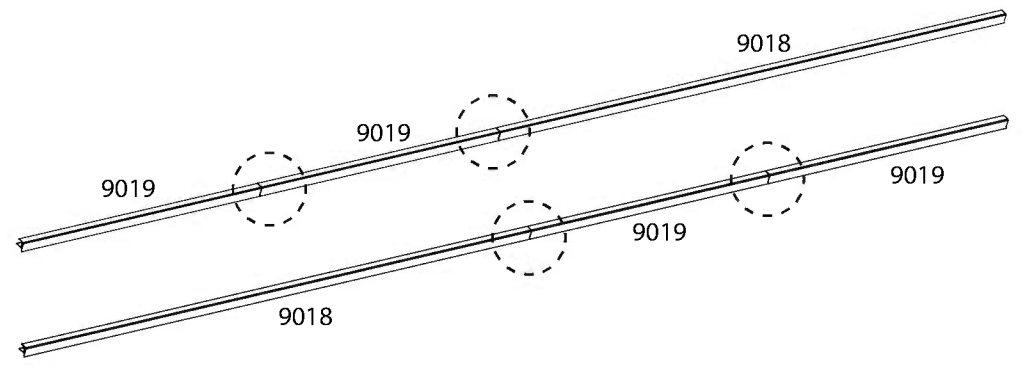

<p>11'x21'</p>	9018.....	2
	9019.....	6
	7985.....	6
	411 .....	24
	466 .....	24

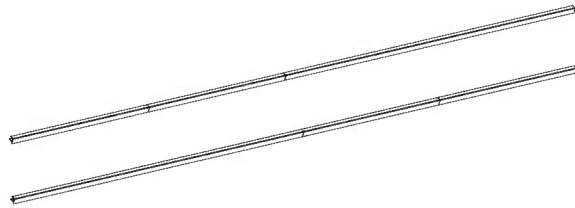



411 .....  ..... 18

466 .....  ..... 18

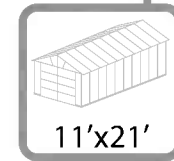

411 ..... 22  
466 ..... 22

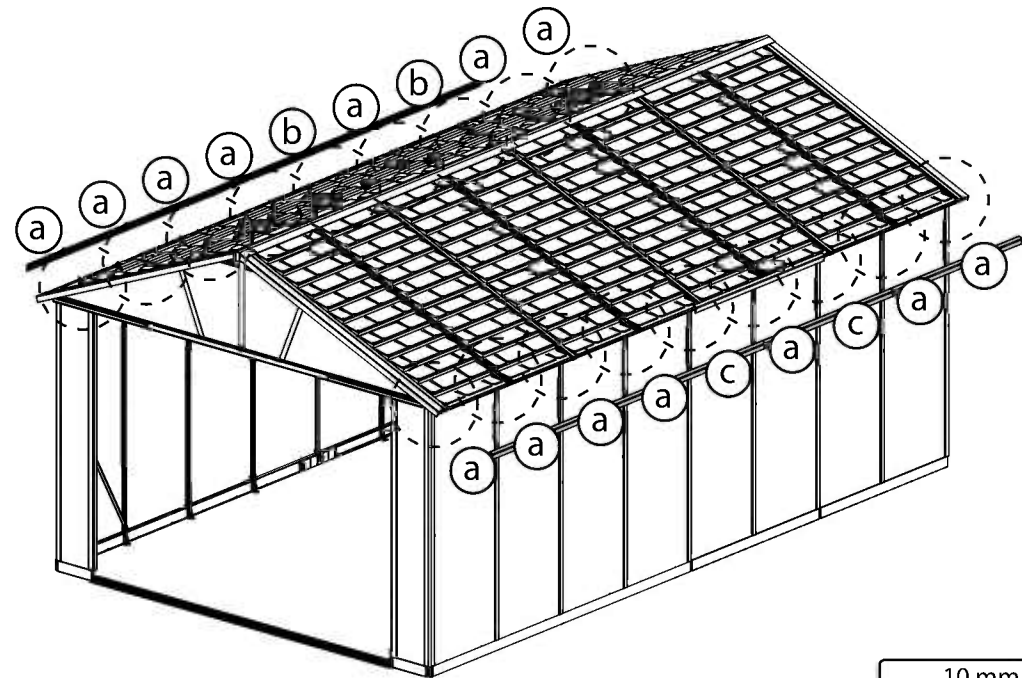
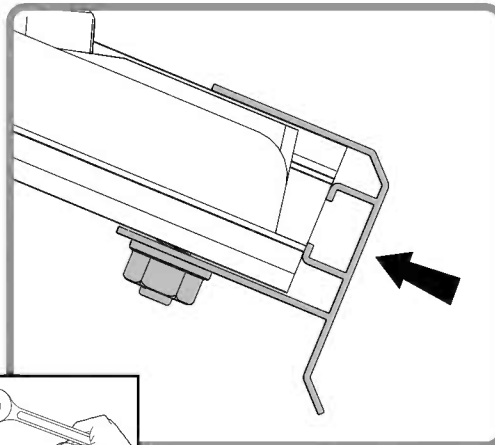
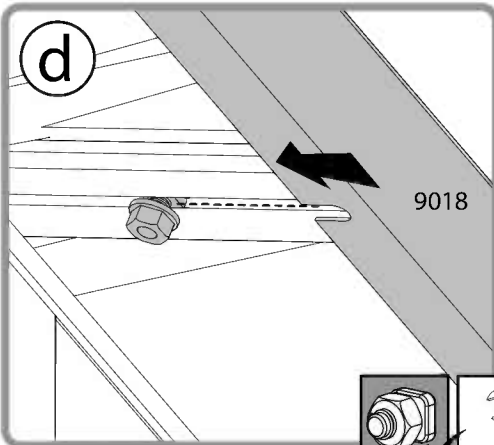
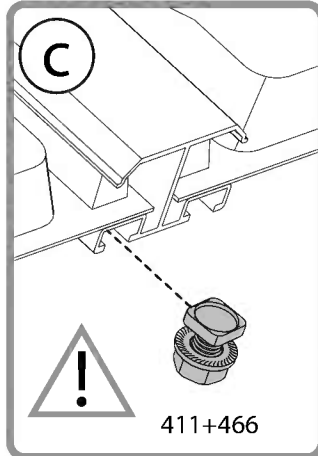
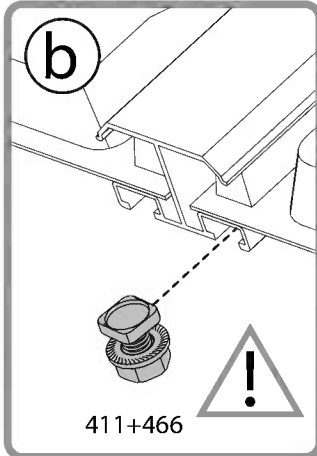
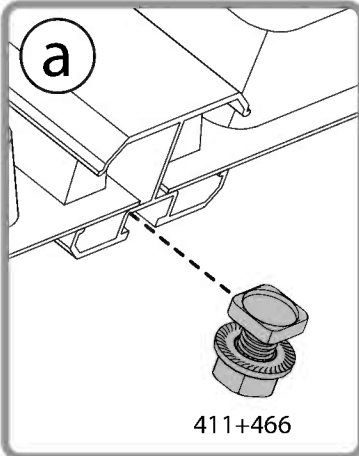

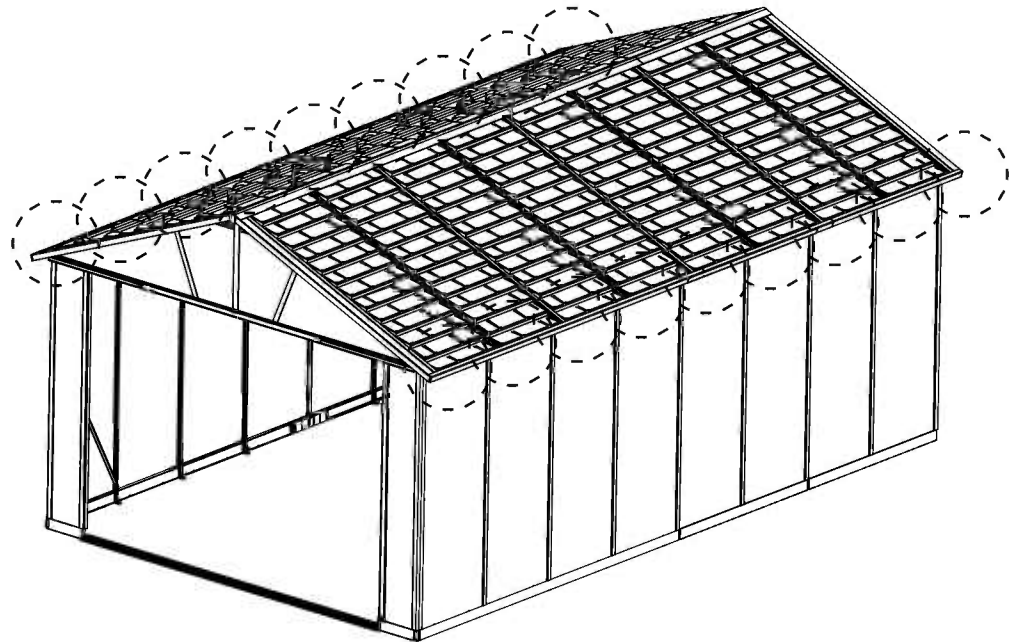
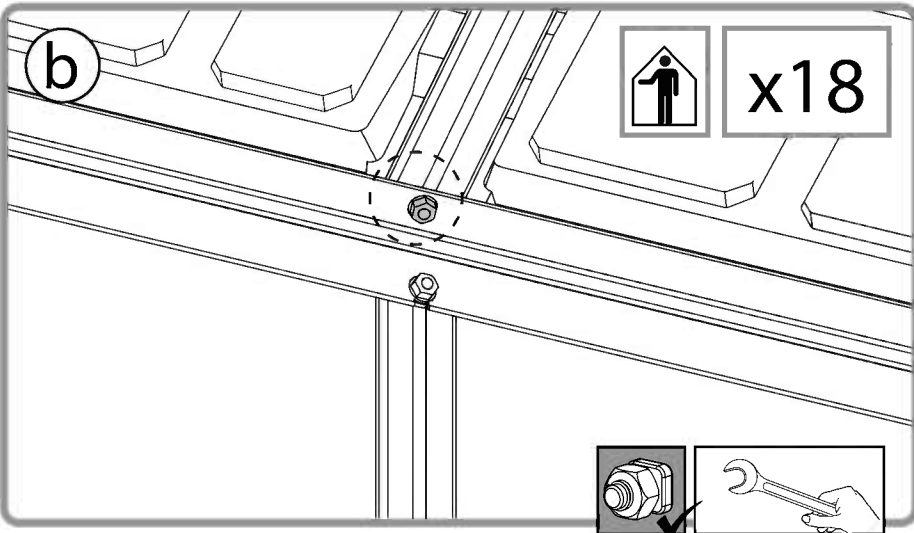
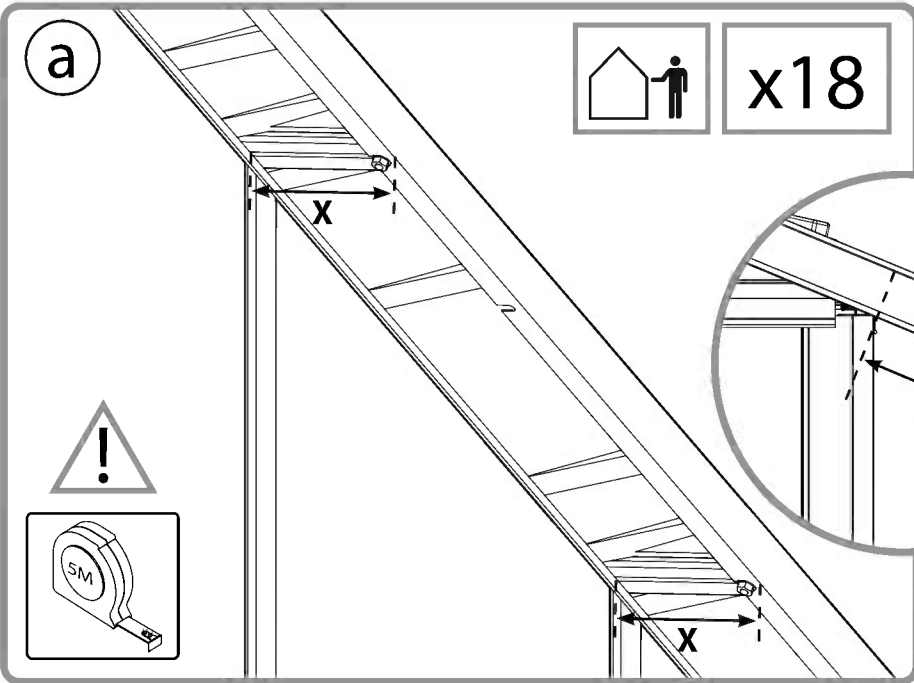

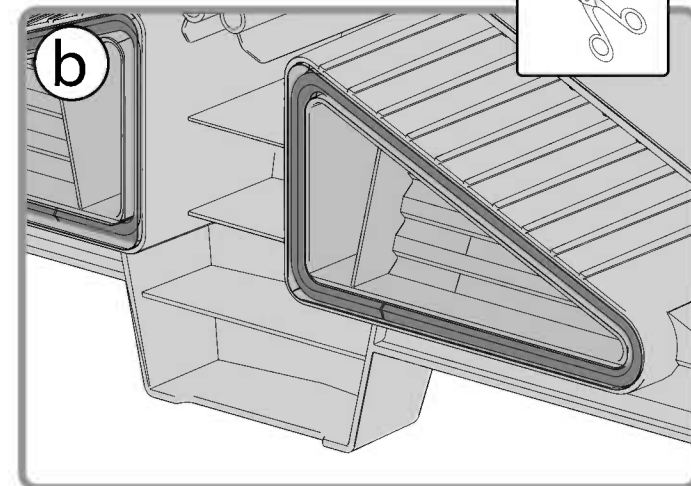
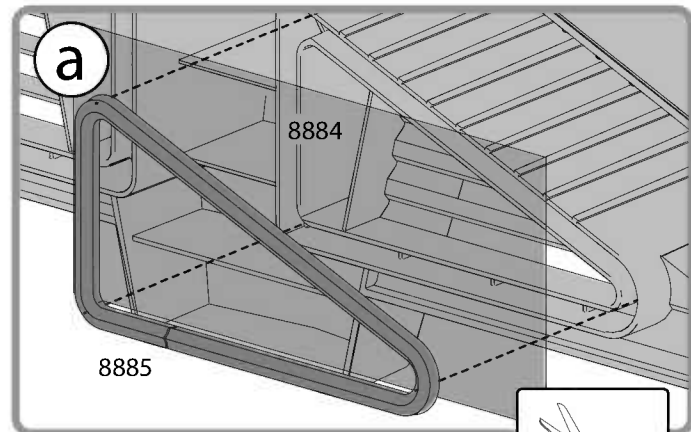
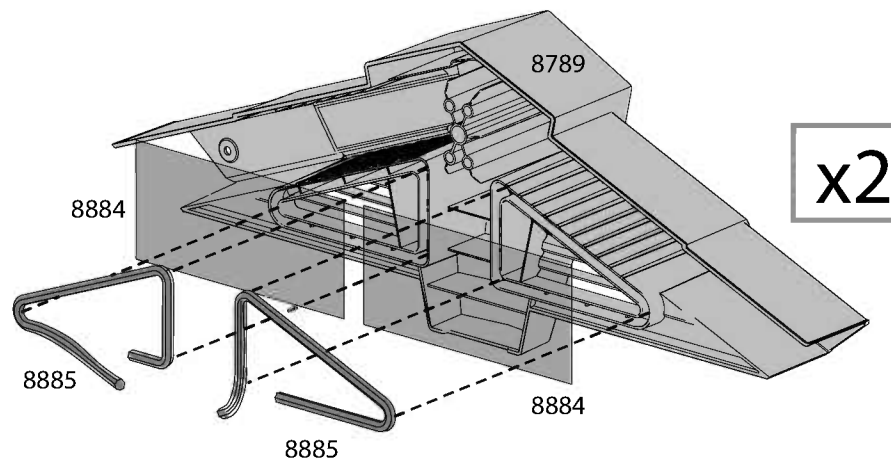
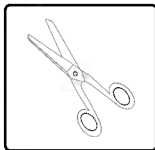
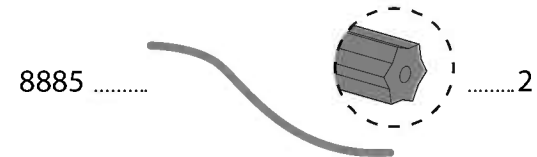
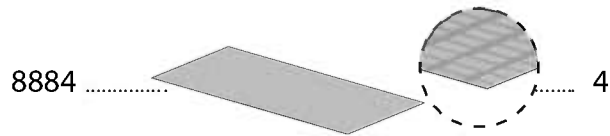
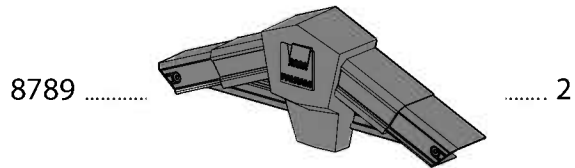
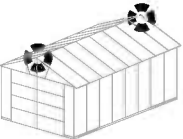



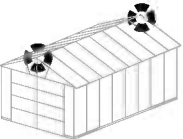

4008 .....  ..... 4

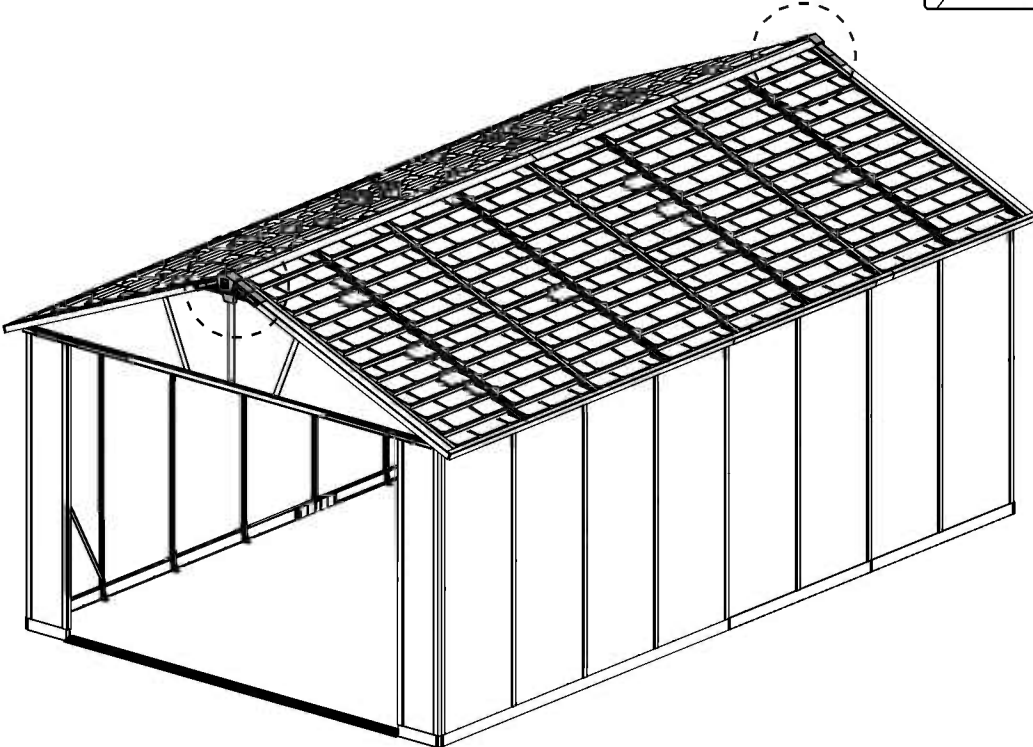
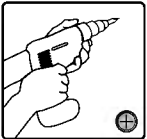
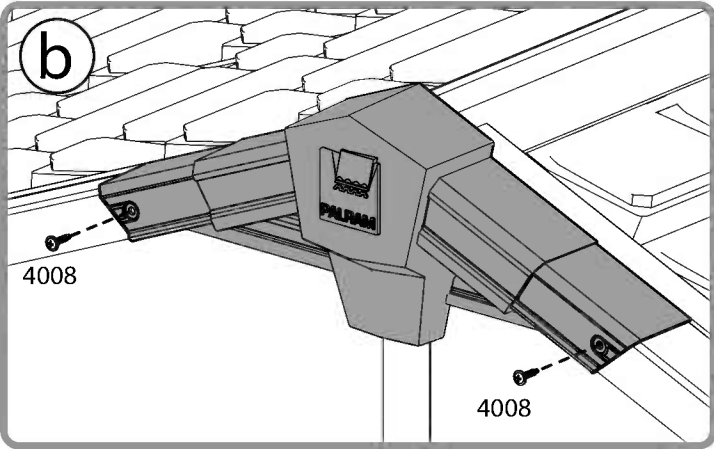
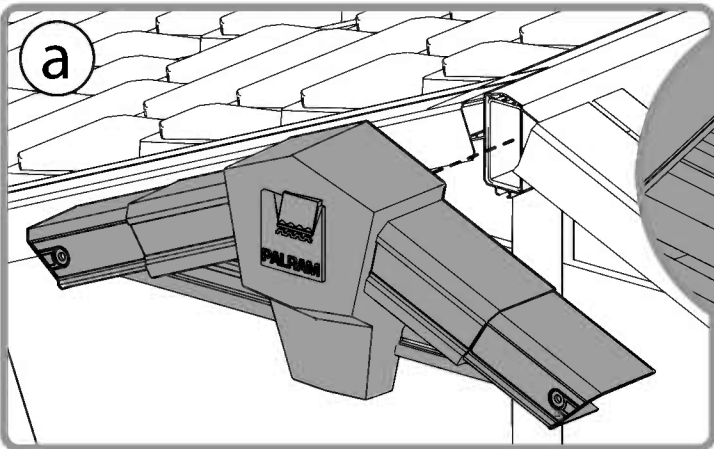

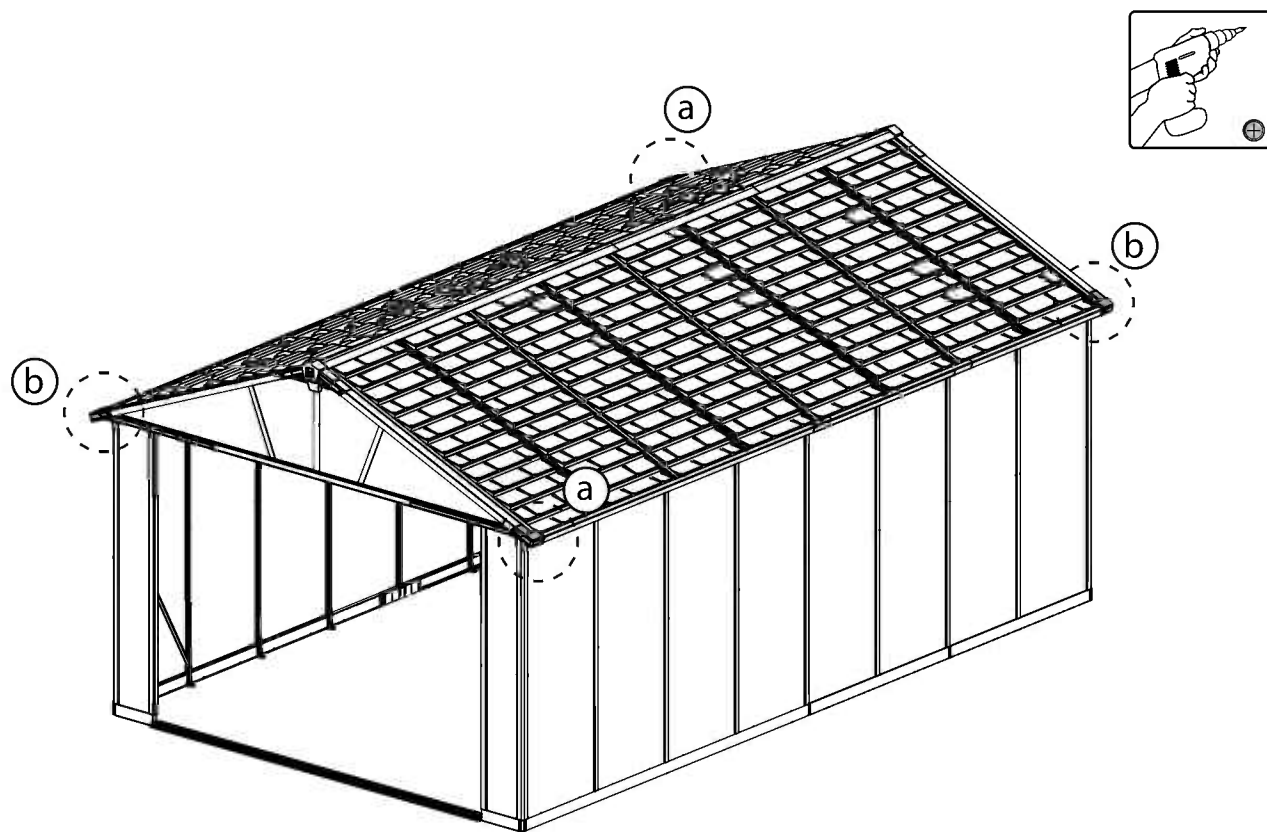
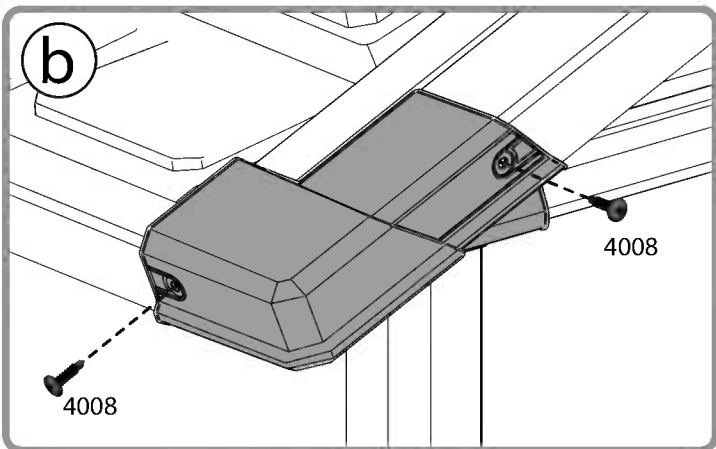
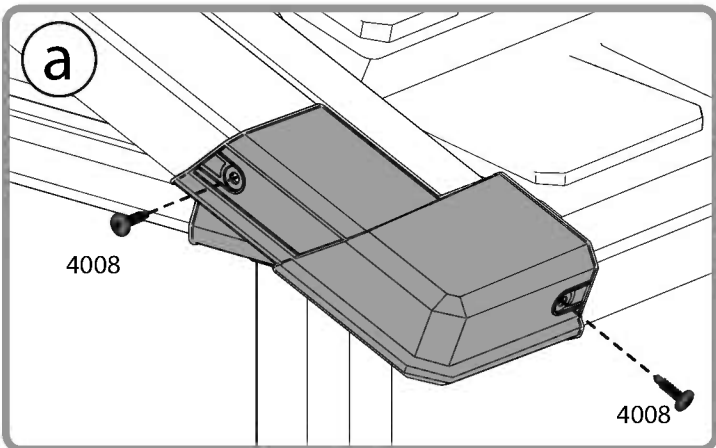
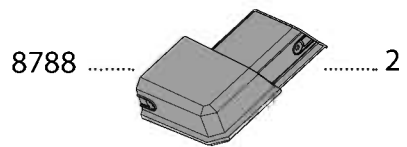
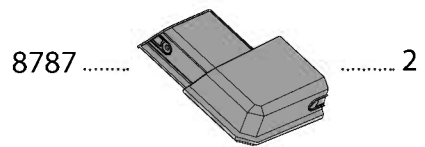
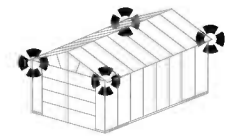

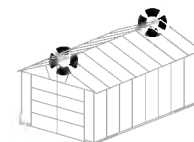

8883 ..... 4

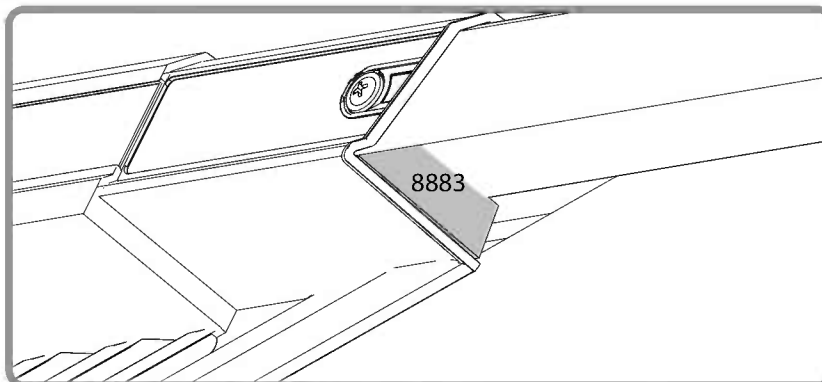
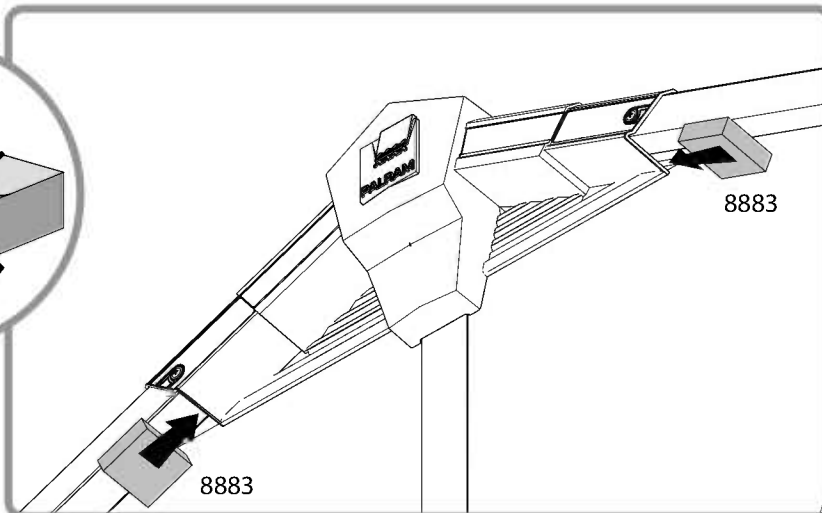
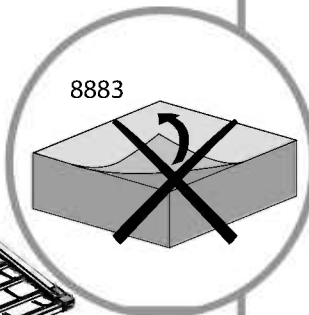
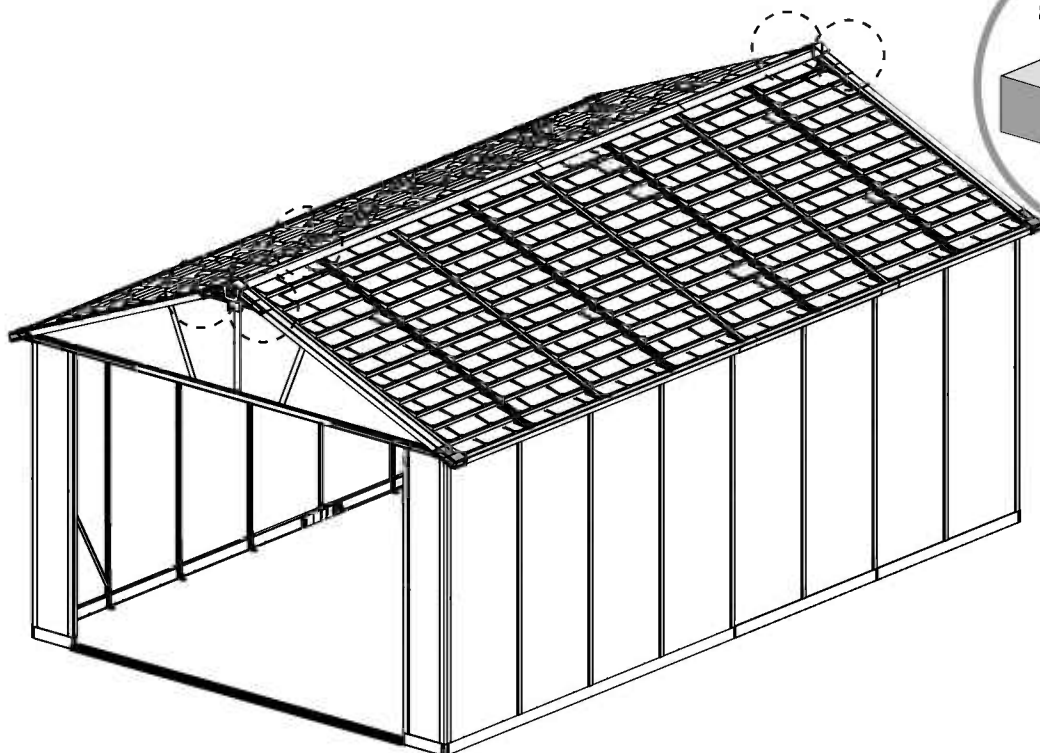

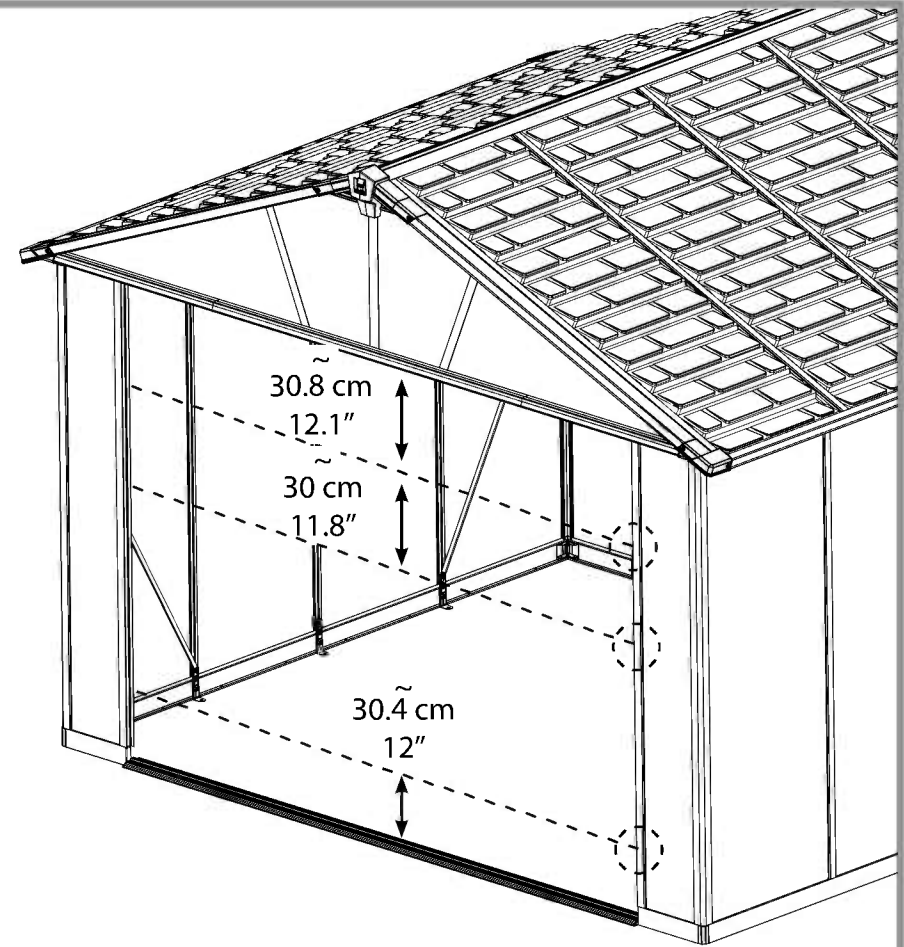
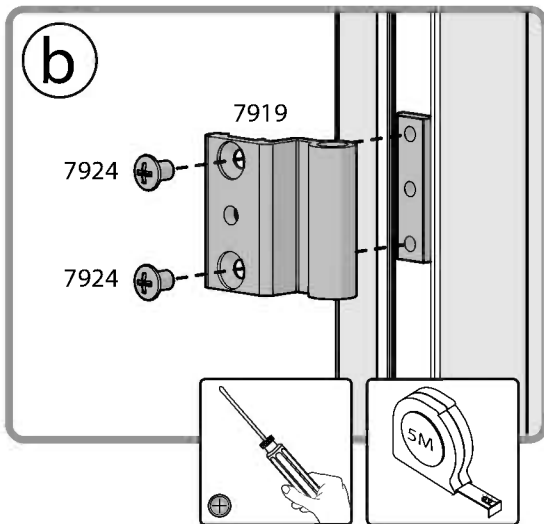
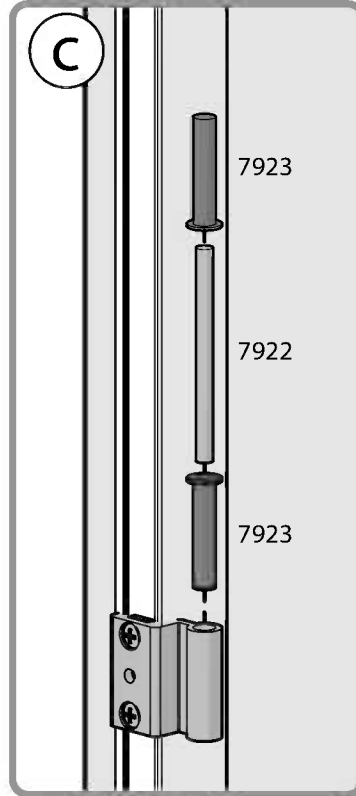
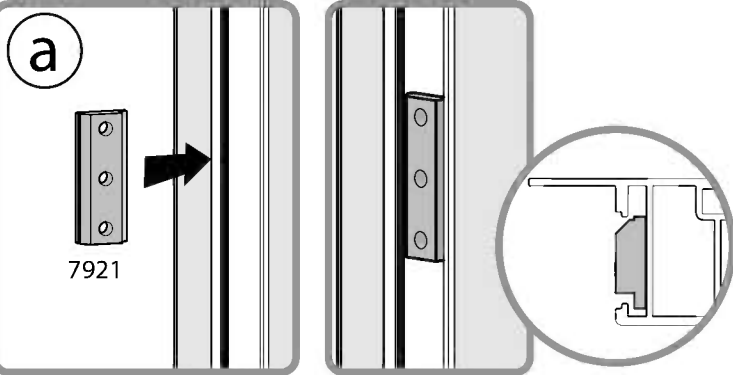
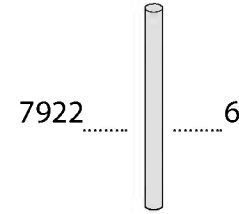
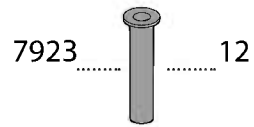
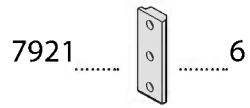
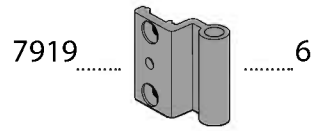



9474 ..... 1

9473 ..... 1

9471 ..... 6

7524 ..... 6

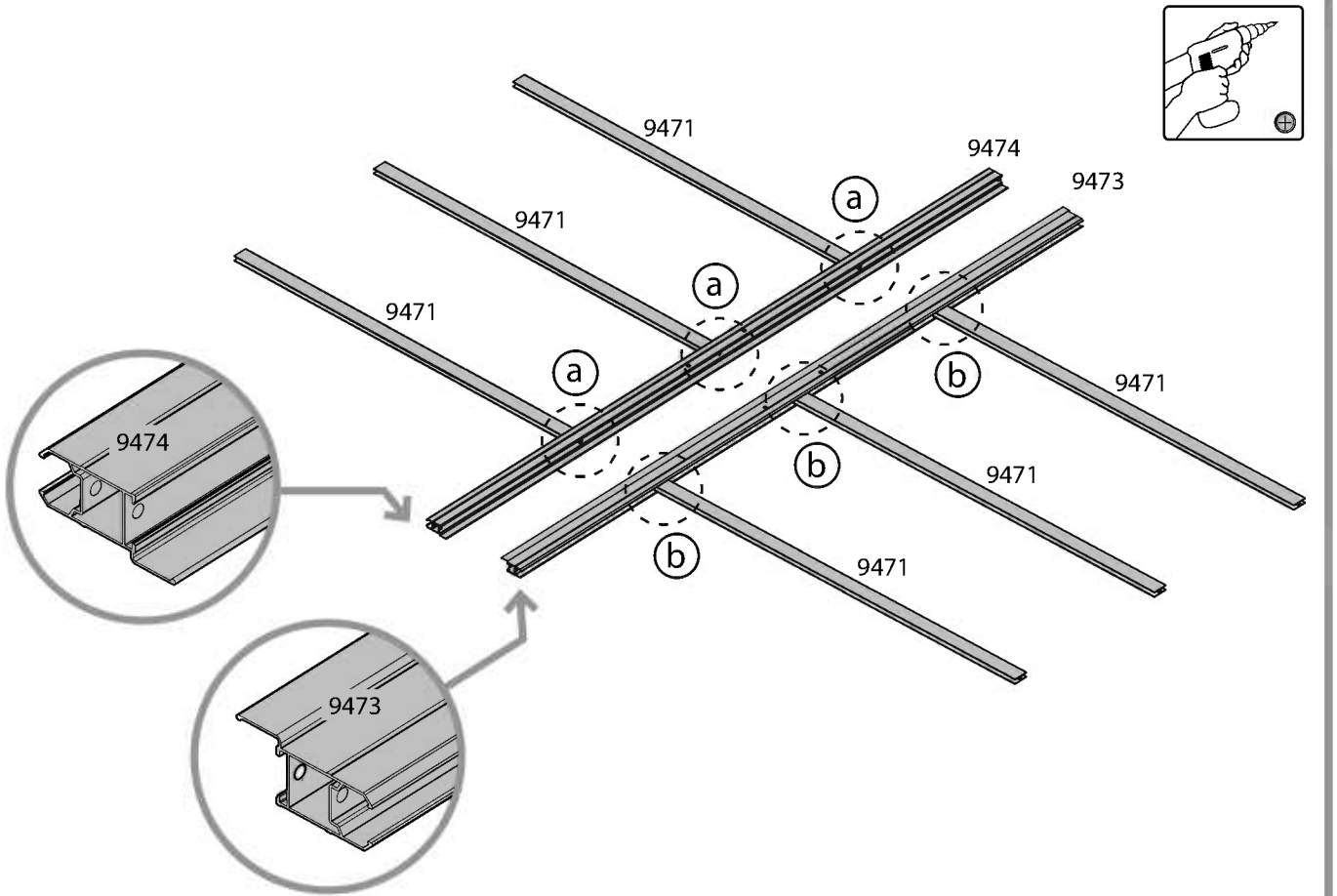
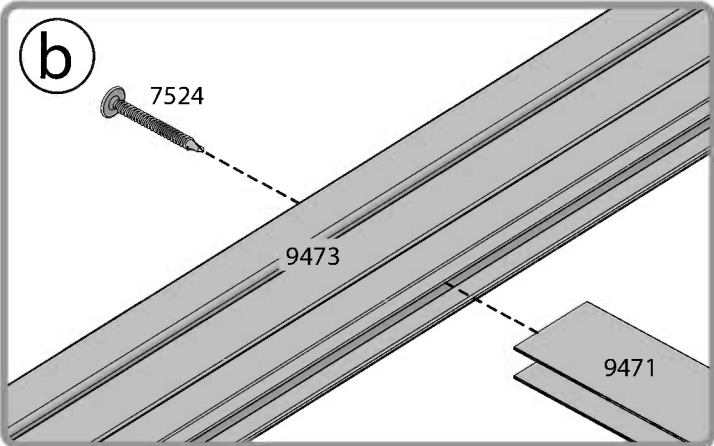
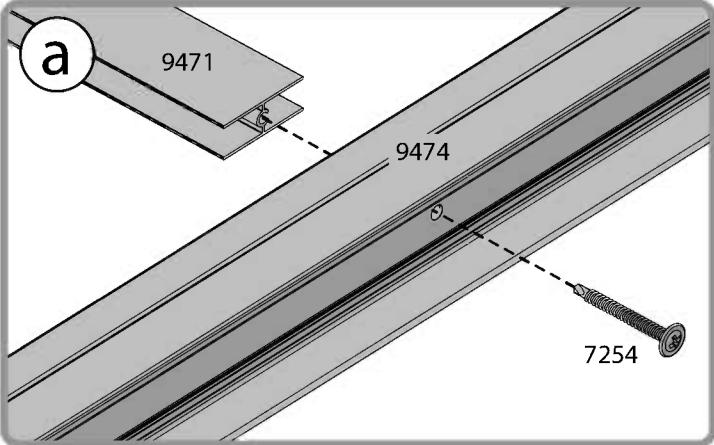

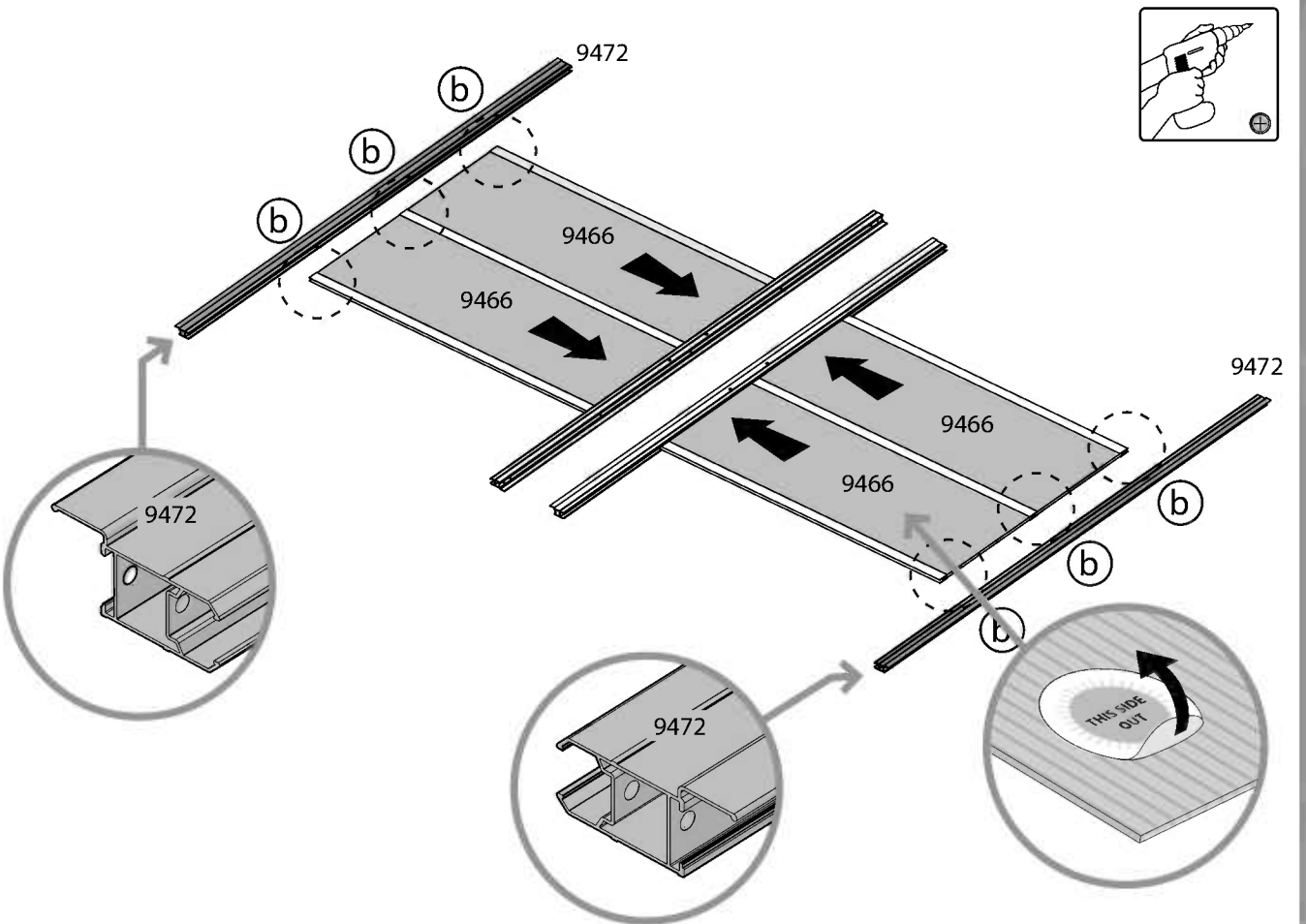
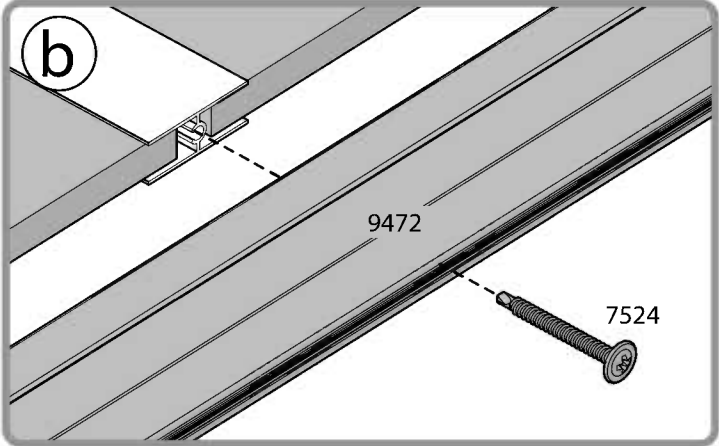
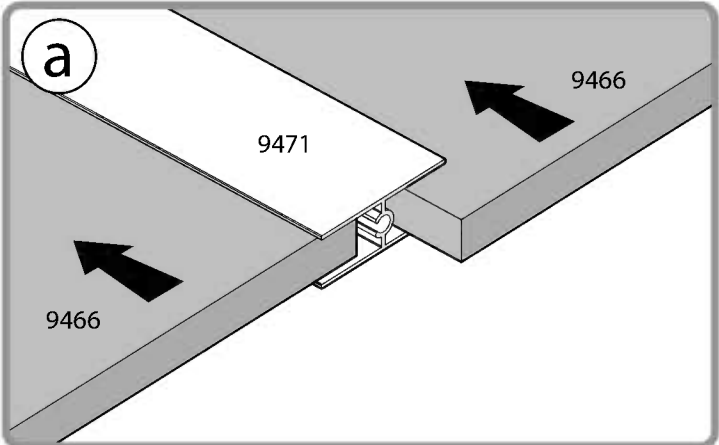
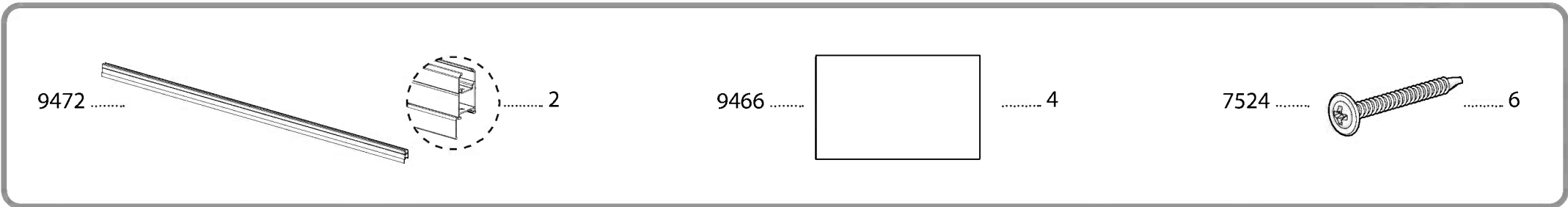

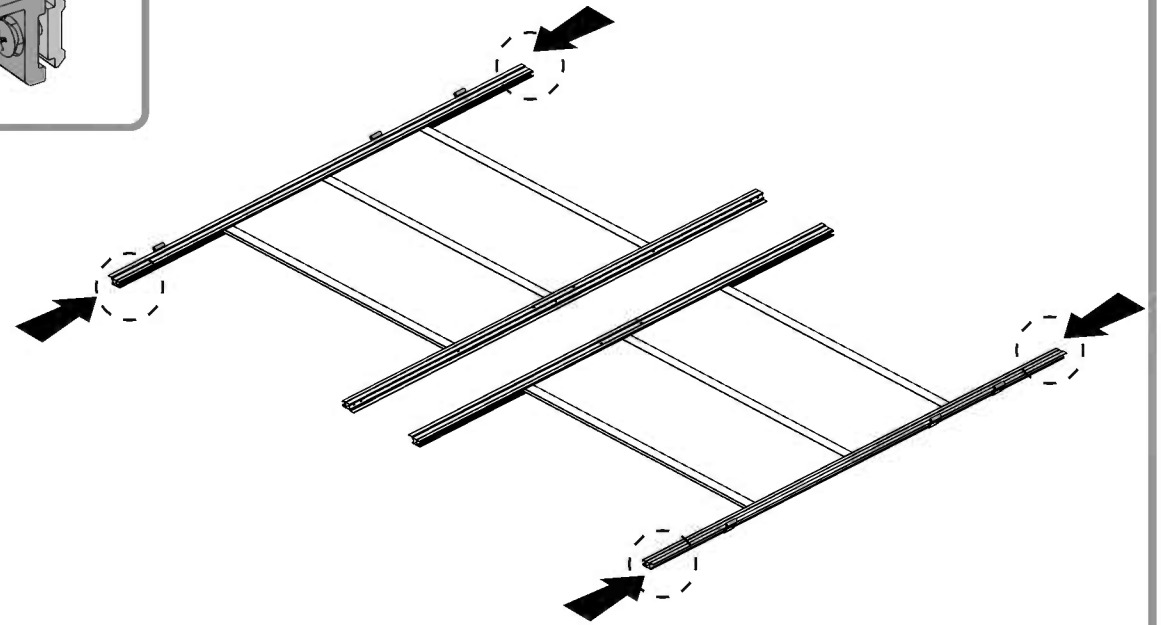
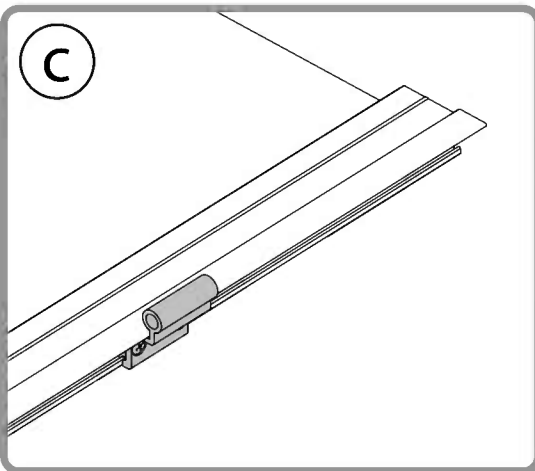
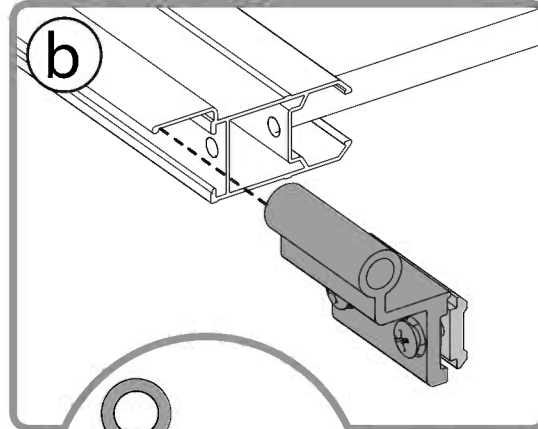
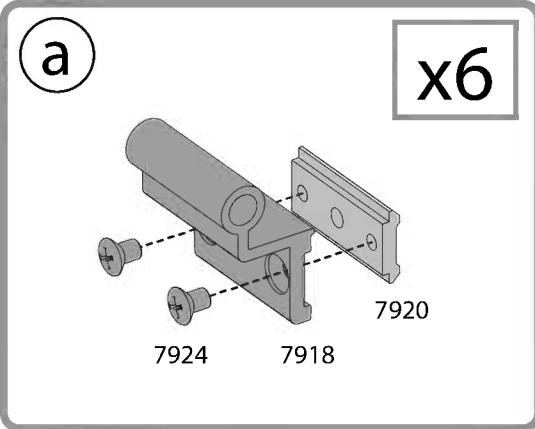
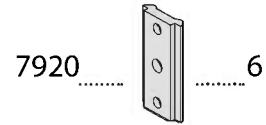
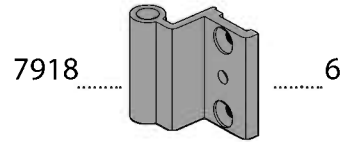

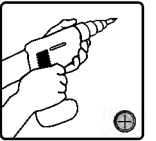
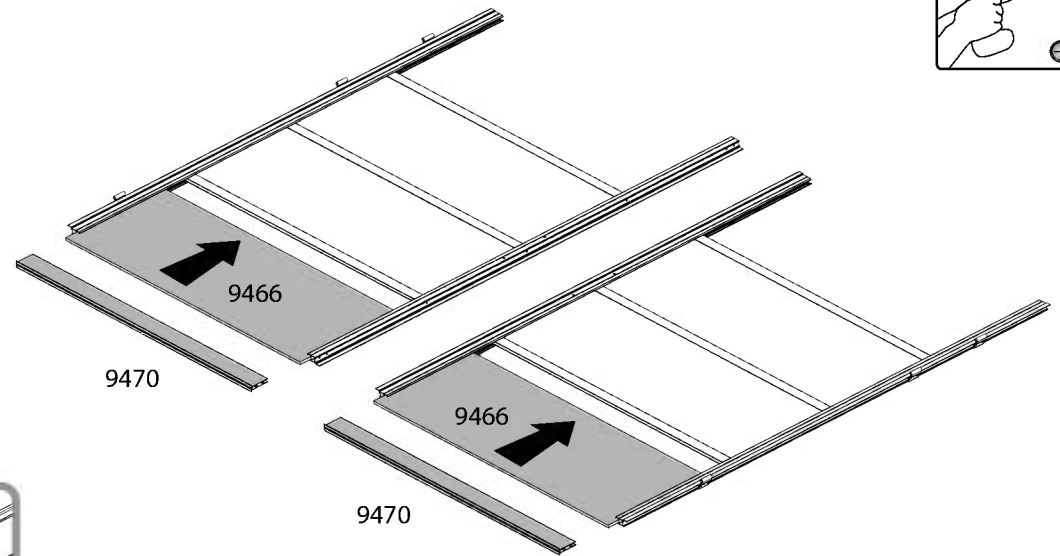
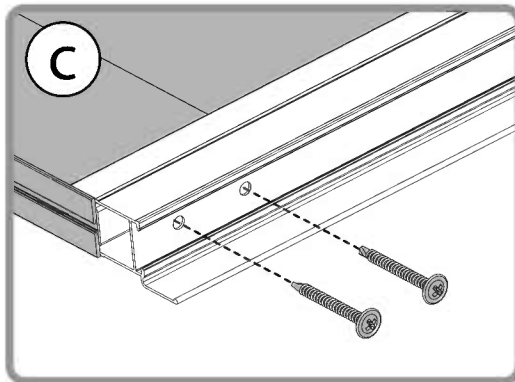
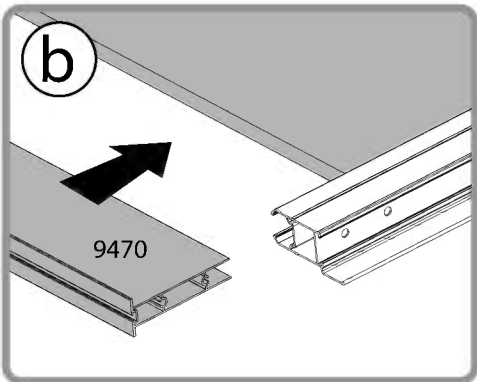
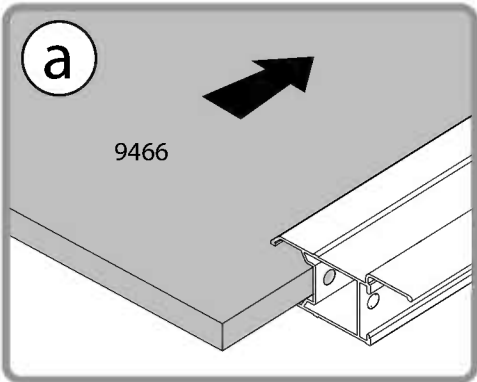
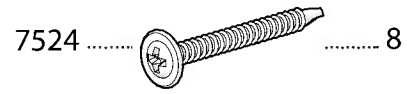
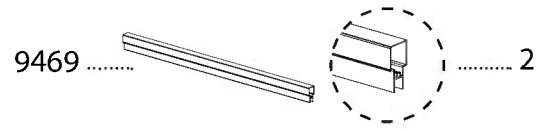



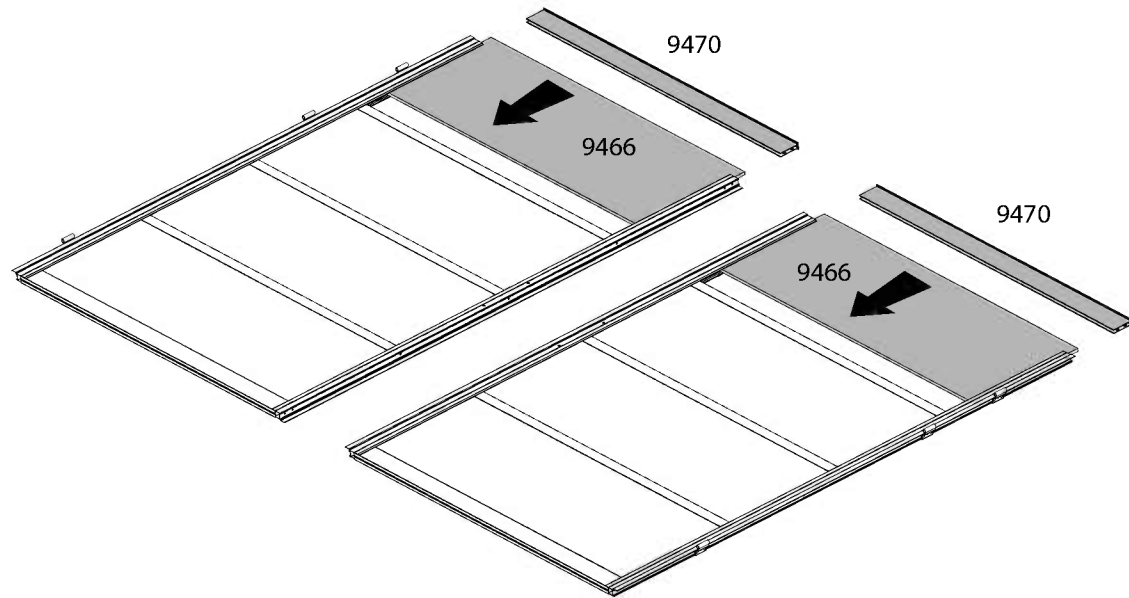
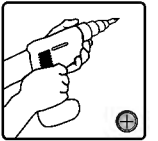
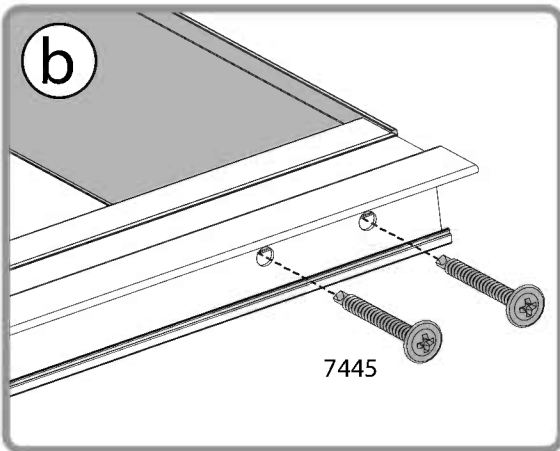
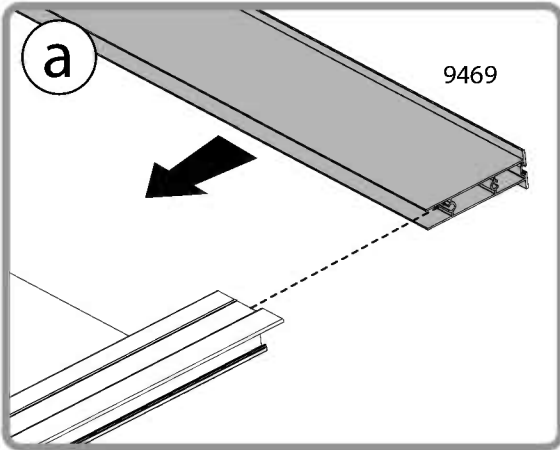
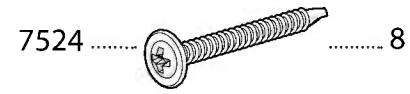
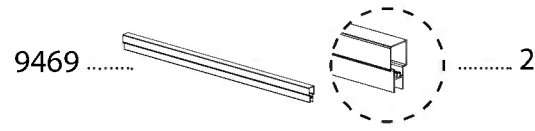

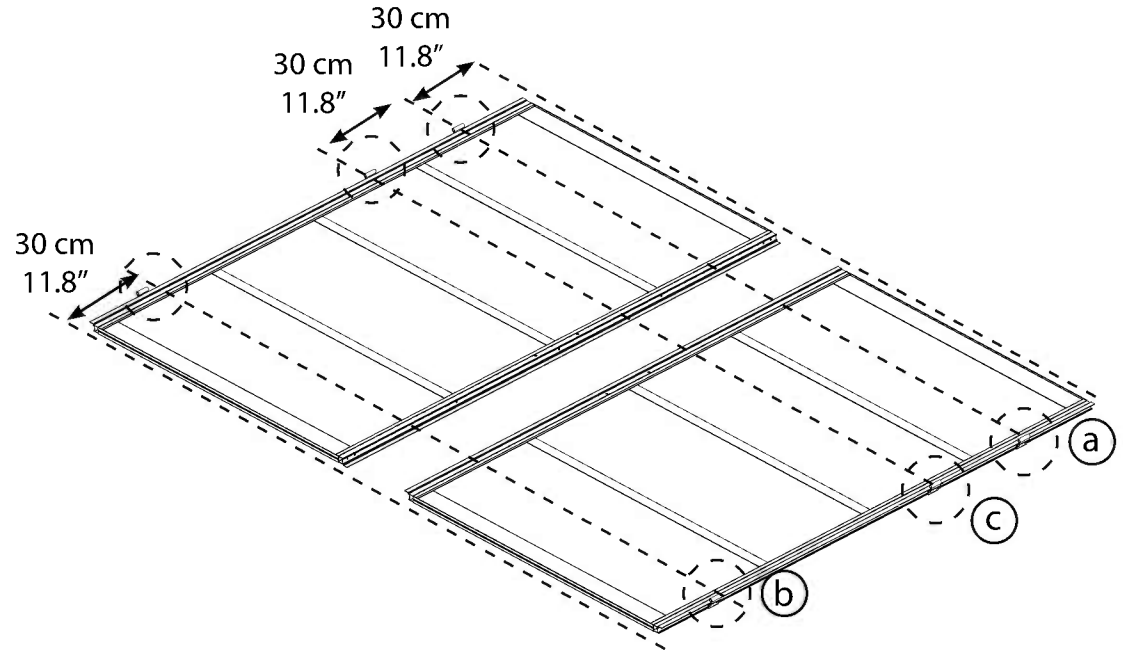
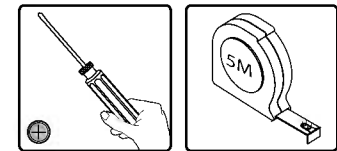
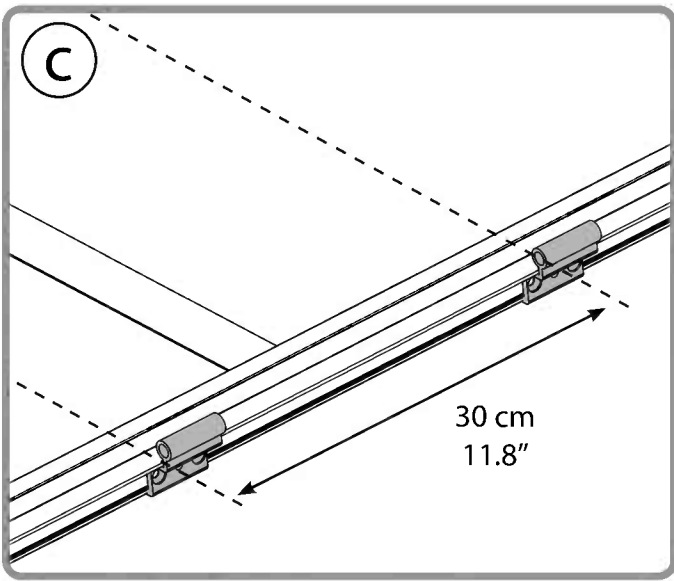
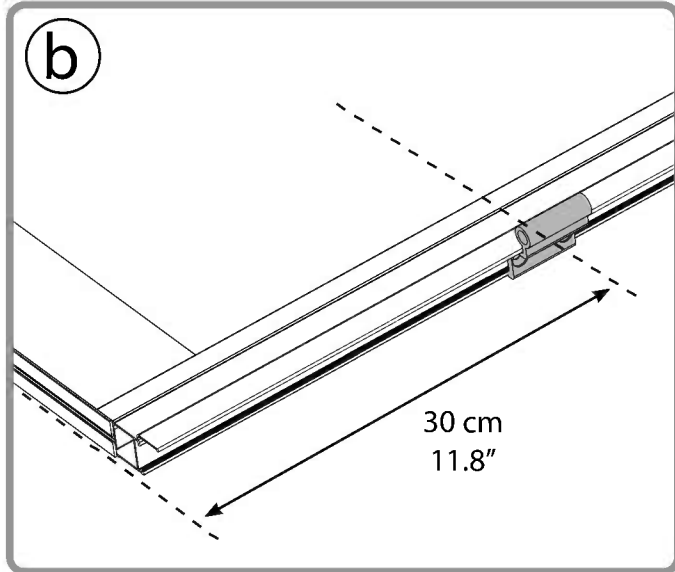
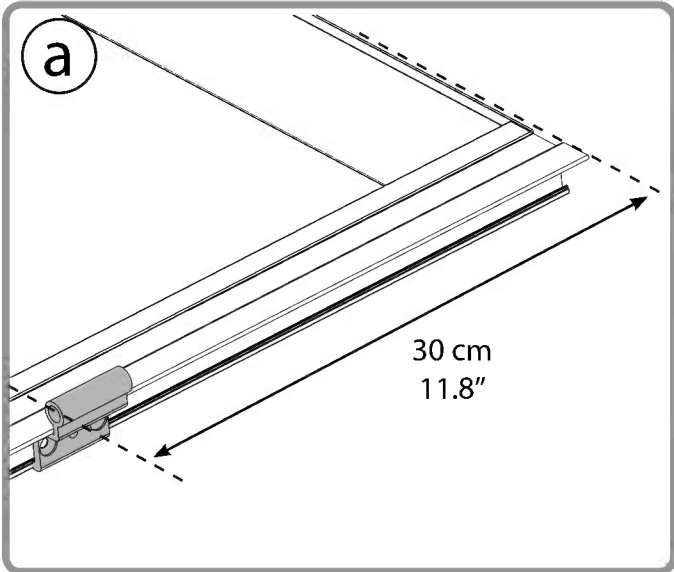

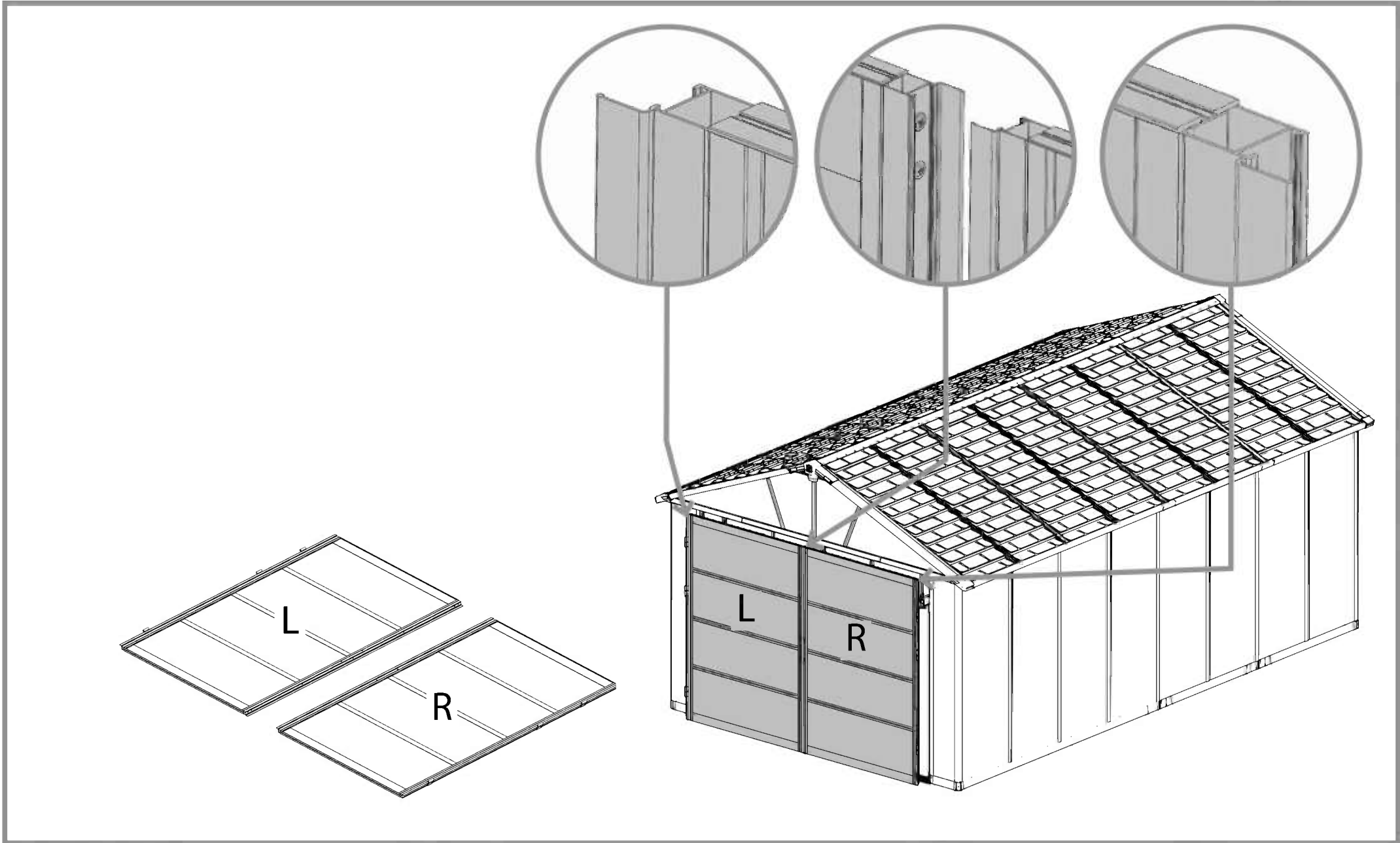

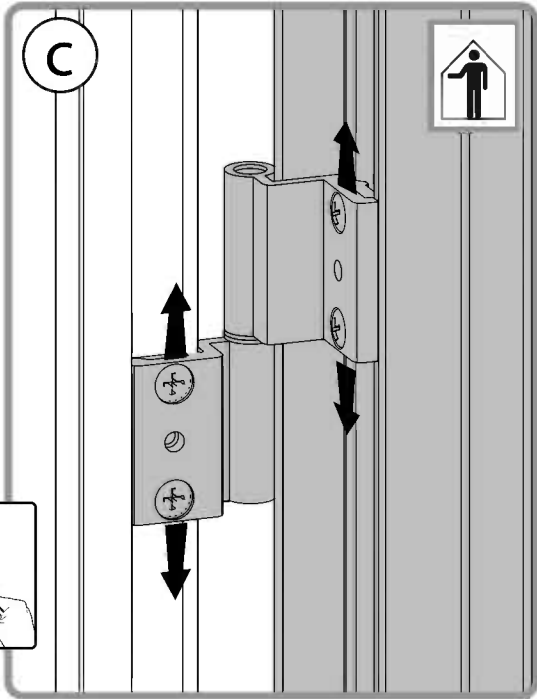
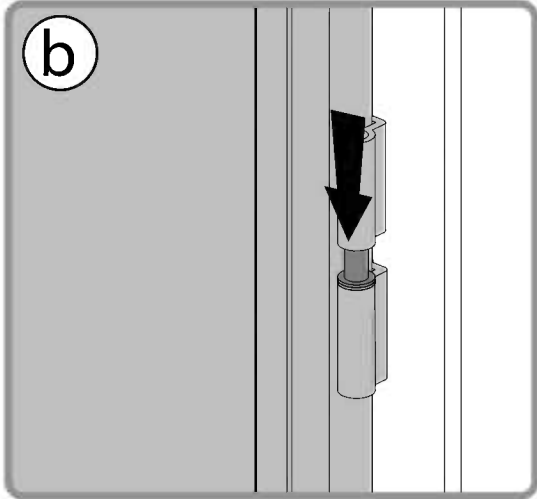
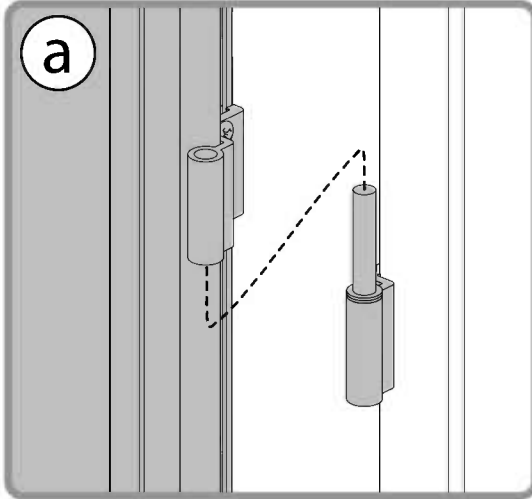
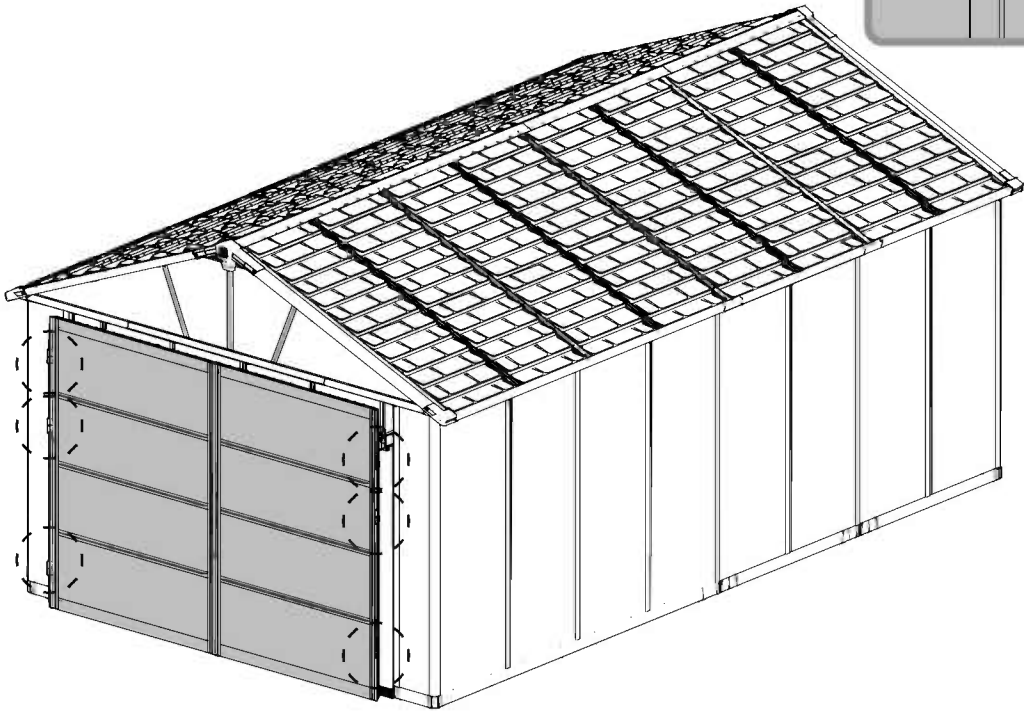

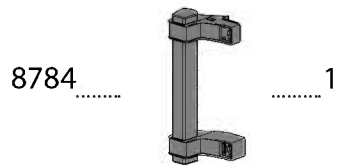

8784 ..... 1

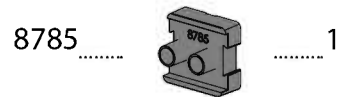

8785 ..... 1



8786 ..... 2

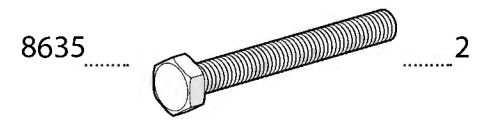

8635 ..... 2



466 ..... 2

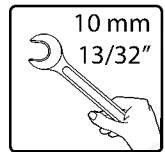

10 mm  
13/32"

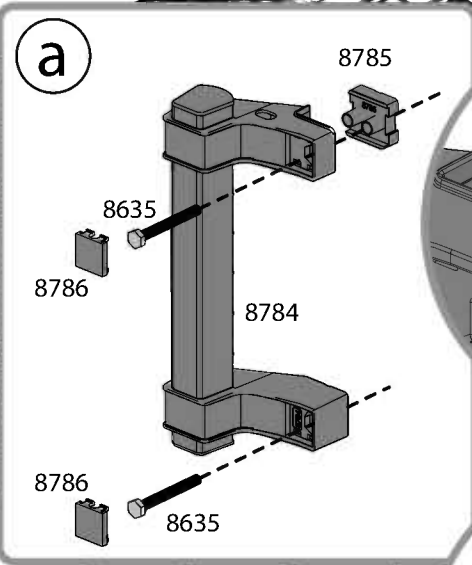
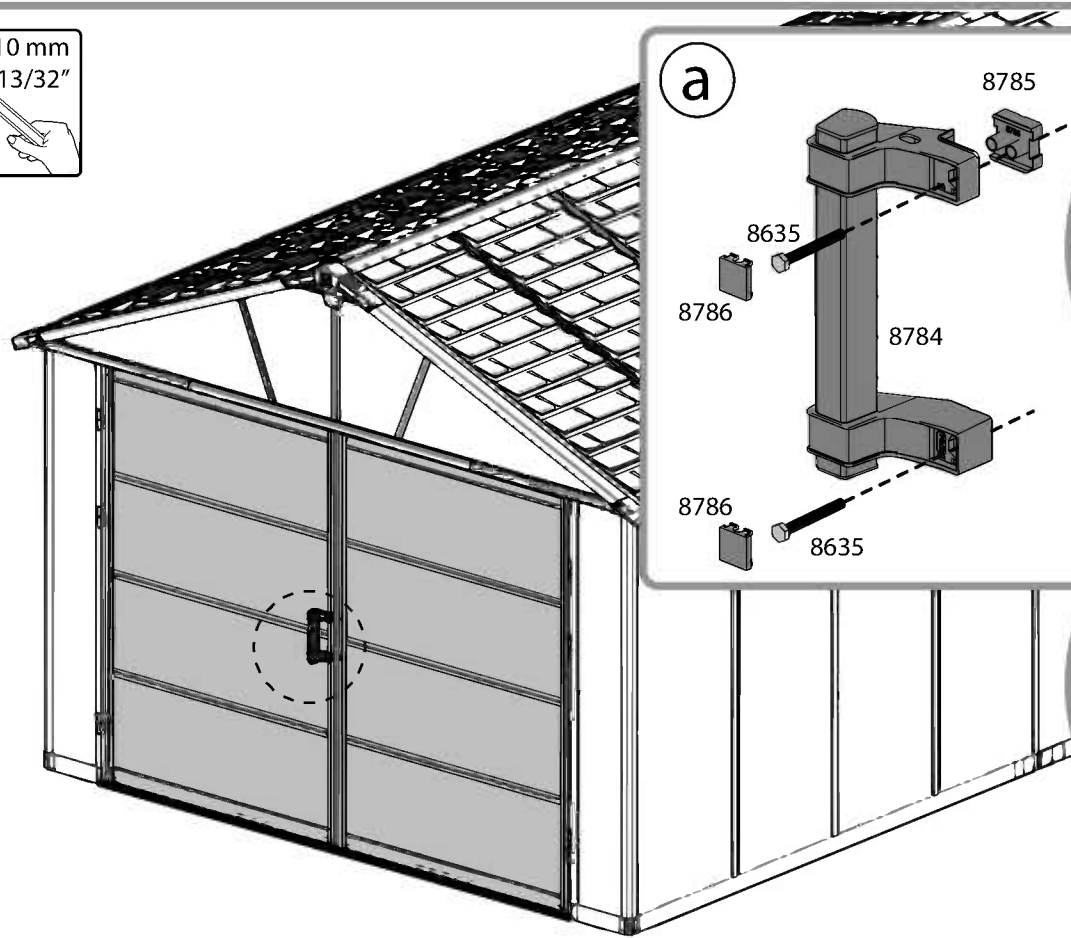

a

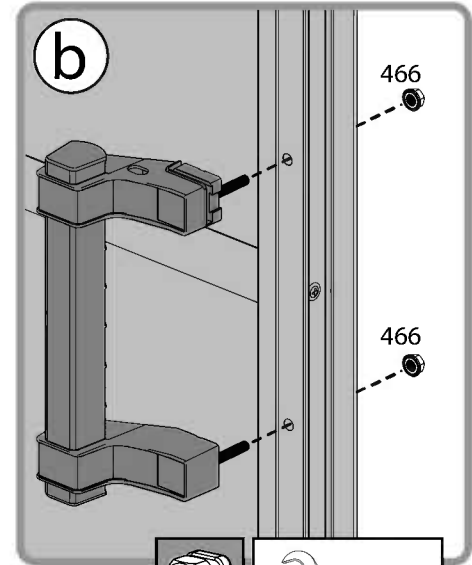
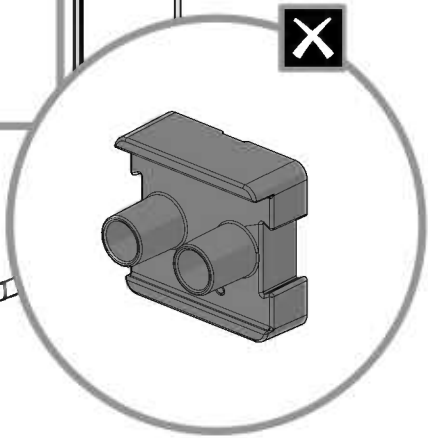
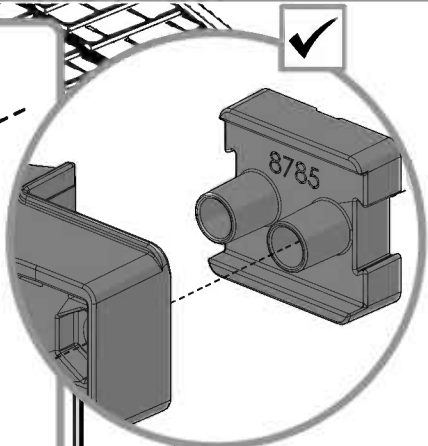

b

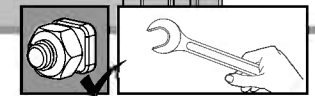



- 8783 ..... 1
- 8785 ..... 1
- 8786 ..... 2
- 8778 ..... 1
- 8779 ..... 1
- 8635 ..... 2
- 466 ..... 2

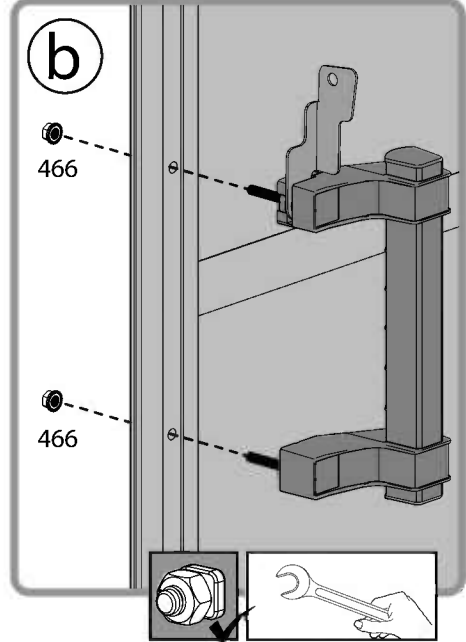
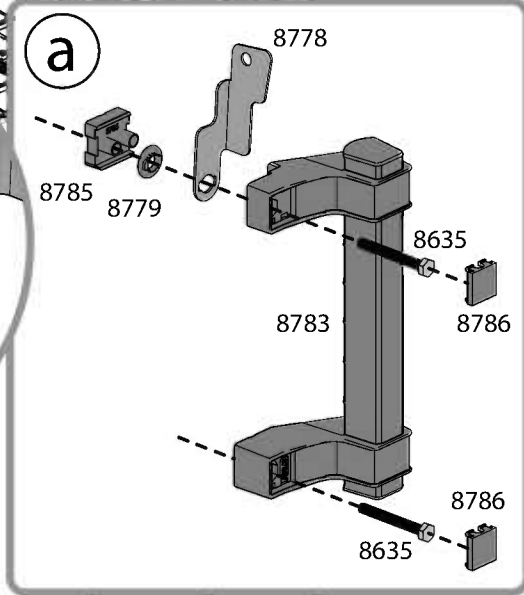
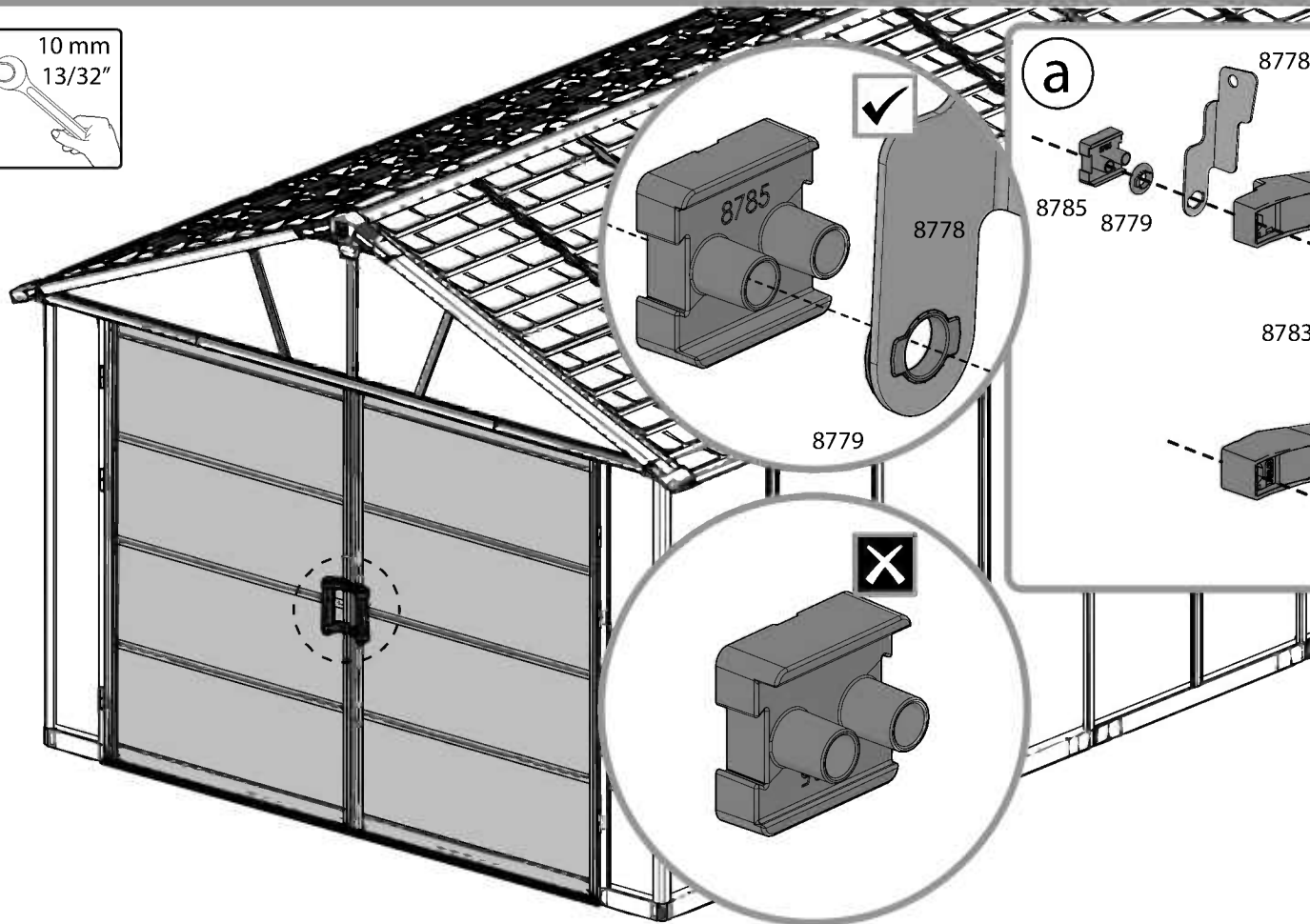

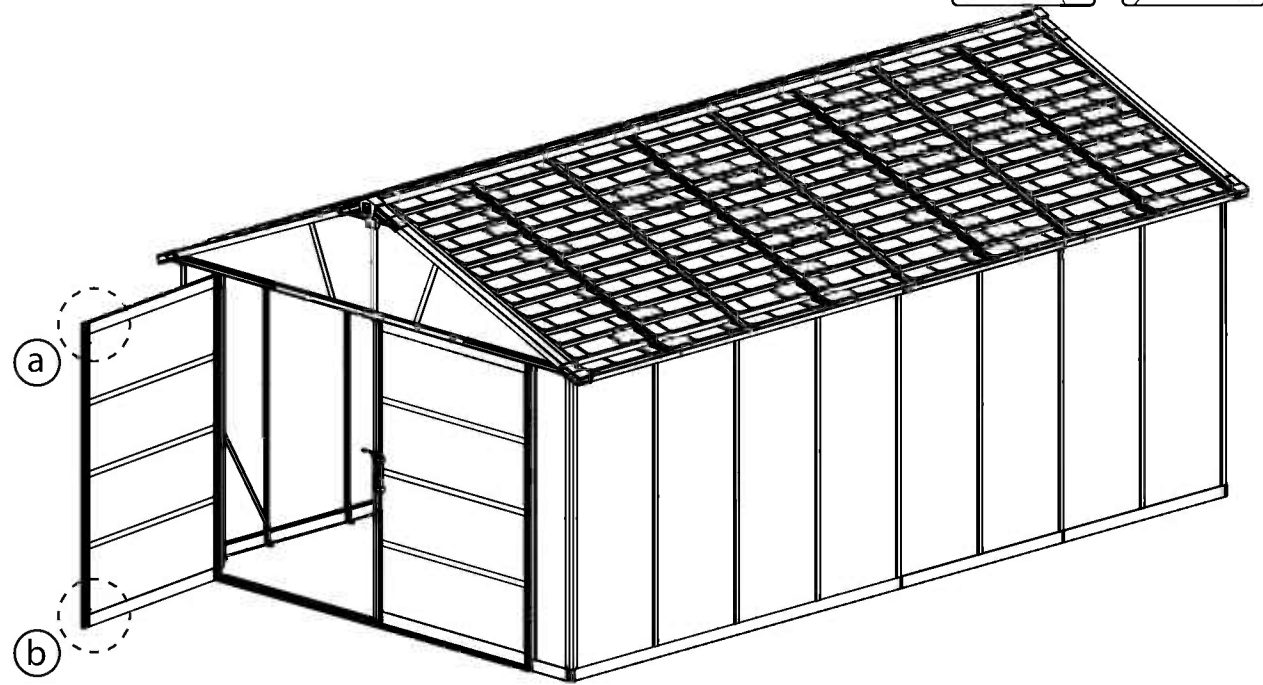
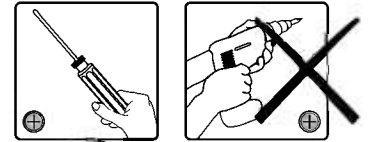
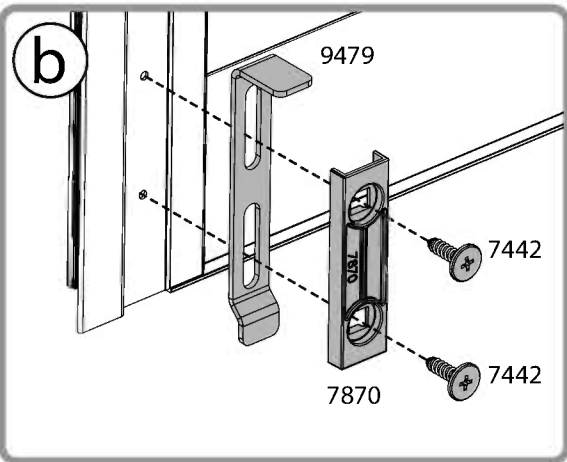
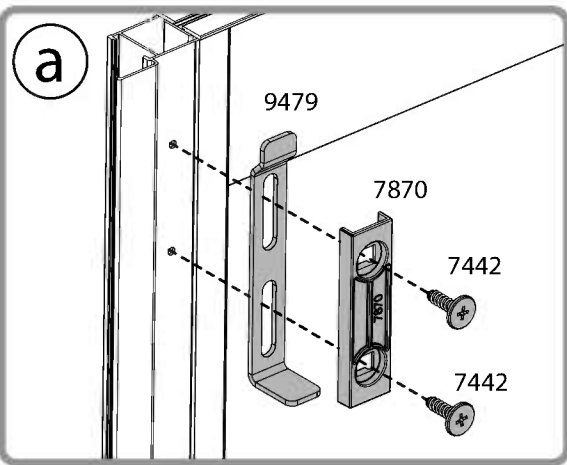
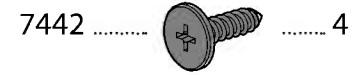
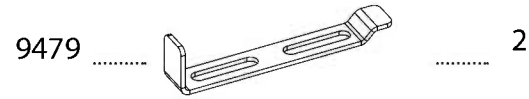
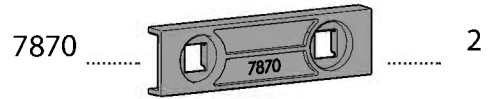

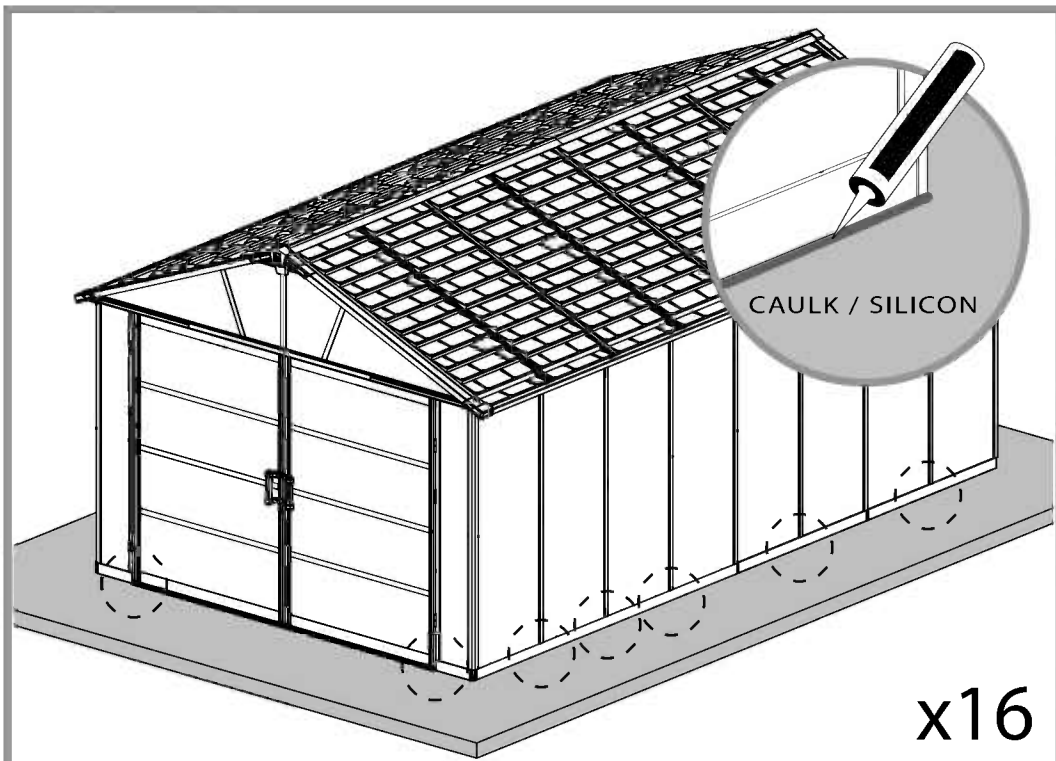

x16

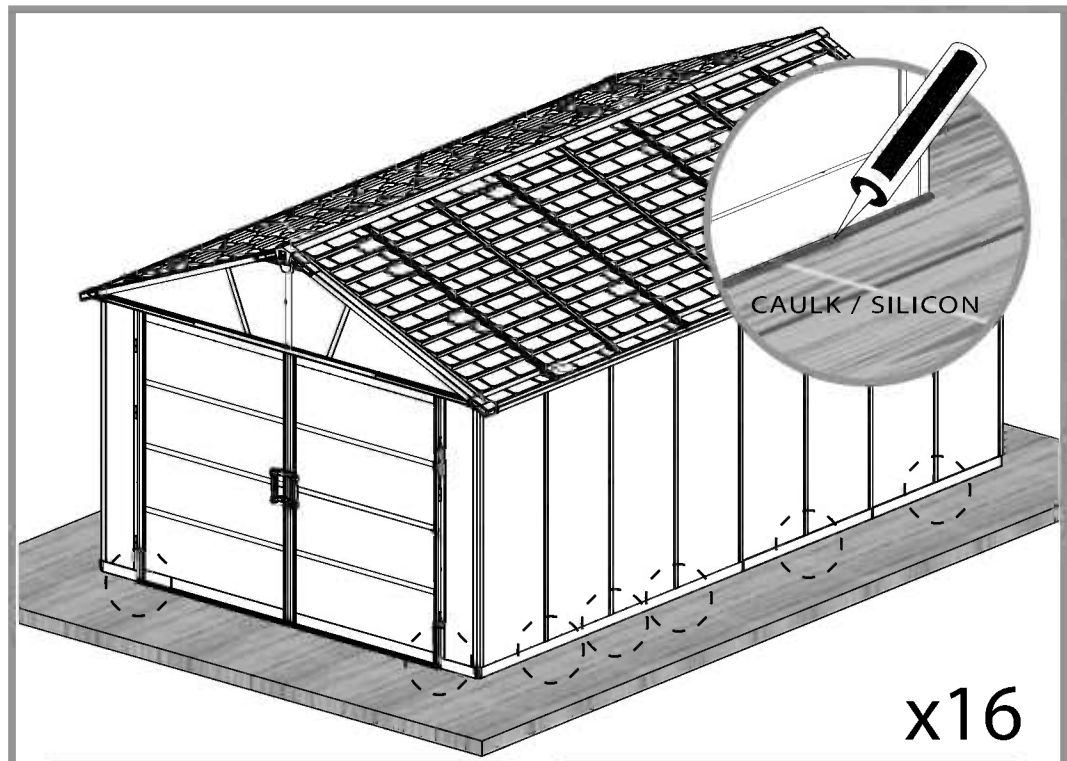

x16

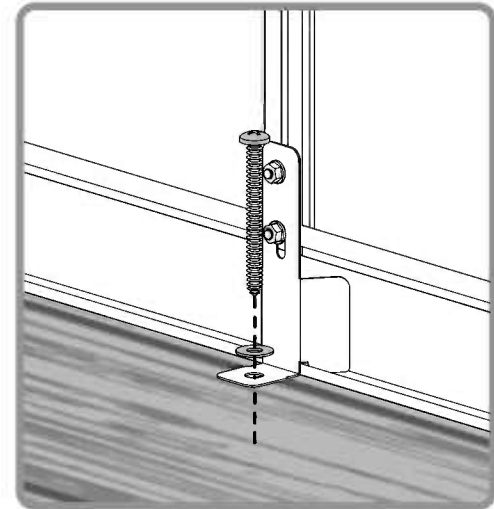
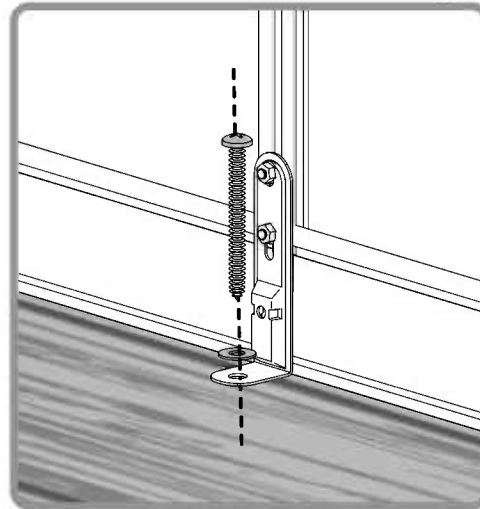
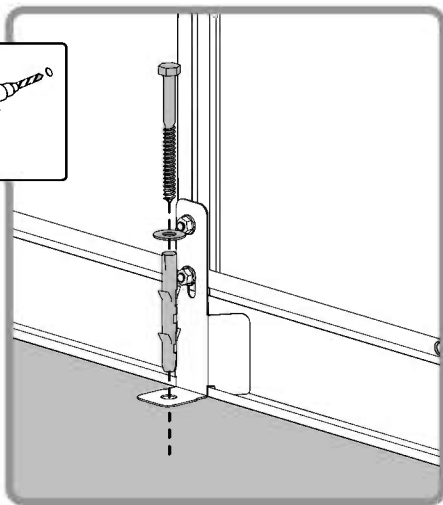
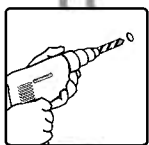
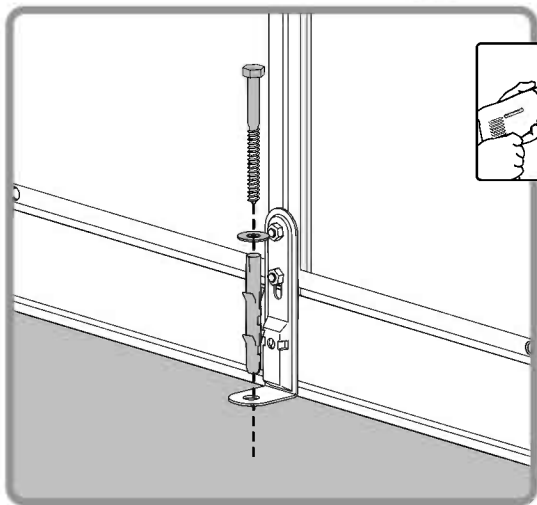



## PALRAM - CANOPIA | 15 years Limited Warranty

### Product Details: Canopia Garden Sheds

Palram Canopia Ltd (Company number: 512106824) whose registered office is at Teradion Industrial Park, M.P Misgav 20174, Israel ("Canopia") warrants that the product will be free from defects in material or workmanship for a period of 15 years from the original date of purchase subject to the definitions, terms and conditions contained in this warranty.

#### 1. Conditions

- This warranty shall be valid only if the product is installed, cleaned, handled and maintained in accordance with Canopia's written recommendations (Recommended User: Hobby Gardening).
- Without derogating from the above, damage caused by use of force, incorrect handling, inappropriate use, neglectful use or assembly or maintenance, accidents, impact from foreign objects, vandalism, pollutants, alteration, painting, connecting, gluing, sealing not in accordance with the user's manual, or damage resulting from cleaning with incompatible detergents and minor deviations of the product are not covered by this warranty.
- This warranty does not apply to damage resulting from "force majeure", which includes but is not limited to, hail, storm, tornado, hurricane, blizzard, flood, fire effects.
- This warranty is void if structural parts and components used are not compatible with Canopia's written recommendations.
- This Warranty applies only to the original purchaser of the product. It does not extend to any other purchaser or user of the product (including, but not limited to, any person who acquires the product from the original purchaser).
- Any other use for any other purpose is under user's sole responsibility. Canopia disclaims and assumes no liability for any use not recommended by this warranty.

#### 2. Claims and Notifications

- Every warranty claim must be notified in writing to Canopia within 30 days after the discovery of the defective product, enclosing the original sales receipt and this warranty.
- The claimant must allow Canopia to inspect the product involved and the installation site itself while the product is still in its original position and has not been removed or moved or altered in any way and/or return the product to Canopia for testing.
- Canopia reserves the right to investigate independently the cause of any failure.

#### 3. Compensation

- If a claim under this Warranty is properly notified and approved by Canopia, the purchaser, at Canopia's option, may either (a) purchase a replacement product or part/s; or (b) receive refund of the original product or part/s purchase price, all in accordance with the following schedule:

Period After Purchasing	Replacement Product or Part/s	Refund
From date of purchase up to end of 1 <sup>st</sup> year	Free of charge	100%
End of 1 <sup>st</sup> Year up to end of 2 <sup>nd</sup> year	purchaser will pay 10% of the original purchase price	93%
End of 2 <sup>nd</sup> year up to end of 3 <sup>rd</sup> year	purchaser will pay 16% of the original purchase price	86%
End of 3 <sup>rd</sup> year up to end of 4 <sup>th</sup> year	purchaser will pay 22% of the original purchase price	79%
End of 4 <sup>th</sup> year up to end of 5 <sup>th</sup> year	purchaser will pay 28% of the original purchase price	72%
End of 5 <sup>th</sup> year up to end of 6 <sup>th</sup> year	purchaser will pay 34% of the original purchase price	65%
End of 6 <sup>th</sup> year up to end of 7 <sup>th</sup> year	purchaser will pay 40% of the original purchase price	58%
End of 7 <sup>th</sup> year up to end of 8 <sup>th</sup> year	purchaser will pay 46% of the original purchase price	52%
End of 8 <sup>th</sup> year up to end of 9 <sup>th</sup> year	purchaser will pay 52% of the original purchase price	46%
End of 9 <sup>th</sup> year up to end of 10 <sup>th</sup> year	purchaser will pay 58% of the original purchase price	40%
End of 10 <sup>th</sup> year up to end of 11 <sup>th</sup> year	purchaser will pay 65% of the original purchase price	34%
End of 11 <sup>th</sup> year up to end of 12 <sup>th</sup> year	purchaser will pay 72% of the original purchase price	28%
End of 12 <sup>th</sup> year up to end of 13 <sup>th</sup> year	purchaser will pay 79% of the original purchase price	22%
End of 13 <sup>th</sup> year up to end of 14 <sup>th</sup> year	purchaser will pay 86% of the original purchase price	16%
End of 14 <sup>th</sup> year up to end of 15 <sup>th</sup> year	purchaser will pay 93% of the original purchase price	10%

- For avoidance of any doubt, calculation for determination regarding compensation for defective part/s, according to the schedule above, will be based on the contribution of the defective part to the original cost of the product. Canopia reserves the right to provide substitutions if the product or any part of it is unavailable or obsolete.
- This warranty does not cover any costs and expenses of removal and installation of the product or taxes or shipping cost or any other direct or indirect loss(es) which may result from the product failure.
- 4. General Conditions and Limitations**
- OTHER THAN HAS BEEN SPECIFICALLY STATED IN THIS WARRANTY, ALL OTHER WARRANTIES, WHETHER EXPRESS OR IMPLIED, INCLUDING ALL IMPLIED WARRANTIES OF MERCHANTABILITY OR FITNESS FOR A PARTICULAR PURPOSE ARE EXCLUDED SO FAR AS THE LAW PERMITS.
- EXCEPT WHERE WE HAVE SPECIFICALLY STATED IN THIS WARRANTY, CANOPIA SHALL NOT BE LIABLE FOR ANY LOSSES OR DAMAGES THE PURCHASER SUFFERS DIRECTLY, INDIRECTLY, OR AS A CONSEQUENCE OF USING, OR IN ANY OTHER WAY CONNECTED TO THE PRODUCT.
- IF CANOPIA IS PROHIBITED UNDER ANY APPLICABLE LAW FROM EXCLUDING THE IMPLIED WARRANTIES OF MERCHANTABILITY OR FITNESS FOR A PARTICULAR PURPOSE IN RELATION TO THE PRODUCT, THE DURATION OF ALL SUCH IMPLIED WARRANTIES IS EXPRESSLY LIMITED TO THE DURATION OF THIS WARRANTY OR, IF LONGER, THE MAXIMUM PERIOD REQUIRED BY APPLICABLE LAW.
- THE PURCHASER IS SOLELY RESPONSIBLE FOR DETERMINING WHETHER THE HANDLING, STORAGE, ASSEMBLY, INSTALLATION OR USE OF THE PRODUCT IS SAFE AND APPROPRIATE IN ANY LOCATION, FOR ANY GIVEN APPLICATION OR IN ANY GIVEN CIRCUMSTANCE. CANOPIA IS NOT RESPONSIBLE FOR ANY DAMAGES OR INJURY TO THE PURCHASER, ANY OTHER PERSON OR ANY PROPERTY RESULTING FROM THE IMPROPER HANDLING, STORAGE, INSTALLATION, ASSEMBLY OR USE OF THE PRODUCT OR THE FAILURE TO FOLLOW THE WRITTEN INSTRUCTIONS REGARDING THE HANDLING, STORAGE, INSTALLATION, ASSEMBLY AND USE OF THE PRODUCT.
- UNLESS OTHERWISE EXPRESSLY INDICATED BY CANOPIA, THE PRODUCT IS INTENDED FOR NORMAL RESIDENTIAL AND COMMERCIAL USE ONLY. CANOPIA IS NOT RESPONSIBLE FOR ANY LOSS, DAMAGE, COST OR EXPENSE RESULTING FROM ANY USE OF THE PRODUCT FOR ANY PURPOSE THAT IS NOT RECOMMENDED BY THE WRITTEN INSTRUCTIONS OR THAT IS NOT PERMITTED BY ANY APPLICABLE LEGISLATION OR OTHER CODES IN EFFECT IN THE LOCATION WHERE THE PURCHASER WILL USE THE PRODUCT.
- PLEASE NOTE:** ANCHORING THIS PRODUCT TO THE GROUND IS ESSENTIAL TO ITS STABILITY AND RIGIDITY. IT IS REQUIRED TO COMPLETE THIS STAGE IN ORDER FOR YOUR WARRANTY TO BE VALID.

## 15 Jahre beschränkte Garantie von PALRAM - CANOPIA

### Angaben zum Produkt: Canopia Gerätehäuser

Palram Canopia Ltd (Firmennummer: 512106824) mit Sitz in Teradion Industrial Park, M.P Misgav 20174, Israel („Canopia“) garantiert, dass das Produkt für einen Zeitraum von 15 Jahren ab dem Kaufdatum frei von Mängeln in Material und Verarbeitung wird, und den Definitionen, Begriffen und Bedingungen die in dieser Garantie enthalten sind unterliegt.

#### 1. Bedingungen

- Diese Garantie ist nur gültig, wenn das Produkt in Übereinstimmung mit den schriftlichen Empfehlungen von Canopia installiert, gereinigt, behandelt und gepflegt ist (Empfohlene Verwendung: Hobby Gärtnerei).
- Ohne Abweichung von oben genannten, Schäden, die durch Anwendung von Gewalt, unsachgemäße Behandlung, unsachgemäße Verwendung, nachlässige Nutzung, Montage oder Wartung, Unfälle, Auswirkungen von Fremdkörpern, Vandalismus, Verschmutzung, Veränderung, Malerei, Verbinden, Kleben und Dichten, nicht in Übereinstimmung mit der Bedienungsanleitung, verursacht werden, oder Schäden, die bei Reinigung mit inkompatiblen Reinigungsmitteln entstehen, so wie geringfügige Abweichungen des Produkts, werden durch diese Garantie nicht abgedeckt.
- Diese Garantie gilt nicht für Schäden, die durch „höhere Gewalt“ verursacht werden (beinhaltend aber nicht beschränkt auf: Hagel, Sturm, Tornado, Hurrikan, Schneesturm, Überschwemmungen, Feuer Auswirkungen).
- Diese Garantie erlischt, falls Bauteile und Komponente, die nicht mit den schriftlichen Empfehlungen von Canopia kompatibel sind, verwendet werden.
- Diese Garantie gilt ausschließlich für den ursprünglichen Käufer des Produkts. Sie erweitert sich nicht auf keine anderen Käufer oder Benutzer des Produkts (einschließlich, aber nicht beschränkt auf irgendeine andere Person die das Produkt von den ursprünglichen Käufer erwirbt).
- Jede andere Verwendung, für einen anderen Zweck liegt in der alleinigen Verantwortung des Benutzers.  
Canopia lehnt jede Haftung ab, die von dieser Garantie nicht gedeckt wird, bzw. übernimmt keine Haftung dafür.

#### 2. Ansprüche und Mitteilungen

- Jeder Gewährleistungsanspruch muss Canopia innerhalb von 30 Tagen nach Entdeckung des fehlerhaften Produkts schriftlich vorgelegt werden. Hierzu reichen Sie bitte auch den Original-Kaufbeleg und diese Garantie mit ein.
- Der Antragsteller muss Canopia erlauben den betroffenen Produkt und den Aufstellungsort selbst zu überprüfen, während das Produkt noch in seiner ursprünglichen Position ist und nicht entfernt oder verschoben oder in irgendeiner Weise verändert wurde, und/oder den Produkt an Canopia zum Testen zu senden.
- Canopia behält sich das Recht vor die Fehlerursachen unabhängig zu untersuchen.

#### 3. Entschädigung

- Ist ein Anspruch gemäß dieser Garantie ordnungsgemäß angemeldet und bei Canopia genehmigt worden, kann der Käufer, nach eigenem Ermessen von Canopia, entweder (a) ein Ersatzprodukt oder Teile erwerben; oder (b) eine Erstattung des ursprünglichen Produkt oder Teile Kaufpreises erhalten, alles in Übereinstimmung mit dem folgendem Schema:

Zeitraum nach Erwerbung	Ersatzprodukt bzw. Ersatzteile	Rückerstattung
Ab Kaufdatum bis zum Ende des 1. Jahr	Kostenlos	100%
Ende des 1. Jahr bis zum Ende des 2. Jahr	Käufer zahlt 10% des ursprünglichen Kaufpreises	93%
Ende des 2. Jahr bis zum Ende des 3. Jahr	Käufer zahlt 16% des ursprünglichen Kaufpreises	86%
Ende des 3. Jahr bis zum Ende des 4. Jahr	Käufer zahlt 22% des ursprünglichen Kaufpreises	79%
Ende des 4. Jahr bis zum Ende des 5. Jahr	Käufer zahlt 28% des ursprünglichen Kaufpreises	72%
Ende des 5. Jahr bis zum Ende des 6. Jahr	Käufer zahlt 34% des ursprünglichen Kaufpreises	65%
Ende des 6. Jahr bis zum Ende des 7. Jahr	Käufer zahlt 40% des ursprünglichen Kaufpreises	58%
Ende des 7. Jahr bis zum Ende des 8. Jahr	Käufer zahlt 46% des ursprünglichen Kaufpreises	52%
Ende des 8. Jahr bis zum Ende des 9. Jahr	Käufer zahlt 52% des ursprünglichen Kaufpreises	46%
Ende des 9. Jahr bis zum Ende des 10. Jahr	Käufer zahlt 58% des ursprünglichen Kaufpreises	40%
Ende des 10. Jahr bis zum Ende des 11. Jahr	Käufer zahlt 65% des ursprünglichen Kaufpreises	34%
Ende des 11. Jahr bis zum Ende des 12. Jahr	Käufer zahlt 72% des ursprünglichen Kaufpreises	28%
Ende des 12. Jahr bis zum Ende des 13. Jahr	Käufer zahlt 79% des ursprünglichen Kaufpreises	22%
Ende des 13. Jahr bis zum Ende des 14. Jahr	Käufer zahlt 86% des ursprünglichen Kaufpreises	16%
Ende des 14. Jahr bis zum Ende des 15. Jahr	Käufer zahlt 93% des ursprünglichen Kaufpreises	10%

- Um jegliche Zweifel auszuschließen, wird sich die Berechnung für die Bestimmung über Entschädigungen für defekte Teile, entsprechend der obigen Schema, auf dem Beitrag des defekten Teils an den ursprünglichen Kosten des Produktes beruhen. Canopia behält sich das Recht vor für ein Ersatz zu sorgen, falls der Produkt oder ein Teil davon nicht verfügbar oder veraltet ist.
- Diese Garantie erstreckt sich nicht auf Kosten und Ausgaben für Aus- und Einbau des Produkts oder Steuern oder Versandkosten oder sonstige direkte oder indirekte Verluste die sich von einem Produktfehler ergeben können.
- 4. Allgemeine Bedingungen und Einschränkungen**
- ANDERS ALS BESONDERS IN DIESER GARANTIE ANGEGBEN, ALLE ANDEREN GARANTIEEN, AUSDRÜCKLICH ODER IMPLIZIT, EINSCHLIESSLICH ALLER EINGESCHLOSSENEN GARANTIELEISTUNGEN DER MARKTGÄNGIGKEIT ODER EIGNUNG FÜR EINEN BESTIMMTEN ZWECK SIND SO WEIT DIES RECHTLICH MÖGLICH IST AUSGESCHLOSSEN.
- AUSSER ALS AUSDRÜCKLICH IN DIESER GARANTIE ANGEGBEN, HÄFTET CANOPIA NICHT FÜR IRGENDWELCHE VERLUSTE ODER SCHÄDEN DIE DER KÄUFER, DIREKT ODER INDIREKT ODER ALS FOLGE DER NUTZUNG ODER IN IRGENDWELCHEN ANDEREN MIT DEM PRODUKT VERBUNDENEN WEISE LEIDET.
- FALLS CANOPIA EIN AUSSCHLUSS DER STILLSCHWEIFENDEN GARANTIEEN DER MARKTGÄNGIGKEIT ODER EIGNUNG FÜR EINEN BESTIMMTEN ZWECK IN BEZUG AUF DAS PRODUKT NACH GELTENDEM RECHT NICHT GESTATTET IST, WIRD DIE DAUER ALLER SOLCHEN GARANTIEEN AUSDRÜCKLICH AUF DIE DAUER DIESER GARANTIE BESCHRÄNK, ODER FALLS LÄNGER, AUF DIE GESETZLICH VORGESCHRIEBENE HÖCHSTDAUER.
- DER KÄUFER IST ALLEIN DAFÜR VERANTWORTLICH FESTZUSTELLEN, OB DIE HANDHABUNG, LAGERUNG, MONTAGE, INSTALLATION ODER VERWENDUNG DES PRODUKTS AN BELIEBIGEN STANDORT UND FÜR JEDE GEGEBENE ANWENDUNG, ODER SITUATION, SICHER UND ANGEMESSEN IST. CANOPIA IST NICHT VERANTWORTLICH FÜR SCHÄDEN ODER VERLETZUNGEN DES KÄUFERS, ANDERER PERSONEN ODER DES EIGENTUMS, DIE IN FOLGE EINER UNSACHGEMÄSSEN HANDHABUNG, LAGERUNG, EINBAU, MONTAGE ODER NUTZUNG DES PRODUKTS ODER DURCH NICHTBEACHTUNG DER ANWEISUNGEN ZUR HANDHABUNG, LAGERUNG, EINBAU, MONTAGE UND NUTZUNG DES PRODUKTES ENTSTANDEN SIND.
- DIE WARE IST BESTIMMT AUSSCHLIESSLICH ZUR NORMALEN PERSÖNLICHEN UND KOMMERZIELLEN NUTZUNG, SOFERN NICHT AUSDRÜCKLICH ETWAS ANDERES DURCH CANOPIA VEREINBART WURDE. CANOPIA HÄFTET NICHT FÜR VERLUSTE, SCHÄDEN, KOSTEN ODER AUSGABEN, DIE RECHTS EINE NICHT VON DEN ANWEISUNGEN EMPFOHLENEN VERWENDUNG DES PRODUKTS ZU IRGENDINEM ZWECK ENTSTEHEN ODER DIE VON KEINEM GELTENDE RÜCKVORSCHRIFTEN ODER ANDEREN CODES ERLAUBT SIND DIE AN DEM ORT WO DER KÄUFER DEN PRODUKT BENUTZEN WIRD IN KRAFT SIND.
- DIE VERANKERUNG DIESES PRODUKTS IM UNTERGRUND IST WESENTLICH FÜR SEINE STABILITÄT UND FESTKEIT. SIE IST UNABLASLICH, UMN DIESEN ARBEITSSCHRITT ZU BEENDEN, DAMIT IHRE GARANTIE GÜLTIG BLEIBT.

Palram Canopia Ltd (Compagnie n° 512106824) dont le siège social est adressé au Parc Industriel Teradion, M.P. Misgav 2017400, Israël ("Canopia") garantit que le Produit n'a aucun défaut de matériel ou de manufacture pour une période de 15 ans à dater de la date d'acquisition, conformément aux définitions et conditions incluses dans cette garantie.

#### I. Garanties légales

##### 1. Garantie de défaut caché

- Conformément à l'article 1641 du Code Civil, l'acheteur est en droit de mettre en œuvre la garantie pour vice caché dans un délai de 2 ans au plus tard à compter de la découverte du défaut.
- Afin de bénéficier de cette garantie contre les défauts cachés, l'acheteur doit fournir (i) une preuve d'achat, (ii) la preuve que le défaut du produit était caché et existant au moment de l'achat du produit, et (iii) qu'un tel défaut rend le produit impropre à l'usage auquel il est destiné ou qu'il altère tellement l'utilisation du produit que l'acheteur ne l'aurait pas acheté, ou aurait seulement payé un prix moindre pour cela, aurait il/ elle connu de tels défauts.
- Conformément à l'article 1644 du Code civil, l'acheteur a le choix entre retourner le produit aux frais de Parlam et se faire rembourser le prix, ou garder le produit et se faire rembourser une partie du prix.

##### 2. Garantie de conformité

- En application des articles L.217-4 et suivants, du Code de la consommation, le produit doit, au moment de la livraison, être conforme au contrat. Toute réclamation relative à un défaut de conformité du produit doit être présentée dans un délai de deux ans au plus tard à compter de la livraison du produit.
- Afin de bénéficier de cette garantie de conformité, l'acheteur doit fournir une preuve d'achat.
- En application de l'article L. 217-9 du Code de la consommation, en cas de défaut de conformité du produit, l'acheteur peut choisir entre la réparation et le remplacement du produit.. Canopia peut néanmoins choisir de ne pas procéder conformément au choix de l'acheteur si ce choix entraîne un coût manifestement disproportionné par rapport à l'autre option, compte tenu de la valeur du produit ou de la gravité du défaut. Canopia procéderait alors avec l'option non choisie par l'acheteur, à moins que cela s'avère impossible.
- Si aucune réparation ou remplacement du produit n'est possible, l'acheteur peut retourner le produit et obtenir le remboursement du prix ou garder le produit et obtenir le remboursement d'une partie du prix. La même option s'appliquerait également (i) si la solution demandée, proposée ou convenue conformément à l'article 1.3 ne peut être mise en œuvre dans le mois suivant la demande de l'acheteur, ou (ii) si cette solution ne peut être mise en œuvre sans inconvénient majeur pour l'acheteur compte tenu de la nature du produit et de son usage prévu.

La vente ne sera toutefois pas annulée si le défaut de conformité est mineur.

Ces garanties légales s'appliquent quelle que soit la garantie commerciale définie ci-dessous.

#### II. Garantie commerciale

##### 1. Conditions

- Cette garantie ne sera valide que si le produit est installé, nettoyé, manipulé et entretenu conformément aux recommandations écrites de Canopia (Utilisation recommandée: Jardinage amateur).
- Sans déroger de ce qui est susdit, tout dommage causé par usage de la force, une mauvaise manipulation, un usage inapproprié, une utilisation, un montage ou une maintenance négligente, des accidents, un impact avec d'autres objets étrangers, du vandalisme, des polluants, un dégât, une peinture, connexion, collage, scellage qui n'est pas conforme avec le manuel de l'utilisateur ou tout dommage résultant de son nettoyage avec un détergent incompatible et les moindres déviations du produit ne sont pas couverts par cette garantie.
- Cette garantie ne s'applique pas aux dommages résultant d'un acte de force majeure, qui comprend mais n'est pas limité par la grêle, la tempête, une tornade, un ouragan, un blizzard, une inondation ou les effets d'un incendie.
- Cette garantie est nulle si des parties de la structure et des composants ne sont pas compatibles avec les recommandations écrites par Canopia.
- Cette garantie ne s'applique qu'à l'acheteur d'origine du produit. Elle ne s'étend pas à tout autre acquéreur ou utilisateur du produit (y compris mais non limité à toute personne qui acquerrait le produit de son acquéreur d'origine).
- Toute autre utilisation à d'autres fins est sous la seule responsabilité de l'utilisateur. Canopia décline et n'assume aucune responsabilité pour toute utilisation non recommandée par cette garantie.

##### 2. Réclamations et notifications

- Toute réclamation de garantie (autre que les garanties légales énoncées dans la section I. ci-dessus) doit être notifiée par écrit à Canopia dans les 30 jours suivant la découverte du produit défectueux, en joignant le reçu original et cette garantie.
- Le demandeur doit permettre à Canopia d'inspecter le produit impliqué et le site d'installation lorsque le produit est dans son emplacement d'origine et n'a pas été enlevé ou déplacé ni modifié de quelque façon et/ou envoyer le produit à Canopia pour vérification (les taxes et frais de ports n'étant pas à la charge du client).
- Canopia se réserve le droit d'enquêter indépendamment sur la cause de toute panne.

#### 3. Compensation

- Si une réclamation sous cette Garantie est convenablement notifiée et approuvée par Canopia, l'acheteur, au choix de Canopia, peut soit (a) acquérir un Produit de remplacement ou les pièces détachées nécessaires; ou (b) recevoir un remboursement du prix d'achat du Produit d'origine:

Période depuis l'achat	Produit de remplacement ou partie	Remboursement
Jusqu'à un an après l'achat	Gratuit	100%
De la fin de la 1 <sup>ère</sup> année à la fin de la 2 <sup>ème</sup>	L'acquéreur paiera 10% du prix d'achat d'origine	93%
De la fin de la 2 <sup>ème</sup> année à la fin de la 3 <sup>ème</sup>	L'acquéreur paiera 16% du prix d'achat d'origine	86%
De la fin de la 3 <sup>ème</sup> année à la fin de la 4 <sup>ème</sup>	L'acquéreur paiera 22% du prix d'achat d'origine	79%
De la fin de la 4 <sup>ème</sup> année à la fin de la 5 <sup>ème</sup>	L'acquéreur paiera 28% du prix d'achat d'origine	72%
De la fin de la 5 <sup>ème</sup> année à la fin de la 6 <sup>ème</sup>	L'acquéreur paiera 34% du prix d'achat d'origine	65%
De la fin de la 6 <sup>ème</sup> année à la fin de la 7 <sup>ème</sup>	L'acquéreur paiera 40% du prix d'achat d'origine	58%
De la fin de la 7 <sup>ème</sup> année à la fin de la 8 <sup>ème</sup>	L'acquéreur paiera 46% du prix d'achat d'origine	52%
De la fin de la 8 <sup>ème</sup> année à la fin de la 9 <sup>ème</sup>	L'acquéreur paiera 52% du prix d'achat d'origine	46%
De la fin de la 9 <sup>ème</sup> année à la fin de la 10 <sup>ème</sup>	L'acquéreur paiera 58% du prix d'achat d'origine	40%
De la fin de la 10 <sup>ème</sup> année à la fin de la 11 <sup>ème</sup>	L'acquéreur paiera 65% du prix d'achat d'origine	34%
De la fin de la 11 <sup>ème</sup> année à la fin de la 12 <sup>ème</sup>	L'acquéreur paiera 72% du prix d'achat d'origine	28%
De la fin de la 12 <sup>ème</sup> année à la fin de la 13 <sup>ème</sup>	L'acquéreur paiera 79% du prix d'achat d'origine	22%
De la fin de la 13 <sup>ème</sup> année à la fin de la 14 <sup>ème</sup>	L'acquéreur paiera 86% du prix d'achat d'origine	16%
De la fin de la 14 <sup>ème</sup> année à la fin de la 15 <sup>ème</sup>	L'acquéreur paiera 93% du prix d'achat d'origine	10%

#### 4. Conditions générales et limitations

- MIS A PART CE QUI A ETE SPECIFIQUEMENT INDIQUE DANS CETTE GARANTIE, TOUTES LES AUTRES GARANTIES, EXPRESSES OU SOUS-ENTENDUES, Y COMPRIS TOUTES LES GARANTIES SOUS-ENTENDUES DE VALEUR MARCHANDE OU D'ADAPTABILITE POUR UN OBJECTIF PARTICULIER SONT EXCLUES POUR AUTANT QUE LA LOI LE PERMET.
- MIS A PART LA OU NOUS L'AVONS SPECIFIQUEMENT DECLARE DANS CETTE GARANTIE, CANOPIA N'EST PAS RESPONSABLE DE TOUTE PERTE OU DOMMAGE DONT L'ACQUEUREUR SOUFFRIRAIT, DIRECTEMENT, INDIRECTEMENT OU EN CONSEQUENCE DE L'UTILISATION DU PRODUIT OU DE TOUTE AUTRE MANIERE LIEE AU PRODUIT.
- SI CANOPIA N'A PAS LE DROIT SELON LA MOINDRE LOI APPLICABLE D'EXCLURE LES GARANTIES SOUS-ENTENDUES DE VALEUR MARCHANDE OU D'ADAPTABILITE A UNE FIN SPECIFIQUE EN RAPPORT AVEC LE PRODUIT, LA DUREE D'UNE TELLE GARANTIE EST EXPRESSEMENT LIMITEE A CELLE DE CETTE GARANTIE OU, SI ELLE EST PLUS LONGUE, A LA PERIODE MAXIMALE EXIGEE PAR LA LOI.
- L'ACHETEUR EST LE SEUL RESPONSABLE DANS LA DETERMINATION SI LA MANIPULATION, LE STOCKAGE, LE MONTAGE, L'INSTALLATION OU L'UTILISATION DU PRODUIT EST SURE ET APPROPRIEE POUR TOUT ENDROIT, POUR TOUTE APPLICATION DONNEE OU DANS TOUTE CIRCONSTANCE DONNEE. CANOPIA N'EST PAS RESPONSABLE DE TOUT DOMMAGE OU BLESSURE CAUSE A L'ACHETEUR, TOUTE AUTRE PERSONNE OU BIEN RESULTANT D'UNE MANIPULATION, UN STOCKAGE, UNE INSTALLATION, UN MONTAGE OU UNE UTILISATION DU PRODUIT OU UN MANQUE A SUIVRE LES INSTRUCTIONS ECRITES CONCERNANT LA MANIPULATION, LE STOCKAGE, LE MONTAGE, L'INSTALLATION OU L'UTILISATION DU PRODUIT.
- SAUF DISPOSITION CONTRAIRE EXPRESSÉMENT INDIQUÉE PAR CANOPIA, LE PRODUIT EST DESTINÉ UNIQUEMENT À DES USAGES RÉSIDENTIELS ET COMMERCIAUX NORMAUX. CANOPIA N'EST PAS RESPONSABLE DE TOUTE PERTE, DOMMAGE, FRAIS OU DEPENSE RESULTANT D'UNE UTILISATION DU PRODUIT POUR TOUTE FIN QUI N'EST PAS RECOMMANDEE PAR LES INSTRUCTIONS ECRITES OU QUI N'EST PAS PERMISE PAR LA MOINDRE LOI OU AUTRES CODES APPLICABLES DANS L'ENDROIT OU L'ACQUEUREUR UTILISERAIT LE PRODUIT.
- CETTE ETAPE D'ANCRAGE DU PRODUIT AU SOL EST ESSENTIELLE A SA STABILITE ET A SA RIGIDITE, ELLE EST DE PLUS NECESSAIRE POUR ASSURER LA VALIDITE DE VOTRE GARANTIE..

## אחריות מוגבלת ל-15 שנים של PALRAM - CANOPIA

**מוצר: מחסני גינה CANOPIA**

Palram Canopia Ltd (פ. 512106824), אשר משרדה נמצאים בפארק תעשיות תרדיון, ד.ג. משגב 2017400, ישראל ("Canopia"), תחא אחראית לטיפול בפגמים בלתי צפויים שמקורם בחומרים ובטיב העבודה למשך 15 שנים מתאריך הרכישה המקורי, בכפוף להגדרות, התנאים וההתניות הכלולים בכתב אחריות זה. Canopia שמורת לעצמה הזכות לשנות את מגוון המוצרים שברשותה, או חלקי החילוף שלהם, או להוציאם מהמגוון.

- הנאים**
- 1.1 אחריות זו תחא תקפה רק אם המוצר הותקן, מנוקה, מטופל ומתוחזק בהתאם להמלצות הכתובות של Canopia (שימוש מומלץ: חממת גיוון).
- 1.2 בדי לפגוע לא להפחית מערך האמור לעיל, נזק אשר נגרם עקב שימוש בכות, טיפול שגוי, שימוש שאינו הולם, שימוש, הרכבה, או תחזוקה רשלניים, תאונות, מכה מעצמים זרים, נדליונם, חומרים מזדממים, שינוי, צביעה, חיבור, הדבקה או נזק אשר נגרם עקב ניקוי באמצעות חומרי ניקוי שאינם מתאימים, וסתיית קטנות במוצר, אינם מכוסים על ידי כתב אחריות זה.

**למען הסר ספק, האחריות כופפה לתנאים הבאים:**

- (1) הפגם לא נגרם כתוצאה משימוש שאינו הולם או משמוש, הרכבה או תחזוקה רשלניים, תאונות או מכה מעצמים זרים.
- (2) הפגם לא נגרם בודון או ברשלנות חמורה.
- (3) השימוש במוצר או בחלקיו היה סביר ורגיל ונעשה בהתאם להוראות Canopia.
- (4) הפגם אינו נובע מבלאי סביר עקב שימוש רגיל.
- (5) לא נעשה ניסיון לחילוק הפגם על ידי גורם כלשהו מלבד נציג מוסמך מטעם Canopia או בהתאם להוראות Canopia.
- (6) הפגם לא נגרם כתוצאה משימוש בחומר לא מתאים, חומר מזדם, צביעה, הדבקה, נזק שנגרם כתוצאה משימוש בחומרי ניקוי שאינם מתאימים.
- (7) במוצרים להרכבה עצמית - הפגם לא נגרם במהלך הרכבת המוצר או כתוצאה מהרכבה לא נכונה.
- (8) הפגם לא נגרם במהלך הובלה עצמית של המוצר.
- (9) הפגם לא נגרם כתוצאה משינוי שנעשה במוצר.
- (10) הפגם אינו נגרם כתוצאה ממוח עליון לרבות אך לא רק סופות רוח, ברד, טורנדו, הוריקן, סופות שלג, הצפות, שריפות ונזקי שמש
- 1.3 אחריות זו בלתי אם רכיבים וחלקים קונסטרוקטיביים כלשהם שנעשה בהם שימוש אינם תואמים את ההמלצות הכתובות של Canopia.
- 1.4 כתב אחריות זה חל רק על הקונה המקורי של המוצר. הוא אינו עובר אל קונים או משתמשים אחרים במוצר (לרבות אך לא מוגבל לכל אדם אשר רוכש או מקבל את המוצר לרשותו מידי הקונה המקורי).
- 1.5 Canopia אינה אחראית לכל שימוש אחר שאינו מוגדר באחריות זו.

### 2. תביעות והודעות

יש להודיע בכתב על כל פנייה במסגרת כתב האחריות תוך 30 יום ממועד גילוי הפגם במוצר, בצירוף קבלת הרכישה המקורית וכתב אחריות זה ("להלן: "פנייה במסגרת כתב האחריות").

החובע חייב לאפשר לCanopia לבדוק את המוצר האמור אתר ואת ההתקנה עצמו כאשר המוצר נמצא עדיין במיקומו המקורי, ולא הוסר או הוזז ממקומו או שונה באופן כלשהו, ו/או להחזיר את המוצר לCanopia לצורך בדיקתו.

Canopia שמורת לעצמה את הזכות לחקור באופן עצמאי את הגוים לכל כשל או תקלה.

### 3. תשלום

אם פנייה במסגרת כתב האחריות נמסרה כהלכה לCanopia ואושרה על ידה, הקונה רשאי, לפי בחירת Canopia, (א) לרכוש מוצר חלופי או חלפים, או (ב) לקבל החדר תמורת המוצר המקורי או מחיר הקנייה של החלפים, וכל זאת בהתאם לאמור בפירוט הבא:

תקופה שלאחר הרכישה	מוצר חלופי או חלפים	החזר
מתאריך הרכישה ועד לסוף השנה הראשונה	בחינם (ללא עלות)	100%
מסוף השנה הראשונה ועד לסוף השנה השנייה	הקונה ישלם 10% ממחיר הרכישה המקורי	93%
מסוף השנה השנייה ועד לסוף השנה השלישית	הקונה ישלם 16% ממחיר הרכישה המקורי	86%
מסוף השנה השלישית ועד לסוף השנה הרביעית	הקונה ישלם 22% ממחיר הרכישה המקורי	79%
מסוף השנה הרביעית ועד לסוף השנה החמישית	הקונה ישלם 28% ממחיר הרכישה המקורי	72%
מסוף השנה החמישית ועד לסוף השנה השישית	הקונה ישלם 34% ממחיר הרכישה המקורי	65%
מסוף השנה השישית ועד לסוף השנה השביעית	הקונה ישלם 40% ממחיר הרכישה המקורי	58%
מסוף השנה השביעית ועד לסוף השנה השמינית	הקונה ישלם 46% ממחיר הרכישה המקורי	52%
מסוף השנה השמינית ועד לסוף השנה החשיעית	הקונה ישלם 52% ממחיר הרכישה המקורי	46%
מסוף השנה החשיעית ועד לסוף השנה העשירית	הקונה ישלם 58% ממחיר הרכישה המקורי	40%
מסוף השנה העשירית ועד לסוף השנה האחת עשרה	הקונה ישלם 65% ממחיר הרכישה המקורי	34%
מסוף השנה האחת עשרה ועד לסוף השנה השתיים עשרה	הקונה ישלם 72% ממחיר הרכישה המקורי	28%
מסוף השנה השתיים עשרה ועד לסוף השנה השלוש עשרה	הקונה ישלם 79% ממחיר הרכישה המקורי	22%
מסוף השנה השלושה עשרה ועד לסוף השנה הארבע עשרה	הקונה ישלם 86% ממחיר הרכישה המקורי	16%
מסוף השנה הארבע עשרה ועד לסוף השנה החמש עשרה	הקונה ישלם 93% ממחיר הרכישה המקורי	10%

למען הסר ספק, החישוב לקביעת התשלום המגיע לקונה תמורת חלקים פגומים, בהתאם לפירוט שצוין לעיל, יתבסס על חלקו של החלק הפגום בעלות המקורית של המוצר. Canopia שמורת לעצמה את הזכות לספק תחלפים במקרה שהמוצר או חלק כלשהו ממנו אינם זמינים או מיושנים.

3.3 כתב אחריות זה אינו מכסה עלויות הוצאות כלשהן עקב הסרה והתקנה של המוצר, וכן מסים ועלויות משלוח או כל הפסד ישיר או נזקף אשר עשוי להיגרם עקב הפסל או התקלה במוצר.

### 4. תנאים כלליים והגבלות

4.1 פרט למה שצוין במפורש בכתב אחריות זה, כל ההתחייבויות האחרות, בין אם מפורשות ובין אם משתמעות, לרבות כל ההתחייבויות המשתמעות לסחירת או התאמה לשימוש ספציפי, אינן כלולות בכתב אחריות זה ככל שמותר החוק.

4.2 למעט היכן שציינו זאת במפורש בכתב אחריות זה, CANOPIA לא חישא באחריות להפסדים או נזקים כלשהם לקונה, בין אם ישירים, בין אם עקיפים ובין אם כתוצאה מהשימוש במוצר, ובכל אופן אחר שקשור למוצר.

4.3 אכל החוק ההל אוסר על CANOPIA לשלול התחייבות משתמעת לסחירת או התאמה לשימוש ספציפי הנוגעות למוצר, משך ההתחייבות. משתמעת האמורה יוגבל באופן מפורש למשך האחריות המוגדר בכתב אחריות זה, או זה הוא ארוך יותר, למשך התקופה המרבית הנדרשת על פי חוק.

4.4 הקונה נושא באחריות בלעדית לביצוע הטיפול, האחסון, ההרכבה, ההתקנה והשימוש במוצר באופן בטוח והולם בכל מיקום שהוא, עבור כל יישום תחון ובכל נסיבה נתונה. CANOPIA אינה נושאת באחריות לנזקים כלשהם או פגיעה כלשהי לקונה, לאדם או לרכשו ולרכשו כלשהו, אשר נגרמו עקב טיפול, אחסון, התקנה, הרכבה ושימוש שאינם הולמים, וכן מאי ביצוע ההוראות הכתובות בנוגע לטיפול, אחסון, תחיקה, הרכבה ושימוש במוצר.

4.5 אלא אם כן צוין אחרת באופן מפורש על ידי CANOPIA, המוצר מיועד לשימוש ביתי ומתסחרי רגיל בלבד. CANOPIA לא חישא באחריות להפסד, נזק, עלות או הוצאה כלשהם אשר נגרמו עקב שימוש כלשהו במוצר למטרה שאינה מומלצת על ידי ההוראות הכתובות, או למטרה שאסורה על פי חוק או דין ישים כלשהו אשר תקפים במיקום בו הקונה מתכוון להשתמש במוצר.

4.6 עיגון המוצר לקרקע חיוני ליציבות ועמידותו. תוקף אחריות המוצר תלוי בהשלמת העיגון לקרקע.

## Garantía limitada de 15 años de PALRAM - CANOPIA

Angaben zum Produkt: Canopia Cobertizo

Palram Canopia Ltd (Número de la compañía: 512106824) cuya oficina registrada se encuentra en Teradion Industrial Park, M.P Misgav 20174, Israel (“Canopia”) garantiza que el Producto no tendrá defectos de material o de fabricación durante un periodo de 15 años desde la fecha de compra original sujeto a las definiciones, términos y condiciones contenidos en esta garantía.

- Condiciones**
- 1.1 Esta garantía solo será válida si el Producto es instalado, limpiado, manipulado y mantenido de acuerdo a las recomendaciones por escrito de Canopia (Uso recomendado: jardinería privada).
- 1.2 Sin derogar lo anterior, los daños causados por el uso de la fuerza, manipulación incorrecta, uso inapropiado, uso o montaje o mantenimiento negligentes, accidentes, impacto de objetos extraños, vandalismo, contaminantes, alteración, pintado, conexión, pegado, sellado no de acuerdo al manual del usuario, o daños resultantes de la limpieza con detergentes incompatibles y desviaciones menores del Producto no están cubiertos por esta garantía.
- 1.3 Esta garantía no se aplica a daños resultantes de “fuerza mayor”, que incluye entre otros, granizo, tormenta, tornado, huracán, ventisca, inundación, efectos del fuego.
- 1.4 Esta garantía es nula si los componentes o piezas estructurales utilizados no son compatibles con las recomendaciones escritas de Canopia.
- 1.5 Esta garantía se aplica solamente al comprador normal del Producto. No se extiende a cualquier otro comprador o usuario del Producto (incluyendo, entre otros, cualquier persona que adquiera el Producto desde el comprador original).
- 1.6 La utilización para cualquier otro fin es de la exclusiva responsabilidad del usuario. Canopia rechaza y no asume ninguna responsabilidad por cualquier uso que no esté contemplado en esta garantía.

### 2. Reclamaciones y notificaciones

2.1 Toda reclamación de la garantía debe ser notificada por escrito a Canopia lo antes que sea posible razonablemente después de descubrir el Producto defectuoso, adjuntando el tique de venta original y esta garantía.

2.2 El reclamante debe permitir a Canopia inspeccionar el Producto pertinente y el sitio de la instalación en sí mismo mientras el Producto está todavía en su posición original y no se ha retirado ni movido o alterado de ningún modo y/o devolver el Producto a Canopia para evaluarlo.

2.3 Canopia se reserva el derecho a investigar la causa de cualquier fallo de forma independiente.

### 3. Compensación

3.1 Si una reclamación bajo esta Garantía se notifica apropiadamente y es aprobada por Canopia, el comprador, según considere Canopia, puede o bien (a) comprar un Producto o piezas/s de recambio; o (b) recibir el reembolso del precio de compra del Producto o la pieza o piezas, todo de acuerdo al siguiente calendario:

El periodo tras la compra	Reembolso del Producto o Pieza /s	Recambio Según
Desde la fecha de compra hasta el final del primer año	Sin costes	100 <span> </span> %
Fin del 1.er año hasta el final del 2.º año	El comprador pagará el 10 <span> </span> % del precio original de compra	93 <span> </span> %
Fin del 2.º año hasta el final del 3.er año	El comprador pagará el 16 <span> </span> % del precio original de compra	86 <span> </span> %
Fin del 3.er año hasta el final del 4.º año	El comprador pagará el 22 <span> </span> % del precio original de compra	79 <span> </span> %
Fin del 4.º año hasta el final del 5.º año	El comprador pagará el 28 <span> </span> % del precio original de compra	72 <span> </span> %
Fin del 5.º año hasta el final del 6.º año	El comprador pagará el 34 <span> </span> % del precio original de compra	65 <span> </span> %
Fin del 6.º año hasta el final del 7.º año	El comprador pagará el 40 <span> </span> % del precio original de compra	58 <span> </span> %
Fin del 7.º año hasta el final del 8.º año	El comprador pagará el 46 <span> </span> % del precio original de compra	52 <span> </span> %
Fin del 8.º año hasta el final del 9.º año	El comprador pagará el 52 <span> </span> % del precio original de compra	46 <span> </span> %
Fin del 9.º año hasta el final del 10.º año	El comprador pagará el 58 <span> </span> % del precio original de compra	40 <span> </span> %
Fin del 10.º año hasta el final del 11.º año	El comprador pagará el 65 <span> </span> % del precio original de compra	34 <span> </span> %
Fin del 11.º año hasta el final del 12.º año	El comprador pagará el 72 <span> </span> % del precio original de compra	28 <span> </span> %
Fin del 12.º año hasta el final del 13.º año	El comprador pagará el 79 <span> </span> % del precio original de compra	22 <span> </span> %
Fin del 13.º año hasta el final del 14.º año	El comprador pagará el 86 <span> </span> % del precio original de compra	16 <span> </span> %
Fin del 14.º año hasta el final del 15.º año	El comprador pagará el 93 <span> </span> % del precio original de compra	10 <span> </span> %

3.2 Para evitar cualquier duda, el cálculo de la determinación de la compensación por piezas/s defectuosas, según el calendario de arriba, se basará en la contribución de la pieza defectuosa al coste original del Producto. Canopia se reserva el derecho de proporcionar sustituciones si el Producto o cualquier pieza del mismo no está disponible o es obsoleta.

3.3 Esta garantía no cubre ningún coste ni gasto de la retirada e instalación del Producto o impuestos o gastos de envío ni cualquier otra pérdida/s directa o indirecta que pueda resultar del defecto del Producto.

### 4. Condiciones generales y limitaciones

4.1 APARTE DE LO QUE SE HA AFIRMADO ESPECÍFICAMENTE EN ESTA GARANTÍA, TODAS LAS DEMÁS GARANTÍAS, TANTO EXPRESAS COMO IMPLÍCITAS, INCLUYENDO TODAS LAS GARANTÍAS IMPLÍCITAS DE COMERCIALIZABILIDAD O IDONEIDAD PARA UN PROPÓSITO EN PARTICULAR SE EXCLUYEN EN LA EXTENSIÓN EN QUE LO PERMITA LA LEY.

4.2 EXCEPTO DONDE LO HAYAMOS DECLARADO ESPECÍFICAMENTE EN ESTA GARANTÍA, CANOPIA NO SERÁ RESPONSABLE DE CUALQUIER PÉRDIDA O DAÑOS QUE SUFRA EL COMPRADOR DIRECTAMENTE, INDIRECTAMENTE O COMO CONSECUENCIA DE UTILIZAR EL PRODUCTO O EN CONEXIÓN DE CUALQUIER MODO CON EL MISMO.

4.3 SI SE PROHIBE A CANOPIA, BAJO CUALQUIER LEY APLICABLE, EXCLUIR LAS GARANTÍAS IMPLÍCITAS DE COMERCIALIZABILIDAD O IDONEIDAD PARA UN PROPÓSITO EN PARTICULAR CON RELACIÓN AL PRODUCTO, LA DURACIÓN DE DICHAS GARANTÍAS IMPLÍCITAS SE LIMITA EXPRESAMENTE A LA DURACIÓN DE ESTA GARANTÍA, O SI ES MAS TIEMPO, EL PERIODO MÁXIMO REQUERIDO POR LA LEY APLICABLE.

4.4 EL COMPRADOR ES RESPONSABLE ÚNICAMENTE DE DETERMINAR SI LA MANIPULACIÓN, ALMACENAMIENTO, MONTAJE, INSTALACIÓN O USO DEL PRODUCTO ES SEGURO Y APROPIADO EN CUALQUIER UBICACIÓN, PARA CUALQUIER APLICACIÓN DADA O EN CUALQUIER CIRCUNSTANCIA DADA. CANOPIA NO ES RESPONSABLE POR CUALQUIER DAÑO O LESIÓN DEL COMPRADOR, CUALQUIER OTRA PERSONA O CUALQUIER PROPIEDAD QUE RESULTE DE LA MANIPULACIÓN, ALMACENAMIENTO, INSTALACIÓN, MONTAJE O USO INADECUADOS DEL PRODUCTO O NO SEGUIR LAS INSTRUCCIONES ESCRITAS ACERCA DE LA MANIPULACIÓN, ALMACENAMIENTO, INSTALACIÓN, MONTAJE Y USO DEL PRODUCTO.

4.5 A MENOS QUE SE INDIQUE EXPRESAMENTE LO CONTRARIO POR CANOPIA, EL PRODUCTO ESTÁ PREVISTO SOLO PARA USO RESIDENCIAL Y COMERCIAL. CANOPIA NO ES RESPONSABLE POR NINGUNA PÉRDIDA, DAÑO, COSTE O GASTO RESULTANTE DE CUALQUIER USO DEL PRODUCTO PARA CUALQUIER PROPÓSITO QUE NO ESTÉ RECOMENDADO POR LAS INSTRUCCIONES ESCRITAS O QUE NO ESTÉ PERMITIDO POR CUALQUIER LEGISLACIÓN APLICABLE U OTROS CÓDIGOS EN VIGOR EN LA UBICACIÓN DONDE USARÁ EL PRODUCTO EL COMPRADOR.

4.6 ANCLAR ESTE PRODUCTO AL SUELO ES ESENCIAL PARA SU ESTABILIDAD Y RIGIDEZ. ES NECESARIO COMPLETAR ESTA FASE PARA QUE SU GARANTIA SEA VALIDA.

Palram Canopia Ltd (Bolagsnummer: 512106824) vars registrerade huvudkontor har adressen: Teradion Industrial Park, M.P Misgav 20174, Israel ("Canopia") garanterar att produkten är felfri avseende material och bearbetning under en period av 15 år från inköpsdagen i enlighet med definitionerna och villkoren i denna garanti.

#### 1. Villkor

- Denna garanti gäller endast produkter som installerats, sköts, underhållits och hållits rena enligt anvisningarna i Canopias handbok (Rekommenderad användning: trädgårdsskötsel).
- Ovan nämnda garanti gäller inte vid skador till följd av alltför kraftig användning, fel eller olämplig användning, vårdslös installering, vårdslöst bruk eller underhåll, missöden, skador som främmande föremål gett upphov till, skadegörelse, smuts, förändringar, målning, fogar, limning, tejning, olämpliga tätningar eller skador som uppkommit på grund av olämpliga rengöringsmedel. Små avvikelser omfattas inte av garantin.
- Garantin täcker inte naturfenomen eller skador orsakade av dessa, såsom hagel, tung snö, storm, virvelvindar, orkaner, blixnar, vind eller översvämningar.
- Garantin gäller inte om man för växuset använder olämpliga byggsatser eller komponenter som inte rekommenderas av tillverkaren (Canopia).
- Garantin gäller endast den ursprungliga köparen/mottagaren. Garantin kan inte överföras till följande ägare eller en annan användare. taikka seuraaville omistajille.
- All annan användning för några andra syften vilar helt på användarens ansvar. Canopia fransäger sig allt ansvar för all annan användning än vad som rekommenderas i denna garanti.
- Reklamationer och anmälningar**
- Varje garantianspråk måste underrättas skriftligen till Canopia inom 30 dagar efter upptäckten av en defekt produkt, innehållande originalkvittot för försäljningen och den här garantin.
- Käranden (den som gjort reklamationen) ska låta tillverkaren/tillverkarens företrädare granska den felaktiga produkten på produktens ursprungliga plats i det skick som den är efter skadan. Produkten får inte ändras, repareras, flyttas eller skickas till tillverkaren/företrädaren innan tillstånd för detta har getts.
- Tillverkaren (Canopia) förbehåller sig rätten att självständigt undersöka orsaken till felet.
- Ersättning**
- När reklamationen har anmälts enligt villkoren i garantin och godkänts av Canopia har köparen (käranden) rätt att få nya delar eller en ny produkt eller en ersättning som står i proportion till skadan och anskaffningspriset enligt följande tabell:

Tid sedan anskaffning	Ersättande produkt/del	Ersättning
1 år sedan anskaffning	Utan avgift	100 %
1 => 2 år sedan anskaffning	Självrisk andel 10%	93 %
2 => 3 år sedan anskaffning	Självrisk andel 16%	86 %
3 => 4 år sedan anskaffning	Självrisk andel 22%	79 %
4 => 5 år sedan anskaffning	Självrisk andel 28%	72 %
5 => 6 år sedan anskaffning	Självrisk andel 34%	65 %
6 => 7 år sedan anskaffning	Självrisk andel 40%	58 %
7 => 8 år sedan anskaffning	Självrisk andel 46%	52 %
8 => 9 år sedan anskaffning	Självrisk andel 52%	46 %
9 => 10 år sedan anskaffning	Självrisk andel 58%	40 %
10 => 11 år sedan anskaffning	Självrisk andel 65%	34 %
11 => 12 år sedan anskaffning	Självrisk andel 72%	28 %
12 => 13 år sedan anskaffning	Självrisk andel 79%	22 %
13 => 14 år sedan anskaffning	Självrisk andel 86%	16 %
14 => 15 år sedan anskaffning	Självrisk andel 93%	10 %

- För att undvika alla misstankar, felkalkyleringar eller missförstånd vad gäller ersättning, beräknas den i tabellen framställda ersättningen alltid enligt den andel som den felaktiga/skadade delen utgör av hela produktens anskaffningspris. Tillverkaren förbehåller sig rätten att leverera en ersättande produkt/produkt del om originaldelar inte längre är tillgängliga eller om delarna eller produkterna är föråldrade.
- Garantin ersätter inte utgifter som orsakats av installering, nedmontering, flyttning eller reparation av produkten och inte heller utgifter som orsakats av direkta eller indirekta utgifter och förluster för att produkten haft fel eller skador, tex. skatter, flyttningsavgifter, leverans- och sändningsavgifter.
- Allmänna villkor och begränsningar**
- UTÖVER VAD SOM UTTRYCKLIGEN NÄMNS I DENNA GARANTI ÄR ALLA ÖVRIGA GARANTIERS ALLMÄNT BINDANDE VERKAN DIREKT ELLER INDIREKT GÄLLANDE ALLMÄN ELLER SÄRSKILD TILLÄMPNING UTESLUTNA INOM LAGENS RAMAR.
- MED UNDANTAG AV VAD SOM NÄMNS I DESSA GARANTIVILLKOR, ANSVARAR TILLVERKAREN INTE FÖR DE FÖRLUSTER ELLER SKADOR SOM KÖPAREN ELLER ANVÄNDAREN AV PRODUKTEN DIREKT ELLER INDIREKT ELLER TILL FÖLJD AV ANVÄNDNINGEN AV ELLER KONTAKTEN MED PRODUKTEN DRÄBBAS AV.
- OM TILLVERKAREN ENLIGT LOKAL LAGSTIFTNING ELLER UTFRÅN KONSUMENTSKYDDETS REKOMMENDATIONER NEKATS ATT INNEHÅLLA ERSÄTTNINGAR, TILLÄMPAS MED TANKE PÅ GARANTIER OM ALLMÄN ELLER SÄRSKILD TILLÄMPNING, GARANTIERNAS GILTIGHETSTID ENLIGT LOKAL LAGSTIFTNING PÅ PRODUKTEN.
- KÖPAREN ÄR ENSAM ANSVARIG FÖR ATT PRODUKTEN HANTERAS, FÖRVARAS OCH MONTERAS ÄNDAMÅLSENLIGT SAMT FÖR ATT DEN PLACERAS PÅ ETT TRYGGT STÅTT. CANOPIA ÄR INTE ANSVARIG FÖR NÅGRA MISSÖDEN ELLER SKADOR SOM ORSAKAS KÖPAREN, ANNAN PERSON ELLER PART ELLER DERAS EGENDOM OM DE BEROR PÅ ATT PRODUKTEN HANTERATS, FÖRVARATS, INSTALLERATS, MONTERATS PÅ FEL SÄTT ELLER PÅ GRUND AV ATT PRODUKTEN ANVÄNTS PÅ FEL SÄTT ELLER ATT ANVISNINGARNA INTE IAKTTAGITS.
- OM INGET ANNAT UTTRYCKLIGEN HAR ANGIVITS AV CANOPIA ÄR PRODUKTEN ENDAST AVSEDD FÖR NORMAL ANVÄNDNING I HEMMET OCH NORMAL KOMMERSIELL ANVÄNDNING. OM ANVÄNDNINGEN AV PRODUKTEN ENLIGT LOKAL LAGSTIFTNING ELLER ANDRA BESTÄMMELSER PÅ DEN PLATS DÄR KÖPAREN ANVÄNDER PRODUKTEN INTE ÄR TILLÄTNA, ANSVARAR CANOPIA INTE FÖR NÅGRA FÖRLUSTER, OLYCKSHÄNDELSER, KOSTNADER ELLER UTGIFTER SOM BEROR PÅ ATT PRODUKTEN ANVÄNTS PÅ FEL SÄTT, OBEROENDE AV FÖR VILKET ÄNDAMÅL PRODUKTEN ANVÄNTS.
- FORANKRING AV DENNA PRODUKT PÅ MARKEN ÄR NOVVDANDIGT FÖR STABILITET OCH STYVHET. DET ÄR NOVVDANDIGT ATT SLUTFORA DET HAR STEGET FÖR ATT DIN GARANTI SKA GALLA.

Palram Canopia Ltd (Selskapsnummer: 512106824) med hovedkontor i Teradion Industrial Park, M.P Misgav 20174, Israel ("Canopia") garanterer at Produktet vil være fri for mangler i materiale eller utførelse i en periode på 15 år fra originalen Kjøpsdato underlagt definisjonene, vilkårene og betingelsene i denne garantien.

#### 1. Betingelser

- Denne garantien gjelder kun hvis produktet er installert, rengjort, håndtert og vedlikeholdt i samsvar med Canopias skriftlige anbefalinger (Anbefalt bruk: Hobby hagearbeid).
- Uten unntak fra ovenstående skal skader forårsaket av bruk av kraft, feilaktig håndtering, uhensigtsmessig bruk, forsømmelig bruk eller montering eller vedlikehold, ulykker, innvirkning fra fremmedlegemer, hærverk, forurensninger, endring, maling, tilkobling, liming, forsegling ikke i samsvar med brukermanualen, eller skade som skyldes rengjøring med inkompatible vaskemidler og mindre avvik fra produktet, er ikke dekket av denne garantien.
- Denne garantien gjelder ikke for skade som skyldes "force majeure", som inkluderer, men er ikke begrenset til, hagl, storm, tornado, orkan, snøstorm, flom, brannvirkninger.
- Denne garantien er ugyldig dersom strukturelle deler og komponenter ikke er kompatible med Canopias skriftlige anbefalinger.
- Denne garantien gjelder bare for den opprinnelige kjøperen av produktet. Det strekker seg ikke til noen annen kjøper eller bruker av produktet (inkludert, men ikke begrenset til, noen som kjøper produktet fra den opprinnelige kjøperen).
- Enhver annen bruk til andre formål er på brukerens eget ansvar. Canopia fraskriver seg og påtar seg intet ansvar for bruk anbefales ikke av denne garantien.

#### 2. Krav og varsler

- Hvert garantibevis må bli meldt skriftlig til Canopia innen 30 dager etter oppdagelsen av det defekte produktet, vedlagt det originale salgskvitteringen og denne garantien.
- Saksøkeren må tillate Canopia å inspisere produktet og selve installasjonsstedet mens produktet fortsatt er i sin opprinnelige posisjon og ikke er fjernet eller flyttet eller endret på noen måte og / eller returnert produktet til Canopia for testing.
- Canopia forbeholder seg retten til å undersøke uavhengig årsaken til feil.

#### 3. Kompensasjon

- Hvis et krav i henhold til denne garantien er korrekt anmeldt og godkjent av Canopia, kan kjøperen ved Canopias valg enten (a) kjøpe et erstatningsprodukt eller deler / s; eller (b) motta tilbakebetaling av originalproduktets eller delens kjøpskurs, alt i samsvar med følgende tidsplan:

Periode etter innkjøp	Erstatningsprodukt eller del / s	Refusjon
Fra kjøpsdato fram til slutten av 1. år	Gratis	100%
Slutten av 1. år til slutten av 2. år	Kjøperen betaler 10% av den opprinnelige kjøpesummen	93%
Slutten av 2. år til slutten av 3. år	Kjøperen betaler 16% av den opprinnelige kjøpesummen	86%
Slutten av 3. år til slutten av 4. år	Kjøperen betaler 22% av den opprinnelige kjøpesummen	79%
Slutten av 4. år til slutten av 5. år	Kjøperen betaler 28% av den opprinnelige kjøpesummen	72%
Slutten av 5. år til slutten av 6. år	Kjøperen betaler 34% av den opprinnelige kjøpesummen	65%
Slutten av 6. år til slutten av 7. år	Kjøperen betaler 40% av den opprinnelige kjøpesummen	58%
Slutten av 7. år til slutten av 8. år	Kjøperen betaler 46% av den opprinnelige kjøpesummen	52%
Slutten av 8. år til slutten av 9. år	Kjøperen betaler 52% av den opprinnelige kjøpesummen	46%
Slutten av 9. år til slutten av 10. år	Kjøperen betaler 58% av den opprinnelige kjøpesummen	40%
Slutten av 10. år til slutten av 11. år	Kjøperen betaler 65% av den opprinnelige kjøpesummen	34%
Slutten av 11. år til slutten av 12. år	Kjøperen betaler 72% av den opprinnelige kjøpesummen	28%
Slutten av 12. år til slutten av 13. år	Kjøperen betaler 79% av den opprinnelige kjøpesummen	22%
Slutten av 13. år til slutten av 14. år	Kjøperen betaler 86% av den opprinnelige kjøpesummen	16%
Slutten av 14. år til slutten av 15. år	Kjøperen betaler 93% av den opprinnelige kjøpesummen	10%

- For å unngå tvil, vil beregning for bestemmelse om kompensasjon for defekte del / s, i henhold til oversikten ovenfor, være basert på den defekte delens bidrag til den opprinnelige prisen på produktet. Canopia forbeholder seg retten til å yte erstatning dersom produktet eller deler av det er utilgjengelig eller utelatt.
- Denne garantien dekker ikke eventuelle kostnader og kostnader ved fjerning og installasjon av produktet eller skatter eller fraktkostnader eller andre direkte eller indirekte tap som kan skyldes produktsvikt.
- Generelle vilkår og begrensninger**
- ANDRE, DER ER SPECIELLT STILT I DENNE GARANTIE, ER ALLE ANDRE GARANTIER, UTTRYKkelig ELLER UNDERFORSTÅTET, INKLUDERT ALLE UNDERFORSTÅTE GARANTIER OM SALGBARHET ELLER EGNETHET FOR ET PRAKTISK FORMÅL, UTTRYKKET SOM LOVGIVNINGEN GIJLEDER.
- BORTSETT FRA HVOR VI SPESIFIKT HAR ANGITT DENNE GARANTIE, ER CANOPIA IKKE ANSVARLIG FOR NOEN TAP, ELLER SKADER SOM KJØPER SIKKER DIREKTE, INDIREKTE ELLER SOM FØLGENDE ANVENDELSE ELLER PÅ EN ANNEN MÅDE SOM ER TILKNYTTET TIL PRODUKTET.
- HVIS CANOPIA ER FORBUDD I HENHOLD TIL EN GJELDENDE LOV UTTRYKkelig DE UNDERFORSTÅTE GARANTIER OM SALGBARHET ELLER EGNETHET FOR ET BESTEMT FORMÅL I FORBINDELSE MED PRODUKTET, ER VARIGHETEN FOR ALLE DENNE UNDERFORSTÅTE GARANTIER UTTRYKkelig BEGRENSET TIL VARIGHETEN AV DENNE GARANTIE ELLER LÅNGERE MAXIMUM PERIOD KRAVET AV GJELDENDE LOVGIVNING.
- KJØPEREN ER LIKT ANSVARLIG FOR Å BESTEMME OM HÅNDTERING, OPPBEVARING, MONTERING, INSTALLASJON ELLER BRUK AV PRODUKTET ER SIKKER OG TILGJENGELIG PÅ NOEN PLASSERING, FOR ANSVARLIG ANSØKNING ELLER I NOGEN OMSTENDIGHET. CANOPIA ER IKKE ANSVARLIG FOR NOEN SKADER ELLER SKADE TIL KJØPEREN, ANDRE PERSONER ELLER ENHETER EIENDOM SOM OPPFYLLES FRA DEN UBEGRENSEDE HÅNDTERING, OPPBEVARING, INSTALLASJON, MONTERING ELLER BRUK AV PRODUKTET ELLER MÅNGELINGEN TIL Å FØLGE SKRIFTLIGE INSTRUKSJONER VEDRØRENDE HÅNDTERING, OPPBEVARING, INSTALLASJON, MONTERING OG BRUK AV PRODUKTET.
- MED UNDERSØKELSE AV CANOPIA, UTTRYKkelig ANVIST, PRODUKTEN ER BEGRENSET TIL KUN FOR NORMAL BEGIVELSE OG KOMMERSIELL BRUK. CANOPIA ER IKKE ANSVARLIG FOR NOEN TAP, SKADER, KOSTNAD ELLER UTGIFTER SOM FØLGE AV EN ANVENDELSE AV PRODUKTET FOR NOGT FORMÅL SOM IKKE ER ANBEFALT AV DE SKRIFTLIGE INSTRUKSJONENE, ELLER DET ER IKKE GJELDET VED ANSVARLIG
- VENNLIGST MERK:** FORANKRING AV DETTE PRODUKTET TIL GRUNNEN ER VIKTIG FÖR STABILITET OG RIGIDITET. DET KREVES Å FULLFØRE DETTE TRINNET FOR AT DIN GARANTI SKAL VÆRE GYLDIG.

Palram Canopia Ltd (yhtiön rek.nro 512106824) jonka päätoimipiste toimii osoitteessa Teradion Industrial Park, M.P Misgav 20174, Israel. ("Canopia") takeita, että se valmistamissa tuotteissa ei sisälly virheitä materiaali- tai valmistusvirheitä, ja seuraavan 15 vuoden aikana alkuperäisestä ostopäivästä, joita on raportoitu olosuhteissa.

#### 1. Olosuhteet

- Tämä takuu on voimassa vain tuotteelle joka on ohjeen mukaisesti asennettu, hoidettu & ylläpidetty sekä pidetty puhtaana Canopiain ohjekirjassa antamien ohjeiden mukaisesti (Suositellaan käyttöä: Puutarhanhoitoharrastus).
- Poikkeamatta edellä mainitusta, vauriot jotka ovat syntyneet liiallisesta voiman käytöstä , väärästä tai sopimattomasta käytöstä , huolimattomasta asennuksesta , käytöstä tai ylläpidosta , vahingoista , vieraiden esineiden kolhuista , ilkivallasta epäpuhtauksista , muutoksista , maalauksista , liitoksista , liimauksista , teippauksista , sopimattomista tiivistyksistä tai vaurioista jotka ovat syntyneet yhteensopimattomista puhdistusaineista. Pienet poikkeamat eivät kuulu tämän takuun piiriin.
- Tämä takuu ei kata luonnonilmiöitä taikka niistä syntyneitä vaurioita kuten rakeet , raskas lumi, myrsky , pyörremyrsky , hirmumyrsky, salamat ,tuli taikka tulva.
- Tämä takuu on mitätön mikäli kasvihuoneen kanssa käytetään yhteensopimattomia rakenneosia taikka komponentteja jotka eivät ole vakmistajan (Canopia) suosituksen mukaisia.
- Tämä takuu on ainoastaan voimassa alkuperäiselle ostajalle / saajalle. Se ei ole jatkettavissa tai siirrettävissä toisille käyttäjille taikka seuraaville omistajille.
- Kaikki muu käyttö muihin tarkoituksiin on käyttäjän yksinomisella vastuulla.Canopia ei ole vastuussa mistään käytöstä, jota ei suositella tässä takuussa

#### 2. Reklamaatiot ja ilmoitukset

- Kaikki takuuvaatimukset on tehtävä kirjallisesti Canopiaalle 30 päivän sisällä viallisen tuotteen huomaamisesta, ja mukaan on liitettävä alkuperäinen ostokuitti ja tämä takuu.
- Kantajan (reklamaation tehnyt) tulee sällia valmistajan / valmistajan edustajan tarkistaa vioittunut tuote sen alkuperäisessä Sijainnissa siinä kunnossa kuin se on vaurion sattumisen jälkeen. Tuotetta ei saa muunnella , korjata , siirtää taikka lähettää valmistajalle / edustajalle ennen siihen saatua lupaa.

2.3 Valmistaja (Canopia) varaa oikeuden saada itsenäisesti tutkia vian syy.

#### 3. Korvaus

- Mikäli reklamaatio on takuun mukaisesti ilmoitettu ja hyväksytty Canopiaalta, on ostaja (kantaja) oikeutettu joko korvaaviin osiin / tuotteeseen taikka hyvitykseen joka on suhteessa vahinkoon & hankintahintaan seuraavan taulukon mukaisesti:

Aikaa hankinnasta	Korvaava tuote ja / tai osa	Korvaus
1 vuosi hankinnasta	Veloituksetta	100 <span> </span> %
1 => 2 ´teen vuoteen hankinnasta	Omavastuu 10 <span> </span> %	93 <span> </span> %
2 => 3 ´teen vuoteen hankinnasta	Omavastuu 16 <span> </span> %	86 <span> </span> %
3 => 4 ´teen vuoteen hankinnasta	Omavastuu 22 <span> </span> %	79 <span> </span> %
4 => 5 ´teen vuoteen hankinnasta	Omavastuu 28 <span> </span> %	72 <span> </span> %
5 => 6 ´teen vuoteen hankinnasta	Omavastuu 34 <span> </span> %	65 <span> </span> %
6 => 7 ´teen vuoteen hankinnasta	Omavastuu 40 <span> </span> %	58 <span> </span> %
7 => 8 ´teen vuoteen hankinnasta	Omavastuu 46 <span> </span> %	52 <span> </span> %
8 => 9 ´teen vuoteen hankinnasta	Omavastuu 52 <span> </span> %	46 <span> </span> %
9 => 10 ´teen vuoteen hankinnasta	Omavastuu 58 <span> </span> %	40 <span> </span> %
10 => 11 ´teen vuoteen hankinnasta	Omavastuu 65 <span> </span> %	34 <span> </span> %
11 => 12 ´teen vuoteen hankinnasta	Omavastuu 72 <span> </span> %	28 <span> </span> %
12 => 13 ´teen vuoteen hankinnasta	Omavastuu 79 <span> </span> %	22 <span> </span> %
13 => 14 ´teen vuoteen hankinnasta	Omavastuu 86 <span> </span> %	16 <span> </span> %
14 => 15 ´teen vuoteen hankinnasta	Omavastuu 93 <span> </span> %	10 <span> </span> %

- Välitykseen mittään epäilyiltä , laskentavirheiltä tai väärinkäsityksiltä korvattavuuden suhteen edellä esitetyn taulukon mukainen korvaus lasketaan aina viallisen / vioittuneen osan osuudesta kokonaistuotteen hankinta- arvosta. Valmistaja varaa oikeuden toimittaa korvaava tuote / tuoteosa mikäli alkuperäistä osaa ei ole enää saatavissa tai se on vanhentunut.

- Tämä takuu ei korvaa kuluja jotka ovat syntyneet asennuksesta, purkauksesta, tuotteen siirtämisestä tai korjaustyöstä eikä myöskään suorista tai epäsuorista kuluista & menetyksistä kuten veroista, muutoista, toimitus- & lähetykseluista jotka ovat syntyneet tuotteen viallisuudesta tai vioittuneisuudesta.

#### 4. Yleiset ehdot ja rajoitukset

- MUILTA OSIN KUIN NIMENOMAISESTI TÄSSÄ TAKUUSSA ON ESITETTY, KAIKKIEN MUIDEN TAKUIDEN YLEISTOVUUDET KAUPALLISESTA HYÖDYNNETTÄVYYDESTÄ TAI SOPIVUUDESTA SUORAAN TAI VÄLILLISESTI OVAT POISSULJETTU SIKÄLI KUIN LAKI SALLII.
- POSLUKIEN MITÄ NÄISSÄ TAKUUEHDUISSA ON ESITETTY, VALMISTAJA EI VASTAA MISTÄÄN TAPPIOISTA TAI VAHINGOISTA MITÄ OSTAJA TAI TUOTTEEN KÄYTTÄJÄ KÄRSII SUORAAN, VÄLILLISESTI TAI SEURAUKSENA TUOTTEEN KÄYTTÄMISESTÄ TAI YHTEYDESTÄ TUOTTEESEEN.
- MIKÄLI VALMISTAJAA ON KIELLETTY EVÄTÄ PAIKALLISESTI SOVELLETTAVAN LAINSÄÄDÄNNÖN TAI KULTTUUSUOJA SUOSTUSTEN POHIALTA TAKUUEHTOJEN MUKAISIA KORVAUKSIA – SOVELLETAAN YLEISESTI KAUPALLISESTI HYÖDYNNETTÄVYYDESTÄ TAI SOPIVUUDESTA TIETTYYN TARKOITUKSEEN NÄHDEN TUOTTEEN OLEVAN TAKUIDEN VOIMASSAOLOAIKAA PAIKALLISEN LAIN MUKAAN.
- OSTAJA ON YKSIN VASTUUSSA ASIANMUKAISESTA KÄSITTELYSTÄ, VARASTOINNISTA, KOKOONPANOSTA SEKÄ TURVALLISESTA SIAJAINNISTAETTÄ KÄYTÖSTÄ JA SÄILYTYKSESTÄ. CANOPIA EI OLE VASTUUSSA MISTÄÄN VAHINGOISTA TAI VAMMOISTA OSTAJALLE, MUULLE HENKILÖLLE TAI OSAPUOLELLE TAI HÄNEN OMAISUUDELLE MIKÄLI NE JOHTUVAT VÄÄRÄSTÄ KÄSITTELYSTÄ, VARASTOINNISTA, ASENNUKSESTA, KOKOAMISESTA TAI TUOTTEEN VÄÄRÄSTÄ KÄYTÖSTÄ TAI OHJEIDEN NOUDATTAMATTA JÄTTÄMISESTÄ.
- JOS EI MUUTEN ERIKSEEN ILMOITETA CANOPIAIN TAHOLTA, TÄMÄ TUOTE ON TARKOITETTU VAIN TAVALLISEEN KOTI- JA KAUPALLISEEN KÄYTTÖÖN.CANOPIA EI OLE VASTUUSSA MISTÄÄN MENETYKSESTÄ, VAHINGOSTA, KUSTANNUKSISTA TAI KULUISTA JOTKA JOHTUVAT TUOTTEEN VÄÄRÄSTÄ KÄYTÖSTÄ MIHIN TAHANSA TARKOITUKSEEN, MIKÄLI EI OLLA NOUDATTETTU SUOSITELTUA KIRJALLISIA OHJEITA TAI JOS KÄYTTÖ EI OLE SALLITTUA SOVELLETTAVAN LAINSÄÄDÄNNÖN TAI MUIDEN ASETUSTEN MUKAAN PAIKASSA JOSSA OSTAJA KÄYTTÄÄ TUOTETTA.
- TUOTTEEN ANKKUROINTI MAAHAN ON VALTTAMATONTA SEN VAKAUJEN JA JAYKKYDEN KANNALTA. SE VAADITAAN TASSA VAIHEESSA, JOTTA TAKUU OLISI VOIMASSA.

Palram Canopia Ltd. (Virksomhedsregistreringsnummer: 512106824), registreret på adressen Teradion Industrial Park, M.P Misgav 20174, Israel ("Canopia"), garanterer at Produktet ikke lider af materiellej eller fabrikkationsfej i en periode på 15 år fra købsdatoen, underlagt definitionerne og vilkårene indeholdt i denne garanti.

#### 1. Vilkår

- Denne garanti er kun gældende, hvis Produktet er installeret, rengjort, håndteret og vedligeholdt i overensstemmelse med Canopias skrevne anbefalinger (Anbefalet brug: Fritidshavearbejde).
- Uden at afvige fra det ovennævnte, er skade opstået grundet brug af fysisk magt, ukorrekt håndtering, upassende brug, forsømmelig brug, samling eller vedligeholdelse, uheld, indvirkning fra fremmedlegemer, vandalisme, forurenende stoffer, ændringer, maling, tilslutning, limning, forsegling, der ikke er i overensstemmelse med brugsvejledningen, eller skade som resultat af rengøring med ikke-kompatible rengøringsmidler og mindre afvigelser ved Produktet ikke dækket af denne garanti.
- Denne garanti dækker ikke skade som resultat af "naturens handling", hvilket omfatter, men er ikke begrænset til hagl, storm, tornadoer, orkaner, snestorme, oversvømmelse, følger af brand.
- Denne garanti er ugyldig, hvis der benyttes konstruktionsdele og løse dele, der ikke er kompatible med Canopias skrevne anbefalinger.
- Denne garanti er kun gældende for Produktets oprindelige køber. Den omfatter ikke andre købere eller brugere af Produktet (inklusiv, men ikke begrænset til, enhver person der erhverver Produktet fra den oprindelige køber).
- Enhver anden anvendelse til ethvert andet formål er på brugerens eget ansvar. Canopia fraskriver sig alt ansvar for enhver brug, der ikke anbefales af denne garanti.

#### 2. Krav og Bekendtgørelser

- Ethvert garantikrav skal bekendtgøres skriftligt til Palgram inden for 30 dage, efter opdagelsen af det defekte Produkt, og vedlægges den originale kvittering og denne garanti.
- Skadesanmelderen skal lade Canopia undersøge Produktet, der er tale om, og selve installationen, mens Produktet stadig befinder sig i sin oprindelige position og ikke er blevet fjernet eller flyttet eller ændret på nogen måde, og/eller lade produktet sende tilbage til Canopia for afprøvning.
- Canopia forbeholder sig retten til selvstændigt at undersøge årsagen til dette funktionssvigt.

#### 3. Erstatning

- Hvis et krav i henhold til denne garanti bekendtgøres korrekt og godkendes af Canopia, kan køberen, efter Canopias valg, (a) købe et erstatningsprodukt eller del/e, eller (b) modtage refundering for det oprindelige Produkts eller del/es købspris, alt i henhold til den følgende oversigt:

Periode Efter Køb	Erstatningsprodukt eller Delle	Refundering
Fra købsdato til udgangen af 1. år	Uden beregning	100 <span> </span> %
Udgangen af 1. år til udgangen af 2. år	køber vil betale 10 <span> </span> % af den oprindelige købspris	93 <span> </span> %
Udgangen af 2. år til udgangen af 3. år	køber vil betale 16 <span> </span> % af den oprindelige købspris	86 <span> </span> %
Udgangen af 3. år til udgangen af 4. år	køber vil betale 22 <span> </span> % af den oprindelige købspris	79 <span> </span> %
Udgangen af 4. år til udgangen af 5. år	køber vil betale 28 <span> </span> % af den oprindelige købspris	72 <span> </span> %
Udgangen af 5. år til udgangen af 6. år	køber vil betale 34 <span> </span> % af den oprindelige købspris	65 <span> </span> %
Udgangen af 6. år til udgangen af 7. år	køber vil betale 40 <span> </span> % af den oprindelige købspris	58 <span> </span> %
Udgangen af 7. år til udgangen af 8. år	køber vil betale 46 <span> </span> % af den oprindelige købspris	52 <span> </span> %
Udgangen af 8. år til udgangen af 9. år	køber vil betale 52 <span> </span> % af den oprindelige købspris	46 <span> </span> %
Udgangen af 9. år til udgangen af 10. år	køber vil betale 58 <span> </span> % af den oprindelige købspris	40 <span> </span> %
Udgangen af 10. år til udgangen af 11. år	køber vil betale 65 <span> </span> % af den oprindelige købspris	34 <span> </span> %
Udgangen af 11. år til udgangen af 12. år	køber vil betale 72 <span> </span> % af den oprindelige købspris	28 <span> </span> %
Udgangen af 12. år til udgangen af 13. år	køber vil betale 79 <span> </span> % af den oprindelige købspris	22 <span> </span> %
Udgangen af 13. år til udgangen af 14. år	køber vil betale 86 <span> </span> % af den oprindelige købspris	16 <span> </span> %
Udgangen af 14. år til udgangen af 15. år	køber vil betale 93 <span> </span> % af den oprindelige købspris	10 <span> </span> %

- For at undgå tvivl vil beregning for bestemmelse af erstatning for defekt(e) del/e, i henhold til oversigten ovenfor, blive baseret på den defekte dels dækning i forhold til Produktets oprindelige pris. Canopia forbeholder sig retten til at levere erstatninger, hvis Produktet, eller nogen del af dette, er utilgængeligt eller forældet.

- Denne garanti dækker ikke omkostninger eller udgifter ved fjernelse og installation af Produktet, eller afgifter, eller forsendelsesomkostninger, eller nogen direkte eller indirekte tab, der kan opstå grundet Produktfej,

#### 4. Almindelige Betingelser og Begrænsninger

- UD OVER HVAD DER ER BLEVET SPECIFIK ANFØRT I DENNE GARANTI, ER ALLE ANDRE GARANTIER, OM UDTRYKT ELLER UNDERFORSTÅET, OMFATTENDE ALLE UNDERFORSTÅEDE GARANTIER VEDRØRENDE SALGBARHED ELLER EGNETHED TIL ET SPECIFIK FORMÅL UNDTAGET FOR SÅ VIDT LOVEN TILLADER
- MED UNDTAGELSE AF, HVOR VI HAR SPECIFIKT ANFØRT DET I DENNE GARANTI, ER CANOPIA IKKE ANSVARLIG FOR NOGEN TAB ELLER SKADER, SOM KØBEREN LIDER DIREKTE, INDIREKTE, ELLER SOM EN FØLGE AF BRUG, ELLER PÅ NOGEN ANDEN MÅDE FORBINDELSE TIL PRODUKTET.
- HVIS CANOPIA UDELUKKES FRA, I HENHOLD TIL ENHVER GÆLDENDE LOV, AT UNDTAGE DEN UNDERFORSTÅEDE SALGBARHEDS ELLER EGNETHEDSGARANTI FOR ET SPECIFIK FORMÅL I FORHOLD TIL PRODUKTET, ER VARIGHEDEN AF ALLE SÅDANNE UNDERFORSTÅEDE GARANTIER UDTRYKKELIG BEGRÆNSET TIL VARIGHEDEN AF DENNE GARANTI, ELLER, HVIS LÆNGERE, DEN MAKSIMALE PERIODE KRÆVET AF GÆLDENDE LOVGIVNING.
- KØBEREN ER ENEANSVARLIG FOR AT BESLUTTE OM HÅNTERINGEN, OPBEVARINGEN, SAMLINGEN, INSTALLATIONEN ELLER BRUGEN AF PRODUKTET ER SIKKERT OG PASSENDE PÅ ETHVERT OMRÅDE, TIL ENHVER APPLIKATION ELLER UNDER ETHVERT GIVENT FORHOLD. CANOPIA ER IKKE ANSVARLIG FOR NOGEN SKADER ELLER KVÆSTELSER KØBER, ENHVER ANDEN PERSON, ELLER EJENDOM MÅTTE LIDE, SOM RESULTAT AF UKORREKT HÅNTERING, OPBEVARING, INSTALLATION, SAMLING ELLER BRUG AF PRODUKTET ELLER UNDLADELSE AF AT FØLGE DE SKREVNE ANBEFALINGER VEDRØRENDE HÅNTERING, OPBEVARING, INSTALLATION, SAMLING OG BRUG AF PRODUKTET.
- MEDMINDRE ANDET UDTRYKKELIGT ER ANGIVET AF CANOPIA, PRÆPARATET ER BEREGNET TIL ALMINDELIG BRUG I HJEMMET OG KOMMERCIEL BRUG. CANOPIA ER IKKE ANSVARLIG FOR TAB, SKADE, OMKOSTNINGER ELLER UDGIFTER SOM RESULTAT AF NOGEN BRUG AF PRODUKTET TIL NOGET, DER IKKE ER ANBEFALET I DE SKREVNE ANBEFALINGER, ELLER IKKE ER TILLADT I HENHOLD TIL NOGEN GÆLDENDE LOVGIVNING ELLER ANDRE GÆLDENDE REGLER PÅ DET STED, HVOR KØBER VIL BRUGE PRODUKTET.
- FORANKRING AF DETTE PRODUKT TIL JORDEN ER AFGØRENDE FOR DETS STABILITET OG STYRKE. FOR AT SIKRE GYLDIGHEDEN AF DIN GARANTI, KRVES DET, AT DU GENNEMFORER DETTE TRIN.

Palram Canopia Ltd (Bedrijfsnummer: 512106824) met maatschappelijke zetel te Teradion Industrial Park, M.P Misgav 20174, Israël ("Canopia") garandeert dat het product vrij is van materiaal- en fabricagefouten voor een periode van 15 jaar vanaf de oorspronkelijke datum van aankoop door de definities en voorwaarden van deze garantie.

#### 1. Voorwaarden

- Deze garantie is alleen geldig indien het Product is geïnstalleerd, gereinigd, gebruikt en onderhouden in overeenstemming met de geschreven aanbevelingen van Canopia (Aanbevolen gebruik hobby tuinieren).
- Zonder af te wijken van het bovenstaande, zal schade veroorzaakt door gebruik van geweld, onjuist gebruik, oneigenlijk gebruik, nalatig gebruik of montage of onderhoud, ongevallen, botsing met vreemde voorwerpen, vandalisme, vervuiling, aanpassingen, schilderen, verbinden, lijmen, afdichten op een wijze die niet in overeenstemming is met de handleiding, of schade als gevolg van reiniging met incompatibele schoonmaakmiddelen en geringe afwijkingen van het Product niet vallen onder deze garantie.
- Deze garantie geldt niet voor schade als gevolg van "overmacht", inclusief maar niet beperkt tot, hagel, onweer, tornado's, orkanen, sneeuwstormen, overstromingen, gevolgen van brand.
- Deze garantie vervalt als structurele onderdelen en onderdelen die worden gebruikt niet compatibel zijn met schriftelijke aanbevelingen van Canopia.
- Deze garantie geldt alleen voor de oorspronkelijke koper van het Product. Zij geldt niet voor een andere koper of gebruiker van het Product (inclusief, maar niet beperkt tot, elke persoon die het product koopt van de oorspronkelijke koper).
- Elk ander gebruik voor iets anders dan waar het voor bedoeld is valt onder de verantwoordelijkheid van de gebruiker. Canopia verwerpt en aanvaardt geen aansprakelijkheid voor elk gebruik dat niet wordt aanbevolen door deze garantie.

#### 2. Claims en meldingen

- Elke garantiemelding dient bij Canopia te worden ingediend binnen 30 dagen na de ontdekking van het defecte product, met bijvoeging van het originele koopbewijs en deze garantie.
- De eiser moet het Canopia mogelijk maken het betrokken product en de constructielocatie zelf te inspecteren, met het product nog in de oorspronkelijke positie en niet verwijderd of verplaatst of op engerlei wijze veranderd en/of het product terugzenden naar Canopia om te laten testen.
- Canopia behoudt zich het recht om zelfstandig de oorzaak van een probleem te onderzoeken.
- Compensatie**
- Indien een claim onder deze garantie goed is aangemeld en door Canopia is goedgekeurd, mag de koper, naar Canopias keuze, ofwel (a) een vervangend product of onderdeel(e)len aanschaffen, of (b) het aankoopbedrag van het oorspronkelijke product of onderdeel(e)len terugkrijgen, alles in overeenstemming met het volgende schema:

Periode na aankoop	vervangende product of onderdeel(e)len Teruggave	Teruggave
Vanaf de aankoopdatum tot het eind van 1e jaar	Gratis	100 %
Einde van 1 <sup>e</sup> jaar tot einde van 2 <sup>e</sup> jaar	koper betaalt 10% van het oorspronkelijke aankoopbedrag	93 %
Einde van 2 <sup>e</sup> jaar tot einde van 3 <sup>e</sup> jaar	koper betaalt 16% van het oorspronkelijke aankoopbedrag	86 %
Einde van 3 <sup>e</sup> jaar tot einde van 4 <sup>e</sup> jaar	koper betaalt 220% van het oorspronkelijke aankoopbedrag	79 %
Einde van 4 <sup>e</sup> jaar tot einde van 5 <sup>e</sup> jaar	koper betaalt 28% van het oorspronkelijke aankoopbedrag	72 %
Einde van 5 <sup>e</sup> jaar tot einde van 6 <sup>e</sup> jaar	koper betaalt 34% van het oorspronkelijke aankoopbedrag	65 %
Einde van 6 <sup>e</sup> jaar tot einde van 7 <sup>e</sup> jaar	koper betaalt 40% van het oorspronkelijke aankoopbedrag	58 %
Einde van 7 <sup>e</sup> jaar tot einde van 8 <sup>e</sup> jaar	koper betaalt 46% van het oorspronkelijke aankoopbedrag	52 %
Einde van 8 <sup>e</sup> jaar tot einde van 9 <sup>e</sup> jaar	koper betaalt 52% van het oorspronkelijke aankoopbedrag	46 %
Einde van 9 <sup>e</sup> jaar tot einde van 10 <sup>e</sup> jaar	koper betaalt 580% van het oorspronkelijke aankoopbedrag	40 %
Einde van 10 <sup>e</sup> jaar tot einde van 11 <sup>e</sup> jaar	koper betaalt 65% van het oorspronkelijke aankoopbedrag	34 %
Einde van 11 <sup>e</sup> jaar tot einde van 12 <sup>e</sup> jaar	koper betaalt 72% van het oorspronkelijke aankoopbedrag	28 %
Einde van 12 <sup>e</sup> jaar tot einde van 13 <sup>e</sup> jaar	koper betaalt 79% van het oorspronkelijke aankoopbedrag	22 %
Einde van 13 <sup>e</sup> jaar tot einde van 14 <sup>e</sup> jaar	koper betaalt 86% van het oorspronkelijke aankoopbedrag	16 %
Einde van 14 <sup>e</sup> jaar tot einde van 15 <sup>e</sup> jaar	koper betaalt 93% van het oorspronkelijke aankoopbedrag	10 %

- Voor alle duidelijkheid, de berekening van de bepaling van de compensatie voor defecte onderdeel(e)len, volgens het bovenstaande schema, zal worden gebaseerd op de bijdrage van het defecte onderdeel op de oorspronkelijke kosten van het product. Canopia behoudt zich het recht voor vervangingen te leveren indien het product of enig deel daarvan niet beschikbaar of verouderd is.
- Deze garantie dekt geen kosten en uitgaven van de verwijdering en installatie van het Product of belastingen of verzendkosten of enige andere directe of indirecte schade(s) die kan/kunnen voortvloeien uit het defect van het product.
- Algemene voorwaarden en beperkingen**
- ANDERS DAN SPECIEK IN DEZE GARANTIE AANGEGEVEN, ZIJN ALLE ANDERE GARANTIES, HETZIJ EXPLICIET OF IMPLICIET, INCLUSIEF ALLE IMPLICIETE GARANTIES VAN VERKOOPBAARHEID OF GESCHIKTHEID VOOR EEN BEPAALD DOEL UITGESLOTEN VOOR ZOVER DE WET DIT TOELAAT.
- BEHALVE WAAR WE DAT SPECIEK HEBBEN AANGEGEVEN IN DEZE GARANTIE, ZAL CANOPIA NIET VERANTWOORDELIJK VOOR VERLIES OF SCHADE DIE DE KOPER LIJDT, DIRECT OF INDIRECT, OF ALS GEVOLG VAN HET GEBRUIK, OF OP WELKE ANDERE WIJZE DAN OOK IN VERBAND MET HET PRODUCT.
- ALS HET CANOPIA VERBODEN IS ONDER DE TOEPASSELIJKE WETGEVING DE GARANTIES VAN VERKOOPBAARHEID OF GESCHIKTHEID UIT TE SLUITEN VOOR EEN BEPAALD DOEL MET BETREKING TOT HET PRODUCT, IS DE DUUR VAN ALLE DERGELIJKE IMPLICIETE GARANTIES UITDRUKKELIJK BEPERKT TOT DE DUUR VAN DEZE GARANTIE OF, INDIEN LANGER, TOT DE MAXIMALE PERIODE VEREIST IN DE TOEPASSELIJKE WETGEVING.
- DE KOPER IS ZELF GEHEEL VERANTWOORDELIJK OM TE BEPALEN OF HET HANTEREN, DE OPSLAG, MONTAGE, INSTALLATIE OF HET GEBRUIK VAN HET PRODUCT OP ELKE LOCATIE VEILIG EN PASSEND IS, GESCHIKT IS VOOR HET DOEL OF PASSEND ONDER DE GEGEVEN OMSTANDIGHEDEN IS. CANOPIA IS NIET VERANTWOORDELIJK VOOR ENIGE SCHADE OF LETSEL AAN DE KOPER, EEN ANDERE PERSOON OF ENIGE ANDERE ZAKEN ALS GEVOLG VAN ONDOELMATIG GEBRUIK, OPSLAG, INSTALLATIE, MONTAGE OF HET GEBRUIK VAN HET PRODUCT OF HET NIET VOLGEN VAN DE SCHRIFTELIJKE AANWIJZINGEN BETREFFENDE HET HANTEREN, OPSLAAN, INSTALLEREN, MONTEREN EN GEBRUIK VAN HET PRODUCT.
- TENZIJ NADRUUKELIJK ANDERS AANGEGEVEN DOOR CANOPIA, IS HET PRODUCT ALLEEN BEDOELD VOOR NORMAAL RESIDENTIEEL EN COMMERCIEEL GEBRUIK. CANOPIA IS NIET VERANTWOORDELIJK VOOR VERLIES, SCHADE, KOSTEN OF UITGAVEN ALS GEVOLG VAN HET GEBRUIK VAN HET PRODUCT VOOR ENIG DOEL DAT NIET IS AANBEVOLEN IN DE SCHRIFTELIJKE INSTRUCTIES OF DAT NIET IS TOEGESTAAN VANWEGE ENIGE TOEPASSELIJKE WETGEVING OF ANDERE GEBRUIKEN OP DE LOCATIE WAAR DE KOPER HET PRODUCT ZAL GEBRUIKEN.
- VERANKERING VAN DIT PRODUCT AAN DE GROND IS VAN ESSENTEEL BELANG VOOR DE STABILITEIT EN STEVIGHEID. DEZE FASE DIENT TE WORDEN VOLTOOID, OM UW GARANTIE GELDIG TE LATEN BLIJVEN.

Palram Canopia Ltd (società numero: 512106824) i cui uffici registrati hanno sede a Teradion Industrial Park, M.P Misgav 20174000, Israele ("Canopia") garantisce che il Prodotto sarà privo da difetti di materiale o di lavorazione in un periodo di 15 anni dalla data originale. d'acquisto soggetta alle definizioni, termini e condizioni contenute in questa garanzia.

#### 1. Condizioni

- La presente garanzia sarà valida solo se il Prodotto è installato, pulito, trattato e mantenuto secondo le raccomandazioni scritte di Canopia (Uso raccomandato: Giardinaggio amatoriale).
- Senza deroga e quanto descritto sopra, i danni causati da forzature, trattamento incorretto, uso inappropriato, uso disattento o assemblaggio o manutenzione, incidenti, impatto da oggetti estranei, vandalismo, inquinanti, alterazioni, pittura, connessioni, incollature, chiusura non conformi al manuale utente o danni derivanti dalla pulizia con detersivi incompatibili e variazioni minori al Prodotto non sono coperti dalla presente garanzia.
- La presente garanzia non è valida per i danni derivanti da cause di forza maggiore che includono, ma non si limitano a, grandine, tempeste, tornado, uragani, bufere di neve, allagamenti, effetti del fuoco.
- La presente garanzia si ritiene nulla se le parti strutturali e i componenti usati non sono compatibili con le raccomandazioni scritte di Canopia.
- La presente garanzia è valida solo per l'acquirente originario del Prodotto. Tale garanzia non si estende ad altri acquirenti o utenti del Prodotto (che includono, ma non si limitano a, ogni persona che acquista il Prodotto dall'acquirente).
- Ogni altro uso per qualunque altro scopo è sotto la responsabilità esclusiva dell'utente. Canopia declina e non si assume alcuna responsabilità per qualsiasi uso non raccomandato dalla presente garanzia.

#### 2. Richieste e notifiche

- Ogni richiesta in garanzia deve essere notificata a Canopia per iscritto entro 30 giorni dalla scoperta del Prodotto difettoso, allegando la ricevuta di acquisto originale e la presente garanzia.
- Il richiedente deve consentire a Canopia di ispezionare il Prodotto in questione e lo stesso sito di installazione mentre il Prodotto è ancora nella sua posizione originale e non è stato rimosso, spostato o alterato in alcun modo e/o restituire il Prodotto a Canopia per effettuare una prova.
- Canopia si riserva il diritto di indagare in modo indipendente la causa di qualsiasi avaria.

#### 3. Risarcimento

- Se la richiesta sotto garanzia viene notificata in modo appropriato e approvata da Canopia, l'acquirente potrà, secondo l'opzione offerta da Canopia, (a) acquistare un Prodotto in sostituzione o una o più parti, oppure (b) ricevere un risarcimento del Prodotto originale o del prezzo di acquisto di una o più parti, tutte in conformità alla seguente tabella:

Periodo dopo l'acquisto	Prodotto o parte/i in sostituzione	Risarcimento
Dalla data di acquisto fino alla fine del primo anno	Gratuito	100 %
Fine del primo anno fino alla fine del secondo anno	l'acquirente pagherà il 10% del prezzo originale	93 %
Fine del secondo anno fino alla fine del terzo anno	l'acquirente pagherà il 16% del prezzo originale	86 %
Fine del terzo anno fino alla fine del quarto anno	l'acquirente pagherà il 22% del prezzo originale	79 %
Fine del quarto anno fino alla fine del quinto anno	l'acquirente pagherà il 28% del prezzo originale	72 %
Fine del quinto anno fino alla fine del sesto anno	l'acquirente pagherà il 34% del prezzo originale	65 %
Fine del sesto anno fino alla fine del settimo anno	l'acquirente pagherà il 40% del prezzo originale	58 %
Fine del settimo anno fino alla fine del tondo anno	l'acquirente pagherà il 46% del prezzo originale	52 %
Fine del tondo anno fino alla fine del nono anno	l'acquirente pagherà il 52% del prezzo originale	46 %
Fine del nono anno fino alla fine del decimo anno	l'acquirente pagherà il 58% del prezzo originale	40 %
Fine del decimo anno fino alla fine del undicesimo anno	l'acquirente pagherà il 65% del prezzo originale	34 %
Fine del undicesimo anno fino alla fine del dodicesimo anno	l'acquirente pagherà il 72% del prezzo originale	28 %
Fine del dodicesimo anno fino alla fine del tredicesimo anno	l'acquirente pagherà il 79% del prezzo originale	22 %
Fine del tredicesimo anno fino alla fine del quattordicesimo anno	l'acquirente pagherà il 86% del prezzo originale	16 %
Fine del quattordicesimo anno fino alla fine del quindicesimo anno	l'acquirente pagherà il 93% del prezzo originale	10 %

- Onde evitare ogni dubbio, il calcolo per determinare il risarcimento per la/e parti difettose, secondo la tabella di cui sopra, verrà basato sulla contribuzione della parte difettosa sul costo originale del Prodotto. Canopia si riserva il diritto di fornire sostituzioni se il Prodotto o qualsiasi parte di esso sia obsoleta o non disponibile.
- La presente garanzia non copre alcun costo o spesa relativa alla rimozione e all'installazione del Prodotto, imposte, spese di spedizione o qualsiasi altra/e perdita/e diretta/e o indiretta/e derivante/i dal Prodotto avariato.
- Condizioni generali e limitazioni**
- DIVERSAMENTE DA QUANTO È STATO SPECIFICATO NELLA PRESENTE GARANZIA, TUTTE LE ALTRE GARANZIE, ESPRESSE O IMPLICITE, COMPRESSE TUTTE LE GARANZIE IMPLICITE DI COMMERCIALITÀ O IDONEITÀ PER UNO SCOPO PARTICOLARE SONO ESCLUSE SECONDO LE LEGGI VIGENTI.
- ECCETTO SE SPECIFICAMENTE INDICATO NELLA PRESENTE GARANZIA, CANOPIA NON SARÀ RESPONSABILE DI ALCUNA PERDITA O DANNI SUBITI DALL'ACQUIRENTE, DIRETTAMENTE O INDIRECTAMENTE, COME CONSEGUENZA DELL'USO O LEGATI IN QUALSIASI ALTRO MODO AL PRODOTTO.
- SE LA LEGGE VIGENTE NON CONSENTE A CANOPIA DI ESCLUDERE LE GARANZIE IMPLICITE DI COMMERCIALITÀ O IDONEITÀ PER UNO SCOPO PARTICOLARE IN RELAZIONE AL PRODOTTO, LA DURTA DI TALI GARANZIE IMPLICITE VIENE ESPRESSAMENTE LIMITATA ALLA DURATA DELLA PRESENTE GARANZIA O, SE PRESENTA DURATA MAGGIORE, AL PERIODO MASSIMO PREVISTO DALLE LEGGI VIGENTI.
- L'ACQUIRENTE È IL SOLO RESPONSABILE NEL DETERMINARE SE IL TRATTAMENTO, LA CONSERVAZIONE, L'ASSEMBLAGGIO, L'INSTALLAZIONE DEL PRODOTTO SIA SICURA E OPPORTUNA IN QUALSIASI LUOGO, PER QUALSIASI SCOPO O IN QUALSIASI CIRCOSTANZA. CANOPIA NON È RESPONSABILE DI ALCUN DANNO O FERITE SUBITE DALL'ACQUIRENTE, O QUALSIASI ALTRA PERSONA O PROPRIETÀ DERIVANTI DA TRATTAMENTO, CONSERVAZIONE, INSTALLAZIONE, ASSEMBLAGGIO O USO IMPROPRIO DEL PRODOTTO O DALLA MANCATA OSSERVANZA DELLE ISTRUZIONI RELATIVE A TRATTAMENTO, CONSERVAZIONE, INSTALLAZIONE, ASSEMBLAGGIO E USO DEL PRODOTTO.
- A MENO CHE NON SIA ESPRESSAMENTE INDICATO DA CANOPIA, IL PRODOTTO È INTESO SOLTANTO PER UN USO NORMALE, LOCALE E COMMERCIALE. CANOPIA NON È RESPONSABILE DI ALCUNA PERDITA, DANNO, COSTO O SPESA DERIVANTI DALL'USO DEL PRODOTTO PER QUALSIASI ALTRO SCOPO NON SUGGERITO NELLE ISTRUZIONI O CHE NON VENGA PREVISTO DALLA LEGISLAZIONE VIGENTE O DA ALTRI CODICI VIGENTI NELLA LOCALITÀ DOVE L'ACQUIRENTE USERÀ IL PRODOTTO.
- IT FISSAGGIO DI QUESTO PRODOTTO A TERRA È ESSENZIALE PER OTTENERE STABILITY E RIGIDITY. AFFINCHÉ LA GARANZIA SIA VALIDA A NECESSARIO COMPLETARE QUESTO PASSAGGIO.