

# Owner's Manual & Assembly Guide

**! caution**  
sharp edges \*

Gloves must be worn at all times to reduce risk of injury!



Model No. STB63

**6' x 3'**  
Nominal Size

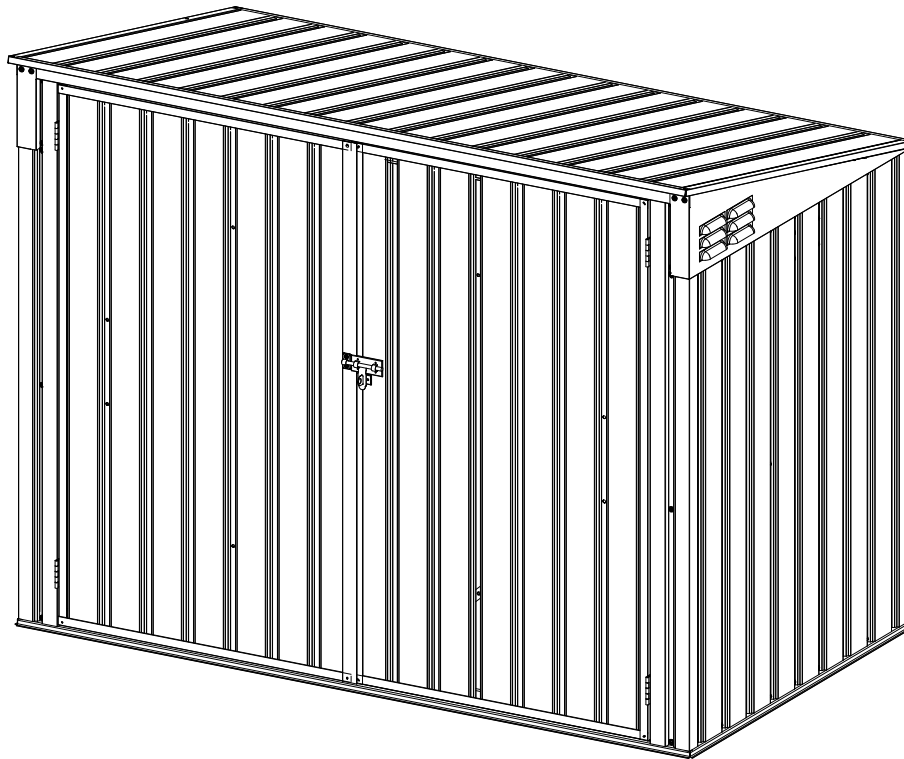

<b>Base Size</b>	68 5/8" x 39 3/8" 174,3 cm x 100,0 cm
------------------	--

**BUILDING DIMENSIONS**

† Size rounded off to the nearest foot

For proper base construction see page 11

Approx. † Size	Storage Area		Exterior Dimensions (Roof Edge to Roof Edge)			Interior Dimensions (Wall to Wall)			Door Opening	
			Width	Depth	Height	Width	Depth	Height	Width	Height
6' x 3'	17 Sq. Ft.	66 Cu. Ft.	67 5/8"	39 1/4"	52 1/2"	65 11/16"	36 1/2"	51 1/2"	57 11/16"	48 3/4"
1,8 m x 0,9 m	1,6 m <sup>2</sup>	1,9 m <sup>3</sup>	171,8 cm	100,0 cm	133,4 cm	166,8 cm	92,7 cm	130,8 cm	146,5 cm	123,8 cm

\* See Inside for Detailed Safety Information.

# Manuel de l'utilisateur et guide d'assemblage



**Taille de la base** 70.38" x 28.25"  
178,8 cm x 71,8 cm

## DIMENSIONS DU COFFRE

Taille † approx.	Zone d'entreposage		Dimensions extérieures (de bordure de toit à bordure de toit)			Dimensions intérieures (de paroi à paroi)			Ouverture de porte	
			Largeur	Profondeur	Hauteur	Largeur	Profondeur	Hauteur	Largeur	Hauteur
6' x 3'	12 Sq. Ft.	47 Cu. Ft.	72"	29 5/8"	50 1/4"	67 5/8"	25 1/2"	48 1/4"	57 1/2"	42.5"
1,8 m x 0,9 m	1,1 m <sup>2</sup>	1,3 m <sup>3</sup>	182,9 cm	75,2 cm	127,6 cm	171,8 cm	64,8 cm	122,6 cm	146,1 cm	108,0 cm

† Dimension arrondie au pied le plus proche

\* Voir les informations de sécurité détaillées à l'intérieur.

# Manual del propietario e instrucciones de ensamblaje



**Tamaño básico** 70.38" x 28.25"  
178,8 cm x 71,8 cm

## DIMENSIONES DE LA UNIDAD

Tamaño † aproximado	Área de almacenaje		Dimensiones exteriores (borde a borde del techo)			Dimensiones interiores (pared a pared)			Abertura de la puerta	
			Ancho	Profundidad	Altura	Ancho	Profundidad	Altura	Ancho	Altura
6' x 3'	12 Sq. Ft.	47 Cu. Ft.	72"	29 5/8"	50 1/4"	67 5/8"	25 1/2"	48 1/4"	57 1/2"	42.5"
1,8 m x 0,9 m	1,1 m <sup>2</sup>	1,3 m <sup>3</sup>	182,9 cm	75,2 cm	127,6 cm	171,8 cm	64,8 cm	122,6 cm	146,1 cm	108,0 cm

† Las medidas están redondeadas en pies

\* Consulte en el interior para obtener la seguridad de información detallada.

# Pflege- & Montageanleitung



**Bodenabmessungen** 70.38" x 28.25"  
178,8 cm x 71,8 cm

## ABMESSUNGEN

Ungefähre † Größe	Lagerfläche		Außenabmessungen (Dachkante zu Dachkante)			Innenabmessungen (Wand zu Wand)			Türöffnung	
			Breite	Tiefe	Höhe	Breite	Tiefe	Höhe	Breite	Höhe
6' x 3'	12 Sq. Ft.	47 Cu. Ft.	72"	29 5/8"	50 1/4"	67 5/8"	25 1/2"	48 1/4"	57 1/2"	42.5"
1,8 m x 0,9 m	1,1 m <sup>2</sup>	1,3 m <sup>3</sup>	182,9 cm	75,2 cm	127,6 cm	171,8 cm	64,8 cm	122,6 cm	146,1 cm	108,0 cm

† Angaben auf ganze Fuß gerundet

\* Detaillierte Sicherheitsinformationen im Inneren.

## CAUTION / ATTENTION / PRECAUCIONES/ VORSICHT

EN,FR,SP,GE-04HN

- Care must be taken when handling various pieces of your building since many contain sharp edges.
- Faire preuve de précaution pour manipuler les différentes pièces de l'abri car elles présentent de nombreux bords coupants.
- Tenga cuidado al manipular las diferentes piezas de la estructura ya que pueden tener bordes filosos.
- Verschiedene Teile Ihres Schuppens müssen vorsichtig gehandhabt werden, denn viele haben scharfe Kanten.

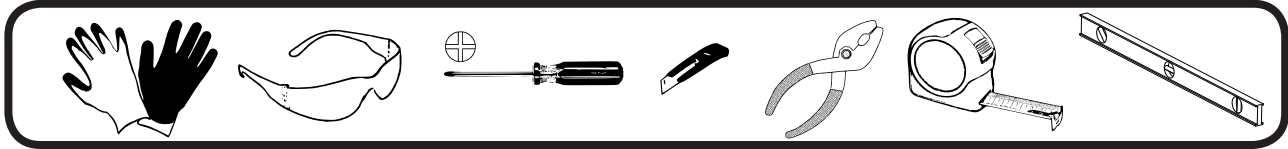

- Do NOT attempt to assemble your building before double checking that you have all the parts indicated in the parts lists. Any building left partially assembled may be seriously damaged by even light winds.
- Ne PAS tenter d'assembler l'abri avant d'avoir vérifié la présence de toutes les pièces figurant dans la liste des pièces. Tout abri laissé partiellement assemblé peut être gravement endommagé par des vents même légers.
- NO trate de montar la estructura antes de verificar que tenga todas las piezas indicadas en la lista de piezas. Cualquier estructura sin terminar puede ser dañada seriamente incluso por vientos ligeros.
- Versuchen Sie NICHT, Ihren Schuppen an einem windigen Tag aufzustellen. Die großen, flächigen Bauteile könnten wie ein Segel vom Wind erfasst und herumgeschleudert werden, was die Aufstellarbeiten erschwert und gefährlich macht.
- Do NOT attempt to assemble your building on a windy day. The large panels can catch the wind like a "sail", making construction difficult and unsafe. **Watch the Weather Closely**
- Ne PAS tenter d'assembler l'abri en présence de vent. Les grands panneaux peuvent se comporter comme une voile et « battre » au vent, rendant la construction difficile et dangereuse. **Suivre la météo avec attention**
- NO trate de montar la estructura en un día ventoso. Los paneles grandes pueden atrapar el viento como una "vela", lo que hace que sean llevados por el viento, lo que, a su vez, hace que la construcción sea difícil e insegura. **Observe el clima atentamente**
- Versuchen Sie NICHT, Ihren Schuppen zu montieren, bevor Sie sich nochmals vergewissert haben, dass Sie alle in der Teilleiste. Ein nur teilweise montiert zurückgelassener Schuppen kann bereits durch leichten Wind schwer beschädigt werden.
- Keep children and pets away from the worksite during construction and until the building is completely assembled. This will help avoid distractions and any accidents which may occur.
- Tenir les enfants et les animaux domestiques à l'écart du chantier durant la construction et jusqu'à ce que l'abri soit complètement assemblé. Cela évite les distractions et les accidents potentiels.
- No permita entrar a niños ni animales domésticos en el lugar de trabajo durante la construcción y hasta que la estructura esté completamente montada. Esto ayudará a evitar distracciones y cualquier accidente que pueda producirse.
- Halten Sie Kinder und Haustiere während der Montage und bis der Schuppen vollständig aufgestellt ist vom Aufstellplatz fern. Dies hilft, Ablenkungen und damit einhergehende Unfälle zu verhindern.
- NEVER concentrate your weight on the roof of the building.
- NE JAMAIS concentrer son propre poids sur le toit de l'abri.
- NUNCA concentre su peso en el techo de la estructura.
- Belasten Sie das Dach des Schuppens NIEMALS punktuell mit Ihrem Gewicht.
- Before assembling any parts, your base should be constructed and an anchoring system should be ready to use. Your building MUST be anchored to prevent wind damage.
- Avant de commencer à assembler des pièces, la base doit avoir été construite et le système d'ancrage doit être prêt à l'emploi. L'abri doit IMPÉRATIVEMENT être ancré pour éviter les dommages par le vent.
- Antes de montar cualquier pieza, debe estar construida la base y preparado el sistema de anclaje. La estructura DEBE estar anclada para evitar daños por vientos.
- Das Fundament sollte vor dem Zusammenbau der Teile gebaut und das Verankerungssystem nutzungsbereit sein. Ihr Schuppen MUSS verankert werden, um Schäden durch Wind zu verhindern.

- The best location is a level area with good drainage.
- Le meilleur emplacement sera une surface de niveau à bon drainage.
- El mejor lugar es un área nivelada con buen drenaje.
- Der bestmögliche Bauplatz ist eben mit einer guten Drainage.
- Allow enough space outside the building to be able to access the roof with a ladder.
- Laissez suffisamment d'espace à l'extérieur du bâtiment pour être en mesure d'accéder à la toiture avec une échelle.
- Deje suficiente espacio afuera del edificio para poder tener acceso al techo con una escalera.
- Es muß außerdem genügend Platz außerhalb des Gerätehauses vorgesehen werden, damit die Blechschrauben von außen aus verschraubt werden können.
- **Use Teamwork:** Two or more people are required to assemble your building.
- **Travailler en équipe:** Deux personnes ou plus sont nécessaires pour assembler l'abri.
- **Trabaje en equipo:** Se necesitan dos o más personas para ensamblar su cobertizo.
- **Arbeiten Sie im Team:** Mindestens zwei Personen werden für die Montage des Gerätehauses benötigt.

**CARE & MAINTENANCE / SOINS ET ENTRETIEN / PROTECCIÓN Y CONSERVACIÓN/  
PFLEGE & INSTANDHALTUNG**

- DO NOT use power washing to clean your shed.
- NE PAS utiliser de jet sous haute pression pour nettoyer l'abri.
- NO utilice hidrolavadora para limpiar el cobertizo.
- Reinigen Sie Ihren Schuppen NICHT mit dem Hochdruckreiniger.
- Combustibles and corrosives must be stored in air tight containers designed for chemical and/or combustible storage. Corrosive chemicals such as fertilizers, pesticides and herbicides should be cleaned off the interior and exterior surfaces immediately. Rust caused by chemical damage is not covered by the warranty.
- Les matières combustibles et corrosives doivent être entreposées dans des contenants étanches à l'air conçus pour l'entreposage de produits chimique et/ou combustibles. Les produits chimiques corrosifs tels que les engrais, pesticides et herbicides doivent immédiatement être nettoyés des surfaces intérieures et extérieures. La rouille causée par des produits chimiques n'est pas couverte par la garantie.
- Los combustibles y productos corrosivos deben guardarse en contenedores herméticos diseñados para almacenamiento de químicos o combustibles. Se deben limpiar inmediatamente los químicos corrosivos, como fertilizantes, pesticidas y herbicidas, de las superficies interiores y exteriores. El óxido causado por daños químicos no está cubierto por la garantía.
- Brennbare und ätzende Stoffe müssen in luftdichten Behältern gelagert werden, die zur Lagerung von Chemikalien und/oder Brennstoffen vorgesehen sind. Ätzende Chemikalien wie z. B. Dünger, Insektenvernichter und Unkrautvernichter sollten sofort von den Innen- und Außenflächen abgewischt werden. Durch die Lagerung von Chemikalien entstandener Rost wird nicht von der Gewährleistung abgedeckt.

**Rust protection precautions / Des mesures de protection contre la rouille /  
Las precauciones de protección contra el óxido/ Rostschutzmaßnahmen**

- Avoid nicking or scraping the coating surface, inside and out.
- Éviter d'entailler ou de rayer le revêtement de surface, à l'intérieur comme à l'extérieur.
- Evite dañar o raspar la capa protectora, por dentro y por fuera.
- Vermeiden Sie es, die Oberflächenbeschichtung an der Innen- und Außenseite zu beschädigen oder zu verkratzen.
- Keep roof, base perimeter and door free of debris.
- Nettoyer le toit, le pourtour de la base et les rails de porte de tous débris.
- Mantenga el techo, el perímetro de la base y los rieles de la puerta sin desechos.
- Halten Sie das Dach, den Bodenbereich und die Türführungen stets frei von Verunreinigungen.
- Touch up scrapes or nicks and any area of visible rust as soon as possible.
- Retoucher les entailles et égratignures et toute surface de rouille visible dès que possible.
- Retoque las raspaduras o las muescas y cualquier área de todo óxido visible lo más pronto posible.
- Bessern Sie Kratzer oder Beschädigungen und alle Bereiche mit sichtbarem Rost so schnell wie möglich aus.

# HARDWARE LIST / LISTE DE LA VISSERIE

For missing or damaged parts contact Customer Service. Do not return to store.

Key No.	Part No.	Qty.	✓ List
1	Lj-34	92	
2	Lj-35	146	
3	Lj-36	62	
4	Lj-37	12	
5	Lj-38	10	
6	Lj-39	3	
7	Lj-40	6	
8	Lj-41	2	

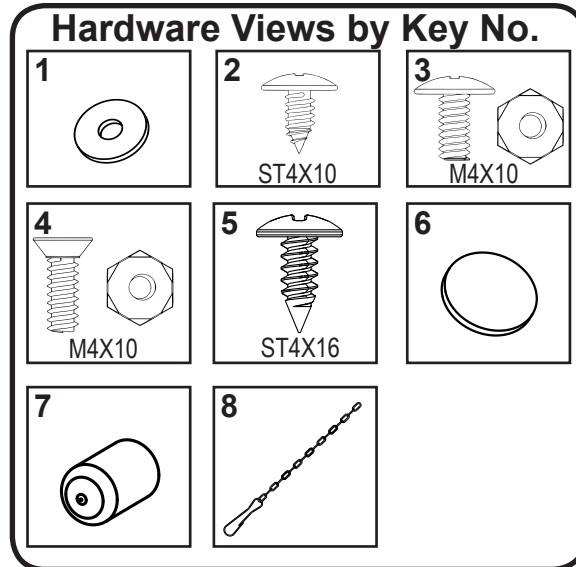

Si des pièces manquent ou sont endommagées, s'adresser au Service après-vente. Ne rien renvoyer au magasin.

Rep	Réf. pièce	Qté	✓
1	Lj-34	92	
2	Lj-35	146	
3	Lj-36	62	
4	Lj-37	12	
5	Lj-38	10	
6	Lj-39	3	
7	Lj-40	6	
8	Lj-41	2	

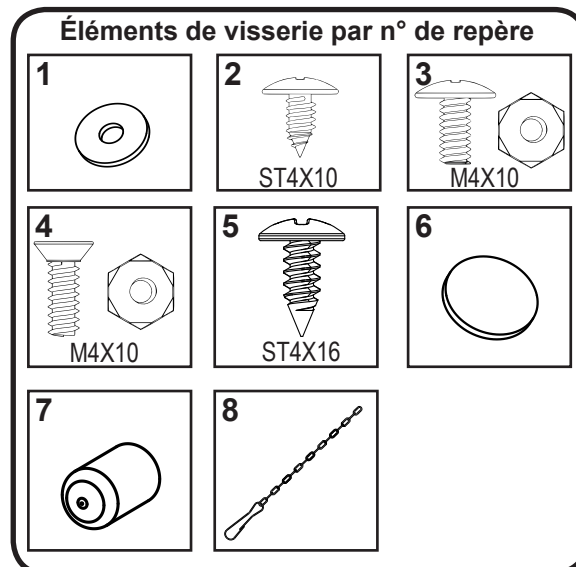

# LISTA DE PIEZAS / KLEINTEILELISTE

Si hay piezas faltantes o dañadas, comuníquese con el Servicio de Atención al Cliente. No devuelva el producto a la tienda.

N.º de referencia	N.º de pieza	Cant.	✓ Lista
1	Lj-34	92	
2	Lj-35	146	
3	Lj-36	62	
4	Lj-37	12	
5	Lj-38	10	
6	Lj-39	3	
7	Lj-40	6	
8	Lj-41	2	

**Vistas de los tornillos por n.º de referencia**

Wenden Sie sich bei fehlenden oder beschädigten Teilen an den Kundendienst. Wenden Sie sich nicht an den Händler.

Lfd. Nr.	Art.-Nr.	Menge	✓ Vorhanden
1	Lj-34	92	
2	Lj-35	146	
3	Lj-36	62	
4	Lj-37	12	
5	Lj-38	10	
6	Lj-39	3	
7	Lj-40	6	
8	Lj-41	2	

**Ansichten der Kleinteile nach Lfd. Nr.**

# PARTS LIST / LISTE DES PIÈCES / ARTÍCULOS DE FERRETERÍA / TEILELISTE











EN,FR,SP,GE-07HT

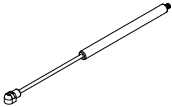
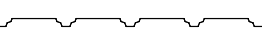
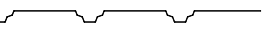
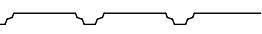

Key No. Rep. N.º de referencia Lfd. Nr.	Part No. Réf. pièce N.º de pieza Art.-Nr.	Qty. Qté Cant. Menge	Part Views Profils de pièces Vistas desde un extremo Vor-handen
1	Lj-1	1	
2	Lj-2	1	
3	Lj-3	2	
4	T-F	4	
5	Lj-4	1	
6	Lj-4a	1	
7	Lj-5	2	
8	Lj-6	2	
9	Lj-7	1	
10	Lj-8	1	
11	Lj-9	1	
12	Lj-9a	1	
13	Lj-10	1	
14	Lj-10a	1	

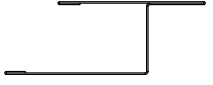
Key No. Rep. N.º de referencia Lfd. Nr.	Part No. Réf. pièce N.º de pieza Art.-Nr.	Qty. Qté Cant. Menge	Part Views Profils de pièces Vistas desde un extremo Vor-handen
15	Lj-11	1	
16	Lj-11a	1	
17	Lj-12	1	
18	Lj-12a	1	
19	Lj-13	2	
20	Lj-14	2	
21	Lj-14a	2	
22	Lj-15	1	
23	Lj-15a	1	
24	Lj-16	1	
25	Lj-17	1	
26	Lj-17a	1	
27	Lj-18	1	
28	Lj-19	1	

# PARTS LIST / LISTE DES PIÈCES / ARTÍCULOS DE FERRETERÍA / TEILELISTE

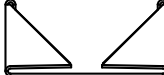
EN,FR,SP,GE-08HT

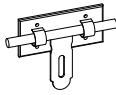
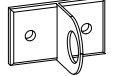
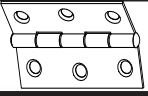
Key No. Rep. N.º de referencia Lfd. Nr.	Part No. Réf. pièce N.º de pieza Art.-Nr.	Qty. Qté Cant. Menge	Part Views Profils de pièces Vistas desde un extremo Vor-handen
29	Lj-20	1	
30	Lj-20a	1	
31	Lj-21	2	
32	Lj-14b	2	
33	Lj-14c	2	
34	Lj-22	2	
35	Lj-23	1	
36	Lj-23a	1	
37	Lj-24	2	
38	Lj-25	1	
39	Lj-26	1	
40	Lj-27	2	
41	Lj-27a	2	
42	Lj-28	4	

Key No. Rep. N.º de referencia Lfd. Nr.	Part No. Réf. pièce N.º de pieza Art.-Nr.	Qty. Qté Cant. Menge	Part Views Profils de pièces Vistas desde un extremo Vor-handen
43	Lj-29	1	
44	Lj-30	1	
45	Lj-31	1	
46	Lj-32	7	
47	Lj-33	2	



ASSEMBLY BY KEY NO. / PIÈCES PAR N° DE REPÈRE /  
MONTAJE POR N.º DE REFERENCIA / MONTAGE NACH LFD. NR.

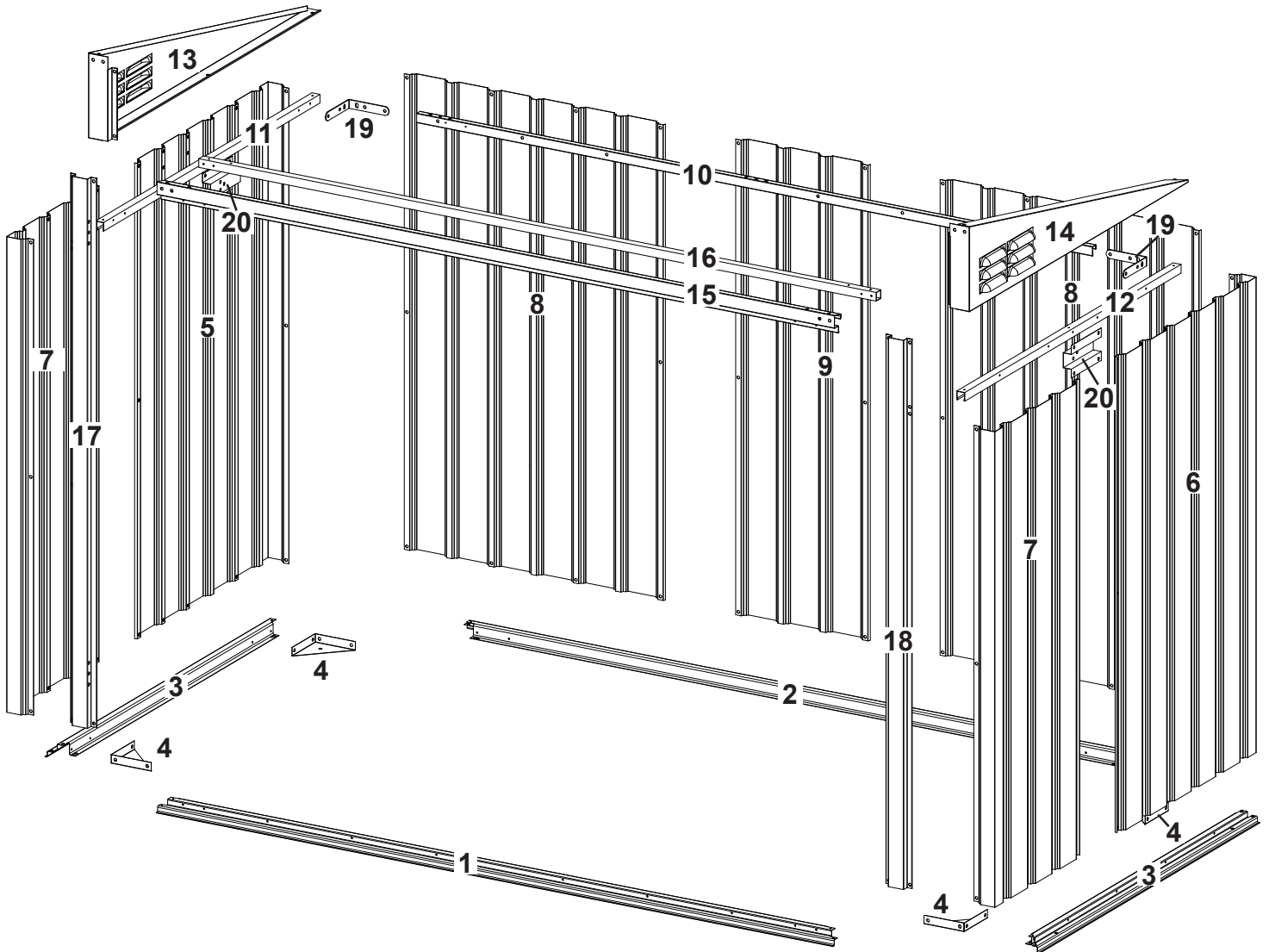

**ASSEMBLY BY KEY NO. / PIÈCES PAR N° DE REPÈRE /  
MONTAJE POR N.º DE REFERENCIA / MONTAGE NACH LFD. NR.**

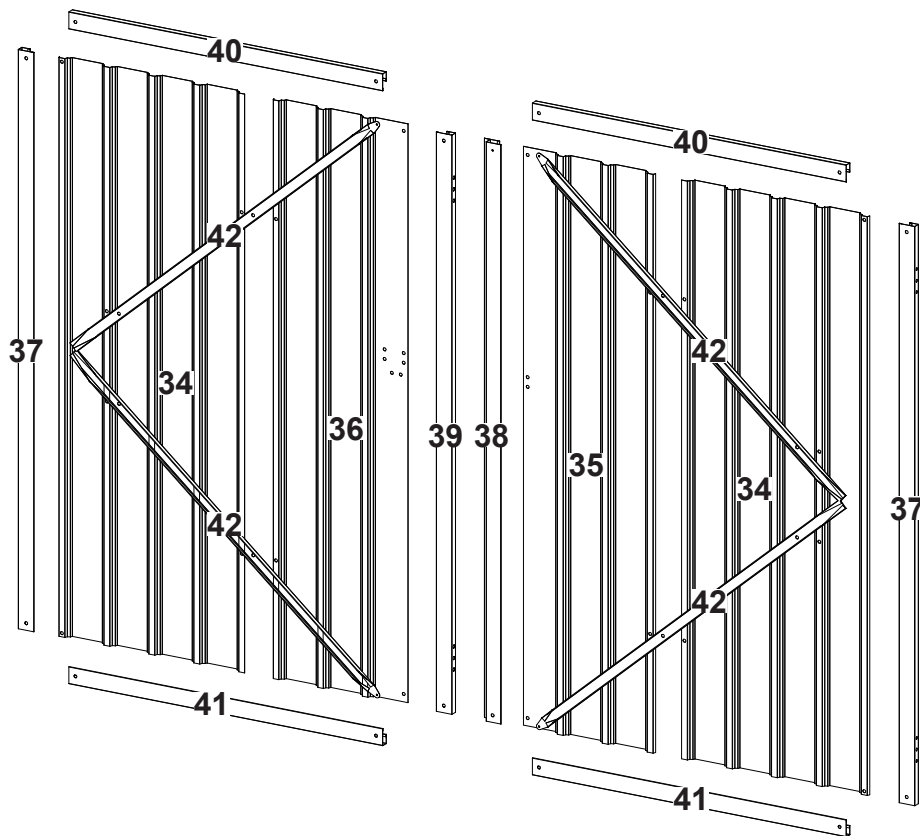
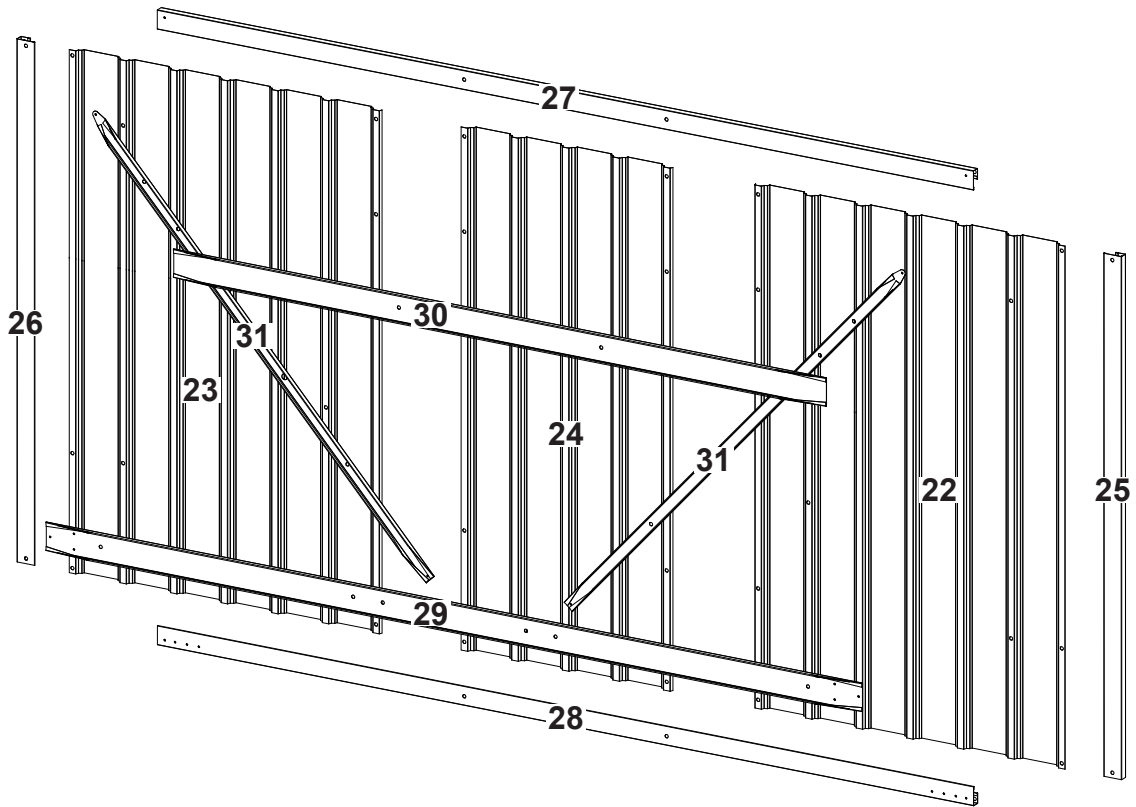

# CONSTRUCTING A BASE...

## OPTION 1: Directly on ground (earth)

Assemble your building directly on level ground (grass, dirt, rock, sand, etc.).

## OPTION 2: Wood Platform

If you decide to build your own base, be sure to select the appropriate materials.

These are the recommended materials for your base:

- 2 x 4's (38 mm x 89 mm) Pressure Treated Lumber • 5/8" (15,5 mm) 4 x 8 (1220 mm x 2440 mm) Plywood-exterior grade
- 10 & 4 penny Galvanized Nails • Concrete Blocks (optional)

**NOTE:** Pressure Treated Lumber must not be used where it will make contact with your storage building. The properties of Pressure Treated Lumber will cause accelerated corrosion. **If Pressure Treated Lumber comes in contact with your storage building your warranty will be voided.**

The platform should be level and flat (free of bumps, ridges etc.) to provide good support for the building. The necessary materials may be obtained from your local lumber yard.

To construct the base follow instructions and diagram.

- Construct frame (using 10 penny galvanized nails)
- Measure 16"/24" (40,6 cm/61,0 cm) sections to construct inside frame (see diagram)
- Secure plywood to frame (using 4 penny galvanized nails)

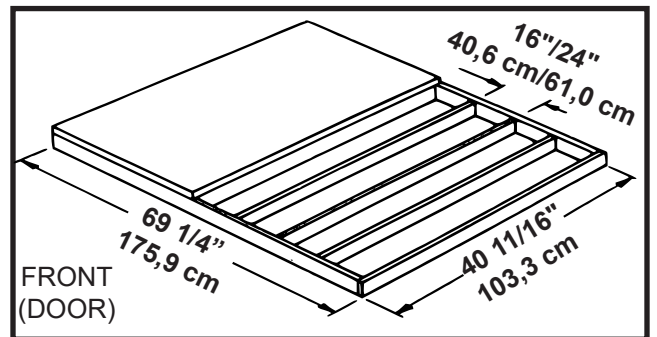

Note: Platform/Slab will extend 9/16" (1,4 cm) beyond floor frame on all four sides. Seal this 9/16" (1,4 cm) of wood with a roofing cement (not included), or bevel this 9/16" (1,4 cm) of concrete when pouring, for good water drainage.

## OPTION 3: Concrete Slab

The slab should be at least 4" (10,2 cm) thick. It must be level and flat to provide good support for the frame.

The following are the recommended materials for your base.

- 1 x 4's (19 mm x 89 mm) (will be removed once the concrete cures)
- Concrete • Sheet of 6 mil plastic
- We recommend for a proper strength concrete to use a mix of:  
1 part cement • 3 parts pea sized gravel • 2 1/2 parts clean sand

Prepare the Site/Construct a Base

1. Dig a square, 6" (15,2 cm) deep into the ground (remove grass).
2. Fill up to 4" (10,2 cm) in the square with gravel and tamp firm.
3. Cover gravel with a sheet of 6 mil plastic.
4. Construct a wood frame using four planks of 1x4 (19 mm x 89 mm) lumber.
5. Pour in concrete to fill in the hole and the frame giving a total of 4" (10,2 cm) thick concrete. Be sure surface is level.

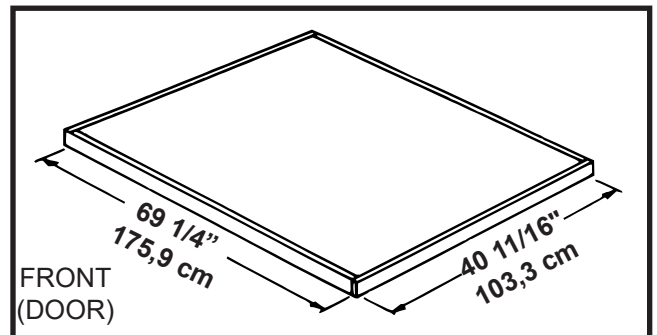

Note: Finished Slab dimensions, with lumber removed.

# CONSTRUIRE UNE BASE...

## OPTION 1 : À MÊME LE SOL (TERRE)

Monter l'abri directement sur un sol de niveau (herbe, terre, pierre, sable, etc.).

## OPTION 2 : PLATEFORME EN BOIS

Pour construire soi-même une base, veiller à choisir des matériaux appropriés.

Les matériaux recommandés pour la base sont les suivants :

• Montants 2 x 4 (38 mm x 89 mm) en bois traité sous pression • Panneaux 4 x 8 (1220 mm x 2440 mm) de 5/8" (15,5 mm) en contreplaqué pour extérieur • Clous galvanisé de 10d et 4d • Parpaings de béton (facultatif)

**REMARQUE :** Ne pas utiliser de bois traité sous pression aux points de contact avec l'abri. Le bois traité sous pression contribue à accélérer la corrosion. **Le contact de bois traité sous pression avec l'abri aura pour effet d'annuler la garantie.**

La plateforme doit être plate et de niveau (sans bosses, arêtes, etc.) afin d'offrir un bon support à l'abri. Les matériaux nécessaires peuvent s'obtenir auprès d'un fournisseur de bois d'œuvre local.

Pour construire la base, suivre les instructions et les schémas.

Construire le cadre (utiliser des clous galvanisés 10d)

Prévoir des baies de 16"/24" (40,6 cm/61,0 cm) à l'intérieur du cadre (voir le schéma)

Attacher le contreplaqué au cadre (avec des clous galvanisés 4d)

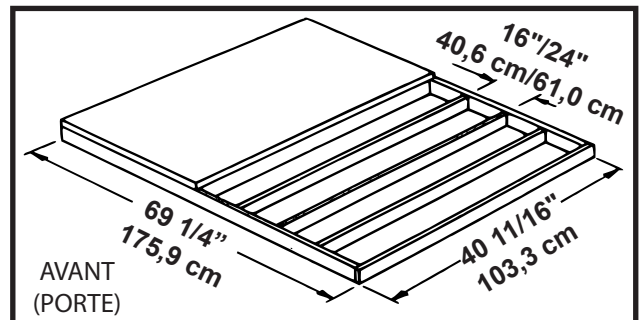

Remarque : La dalle ou plateforme dépasse de 9/16" (1,4 cm) au-delà du cadre de plancher sur les quatre côtés. Sceller la bande de bois de 9/16" (1,4 cm) avec une colle pour toiture (non fournie) ou couler la bordure de béton de 9/16" (1,4 cm) en biseau pour assurer un bon écoulement de l'eau.

## OPTION 3: DALLE EN BETON

La dalle doit avoir au moins 4" (10,2 cm) d'épaisseur. Elle doit être plane et de niveau afin d'offrir un bon support pour le cadre.

Les matériaux recommandés pour la base sont les suivants :

• Planches 1 x 4 (19 mm x 89 mm) (seront enlevés une fois que le béton a durci) • Béton • Membrane de plastique de 0,15 mm • Pour produire un béton de bonne résistance, le mélange préconisé est le suivant : • 1 volume de ciment • 3 volumes de gravillon • 2,5 volumes de sable propre

Préparer le terrain et construire la base

1. Creuser un carré de 6" (15,2 cm) de profondeur dans le sol (enlever l'herbe).
2. Remplir jusqu'à 4" (10,2 cm) du carré de gravillon et tasser fermement.
3. Couvrir le gravillon d'une membrane de plastique de 0,15 mm.
4. Assembler un coffrage en bois avec quatre planches de 1 x 4 (19 mm x 89 mm).
5. Couler le béton dans le trou et le coffrage sur une épaisseur totale de 4" (10,2 cm). S'assurer que la surface est de niveau.

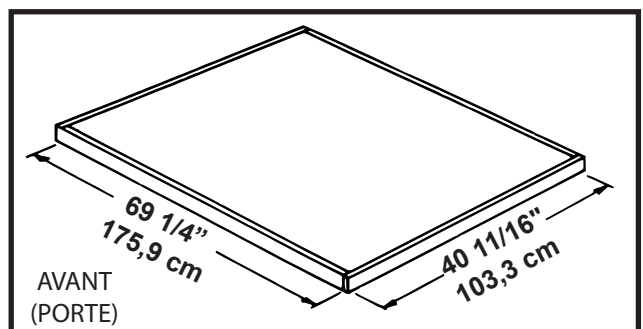

Remarque : dimensions finies de la dalle, sans le bois.

# CONSTRUIR UNA BASE...

## OPCIÓN 1: Directamente sobre el suelo (tierra)

Ensamble su cobertizo directamente sobre tierra firme (césped, tierra, roca, arena, etc.).

## OPCIÓN 2: Plataforma de madera

Si decide construir su propia base, asegúrese de elegir los materiales apropiados.

Estos son los materiales recomendados para su base:

• Madera tratada a presión de 38 mm x 89 mm (2 x 4) • Conglomerado de madera para exteriores de 15,5 mm x 1220 mm x 2440 mm (5/8" x 4 x 8) • Clavos galvanizados de 10 & 4 penny • Bloques de concreto (opcional)

**NOTA:** La madera tratada a presión no debe utilizarse en lugares donde haga contacto con la estructura de almacenamiento. Las propiedades de la madera tratada a presión acelerarán la corrosión. **Si la madera tratada a presión entra en contacto con la estructura de almacenamiento, se anulará su garantía.**

La plataforma debe estar nivelada y plana (libre de protuberancias, rugosidades, etc.) para ofrecer una buena base de sustento para el cobertizo. Puede obtener los materiales necesarios de su maderera local.

Para construir la base, siga las instrucciones y el diagrama.

Construya el entramado (utilizando los clavos galvanizados de 10 penny) Mida secciones de 40,6 cm/61,0 cm (16"/24") para construir el entramado interior (ver el diagrama)

Fije el conglomerado de madera al entramado (utilizando los clavos galvanizados de 4 penny)

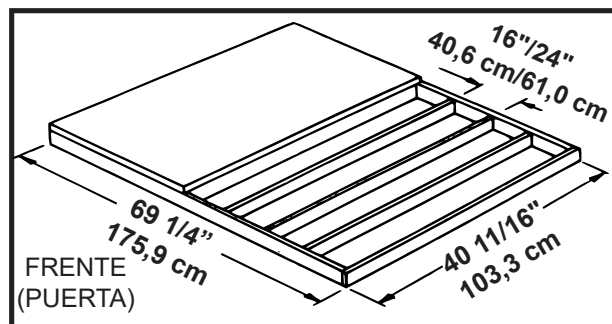

Nota: La plataforma o losa debe extenderse 1,4 cm (9/16") más allá del entramado del piso en los cuatro lados. Selle esta saliente con cemento para techado (no se incluye); o, si es de concreto, bisele esta parte saliente antes de que se seque a fin de tener un buen drenaje de agua.

## OPCIÓN 3: Losa de concreto

La losa debe tener un espesor mínimo de 10,2 cm (4"). Debe estar nivelada y plana para ofrecer una buena base de sustento para el entramado.

Se recomiendan los siguientes materiales para su base:

- Tirantes de madera de 19 mm x 89 mm (1 x 4) (que se retiran una vez que haya fraguado el concreto)
- Concreto • Lámina plástica de 0,15 mm
- Para lograr un concreto de buena resistencia, recomendamos una mezcla de: 1 parte de cemento • 3 partes de grava de tamaño pequeño • 2 partes y 1/2 de arena limpia

Prepare el sitio/Construya la base

1. Cave un cuadrado de 15,2 cm (6") de profundidad en la tierra (elimine el césped).
2. Llene dicho cuadrado hasta 10,2 cm (4") con grava y aprisione firmemente.
3. Cubra la grava con una lámina de plástico de 0,15 mm.
4. Construya un marco con 4 tirantes de madera de 19 mm x 89 mm (1 x 4).
5. Vierta el concreto para llenar el hueco y el marco, con un espesor total de 10,2 cm (4") de concreto. Asegúrese que la superficie esté nivelada.

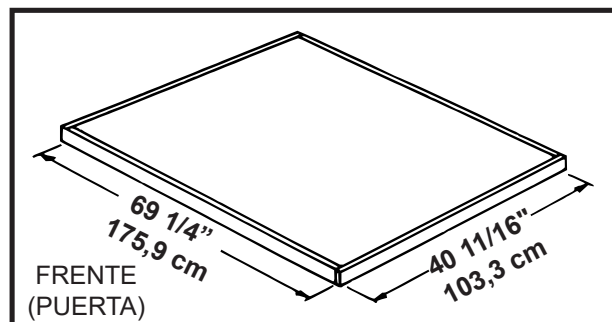

Nota: Las dimensiones de la losa terminada, con la madera retirada.

# BAU EINER BODENPLATTE ...

## MÖGLICHKEIT 1: Direkt auf dem Untergrund (Erde)

Bauen Sie Ihren Schuppen direkt auf ebenem Boden (Gras, Erde, Fels, Sand usw.).

## MÖGLICHKEIT 2: Plattform aus Holz

Wenn Sie Ihre eigene Bodenplatte bauen möchten, achten Sie darauf, geeignete Materialien auszuwählen.

Diese sind die empfohlenen Materialien für Ihre Bodenplatte:

- Kesseldruckimprägnierte Balken 38 mm x 89 mm
- Sperrholz für außen 15,5 mm x 1220 mm x 2440 mm
- Verzinkte Nägel 80 mm & 40 mm
- Betonsteine (optional)

**HINWEIS:** An Stellen, an denen es mit Ihrem Geräteschuppen in Kontakt kommen würde, darf kein kesseldruckimprägniertes Holz verwendet werden. Kesseldruckimprägniertes Holz hat Eigenschaften, die zu beschleunigter Korrosion führen. **Wenn kesseldruckimprägniertes Holz mit Ihrem Geräteschuppen in Kontakt kommt, wird Ihre Garantie ungültig.**

Die Plattform sollte flach und eben sein (frei von Unebenheiten, Graten usw.), damit sie gut als Fundament Ihres Schuppens dienen kann. Das notwendige Baumaterial erhalten Sie im Baumarkt.

**Folgen Sie beim Bau der Bodenplatte den Anweisungen und der Zeichnung.**

Bauen Sie den Rahmen (mit verzinkten Nägeln 80 mm)  
Messen Sie 40,6 cm/61,0 cm große Fächer aus, die Sie innerhalb des Rahmens bauen (siehe Zeichnung)  
Nageln Sie das Sperrholz auf den Rahmen (mit verzinkten Nägeln 40 mm)

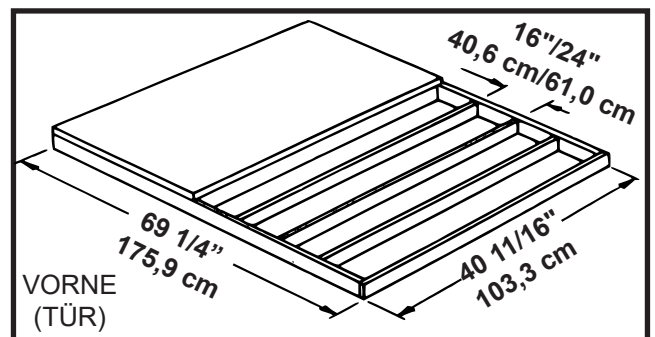

Hinweis: Die Plattform/Bodenplatte ragt auf allen vier Seiten 1,4 cm aus dem Bodenrahmen heraus. Versiegeln Sie diese 1,4 cm Holz mit einem Dachkleber (nicht im Lieferumfang enthalten) oder schrägen Sie diese 1,4 cm Beton beim Gießen für eine gute Drainage ab.

## MÖGLICHKEIT 3: Bodenplatte aus Beton

Die Bodenplatte sollte wenigstens 10,2 cm stark sein. Sie muss flach und eben sein, damit sie dem Rahmen ein gutes Fundament ist.

Diese sind die empfohlenen Materialien für Ihre Bodenplatte:

- Beton
- Kunststoffolie 0,15 mm
- Für ausreichend festen Beton empfehlen wir eine Mischung aus: 1 Teil Zement • 3 Teile Kies (erbgroß) • 2 1/2 Teile sauberer Sand

**Vorbereiten des Aufstellorts/bau einer Bodenplatte**

1. Geben Sie ein 15,2 cm tiefes Rechteck aus (Gras entfernen).
2. Füllen Sie das Rechteck bis zu 10,2 cm mit Kies und stampfen Sie ihn fest.
3. Decken Sie den Kies mit einer 0,15 mm starken Kunststoffolie ab.
4. Bauen Sie aus vier Brettern mit 19 mm x 89 mm Querschnitt einen Holzrahmen.
5. Füllen Sie das Loch und den Rahmen mit Beton aus, sodass der Beton insgesamt 10,2 cm stark ist. Achten Sie darauf, dass die Oberfläche eben ist.

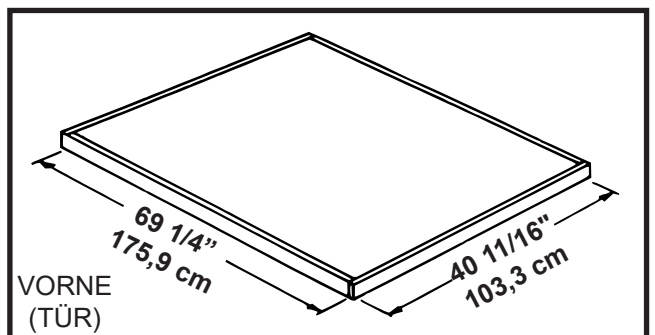

Hinweis: Abmessungen der fertigen Bodenplatte nach Entfernen der Verschalung.

# Step 1 / Étape 1 / Paso 1 / Schritt 1

You will need for this page:

Nécessaire pour cette page:

Usted necesitará para esta página:

Für diese Seite brauchen Sie:

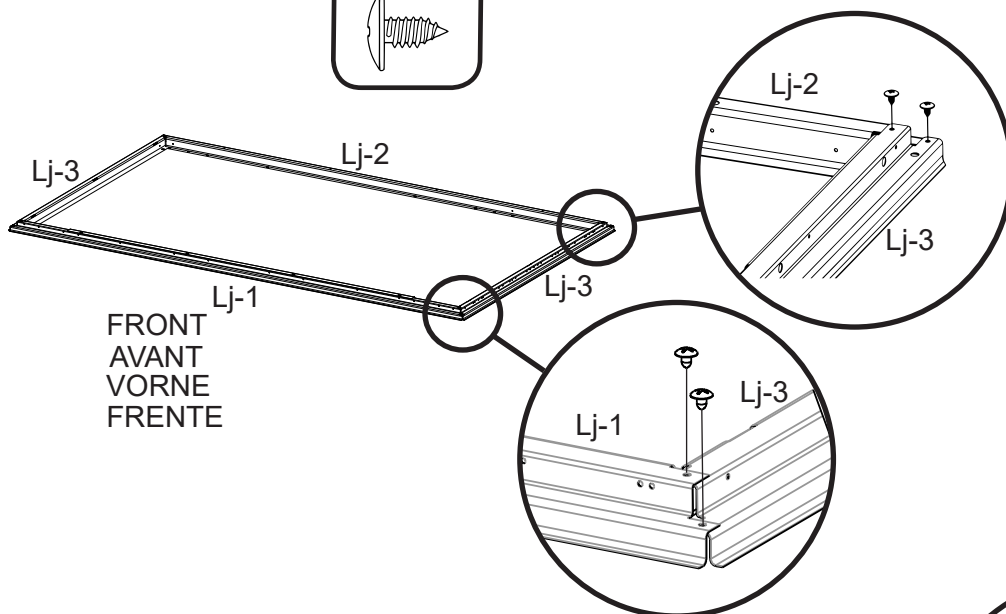
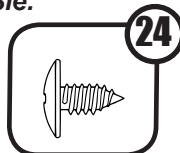
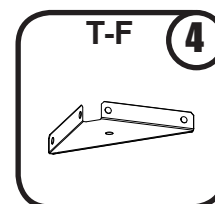
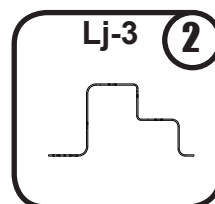
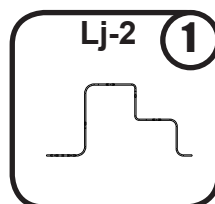
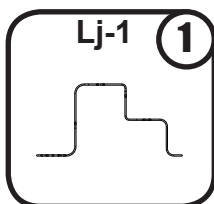

FRONT  
AVANT  
VORNE  
FRENTE

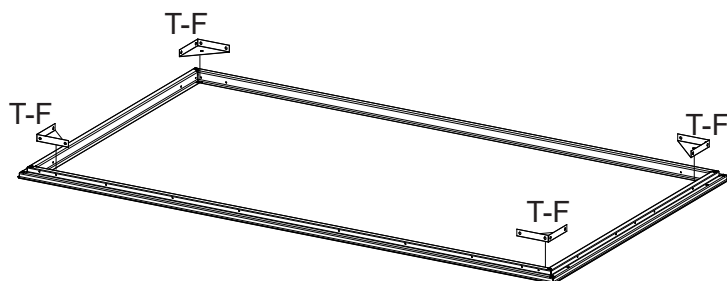

When diagonal measurements are equal, the Frame is square.

Mesurer les diagonales du cadre de plancher. Lorsqu'elles sont égales, le cadre de plancher est d'équerre.

Quando las medidas diagonales son iguales, el tirante está cuadrado.

Wenn die diagonalen Abmessungen gleich sind, ist der Rahmen rechtwinklig.

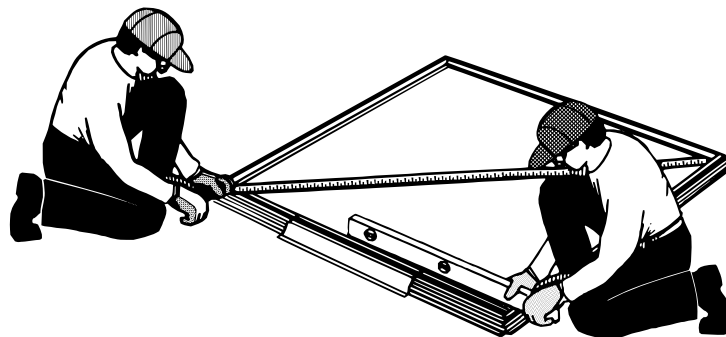

The Floor Frame must be BOTH square AND level or the holes will not line up properly.

Le cadre de plancher doit être À LA FOIS d'équerre et de niveau pour que les trous s'alignent correctement.

El tirante del piso debe estar TANTO cuadrado COMO nivelado o los orificios no se alinearán correctamente.

Der Bodenrahmen muss SOWOHL rechtwinklig ALS AUCH waagrecht sein. Andernfalls fluchten die Löcher nicht richtig.

# Step 2 / Étape 2 / Paso 2 / Schritt 2

You will need for this page:

Nécessaire pour cette page:

Usted necesitará para esta página:

Für diese Seite brauchen Sie:

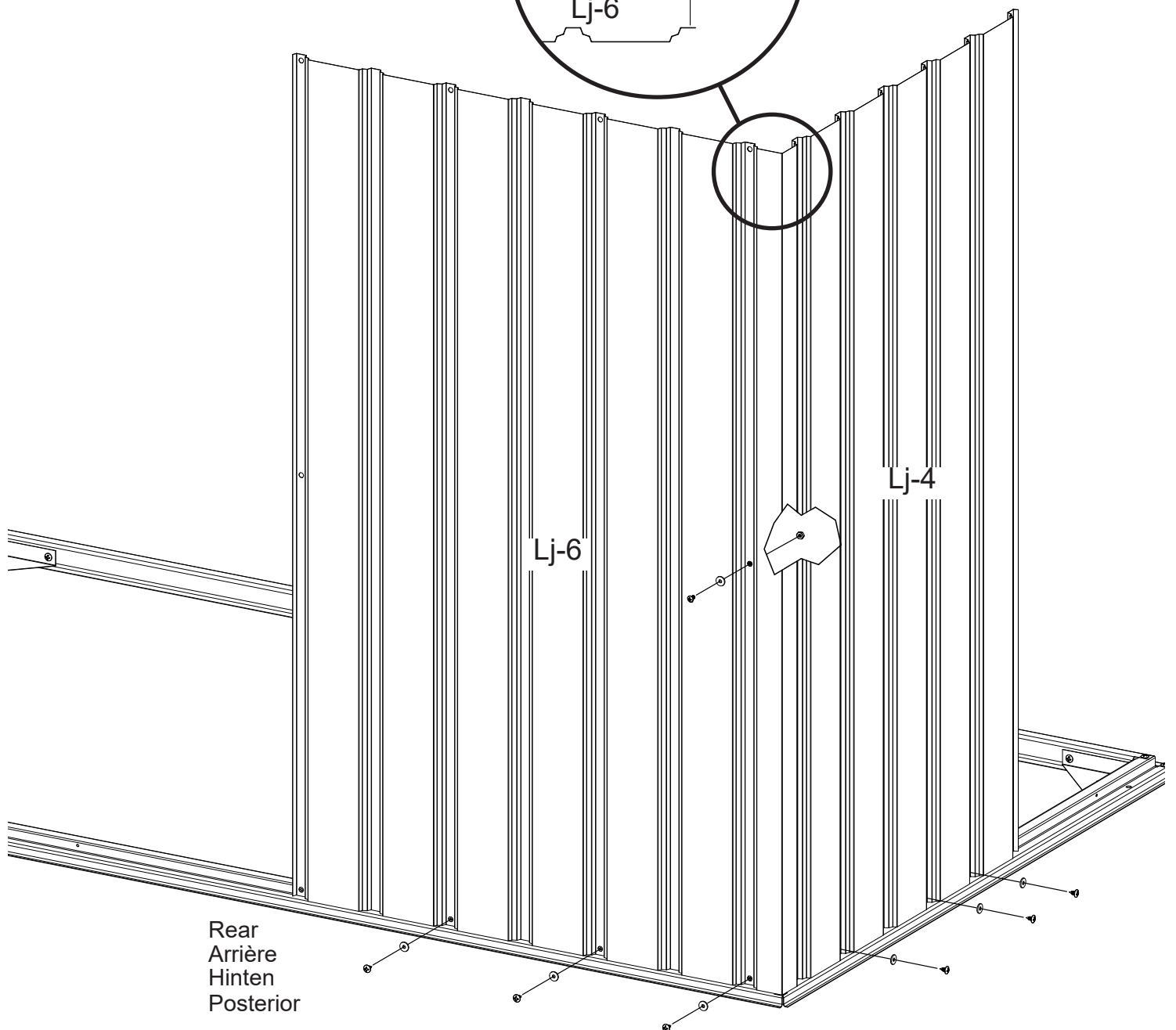
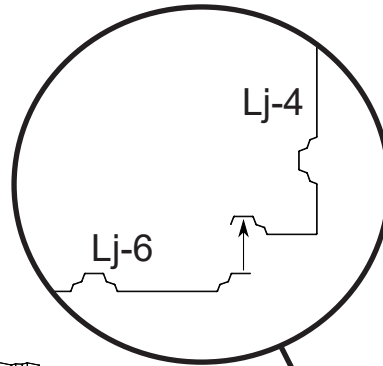
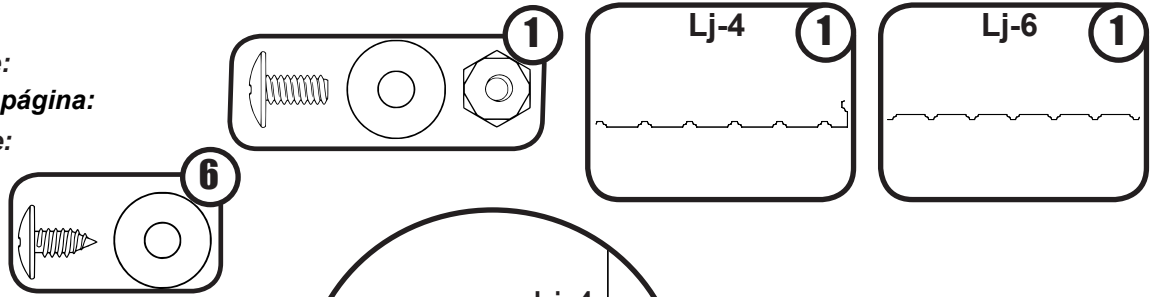



# Step 2 / Étape 2 / Paso 2 / Schritt 2

You will need for this page:

Nécessaire pour cette page:

Usted necesitará para esta página:

Für diese Seite brauchen Sie:

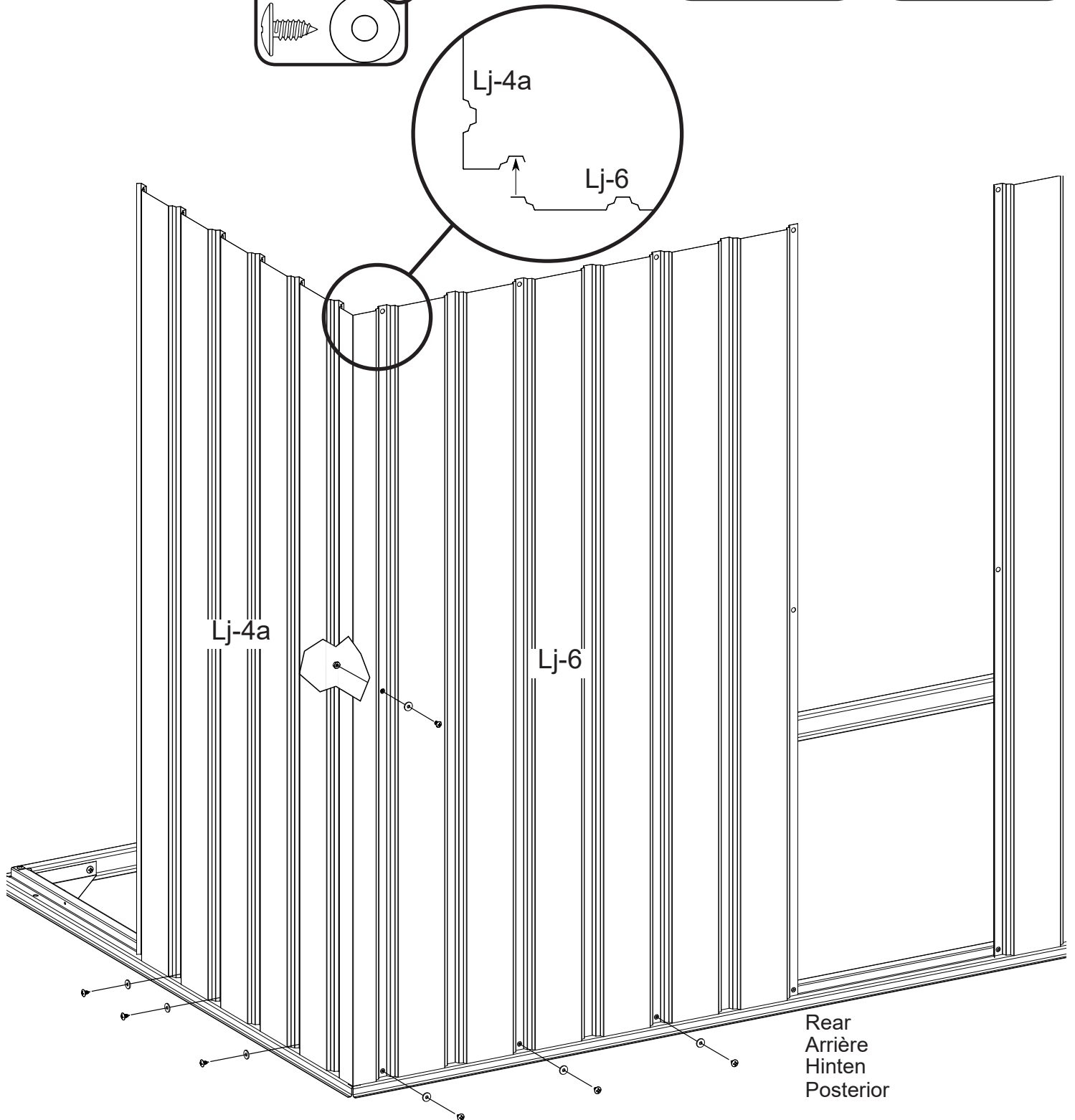
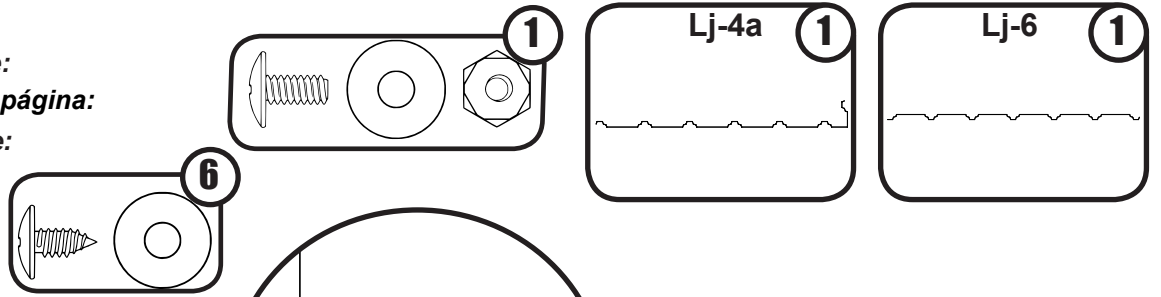

# Step 2 / Étape 2 / Paso 2 / Schritt 2

You will need for this page:

Nécessaire pour cette page:

Usted necesitará para esta página:

Für diese Seite brauchen Sie:

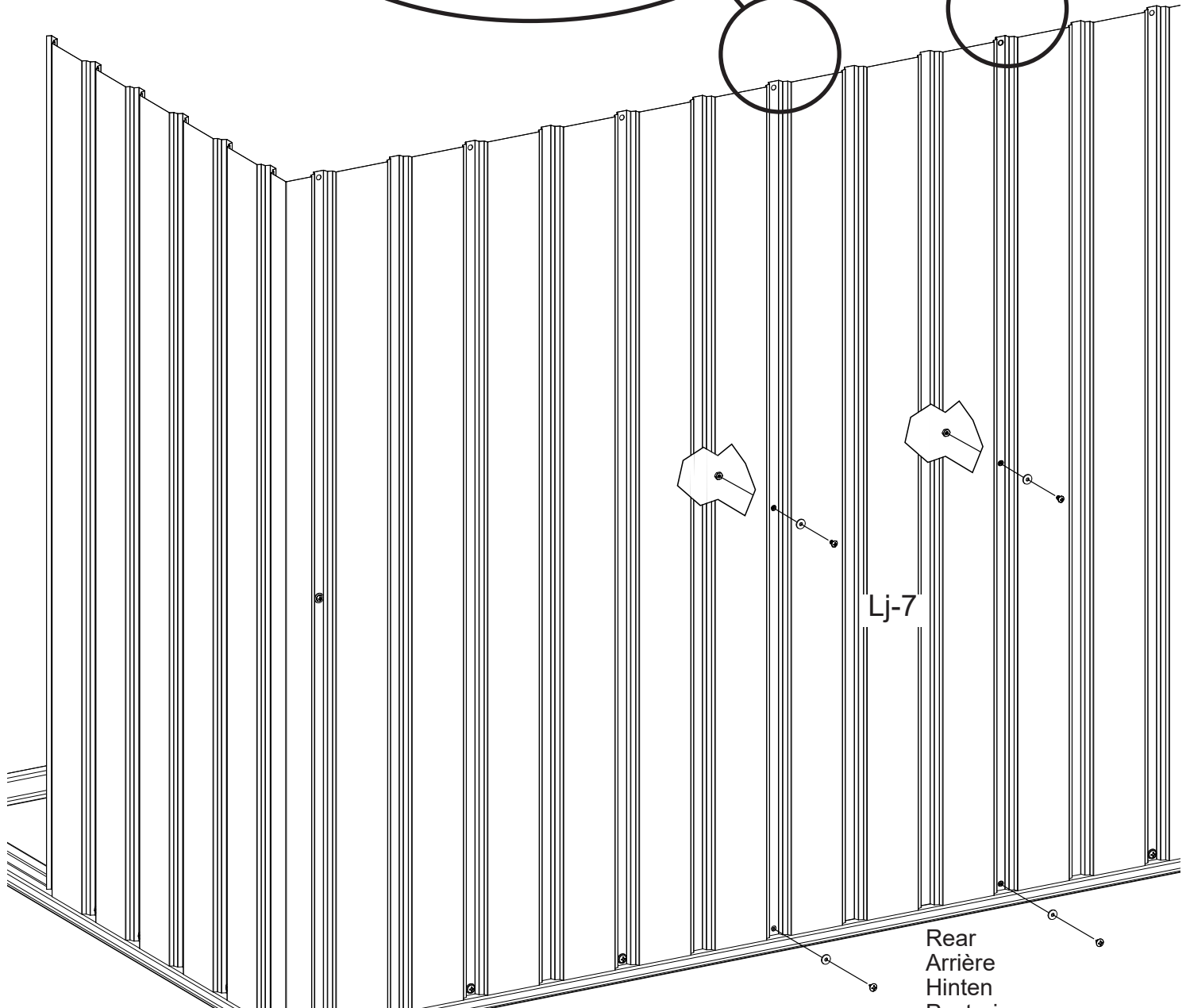
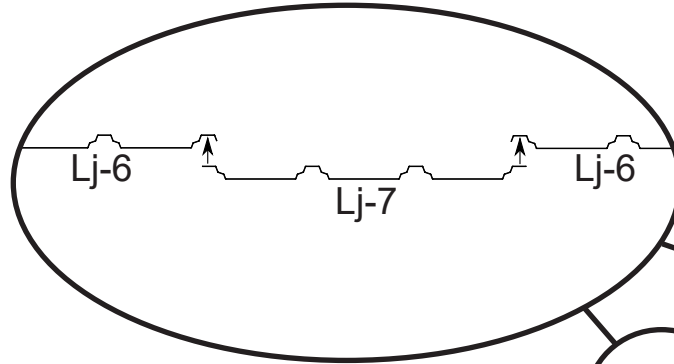
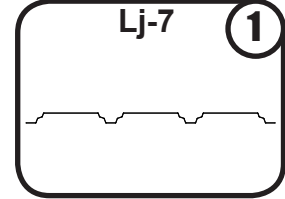
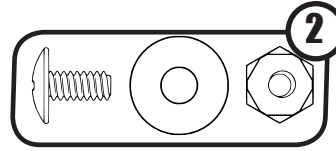
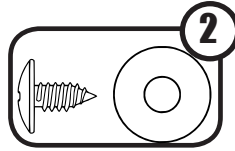

# Step 2 / Étape 2 / Paso 2 / Schritt 2

You will need for this page:

Nécessaire pour cette page:

Usted necesitará para esta página:

Für diese Seite brauchen Sie:

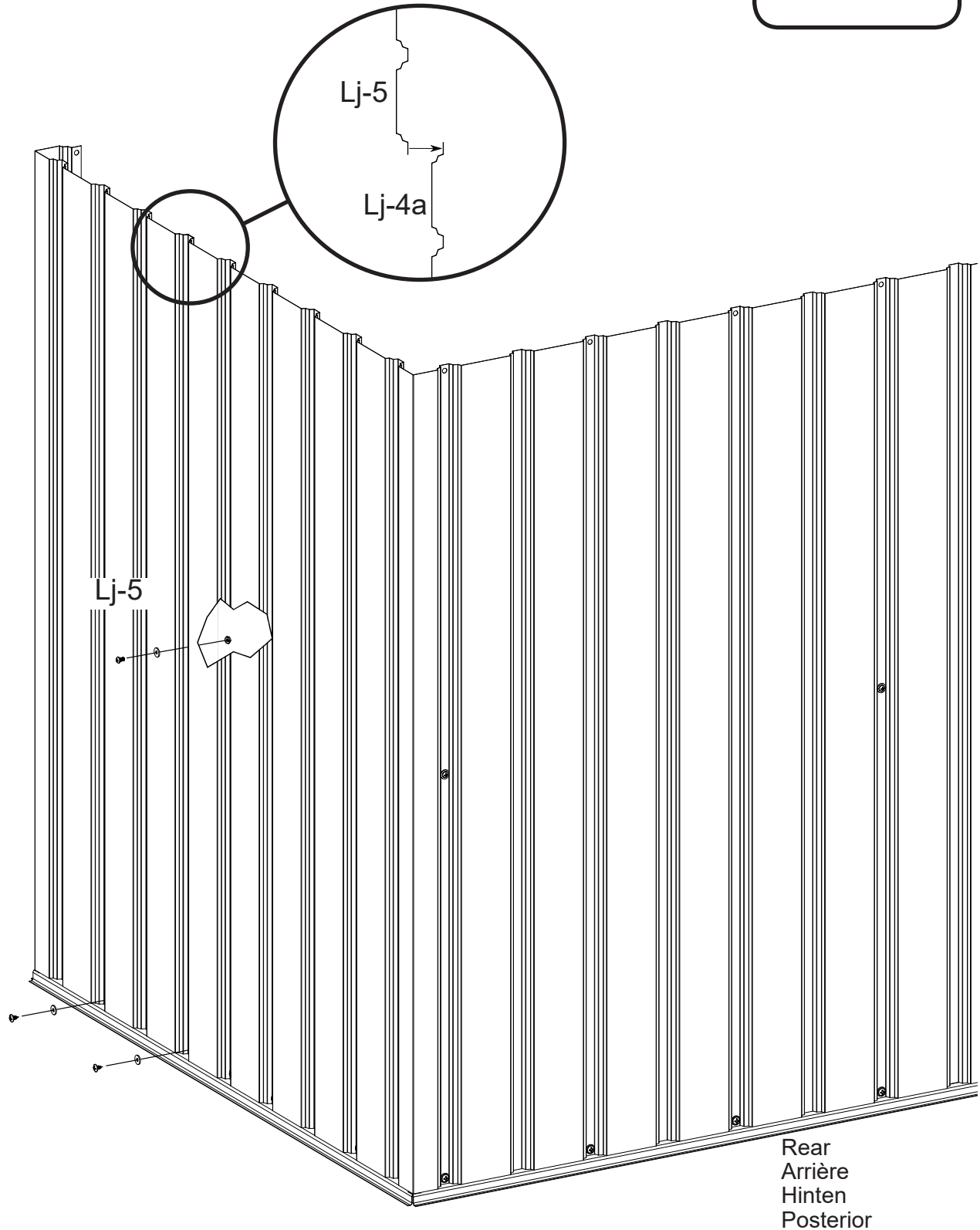
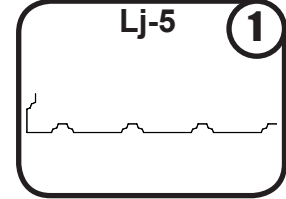
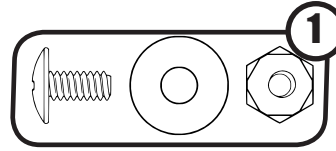
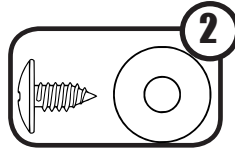

# Step 2 / Étape 2 / Paso 2 / Schritt 2

You will need for this page:

Nécessaire pour cette page:

Usted necesitará para esta página:

Für diese Seite brauchen Sie:

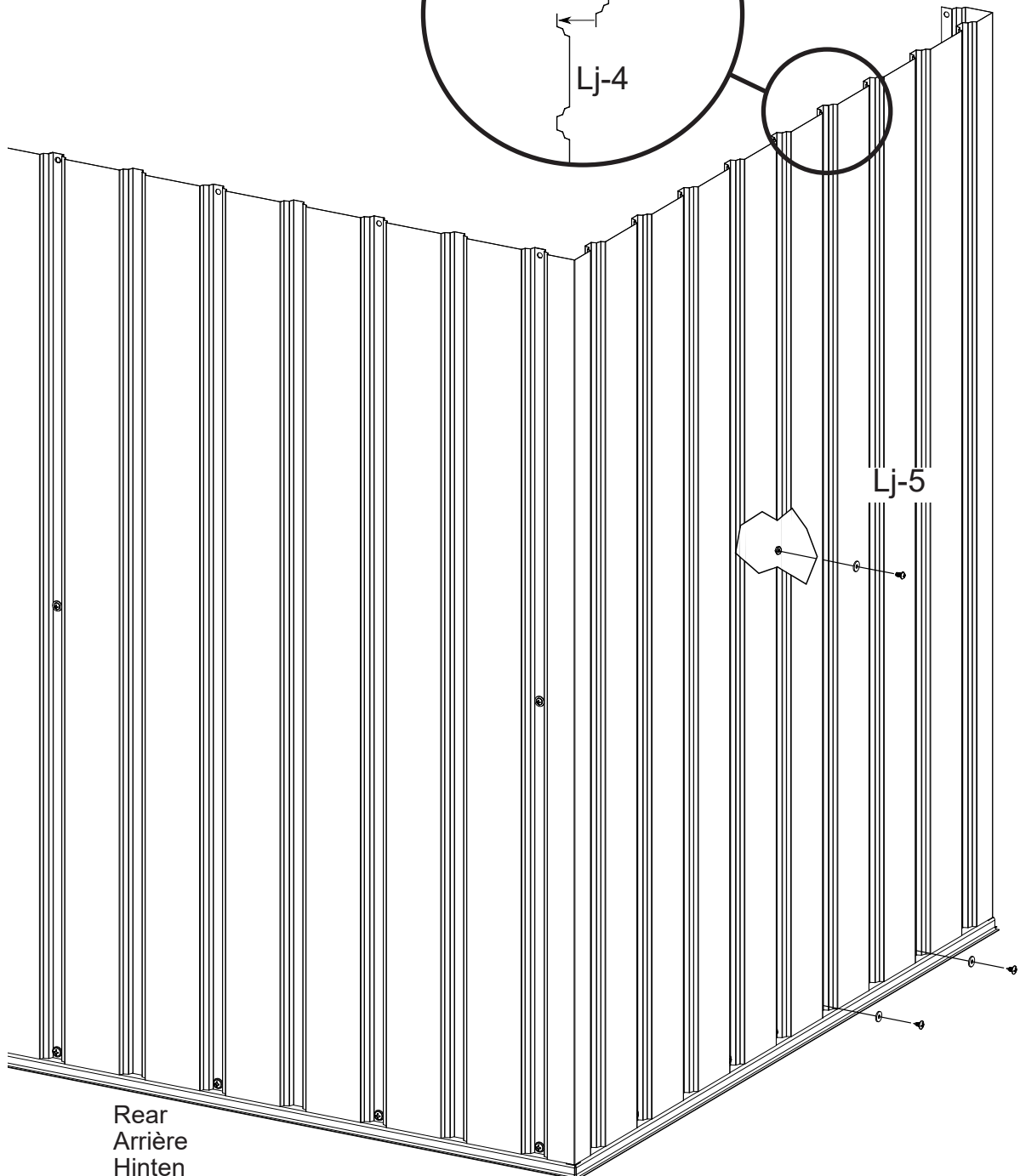
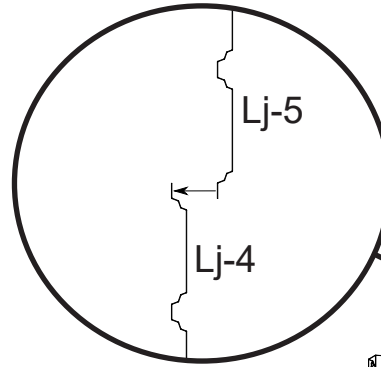
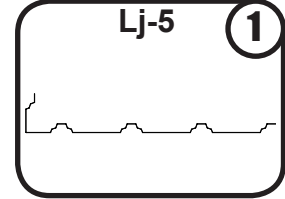
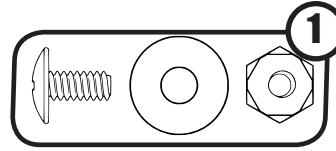
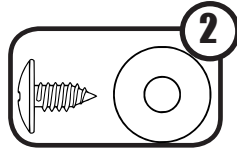

Rear  
Arrière  
Hinten  
Posterior

# Step 2 / Étape 2 / Paso 2 / Schritt 2

You will need for this page:

Nécessaire pour cette page:

Usted necesitará para esta página:

Für diese Seite brauchen Sie:

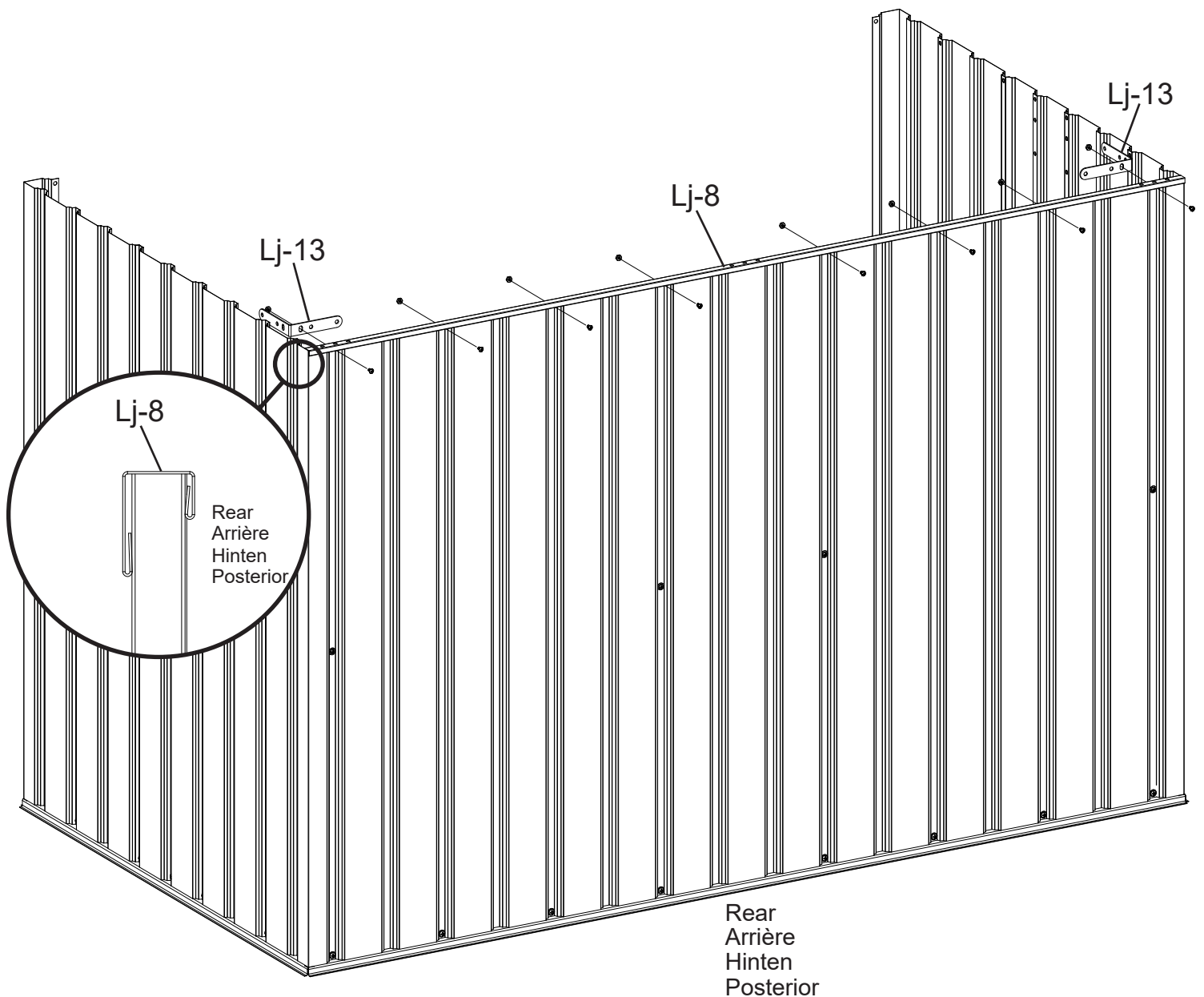
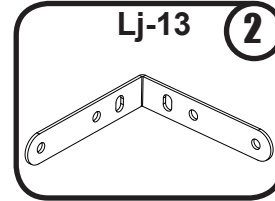
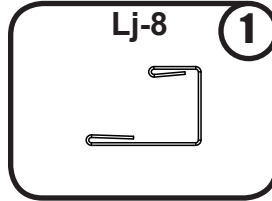
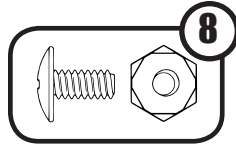

# Step 2 / Étape 2 / Paso 2 / Schritt 2

You will need for this page:

Nécessaire pour cette page:

Usted necesitará para esta página:

Für diese Seite brauchen Sie:

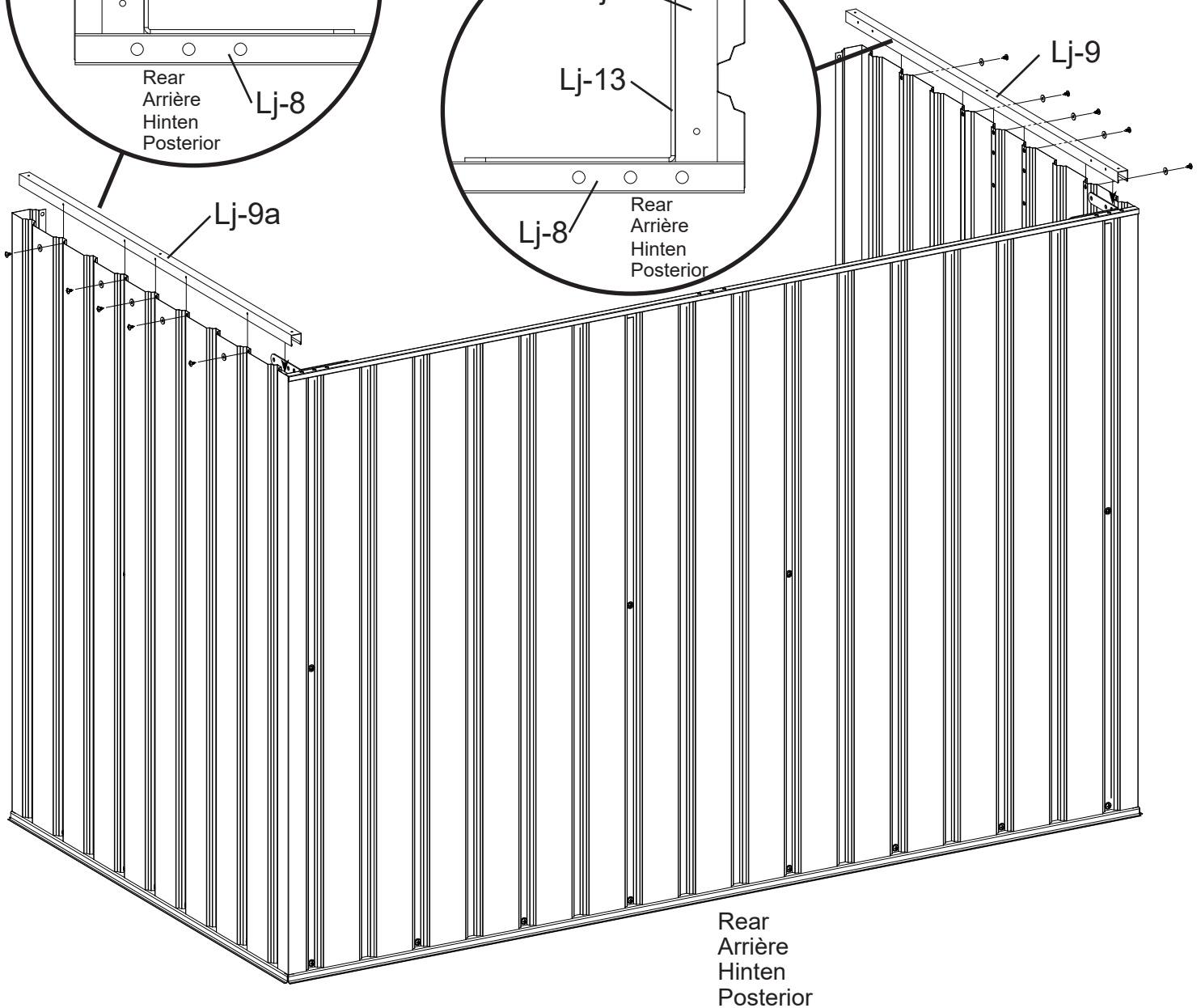
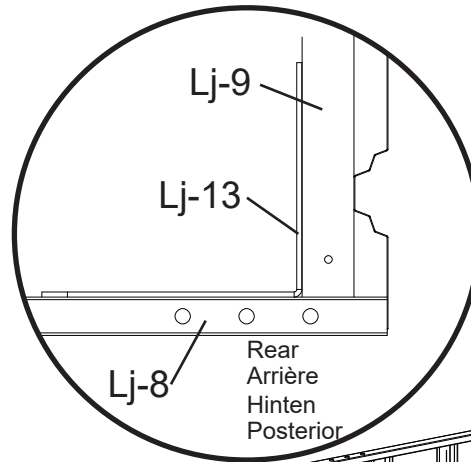
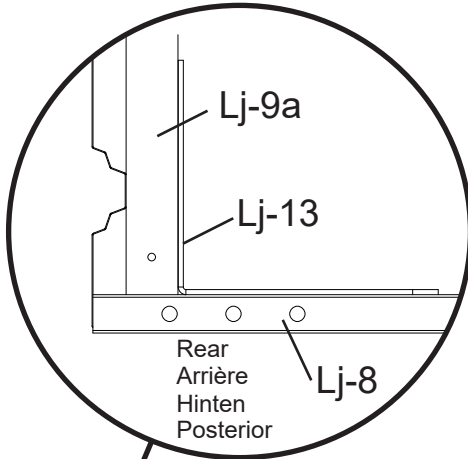
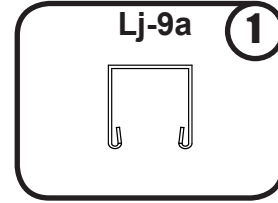
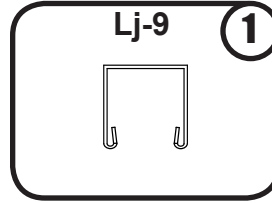
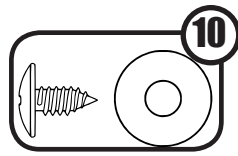

# Step 2 / Étape 2 / Paso 2 / Schritt 2

You will need for this page:

Nécessaire pour cette page:

Usted necesitará para esta página:

Für diese Seite brauchen Sie:

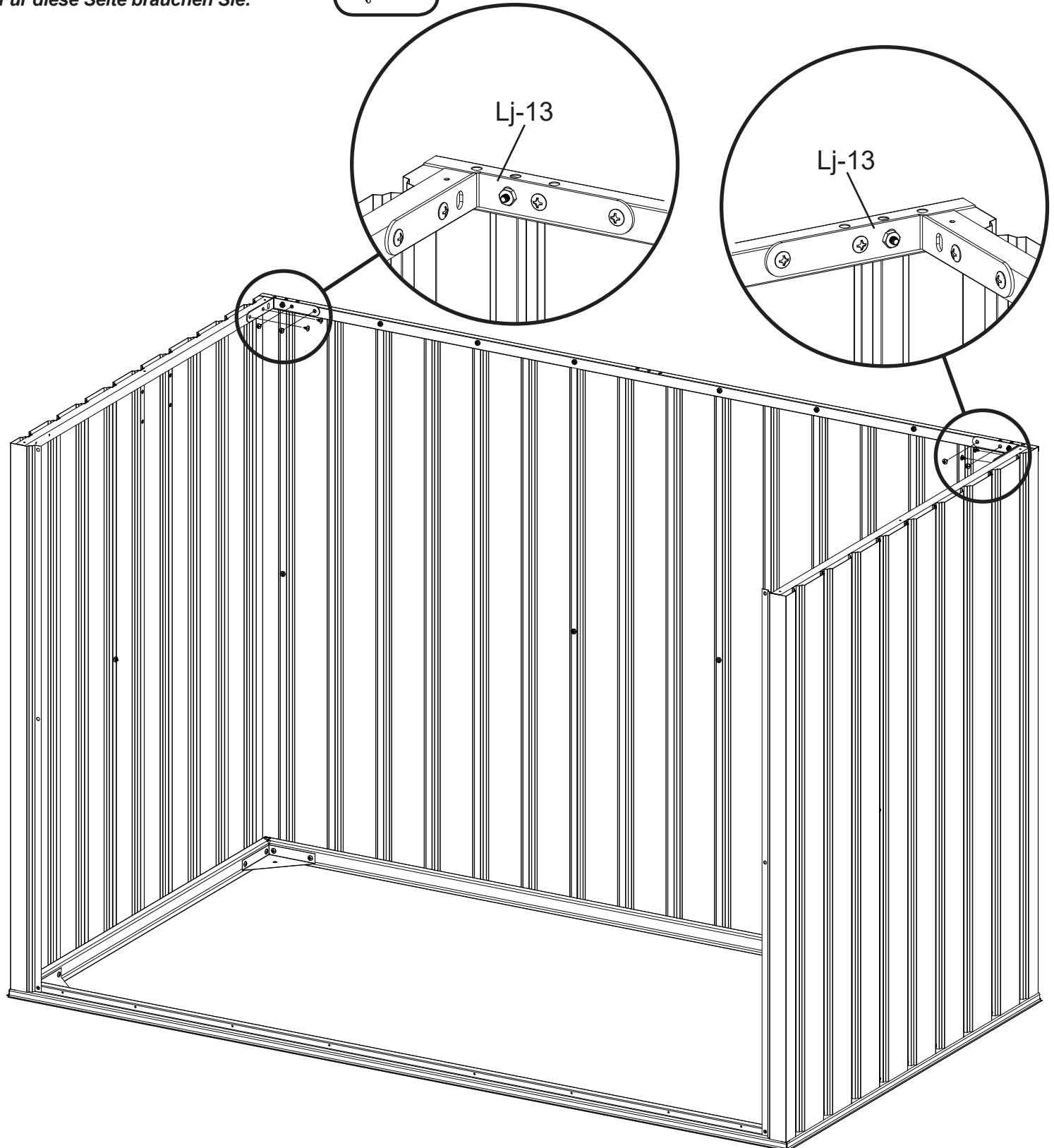
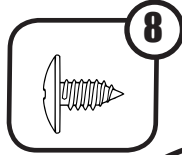

# Step 3 / Étape 3 / Paso 3 / Schritt 3

You will need for this page:

Nécessaire pour cette page:

Usted necesitará para esta página:

Für diese Seite brauchen Sie:

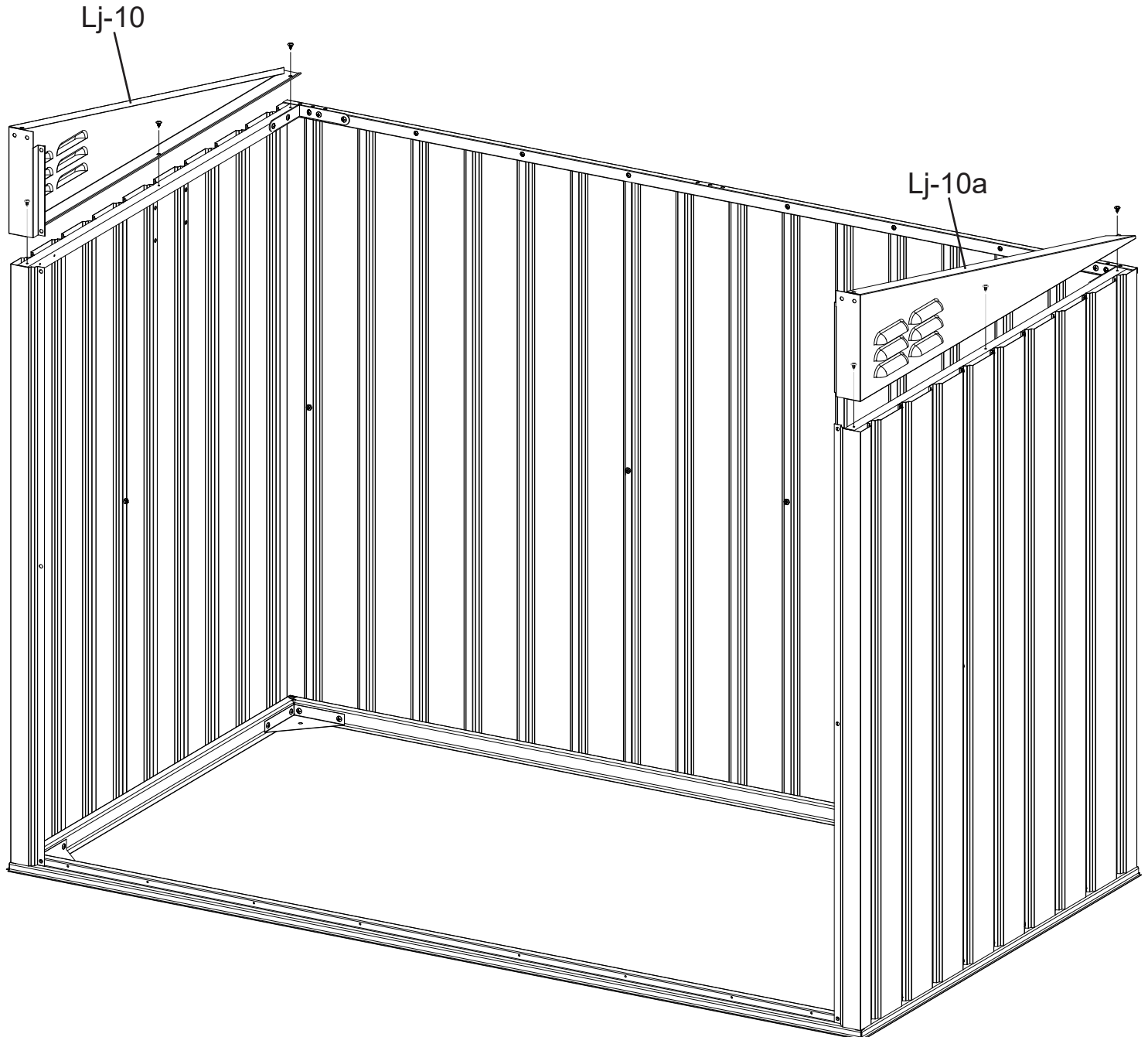
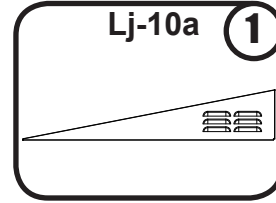
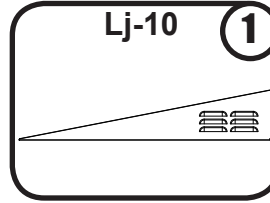
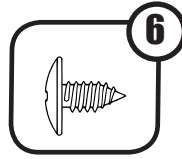



# Step 3 / Étape 3 / Paso 3 / Schritt 3

You will need for this page:

Nécessaire pour cette page:

Usted necesitará para esta página:

Für diese Seite brauchen Sie:

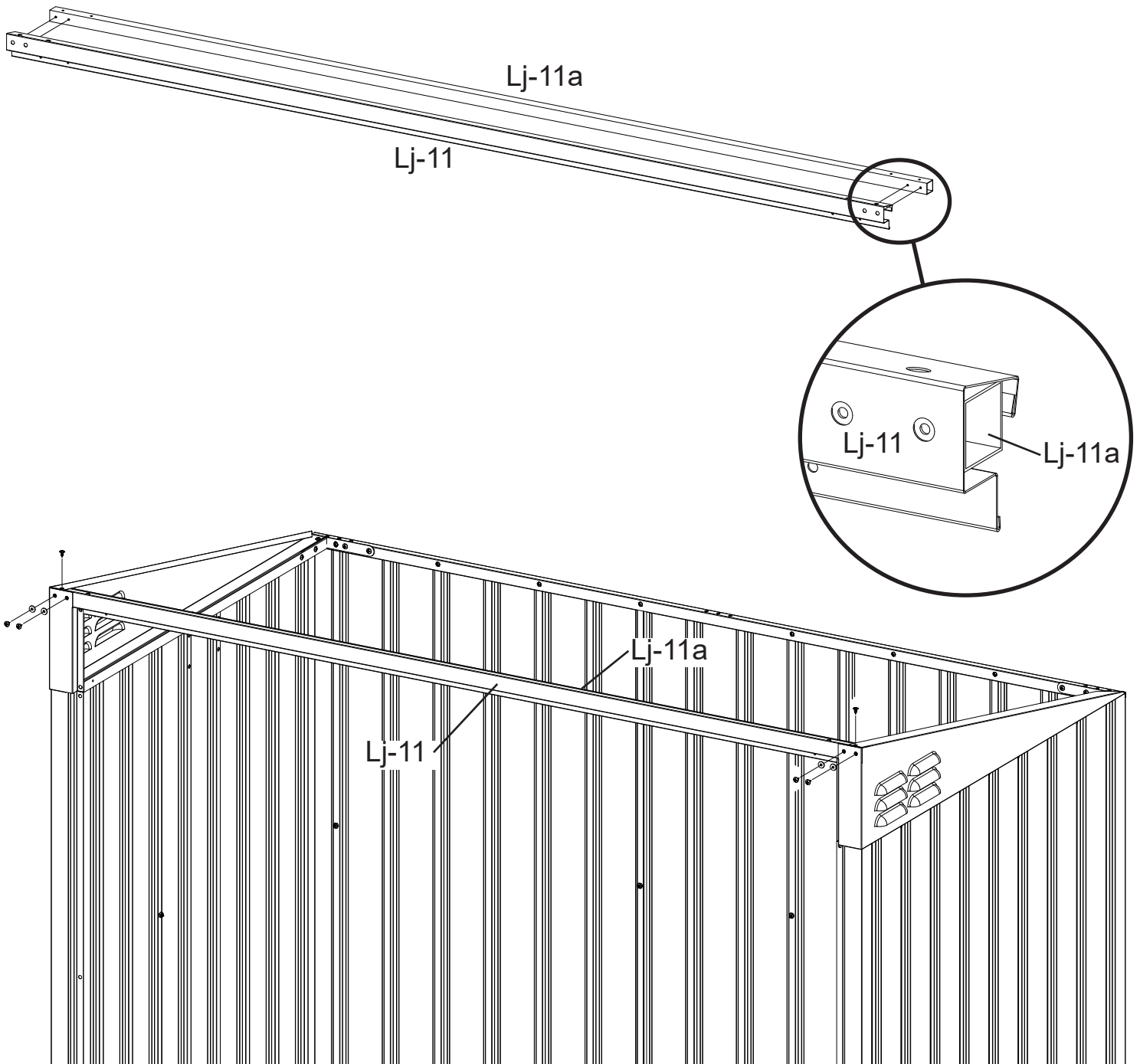
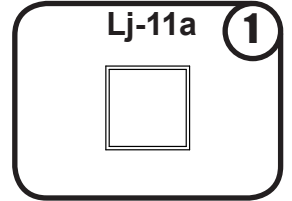
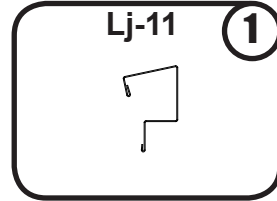
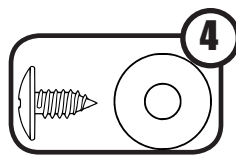
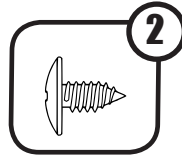

# Step 3 / Étape 3 / Paso 3 / Schritt 3

You will need for this page:

Nécessaire pour cette page:

Usted necesitará para esta página:

Für diese Seite brauchen Sie:

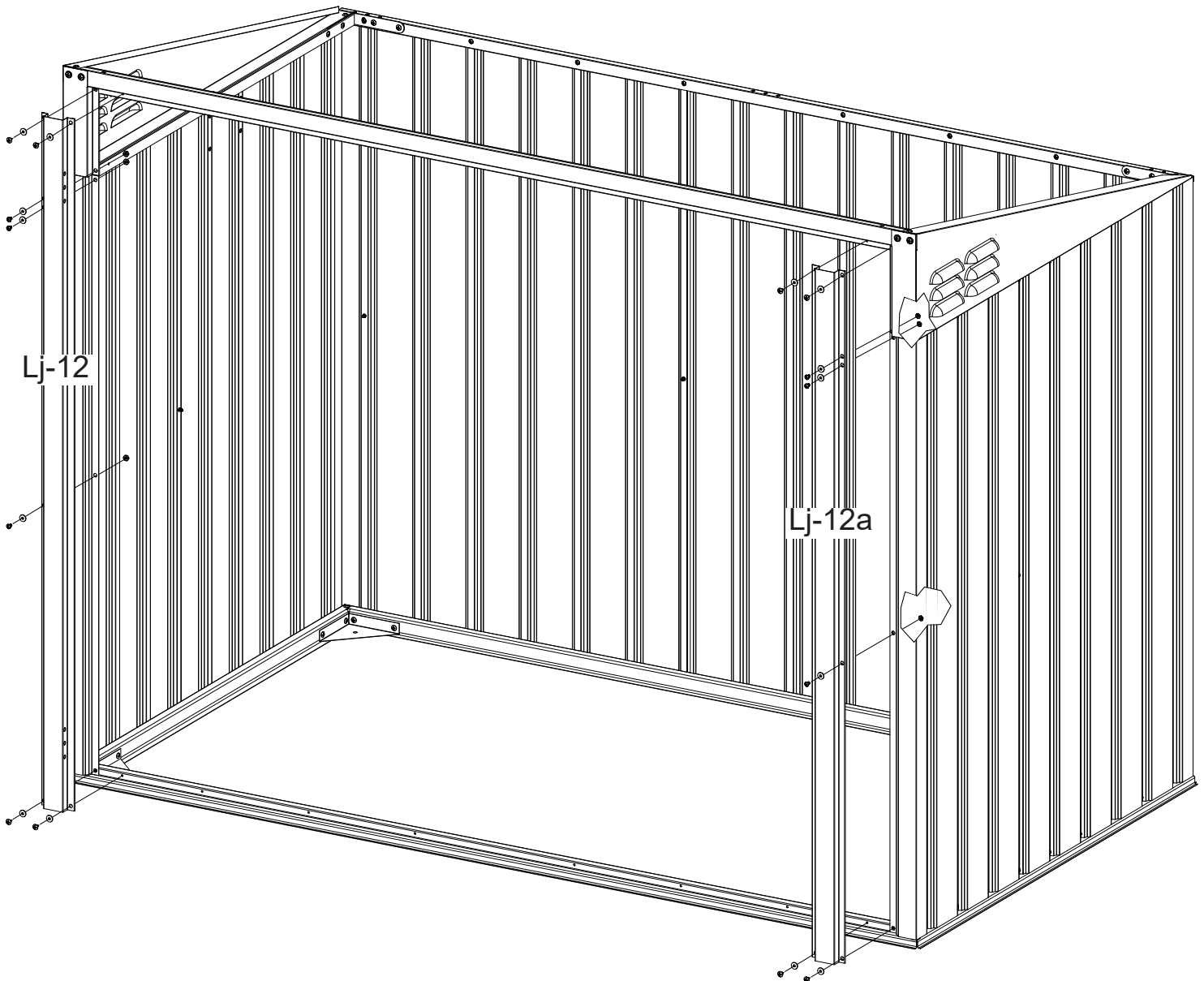
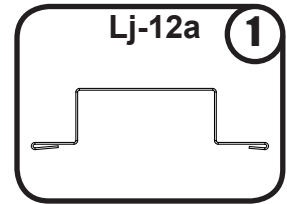
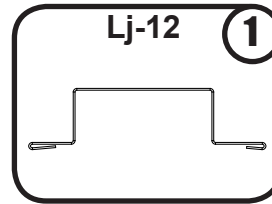
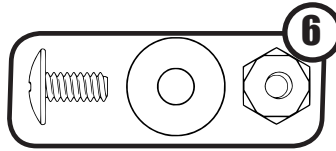
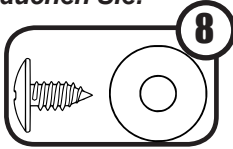

# Step 3 / Étape 3 / Paso 3 / Schritt 3

You will need for this page:

Nécessaire pour cette page:

Usted necesitará para esta página:

Für diese Seite brauchen Sie:

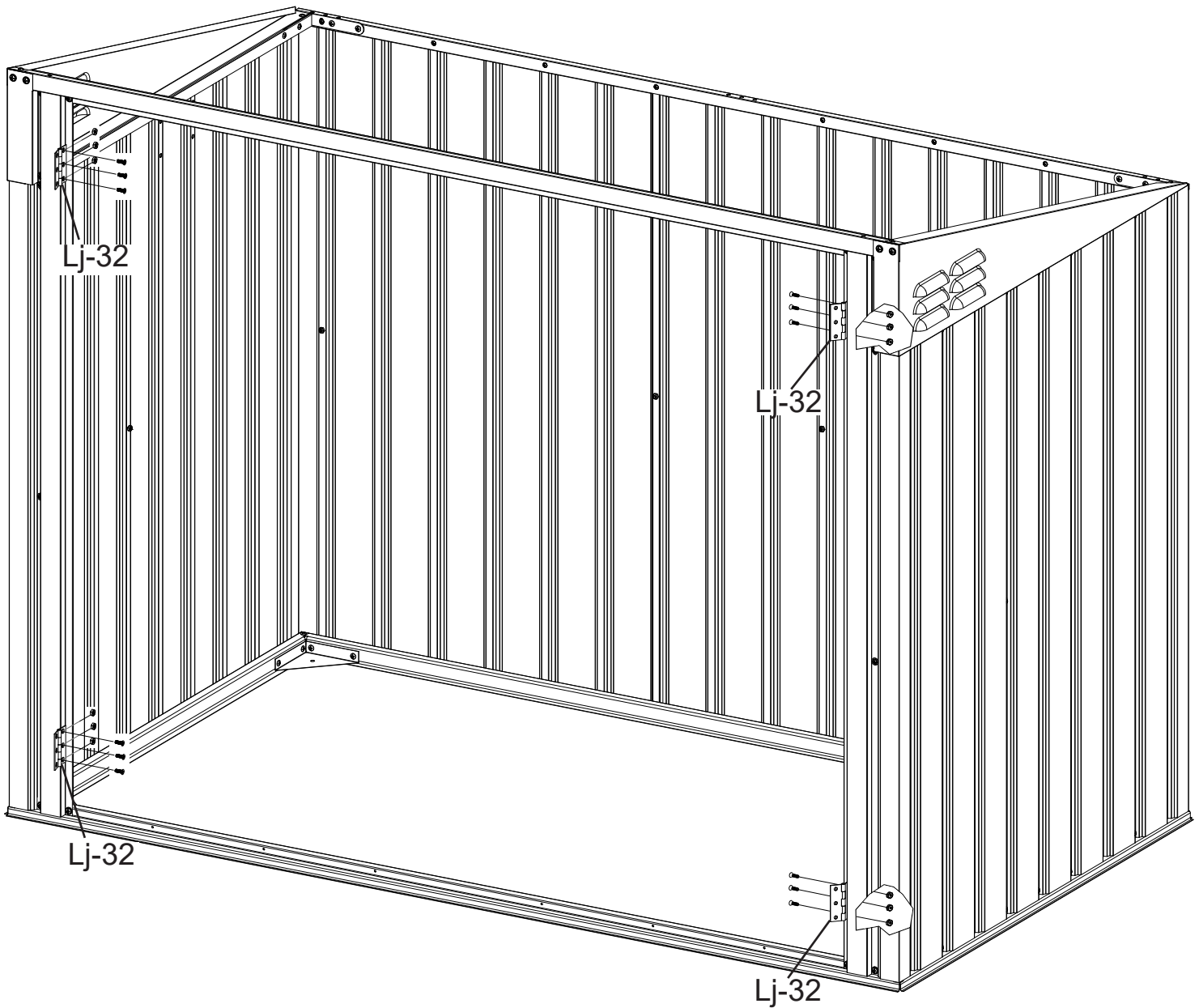
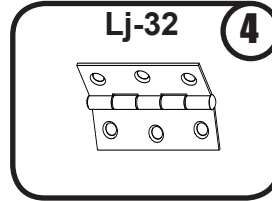
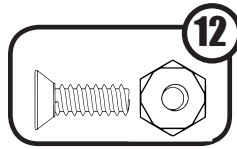

# Step 3 / Étape 3 / Paso 3 / Schritt 3

You will need for this page:

Nécessaire pour cette page:

Usted necesitará para esta página:

Für diese Seite brauchen Sie:

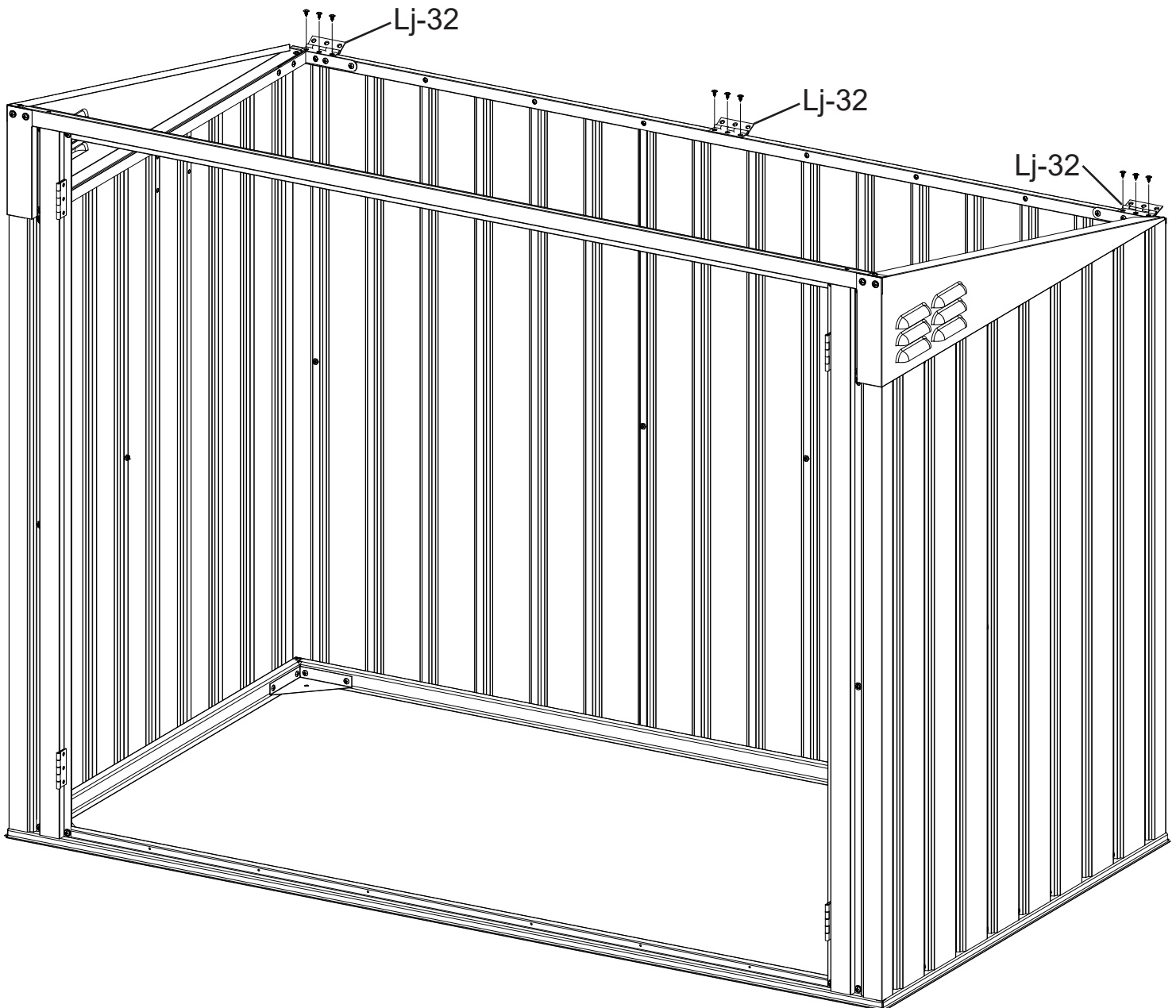
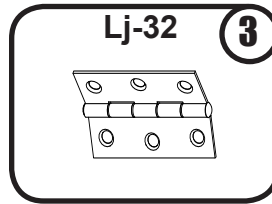
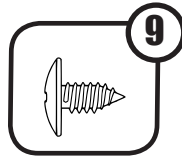

# Step 3 / Étape 3 / Paso 3 / Schritt 3

You will need for this page:

Nécessaire pour cette page:

Usted necesitará para esta página:

Für diese Seite brauchen Sie:

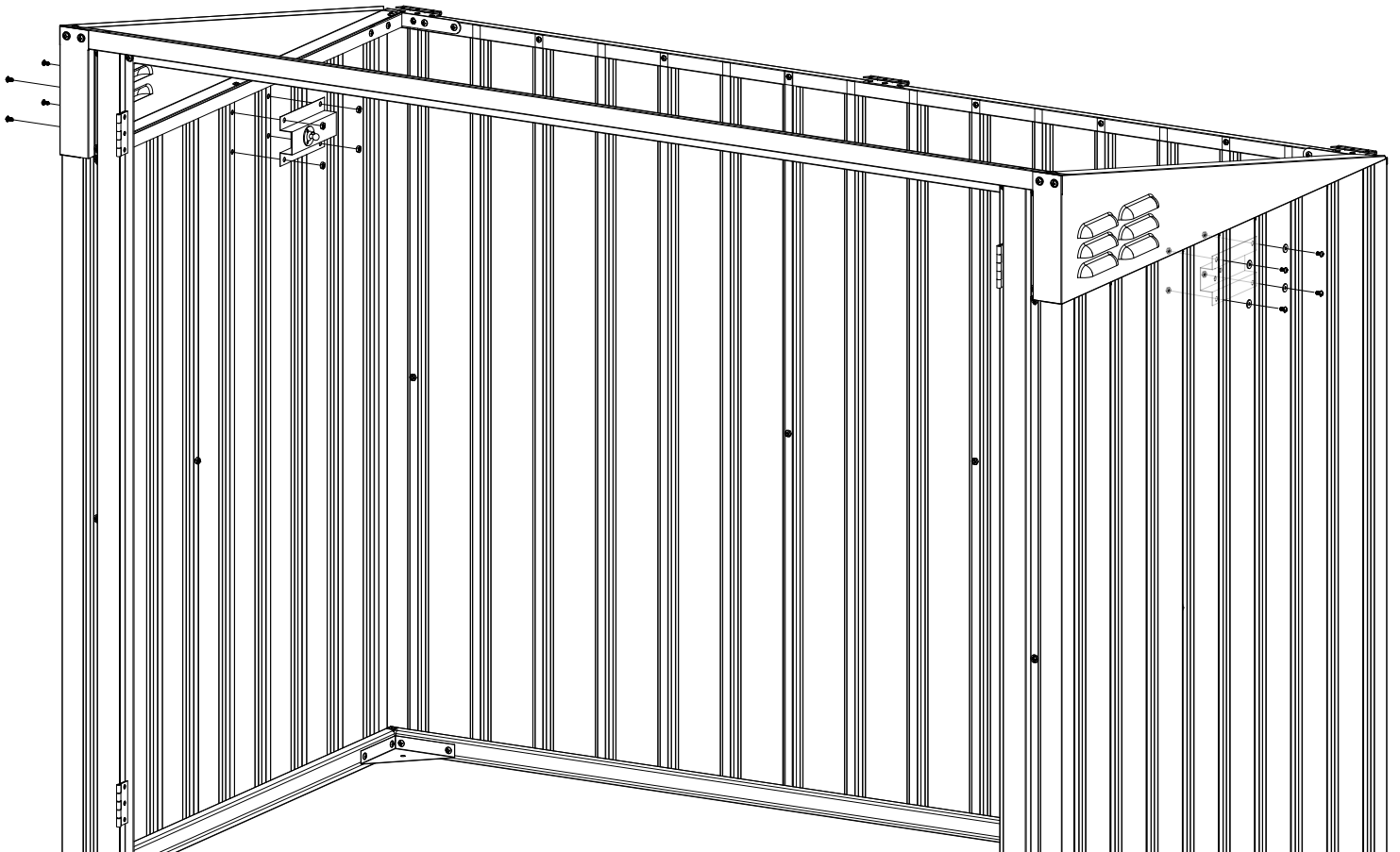
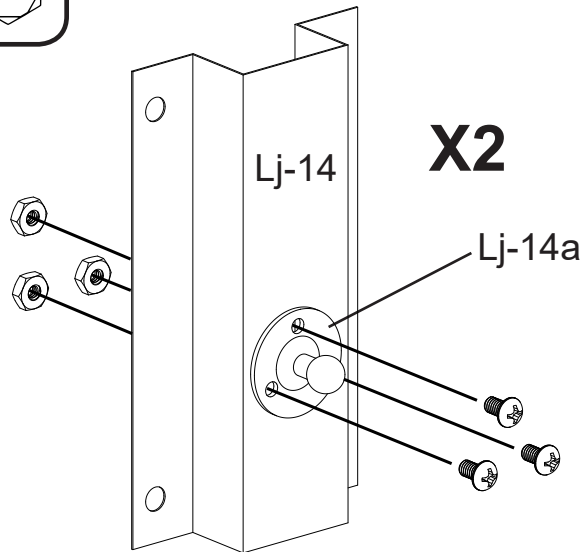
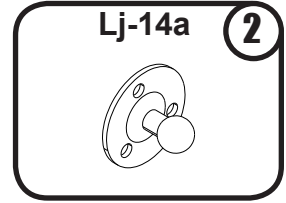
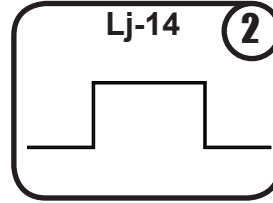
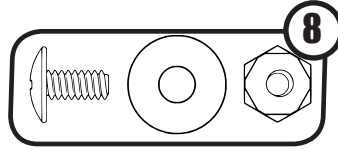
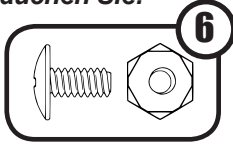

# Step 4 / Étape 4 / Paso 4 / Schritt 4

You will need for this page:

Nécessaire pour cette page:

Usted necesitará para esta página:

Für diese Seite brauchen Sie:

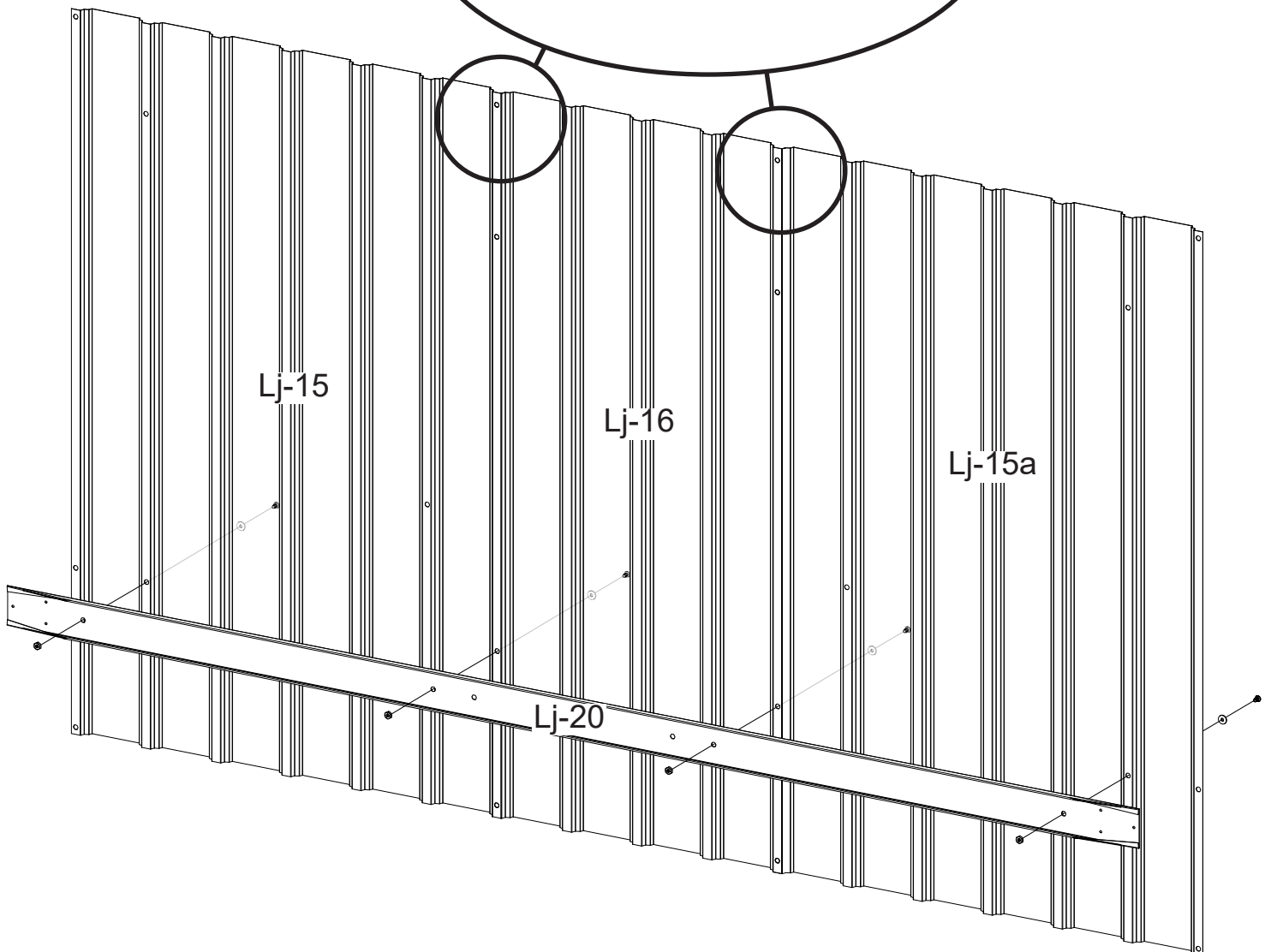
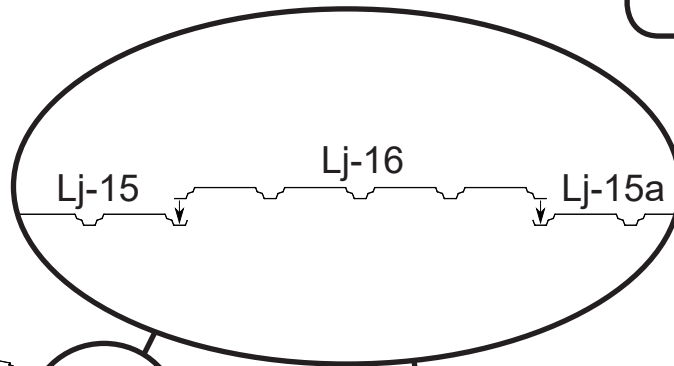
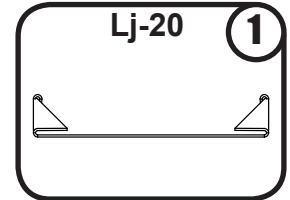
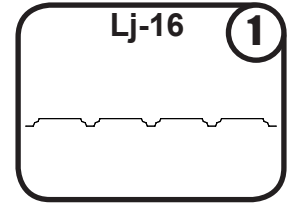
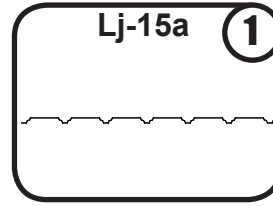
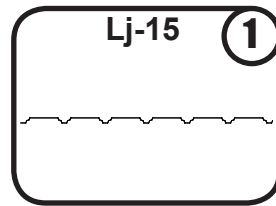
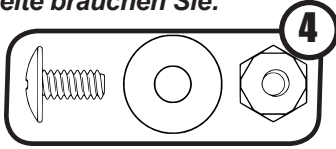

# Step 4 / Étape 4 / Paso 4 / Schritt 4

You will need for this page:

Nécessaire pour cette page:

Usted necesitará para esta página:

Für diese Seite brauchen Sie:

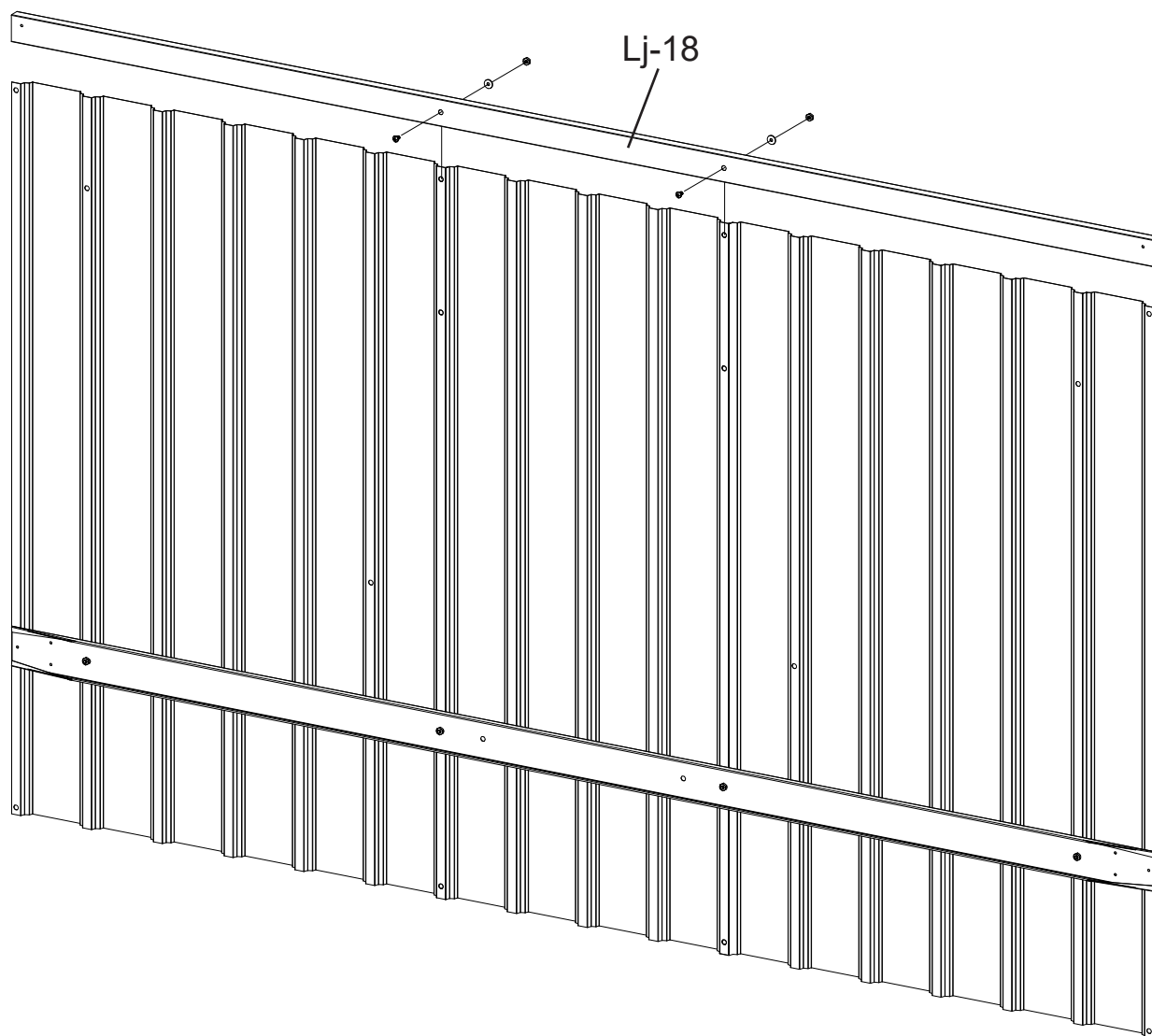
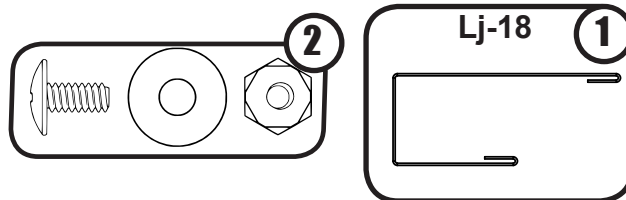

# Step 4 / Étape 4 / Paso 4 / Schritt 4

You will need for this page:

Nécessaire pour cette page:

Usted necesitará para esta página:

Für diese Seite brauchen Sie:

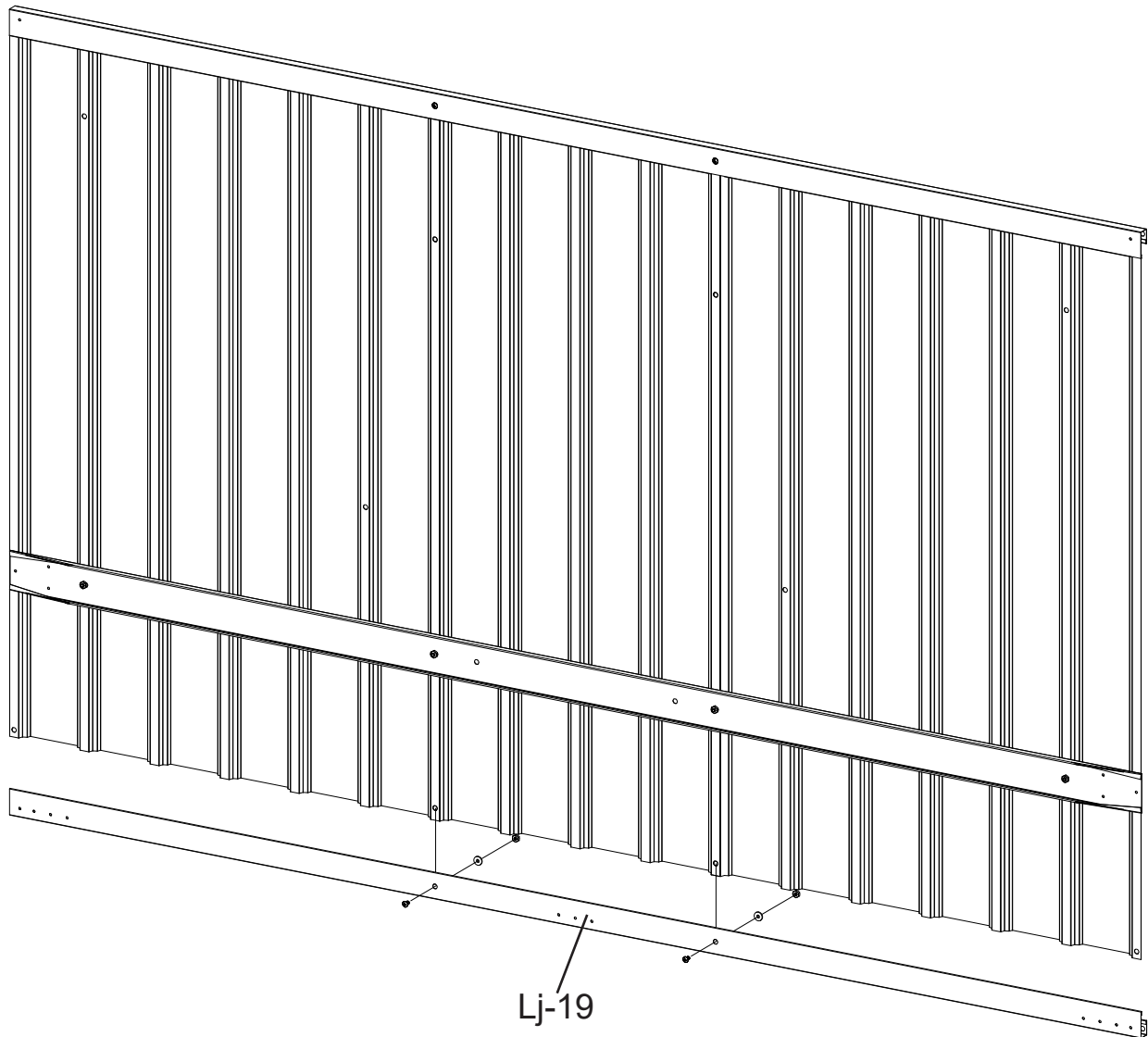
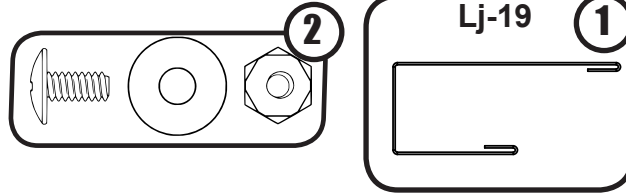



# Step 4 / Étape 4 / Paso 4 / Schritt 4

You will need for this page:

Nécessaire pour cette page:

Usted necesitará para esta página:

Für diese Seite brauchen Sie:

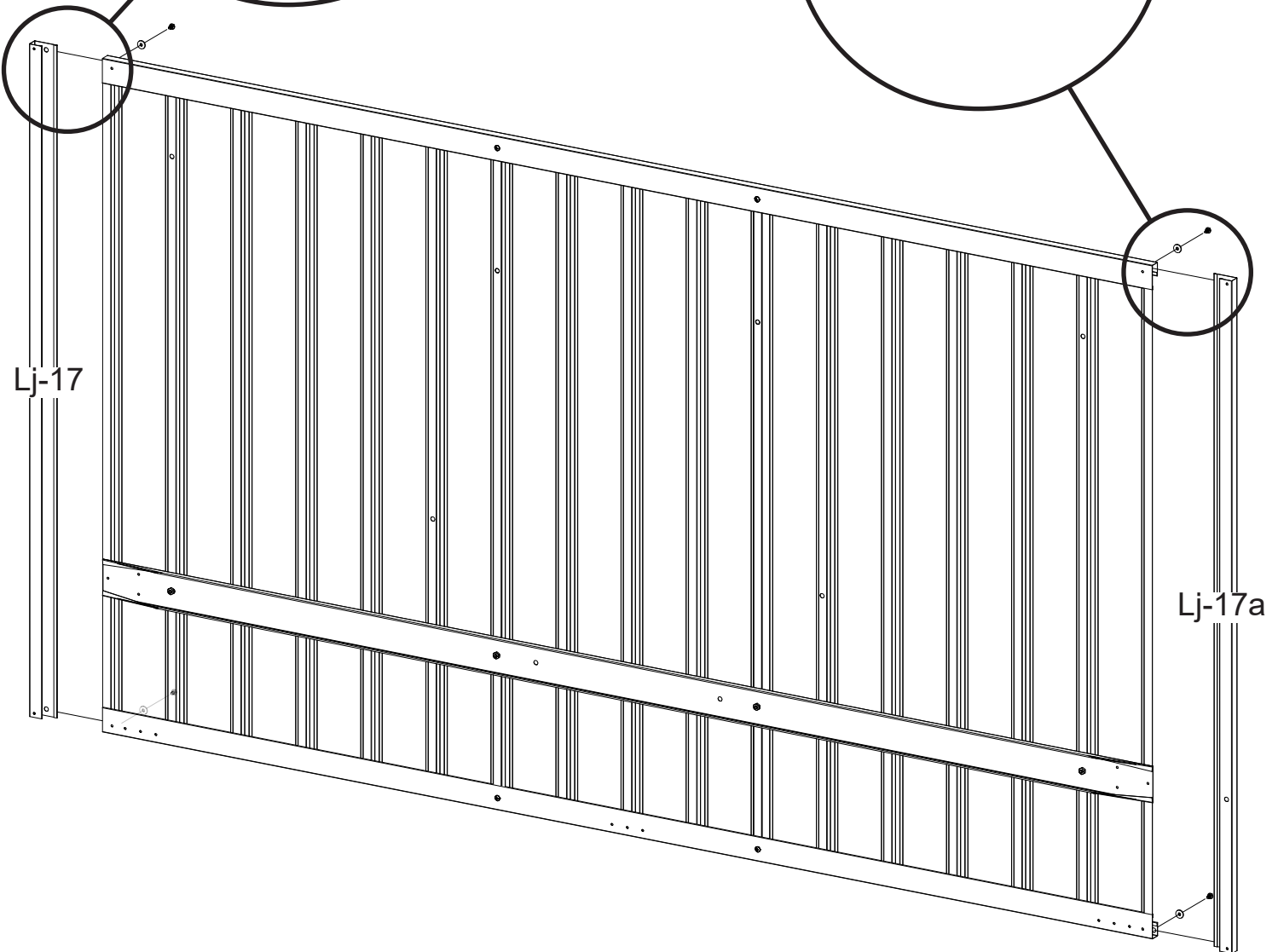
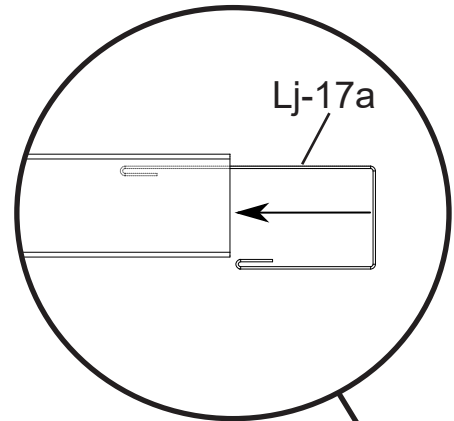
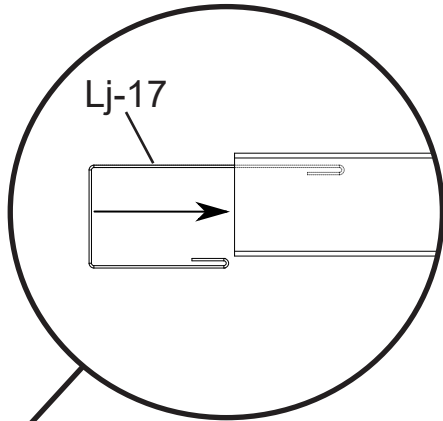
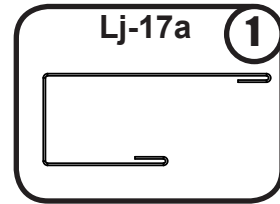
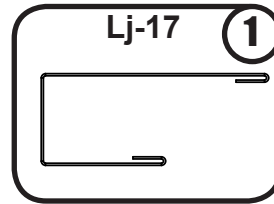
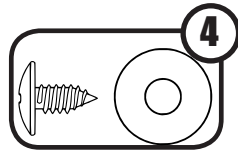

# Step 4 / Étape 4 / Paso 4 / Schritt 4

You will need for this page:

Nécessaire pour cette page:

Usted necesitará para esta página:

Für diese Seite brauchen Sie:

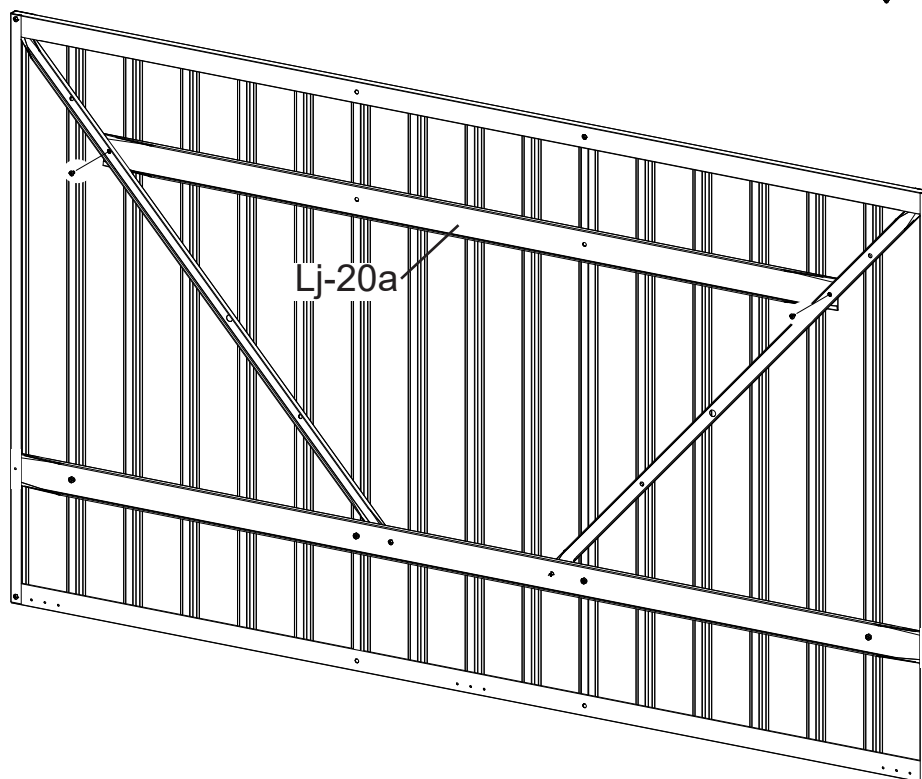
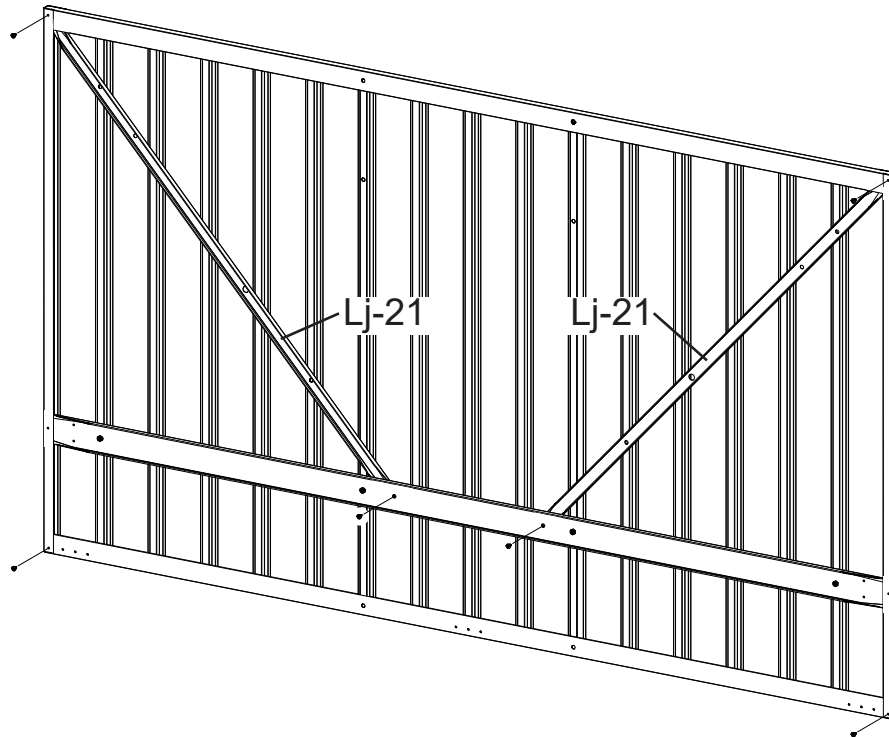
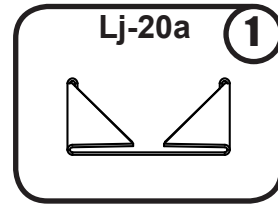
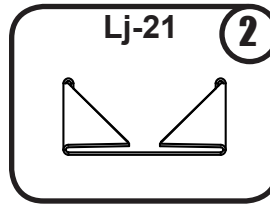
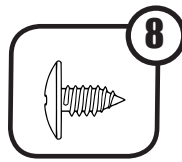

# Step 4 / Étape 4 / Paso 4 / Schritt 4

You will need for this page:

Nécessaire pour cette page:

Usted necesitará para esta página:

Für diese Seite brauchen Sie:

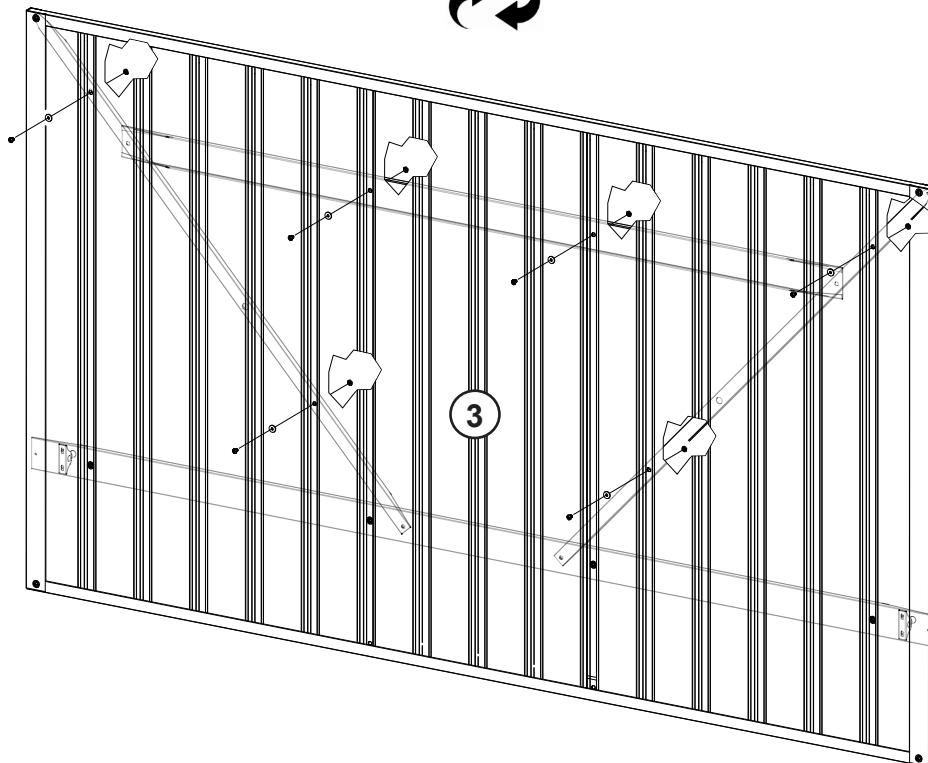
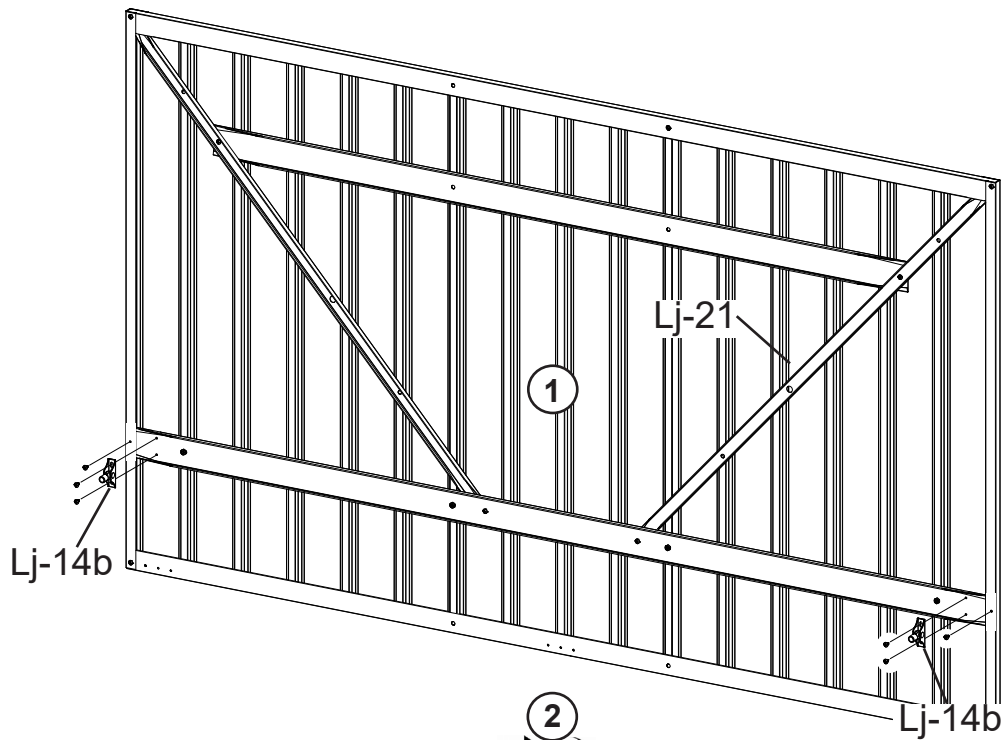
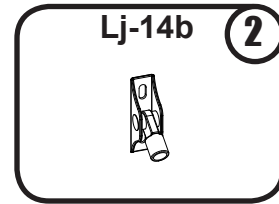
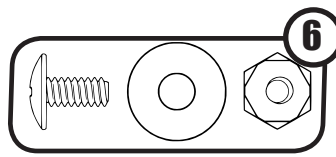
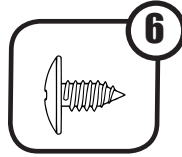

# Step 4 / Étape 4 / Paso 4 / Schritt 4

*You will need for this page:*

*Nécessaire pour cette page:*

*Usted necesitará para esta página:*

*Für diese Seite brauchen Sie:*

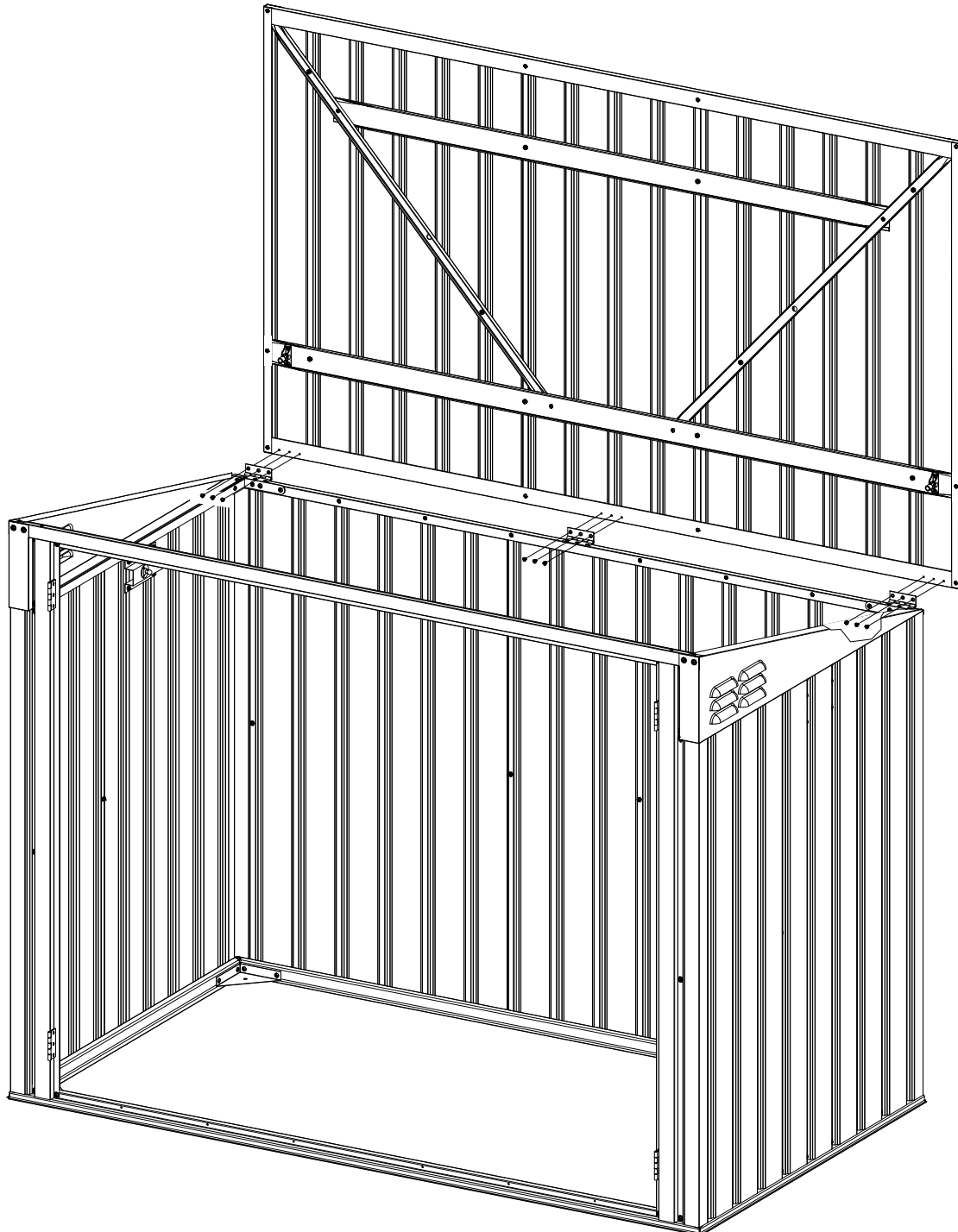
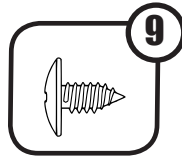

# Step 4 / Étape 4 / Paso 4 / Schritt 4

You will need for this page:

Nécessaire pour cette page:

Usted necesitará para esta página:

Für diese Seite brauchen Sie:

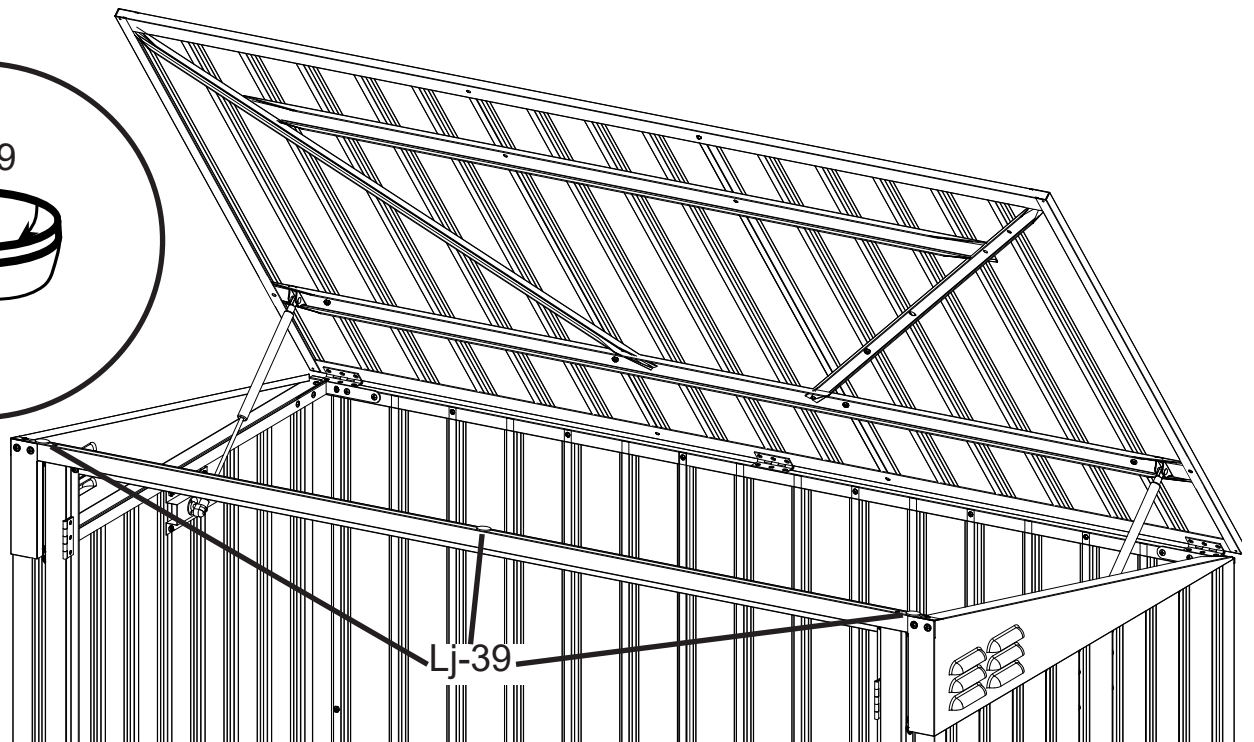
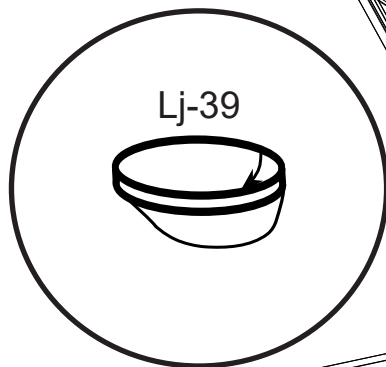
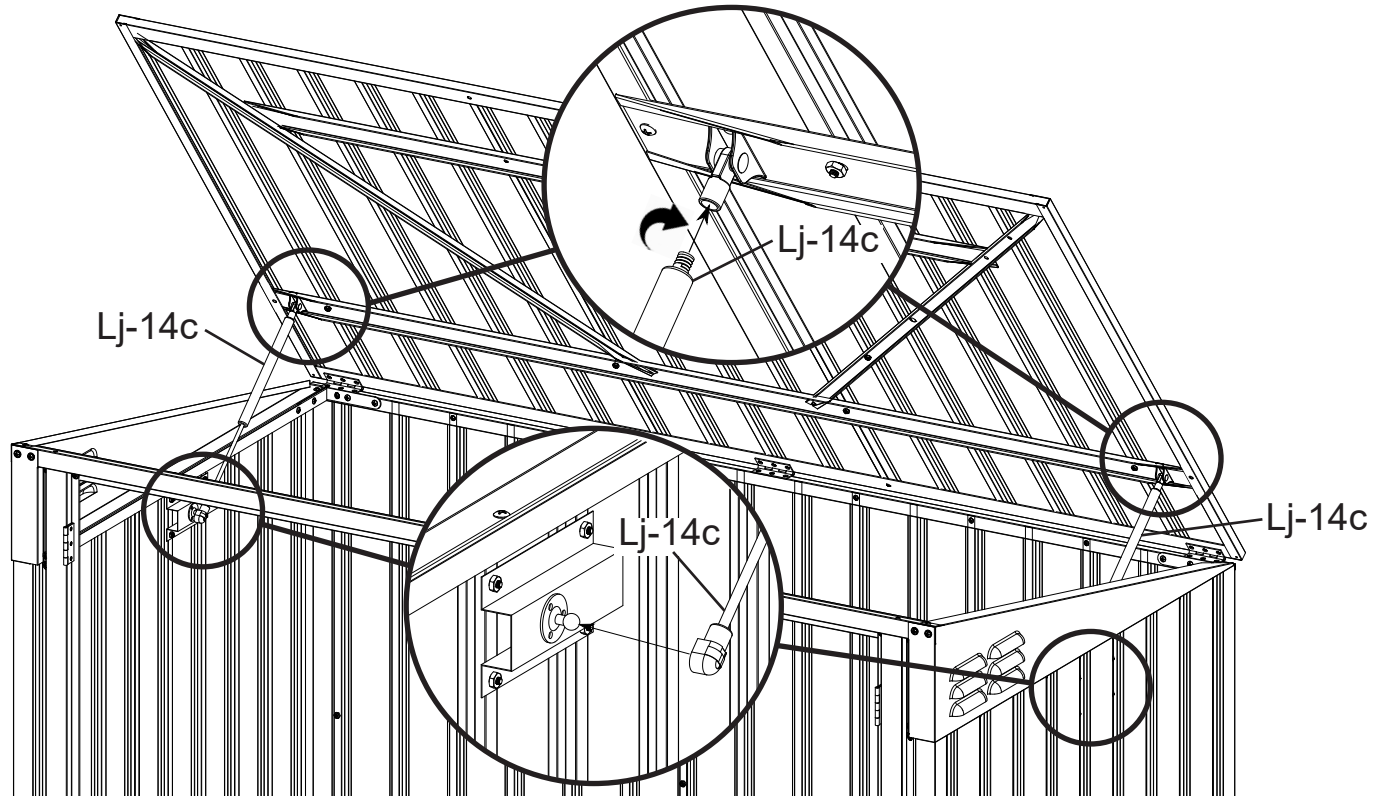
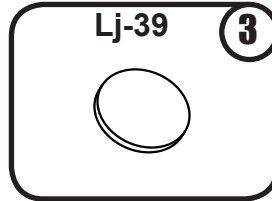
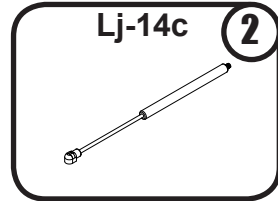

# Step 5 / Étape 5 / Paso 5 / Schritt 5

You will need for this page:

Nécessaire pour cette page:

Usted necesitará para esta página:

Für diese Seite brauchen Sie:

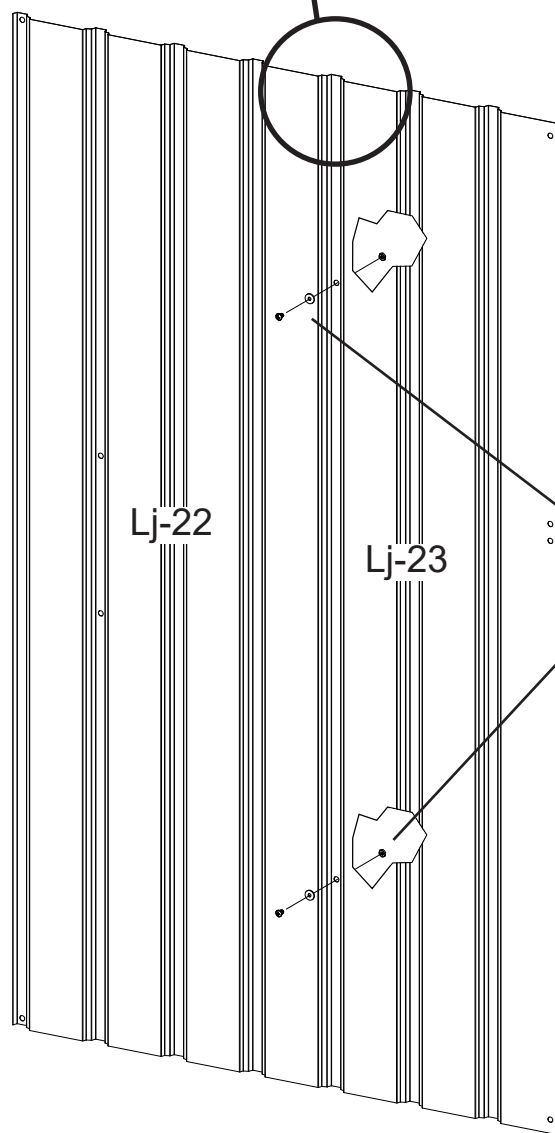
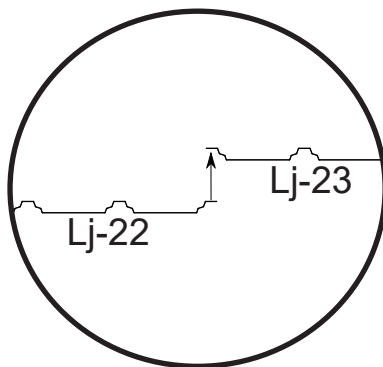
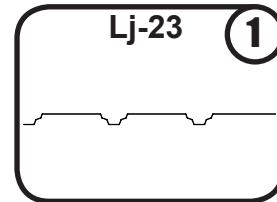
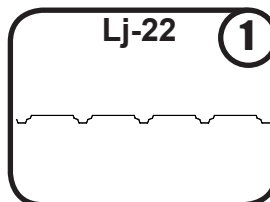
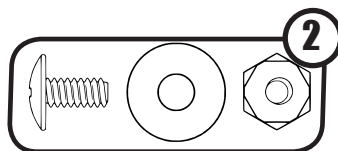

**NOTE: DO NOT TIGHTEN AT THIS TIME**  
**REMARQUE : NE PAS SERRER À CE MOMENT-CI**  
**NOTA: NO TENSIONE EN ESTE MOMENTO**  
**HINWEIS: NOCH NICHT FESTZIEHEN**

# Step 5 / Étape 5 / Paso 5 / Schritt 5

You will need for this page:

Nécessaire pour cette page:

Usted necesitará para esta página:

Für diese Seite brauchen Sie:

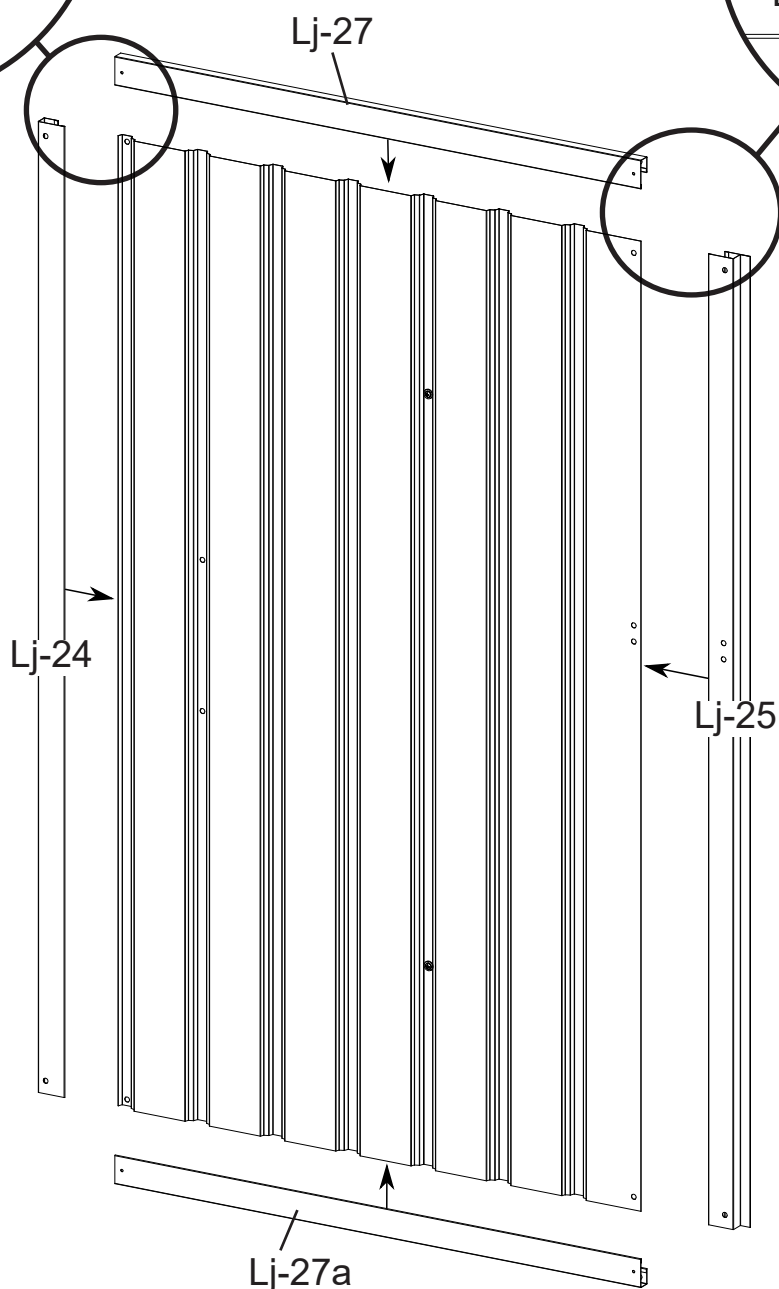
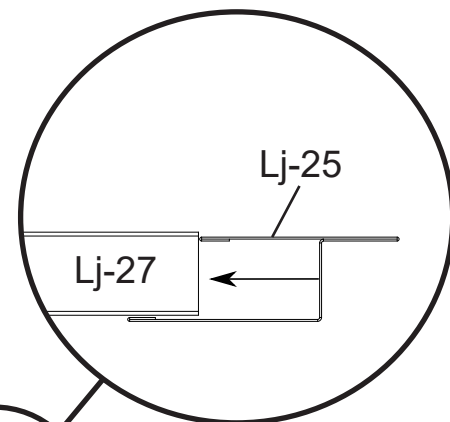
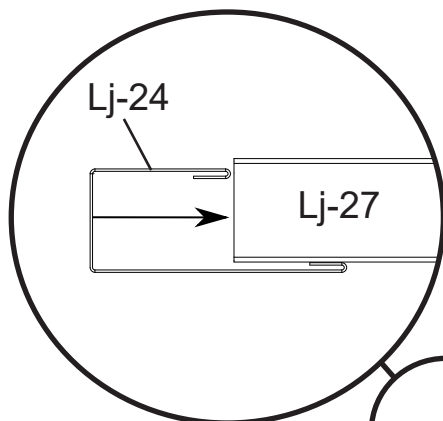
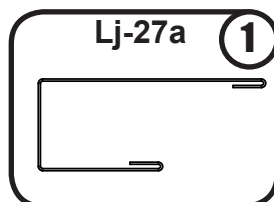
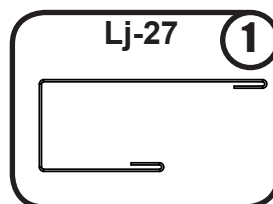
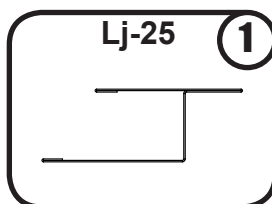
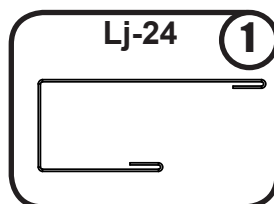

# Step 5 / Étape 5 / Paso 5 / Schritt 5

You will need for this page:

Nécessaire pour cette page:

Usted necesitará para esta página:

Für diese Seite brauchen Sie:

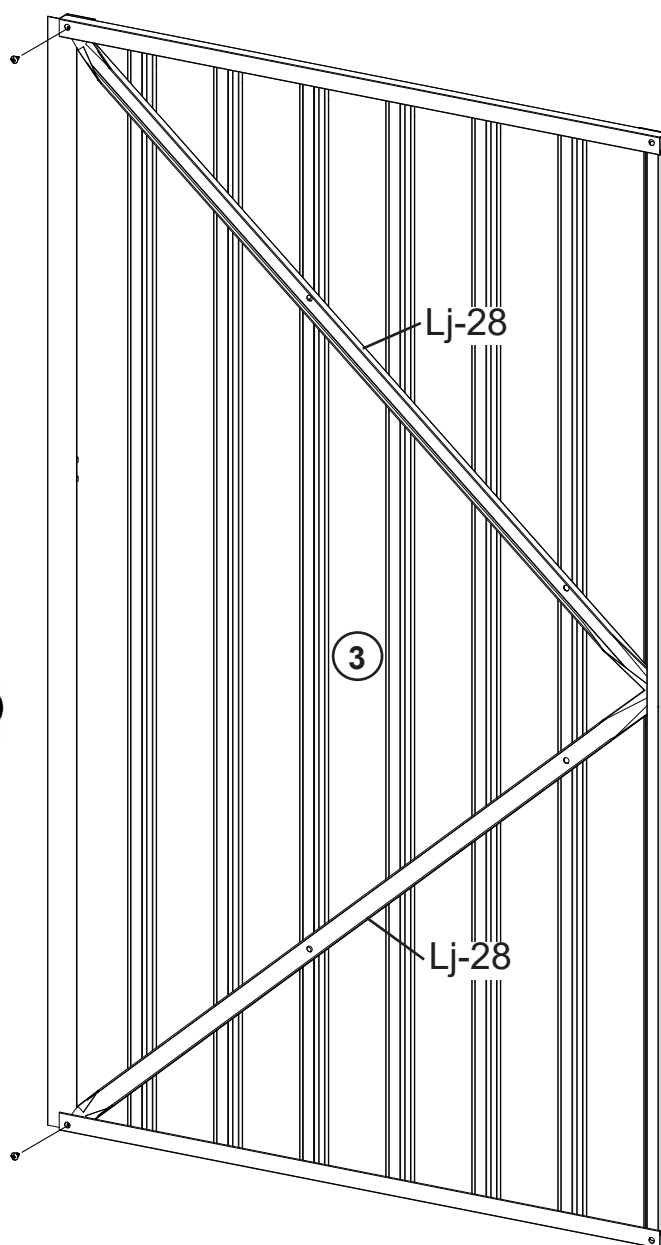
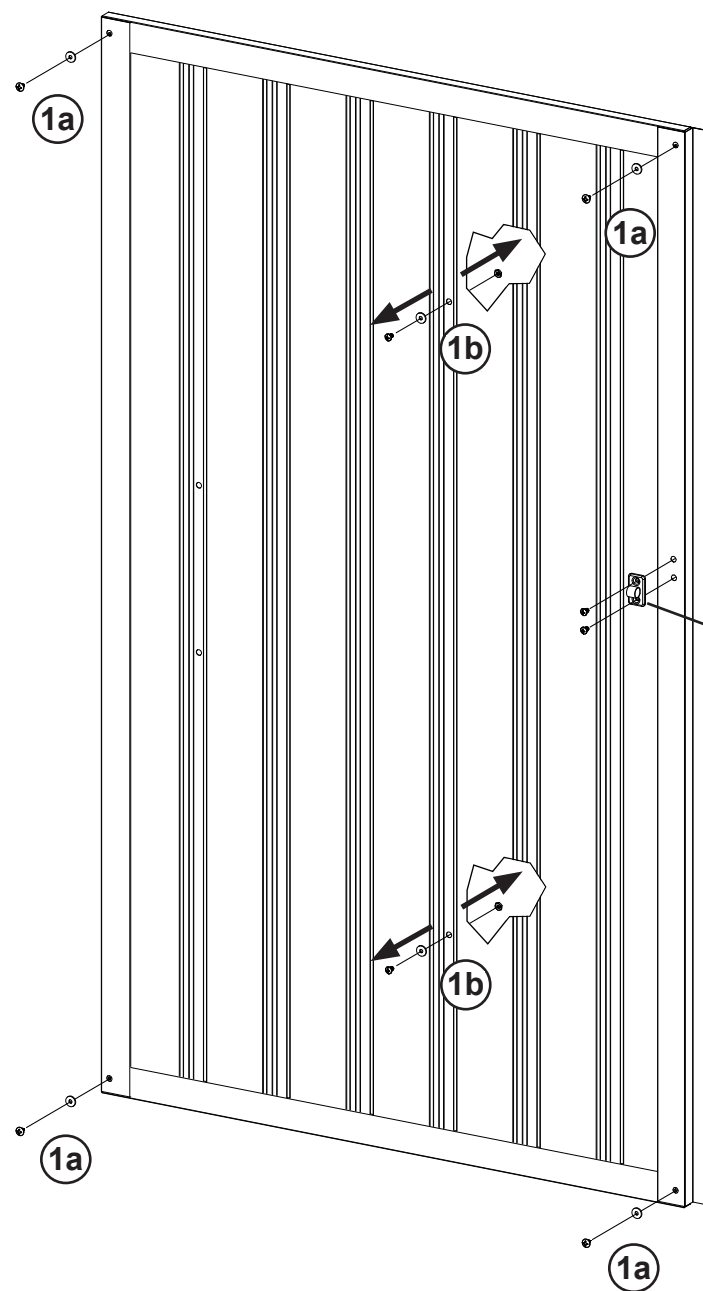
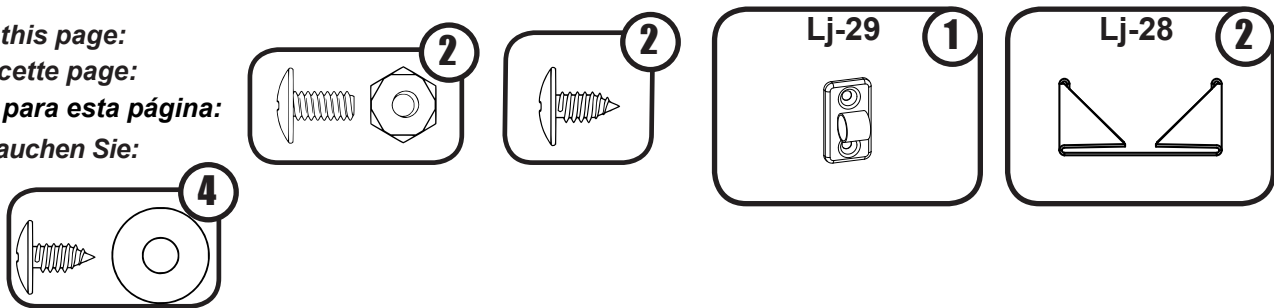



# Step 5 / Étape 5 / Paso 5 / Schritt 5

You will need for this page:

Nécessaire pour cette page:

Usted necesitará para esta página:

Für diese Seite brauchen Sie:

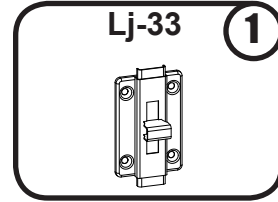
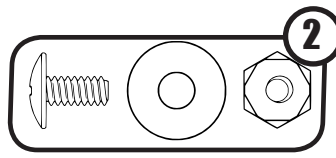
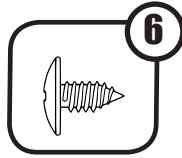

Lj-33

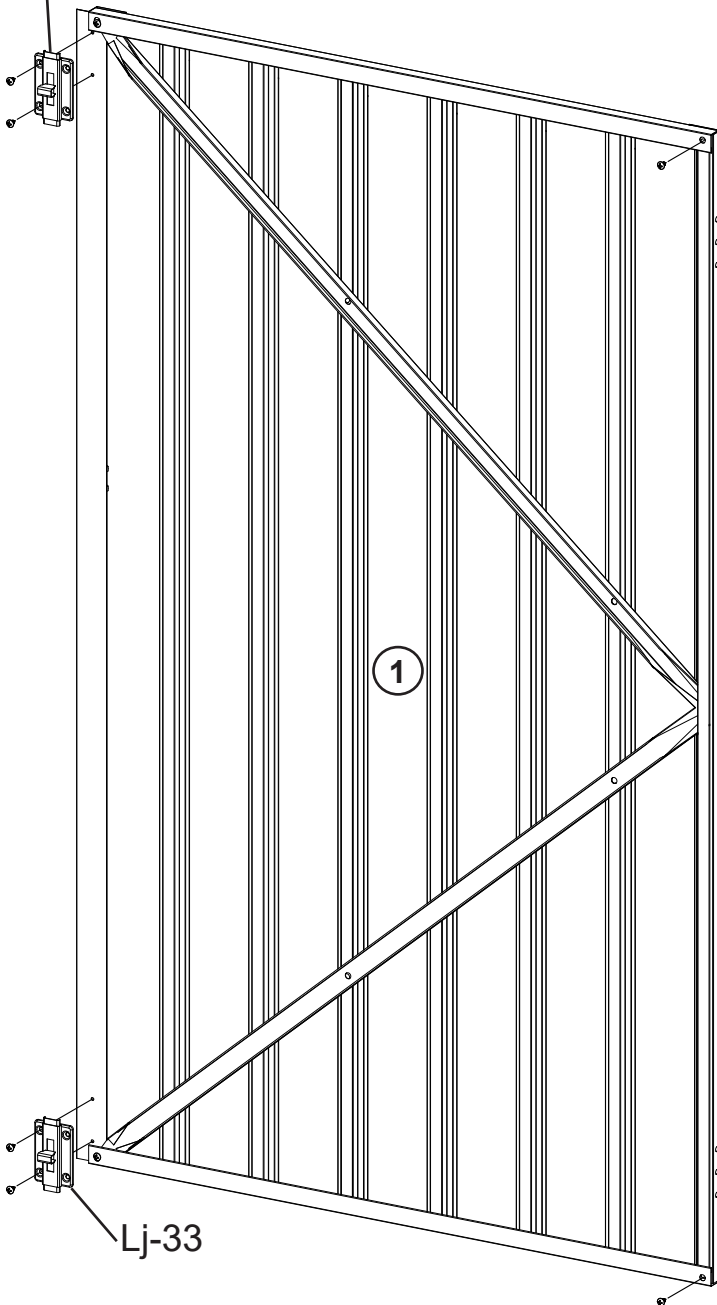

Lj-33

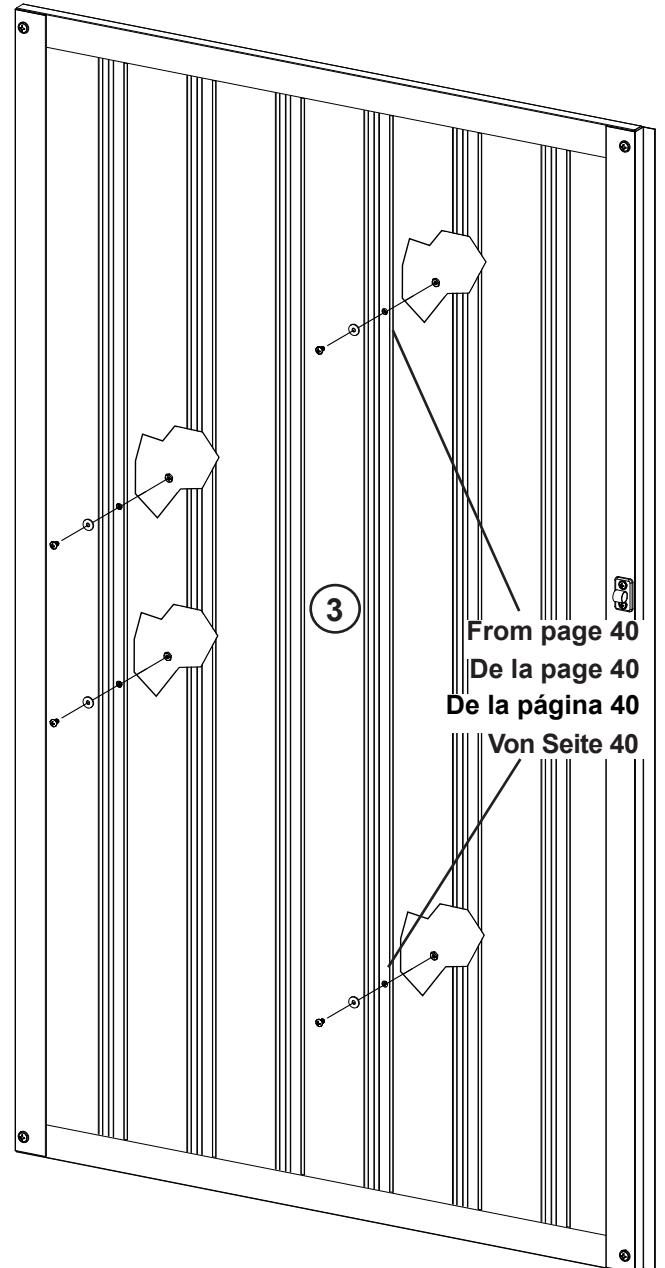

From page 40  
De la page 40  
De la página 40  
Von Seite 40

# Step 5 / Étape 5 / Paso 5 / Schritt 5

You will need for this page:

Nécessaire pour cette page:

Usted necesitará para esta página:

Für diese Seite brauchen Sie:

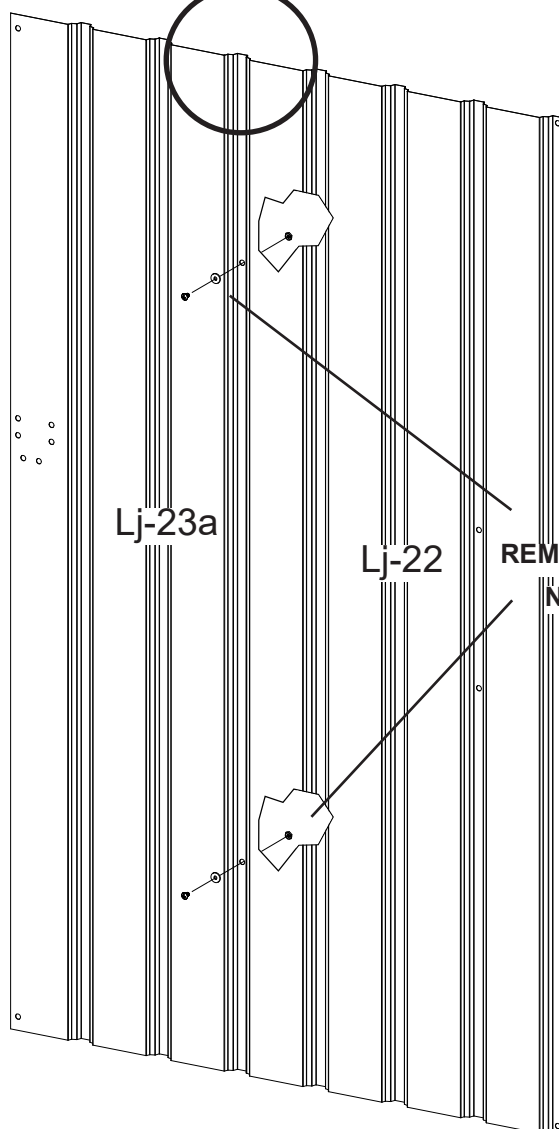
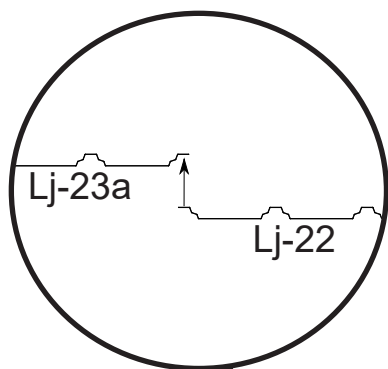
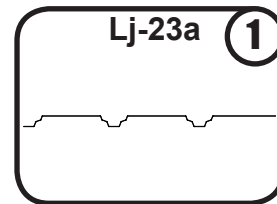
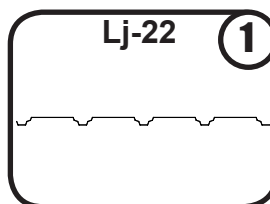
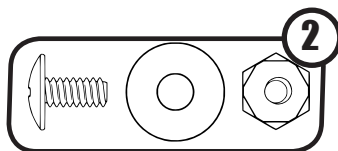

**NOTE: DO NOT TIGHTEN AT THIS TIME**  
**REMARQUE : NE PAS SERRER À CE MOMENT-CI**  
**NOTA: NO TENSIONE EN ESTE MOMENTO**  
**HINWEIS: NOCH NICHT FESTZIEHEN**

# Step 5 / Étape 5 / Paso 5 / Schritt 5

You will need for this page:

Nécessaire pour cette page:

Usted necesitará para esta página:

Für diese Seite brauchen Sie:

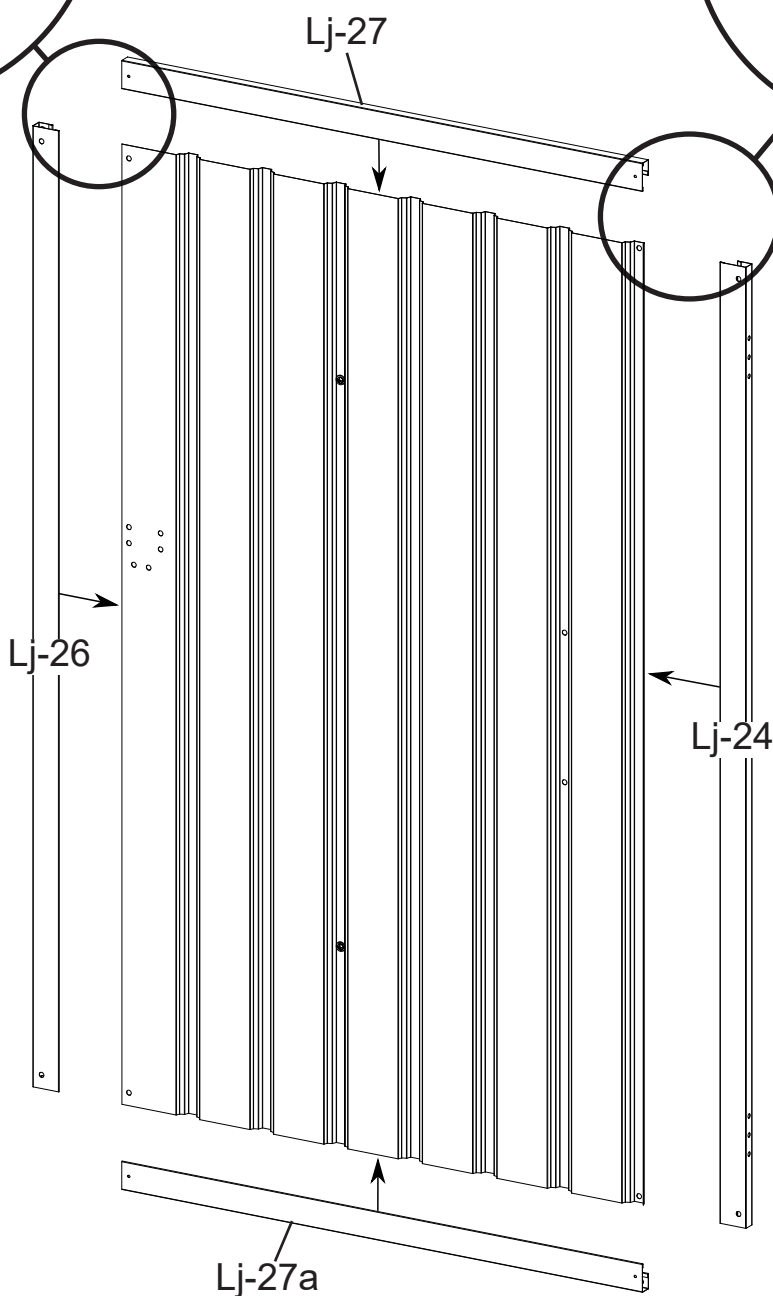
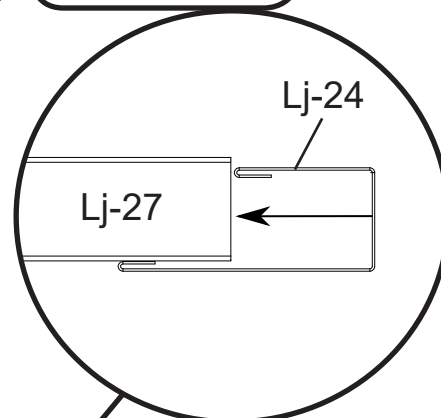
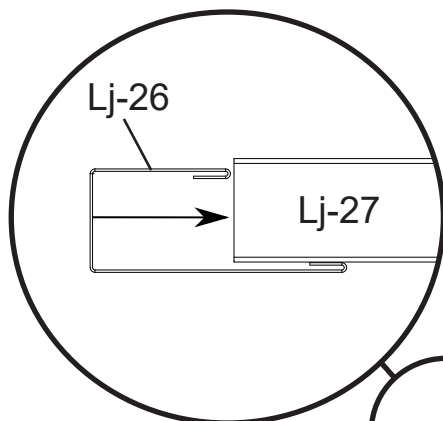
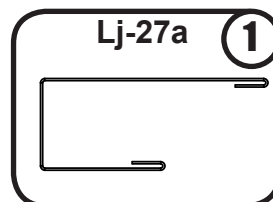
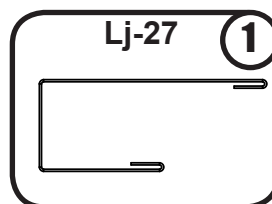
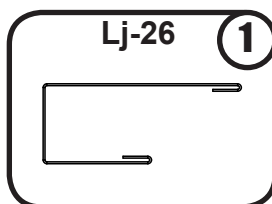
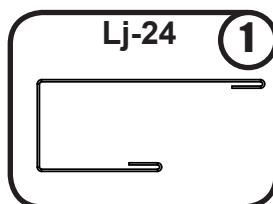

# Step 5 / Étape 5 / Paso 5 / Schritt 5

You will need for this page:

Nécessaire pour cette page:

Usted necesitará para esta página:

Für diese Seite brauchen Sie:

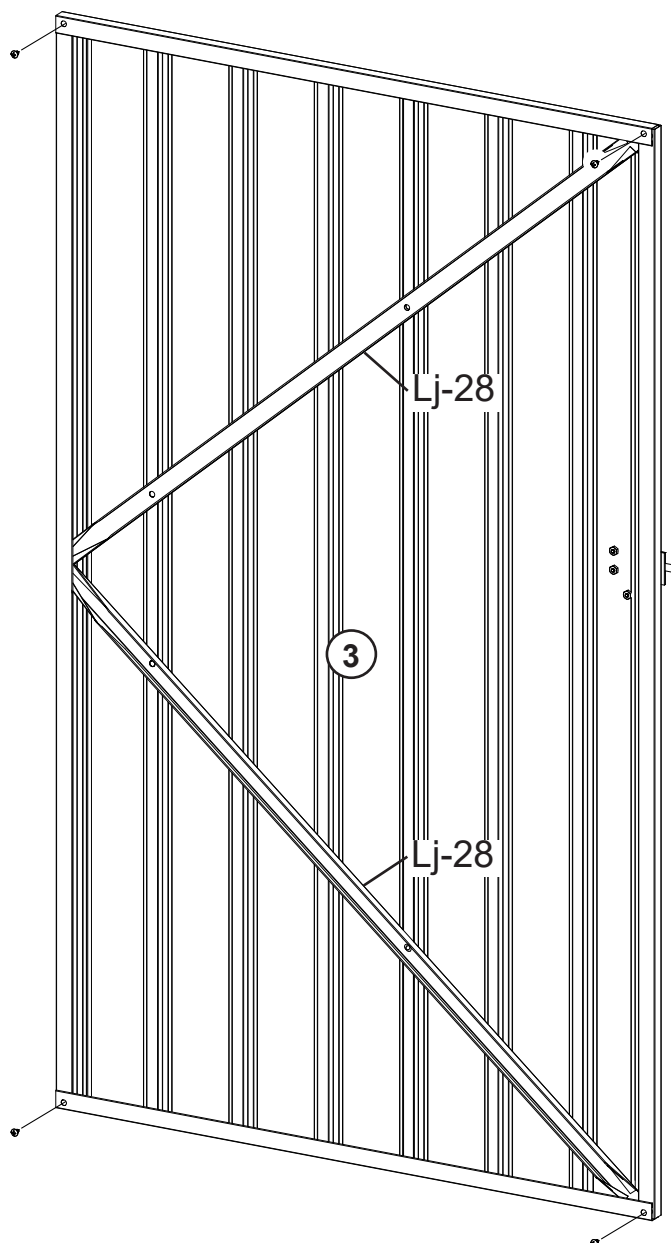
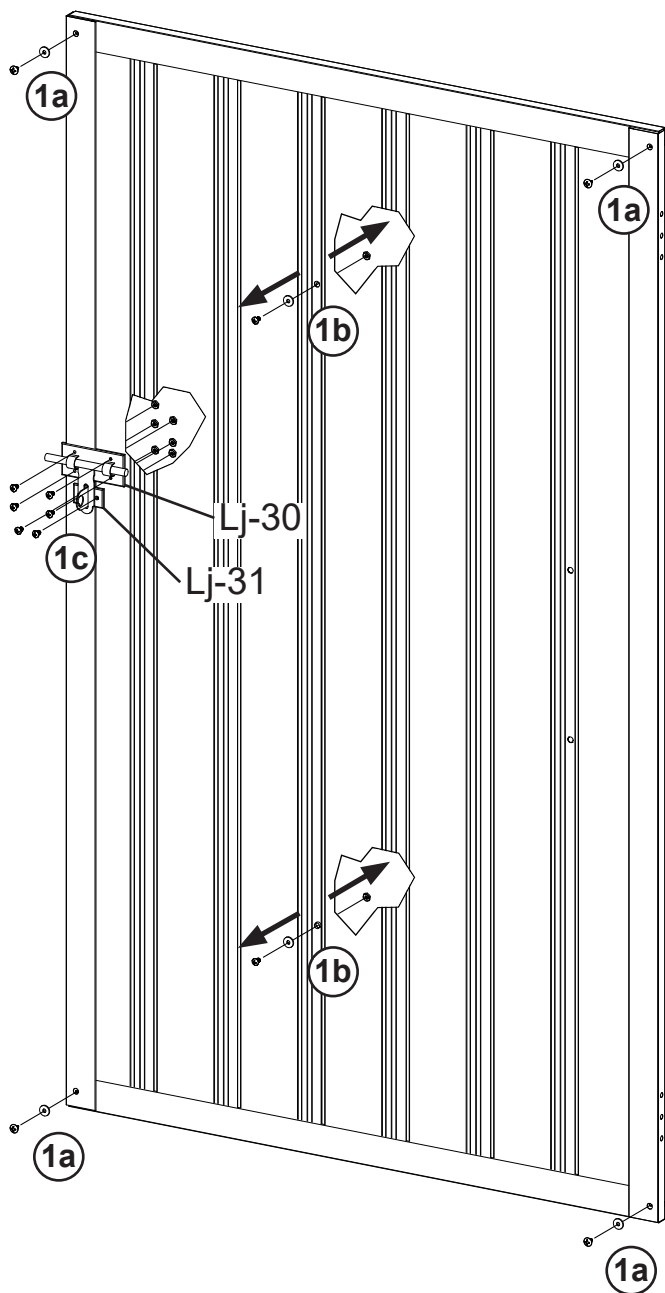
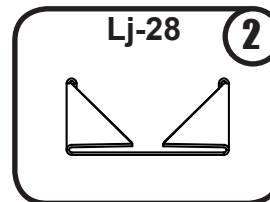
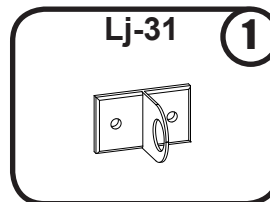
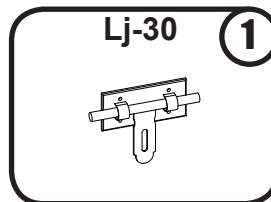
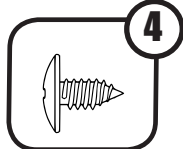
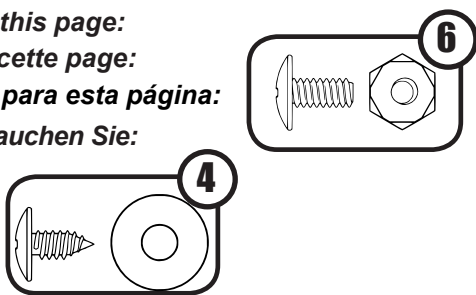

# Step 5 / Étape 5 / Paso 5 / Schritt 5

You will need for this page:

Nécessaire pour cette page:

Usted necesitará para esta página:

Für diese Seite brauchen Sie:

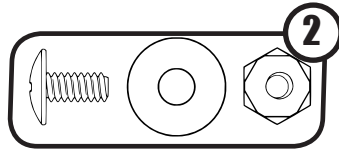

From page 44  
De la page 44  
De la página 44  
Von Seite 44

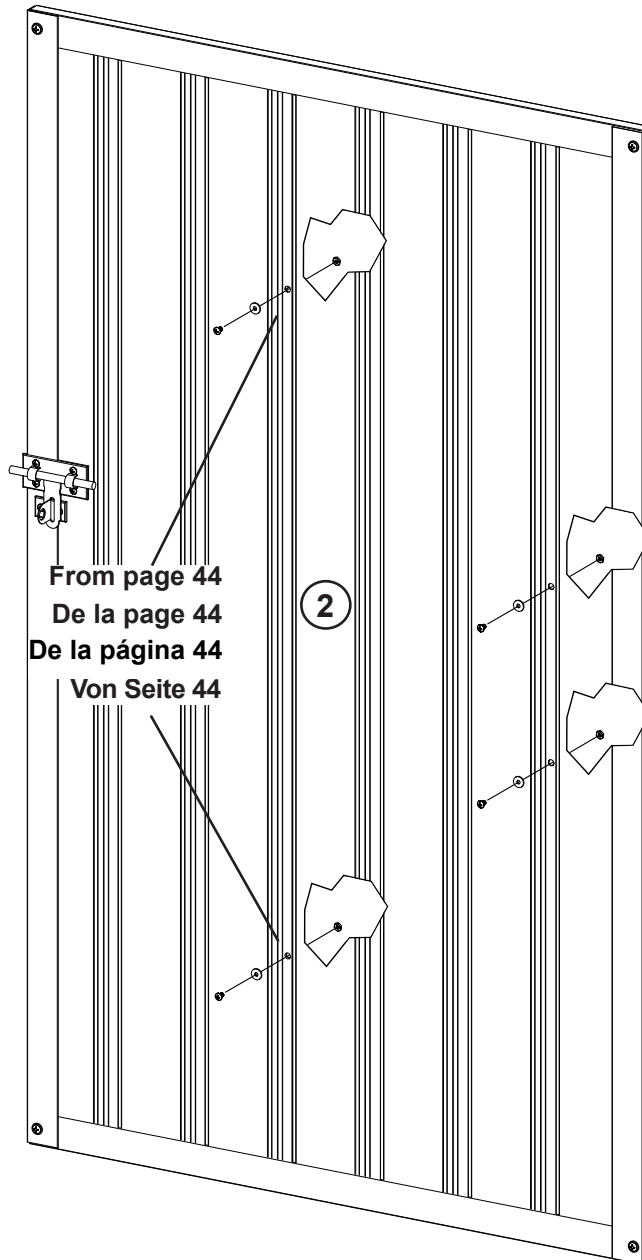

# Step 5 / Étape 5 / Paso 5 / Schritt 5

You will need for this page:

Nécessaire pour cette page:

Usted necesitará para esta página:

Für diese Seite brauchen Sie:

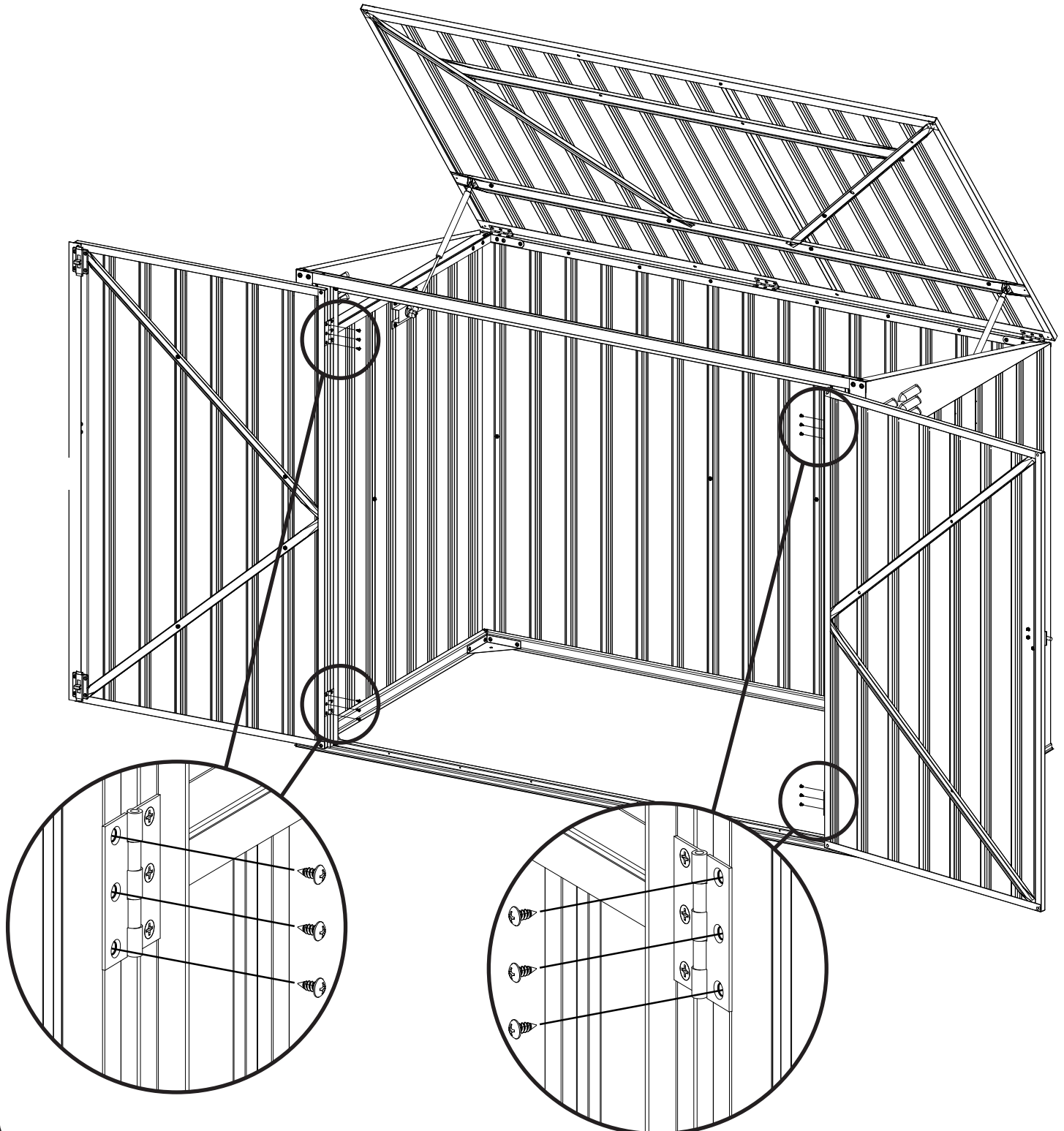
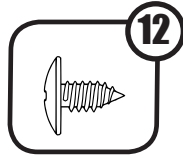

# Step 6 / Étape 6 / Paso 6 / Schritt 6

You will need for this page:

Nécessaire pour cette page:

Usted necesitará para esta página:

Für diese Seite brauchen Sie:

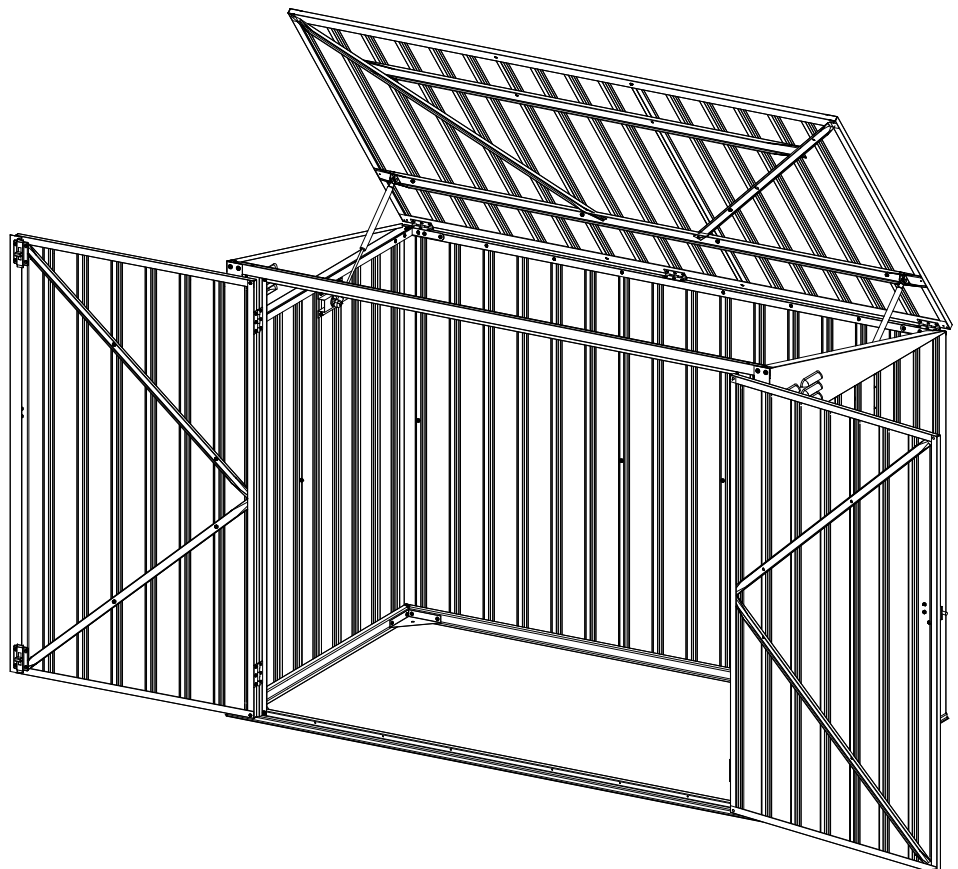
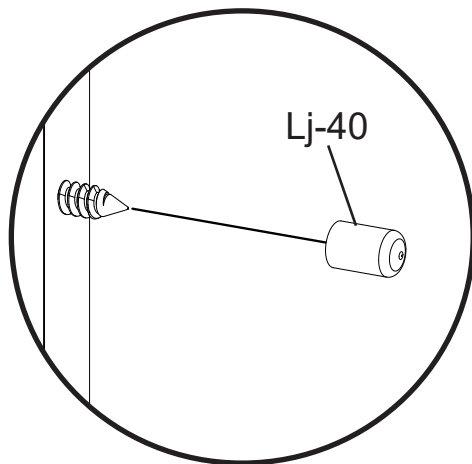
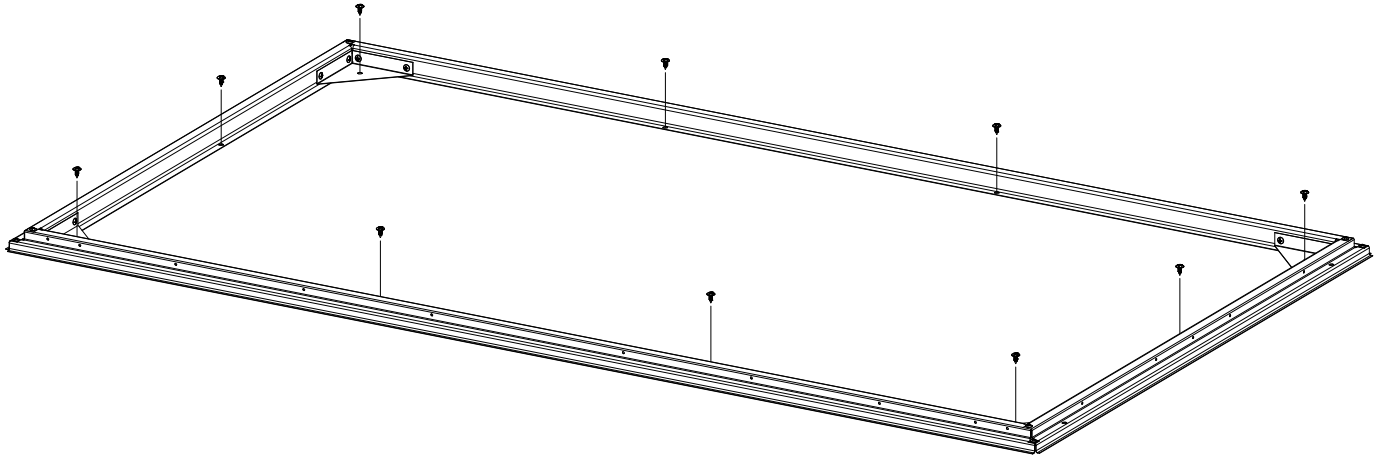
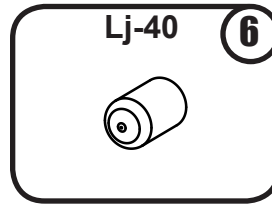
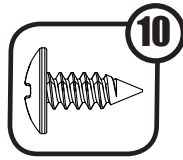

# Step 6 / Étape 6 / Paso 6 / Schritt 6

You will need for this page:

Nécessaire pour cette page:

Usted necesitará para esta página:

Für diese Seite brauchen Sie:

