

# Owner's Manual & Assembly Instructions

AJ01

Model No.      ED106     ED106L     ED106BS   
    SBVD106     WR106     WR106EU   
    VD106     VD106EU     VDGY106   
    VDGY106EU     697.68617

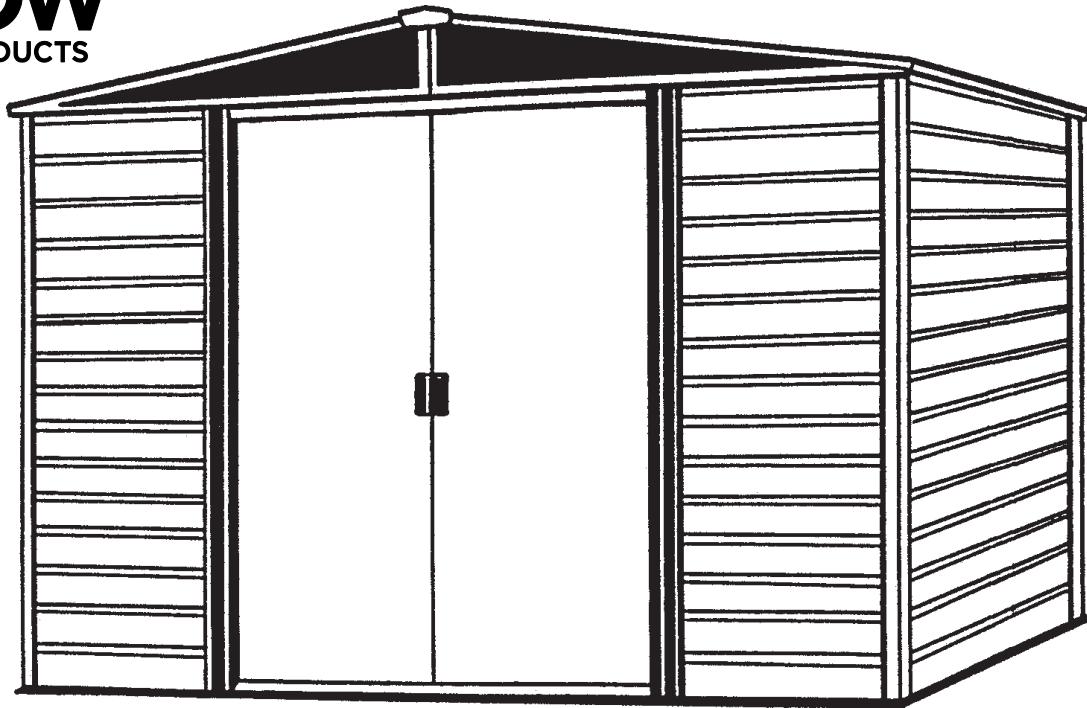

722920817

Storage Area:    54 Sq. Ft. 345 Cu. Ft.  
    5,0 m<sup>2</sup>            9,8 m<sup>3</sup>



CAUTION: SOME PARTS HAVE SHARP EDGES. CARE MUST BE TAKEN WHEN HANDLING THE VARIOUS PIECES TO AVOID A MISHAP. FOR SAFETY SAKE, PLEASE READ SAFETY INFORMATION PROVIDED IN THIS MANUAL BEFORE BEGINNING CONSTRUCTION. WEAR GLOVES WHEN HANDLING METAL PARTS.

BUILDING DIMENSIONS      \* Size rounded off to the nearest foot

| *Approx. Size | Base Size         | Exterior Dimensions<br>(Roof Edge to Roof Edge) |         |         | Interior Dimensions<br>(Wall to Wall) |         |         | Door Opening |         |
|---------------|-------------------|---|---------|---------|---------------------------------------|---------|---------|--------------|---------|
|               |                   | Width   | Depth   | Height  | Width                                 | Depth   | Height  | Width        | Height  |
| 10' x 6'      | 121" x 68 3/4"    | 123 1/4"  | 71 1/4" | 82 1/8" | 118 1/4"                              | 66"     | 80 7/8" | 55 1/2"      | 69 1/4" |
| 3,0m x 1,7m   | 307,3cm x 174,6cm | 313,1cm   | 181,0cm | 208,6cm | 300,4cm                               | 167,6cm | 205,4cm | 141,0cm      | 175,9cm |

- GB:** Assembly manual in additional languages available online.  
Scan QR code below to access.
- FR:** Manuel de montage disponible en ligne dans d'autres langues.  
Pour y accéder, scannez le code QR ci-dessous.
- SP:** Manual de montaje en idiomas adicionales disponible online.  
Escanee el código QR a continuación para acceder.
- DE:** Montageanleitung in zusätzlichen Sprachen online verfügbar.  
Scannen Sie den QR-Code unten, um darauf zuzugreifen.
- IT:** Manuale dell'assemblea in altre lingue disponibile online.  
Per accedere effettua la scansione del codice QR in basso.
- PT:** Manual de montagem disponível em outros idiomas online.  
Digitalize o código QR abaixo para obter acesso.
- DT:** Samlingshåndbog i yderligere sprog til rådighed online.  
Scan QR kode nedenunder for at få adgang.
- SK:** Na internete je k dispozícii návod na zostavenie v ďalších jazykoch.  
Dostanete sa k nemu naskenovaním kódu QR.
- CZ:** Návod k montáži v dalších jazycích je k dispozici v online verzi.  
Přístup získáte po naskenování QR kódu níže.
- HU:** Az összeszerelési útmutató további nyelveken is elérhető online.  
A hozzáféréshez olvassa be az alábbi QR-kódot.
- GR:** Υπάρχει διαθέσιμο στο διαδίκτυο το εγχειρίδιο συναρμολόγησης  
σε περισσότερες γλώσσες. Σαρώστε τον παρακάτω κώδικα  
QR για να αποκτήσετε πρόσβαση.



# BEFORE YOU BEGIN...

A03

## Owner's Manual

Before beginning construction, check local building codes regarding footings, location and other requirements. Study and understand this owner's manual.

Important information and helpful tips will make your construction easier and more enjoyable.

**Assembly Instructions:** Instructions are supplied in this manual and contain all appropriate information for your building model. Review all instructions before you begin, and during assembly, follow the step sequence carefully for successful results.

**Flooring and Anchoring:** Your storage building must be anchored to prevent wind damage. A base is necessary to construct a square and level building. Anchoring and base materials are not included with your building. We recommend the combined use of an Arrow Floor Frame Kit and an Arrow Anchoring Kit as an effective method of securing your building to the ground (Available at your local dealer, Arrow's website [arrowsheds.com](http://arrowsheds.com)) or you may construct a base and anchoring system of your choice. Your assembly instructions provide information on a few methods commonly used to secure and level a storage building.

**Parts and Parts List:** Check to be sure that you have all the necessary parts for your building.

- All part numbers can be found on the parts. All of these numbers (before the -) must agree with the numbers on the Parts List page.

- Separate contents of the carton by the part number while reviewing parts list. The first few steps show how to join related parts to make larger sub assemblies which will be used later.

- Familiarize yourself with the hardware and fasteners for easier use during construction. These are packaged within the carton. Note that extra fasteners have been supplied for your convenience.

# PLAN AHEAD....

A04

**Watch the Weather:** Be sure the day you select to install your building is dry and calm. Do not attempt to assemble your building on a windy day. Be careful on wet or muddy ground.

**Teamwork:** Whenever possible, two or more people should work together to assemble your building. One person can position parts or panels while the other is able to handle the fasteners and the tools.

**Tools and Materials:** These are some basic tools and materials you will need for the construction of your building. Decide which method of anchoring and the type of base you wish to use in order to form a complete list of the materials you will need.

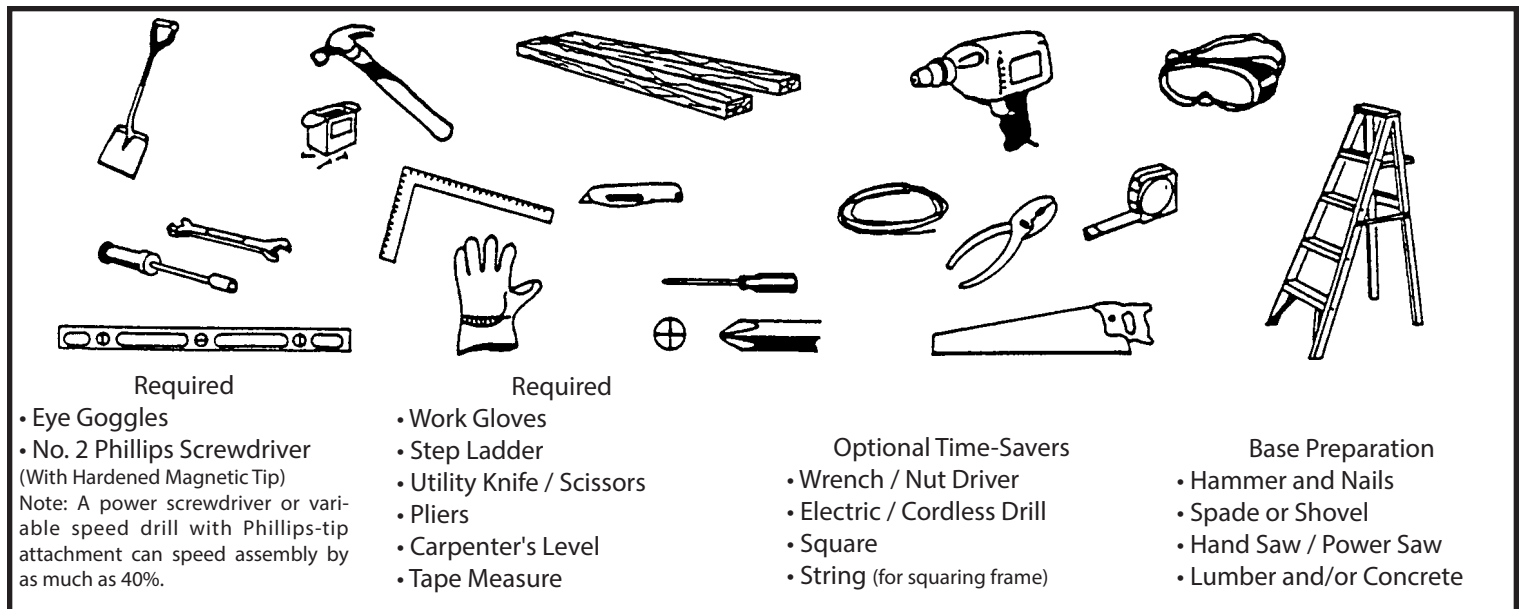

**Selecting and Preparing Your Site:** Before assembly, you will want to decide on a location for your building. The best location is a level area with good drainage.

- Allow enough working space for ease of moving parts into position during assembly. Be sure there will be enough space at entrance for doors to open fully and enough space around the building to be able to fasten the panel screws from the outside.

- Before you begin the first steps in assembling your parts, a base should be constructed and an anchoring system should be ready to use.

# SAFETY FIRST...

Safety precautions are important to follow throughout the construction of your building.

•Care must be taken when handling various pieces of your building since some contain sharp edges. Please wear work gloves, eye protection and long sleeves when assembling or performing any maintenance on your building.

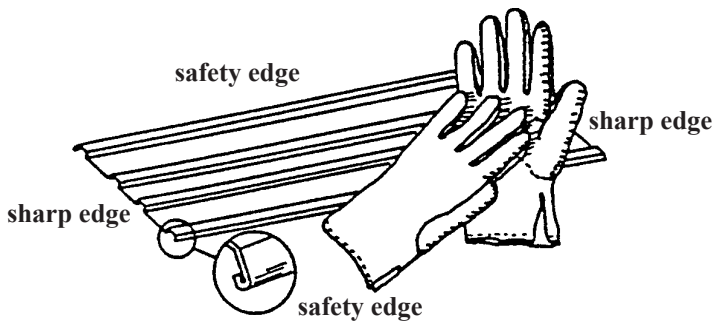

•Keep children and pets away from worksite to avoid distractions and any accidents which may occur.



•Never concentrate your total weight on the roof of the building. When using a step ladder make sure that it is fully open and on even ground before climbing on it.

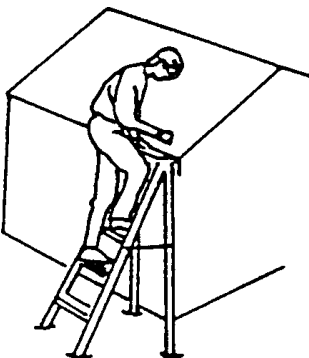

•Practice caution with the tools being used in the assembly of this building. Be familiar with the operation of all power tools.

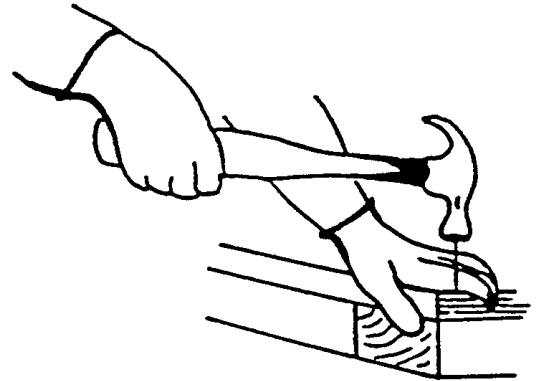

•Do not attempt to assemble the building if parts are missing because any building left partially assembled may be seriously damaged by light winds.

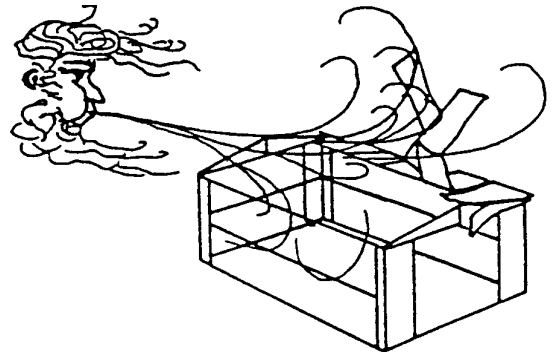

•Do not attempt to assemble the building on a windy day, because the large panels acting as a "sail", can be whipped about by the wind making construction difficult and unsafe.



# CARE & MAINTENANCE....

A06

**Finish:** For long lasting finish, periodically clean and wax the exterior surface. Touch-up scratches as soon as you notice them on your unit. Immediately clean the area with a wire brush; wash it and apply touch-up paint per manufacturer's recommendation.

**Roof:** Keep roof clear of leaves and snow with long handled, soft-bristled broom. Heavy amounts of snow on roof can damage building making it unsafe to enter. In snow country, Roof Strengthening Kits are available for most Arrow Buildings for added protection against heavy snow accumulation. Contact Arrow as outlined on the Ordering Accessories page to place an order.

**Doors:** Always keep the door tracks clear of dirt and other debris that prevent them from sliding easily. Lubricate door track annually with furniture polish or silicone spray. Keep doors closed and locked to prevent wind damage.

**Fasteners:** Use all washers supplied to protect against weather infiltration and to protect the metal from being scratched by screws. Regularly check your building for loose screws, bolts, nuts, etc. and retighten them as necessary.

**Moisture:** A plastic sheet (vapor barrier) placed under the entire floor area with good ventilation will reduce condensation.

## Other Tips....

- Wash off inked part numbers on coated panels with soap and water.
- Silicone caulking may be used for watertight seals throughout the building.

Do not store swimming pool chemicals in your building. Combustibles and corrosives must be stored in air tight approved containers.

Keep this Owner's Manual and Assembly Instructions for future reference.

# ACCESSORIES...

A07

## ROOF STRENGTHENING (heavy snow load) KITS

Extra roof beams and gable braces designed for added protection against heavy snow accumulation. Increases the strength of your roof.

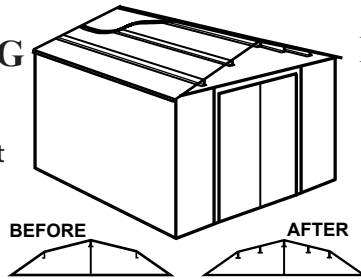

## ANCHOR KITS

### Model No. AK4

Anchor Kit contains heavy-duty steel augers, 60' (18 m) of steel cable and 4 cable clamps. No digging or concrete pouring, just insert cable under roof, over roof beams, into augers and twist augers into the ground. For buildings larger than 10'x9' (3,0 m x 2,6 m), use 2 kits.

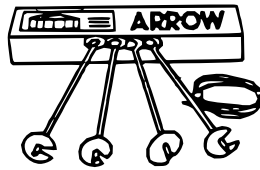

### Model No. AK100

New concrete anchor system permits anchoring any size Arrow building directly to a concrete slab. Each kit contains heavy-duty, hot-dipped galvanized steel corner gussets and perimeter clips which fit over the floor frame and lag bolt into a concrete slab. Full assembly instructions and a 1/4" masonry drill bit are included.

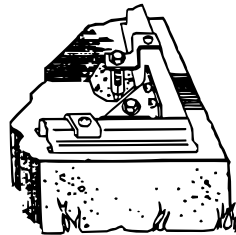

### Model No. AK600

Earth Anchor Kit anchors any size Arrow building to the ground. Each kit contains heavy duty, hot-dipped galvanized steel corner gussets and 4 earth anchors.

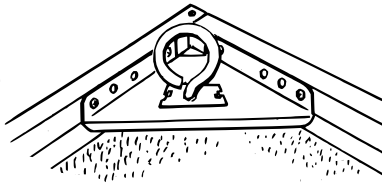

## TOOL HANGING RACK

### Model No. TH100

The perfect tool organizer. Twin 25 1/2" (64,8 cm) steel channels plus five heavy-duty snap-in hangers and a small tool holder for screwdrivers, pliers, etc. Holders slide along channel for fully adjustable spacing. Great for garage, basement, or the back of any door. Fits all Arrow storage buildings.

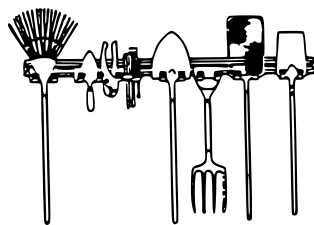

## FLOOR FRAME KITS

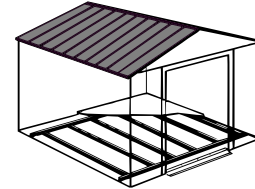

MODELS FB47410, FB5465, FB106-A  
FB109-A and FB1014-A

A simple new floor frame system made of heavy-duty, hot-dipped galvanized steel. Use as base for plywood, sand or stone.

## ATTIC KIT / WORKBENCH KIT

### Model No. AT101

Heavy-duty galvanized steel bars that fit all 10' (3,0 m) wide Arrow buildings. They install quickly and easily to help organize space and create more useable space as an attic or workbench. Will hold up to 250 lbs. (113 kg) evenly distributed.

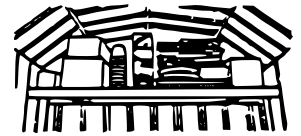

Some drilling required to fit buildings without mid-wall bracing.

## SHELF UNITS

Heavy-duty, galvanized steel shelf units help organize storage space. They easily mount on the wall or sit on the floor. Fits all Arrow buildings.\*

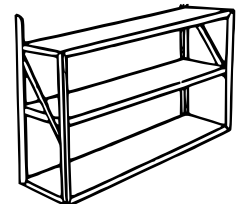
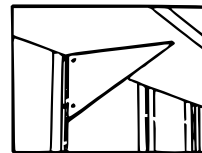
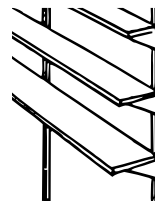

Model No. SS404

- Makes 8" to 12" (20,3-30,5 cm) wide shelves in any length.
- Brackets, braces, hardware included.
- Lumber is not included.

Model No. SS900-B

- Grey color
- 3 shelves
- Holds up to 85 lbs. (38 kg) (even weight distribution)

\* Some drilling required to fit buildings without mid-wall bracing.

# ORDERING ACCESSORIES....

A08

02/13

We recommend that you purchase accessory items from your local storage building dealer whenever possible; however, because the full line of accessories is not always available from all dealers, Arrow is offering them to you on a direct basis.

## SPECIAL NOTE:

If your accessory is shipped via truck line a day time phone number is required to arrange delivery. If no one is available to sign for the delivery, you may be subject to a re-delivery charge assessed by the carrier.



# Base

109

## The Base For Your Building

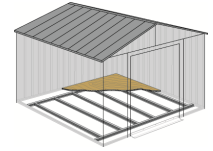

No matter which of the options below you choose for a base, an ARROW ANCHORING KIT is recommended as an effective method of properly securing your building after assembly is complete.

### OPTION 1: Directly on ground (earth)

Assemble your building directly on level ground (grass, dirt, rock, sand, etc.). If you choose this option Arrow has a simple kit available to provide a floor inside the shed to keep stored items off the ground. This kit can be used to support a plywood floor (wood not included) or be filled with sand/rock to provide a solid surface. (Order No. FB106-A or 68381-A)

Allow 1 - 2 hours for construction.

### OPTION 2: Wood Platform

If you decide to build your own base, be sure to select the appropriate materials.

These are the recommended materials for your base:

2 x 4's (38 mm x 89 mm) Pressure Treated Lumber

5/8" (15,5 mm) 4 x 8 (1220 mm x 2440 mm) Plywood-exterior grade NOTE: Pressure Treated Lumber must not be used where it will make contact with your storage building. The properties of Pressure Treated Lumber will cause accelerated corrosion.

If Pressure Treated Lumber comes in contact with your storage building your warranty will be voided.

10 & 4 penny Galvanized Nails Concrete Blocks (optional)

The platform should be level and flat (free of bumps, ridges etc.) to provide good support for the building. The necessary materials may be obtained from your local lumber yard.

To construct the base follow instructions and diagram.

Construct frame (using 10 penny galvanized nails)

Measure 16"/24" (40,6 cm/61,0 cm) sections to construct inside frame (see diagram)

Secure plywood to frame (using 4 penny galvanized nails)

Allow 6 - 7 hours for construction.

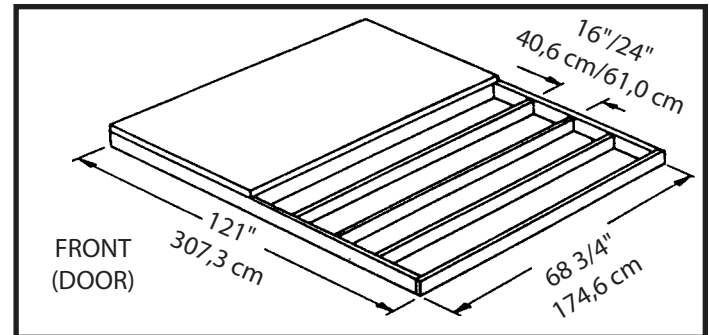

Note: Platform/Slab will extend 9/16" (1,4 cm) beyond floor frame on all four sides. Seal this 9/16" (1,4 cm) of wood with a roofing cement (not included), or bevel this 9/16" (1,4 cm) of concrete when pouring, for good water drainage.

### OPTION 3: Concrete Slab

The slab should be at least 4" (10,2 cm) thick. It must be level and flat to provide good support for the frame.

The following are the recommended materials for your base.

1 x 4's (19 mm x 89 mm) (will be removed once the concrete cures)

Concrete Sheet of 6 mil plastic

We recommend for a proper strength concrete to use a mix of:

1 part cement 3 parts pea sized gravel 2 1/2 parts clean sand

Prepare the Site/Construct a Base

1. Dig a square, 6" (15,2 cm) deep into the ground (remove grass).
2. Fill up to 4" (10,2 cm) in the square with gravel and tamp firm.
3. Cover gravel with a sheet of 6 mil plastic.
4. Construct a wood frame using four planks of 1x4 (19 mm x 89 mm) lumber.
5. Pour in concrete to fill in the hole and the frame giving a total of 4" (10,2 cm) thick concrete. Be sure surface is level.

Allow 3 - 5 hours for construction and a week for concrete curing time.

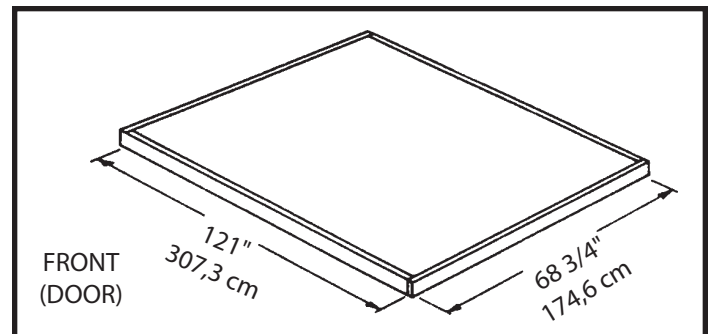

Note: Finished Slab dimensions, with lumber removed.

# Anchoring

A10

## Anchoring Down The Building

It is important that the entire floor frame be anchored after the building is erected.

Below are recommended ways of anchoring.

### Arrow Anchoring Kit: (Model No. AK4 or 60298)

Recommended for use with any suggested base.

Contains: 4 Anchors with Cable, Clamps and installation instruction.

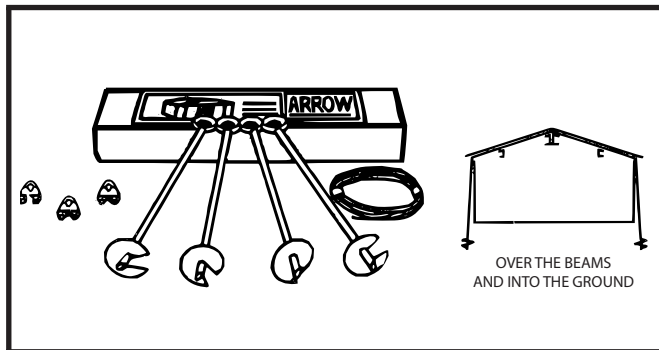

### Anchoring into Wood/Post:

Use 1/4" (6 mm) Wood Screws. There are 1/4" (6 mm) dia. holes provided in the frames for proper anchoring.

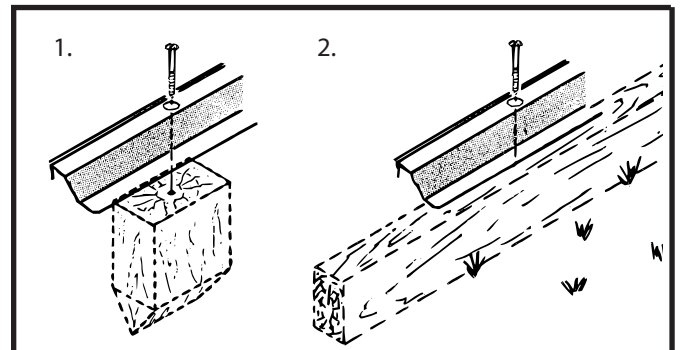

### Arrow Anchoring Kit: (Model No. AK100 or 68383)

Recommended for use with the concrete base.

Contains: Corner gussets, perimeter clips, hardware, 1/4" masonry drill bit and installation instruction.

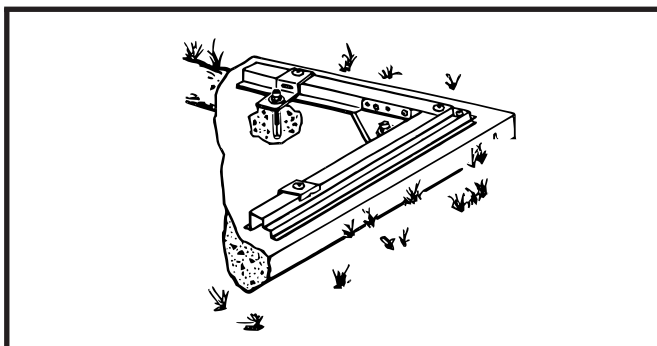

### Anchoring into Concrete:

1. For poured concrete slab or footing or patio blocks: Use 1/4" x 2" (6 mm x 51 mm) Lag Screws.
2. For Anchor Post of Concrete poured after building is erected: Use 1/4" x 6" (6 mm x 152 mm) Lag Screws.

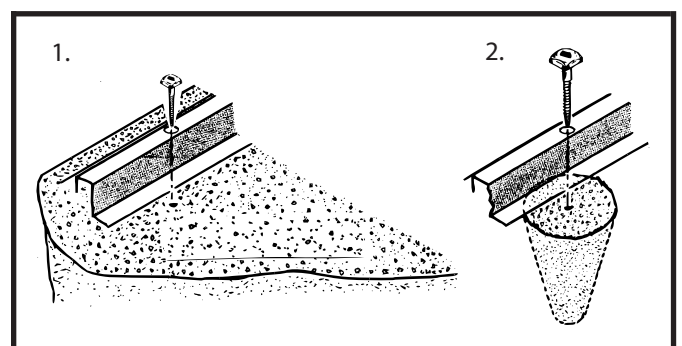

# Hardware

PN11

Remove from bag of screws  
and save for the last step



65103  
#8-32 Hex Nut (89)



65900A  
#10Bx1/2" (13 mm)  
Black Screw (8)  
(Packed with Screws)



65923  
#8-32x3/8" (10 mm)  
Bolt (89)



65004  
#8Ax5/16" (8 mm)  
Screw (284)

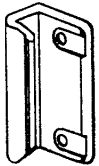

66045  
Handle (2)

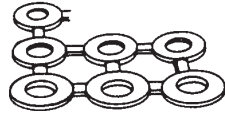

66646  
Washer (166)  
(5 sheets of 40)

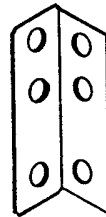

5971  
Roof Beam Bracket (4)

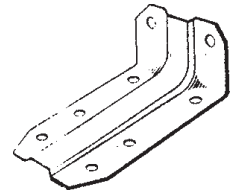

6228  
Track Support (2)



66769  
Door Slide (4)

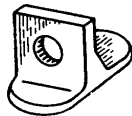

66382  
Lower Door Guide (4)

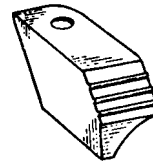

66183  
Roof Trim Cap  
(2 right & 2 left)



67468  
Peak Cap (2)

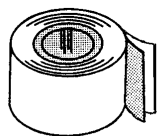

67293  
Weather Stripping (1)

# Parts List

AJ12

| Assembly Key No. | Part Number | Part Description      | Quantity in Carton | Check List |
|------------------|-------------|-----------------------|--------------------|------------|
| 1                | 8934        | Ramp                  | 1                  |            |
| 2                | 9367        | Front Floor Frame     | 2                  |            |
| 3                | 8936        | Rear Floor Frame      | 2                  |            |
| 4                | 9338        | Right Rear Wall Angle | 1                  |            |
| 5                | 9366        | Door Track            | 2                  |            |
| 6                | 6403        | Door Track Splice     | 1                  |            |
| 7                | 9339        | Left Rear Wall Angle  | 1                  |            |
| 8                | 6001        | Left Gable            | 2                  |            |
| 9                | 6000        | Right Gable           | 2                  |            |
| 10               | 8946        | Side Floor Frame      | 2                  |            |
| 11               | 5288        | Corner Post           | 4                  |            |
| 12               | 9365        | Front Wall Channel    | 2                  |            |
| 13               | 9342        | Side Wall Angle       | 2                  |            |
| 14               | 5287        | Splice Post           | 1                  |            |
| 15               | 7311        | Door Jamb             | 2                  |            |
| 16               | 9344        | Siding Stud           | 6                  |            |
| 17               | 8719        | Side Siding           | 6                  |            |
| 18               | 6635        | Gable Brace           | 2                  |            |
| 19               | 8736        | Rear Siding           | 6                  |            |
| 20               | 8737        | Front Siding          | 6                  |            |
| 21               | 8474        | Roof Beam             | 3                  |            |
| 22               | 8476        | Side Wall Angle       | 1                  |            |
| 23               | 8468        | Right Roof Panel      | 2                  |            |
| 24               | 6529        | Roof Panel            | 4                  |            |
| 25               | 8469        | Left Roof Panel       | 2                  |            |
| 26               | 8461        | Ridge Cap             | 1                  |            |
| 27               | 8482        | Side Roof Trim        | 2                  |            |
| 28               | 10472       | Right Door            | 1                  |            |
| 29               | 10472       | Left Door             | 1                  |            |
| 30               | 10497       | Horizontal Door Brace | 4                  |            |
| 31               | 6301        | Vertical Door Brace   | 2                  |            |
| 32               | 3719        | Door Handle Brace     | 2                  |            |
| 33               | 69835       | Edge Trim (Green)     | 4                  |            |

# Assembly by Key No.

AJ13

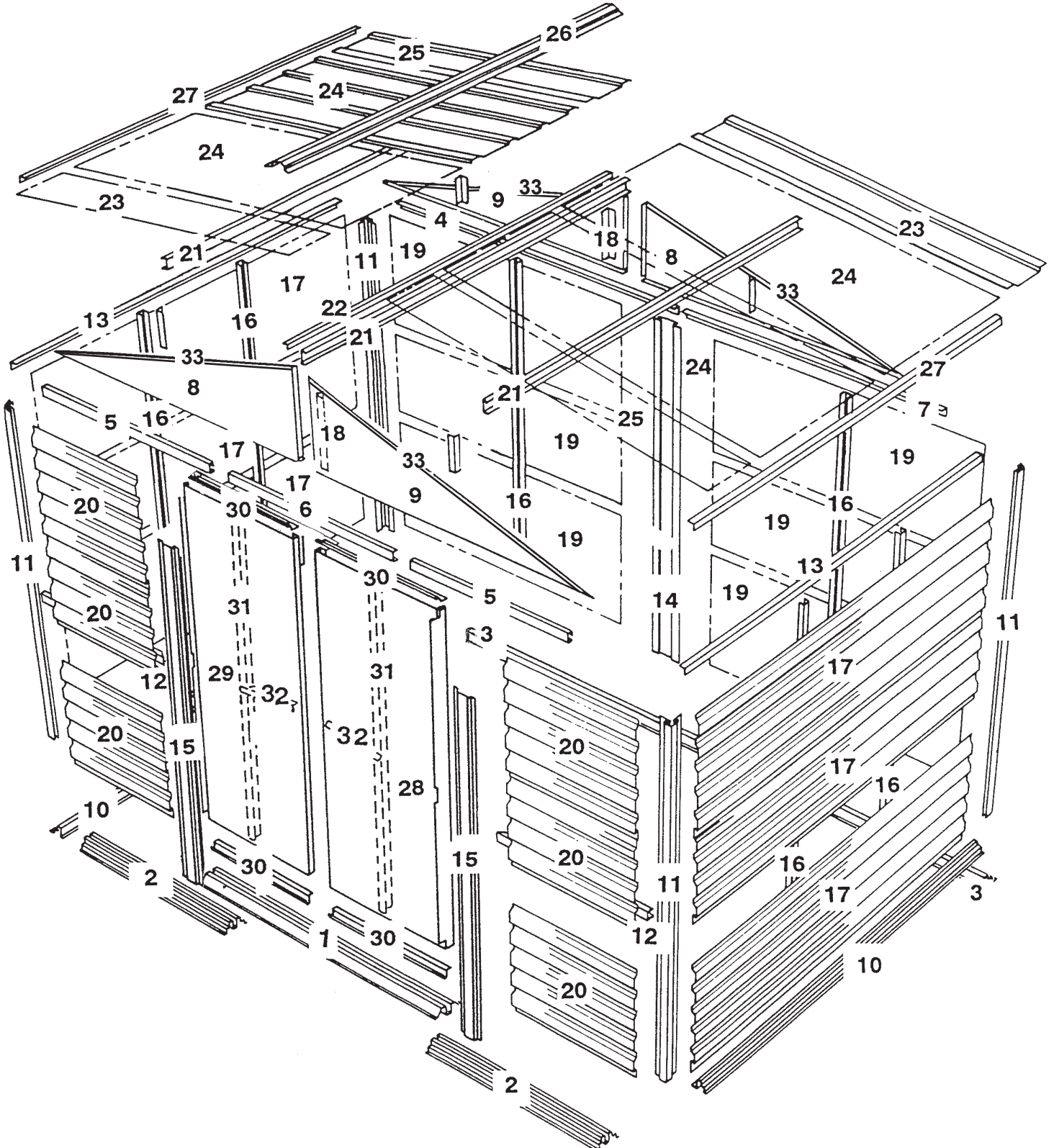

# Step 1

Q14

## Parts Needed For Floor Frame Assemblies

8934 Ramp (1)  
9367 Front Floor Frame (2)  
8936 Rear Floor Frame (2)

The front floor frame is made up of three pieces. The rear floor frame is made up of two pieces. The holes in these pieces will align when the pieces are positioned with correct amount of overlap. The illustrations below show the proper overall length for the front and rear. Proceed as follows:

**1** Place the front floor frames as shown. Center the ramp, with drain holes facing outside, on top of the two front floor frames. Join the frames by inserting eight screws.

**2** Overlap the rear floor frames as shown. The holes in these pieces will align when the pieces are positioned with correct amount of overlap. See the illustrations below for the proper overall length of the rear floor frame. Join the frames by inserting five bolts into frame set as shown.

**3** Double check the length of each and set these pieces aside for later use.

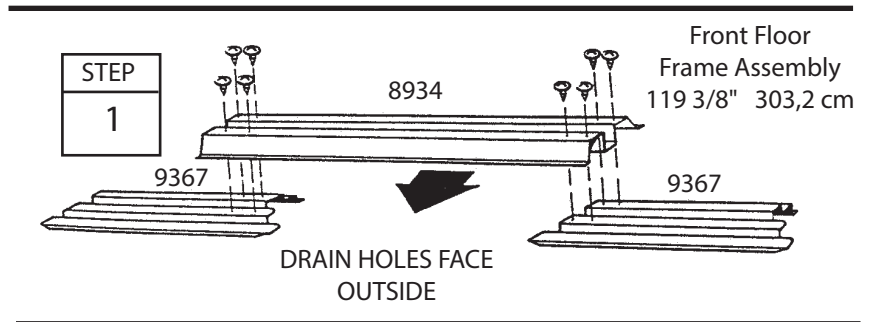
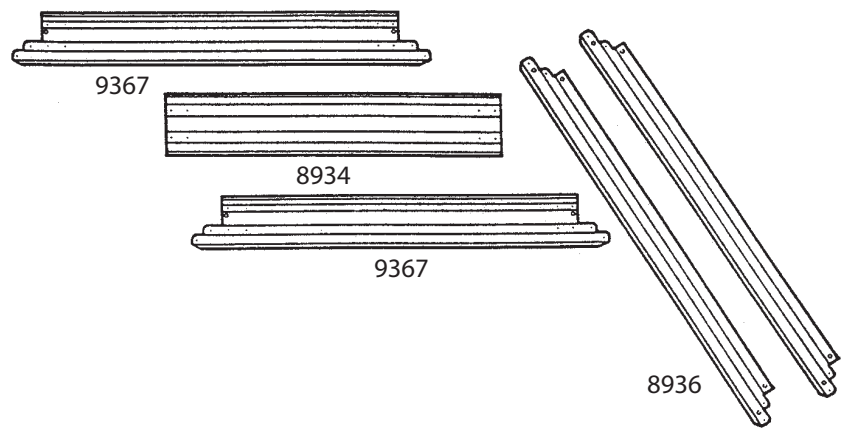

**STEP 2**

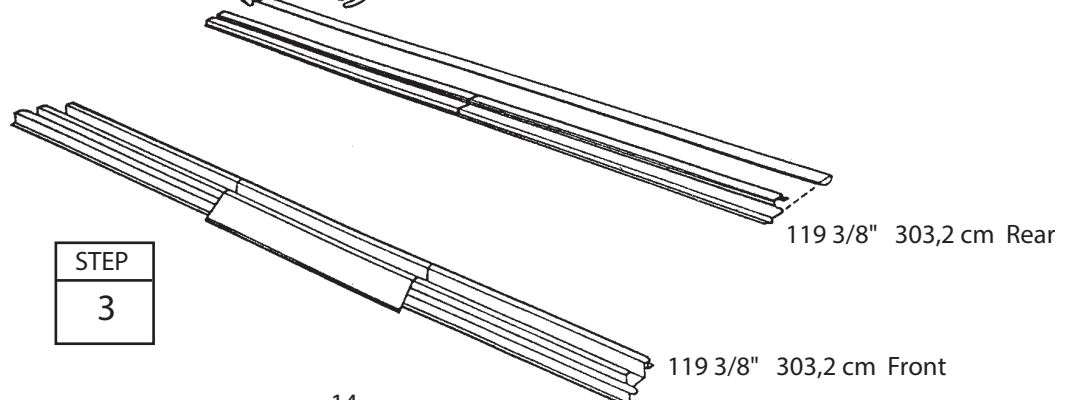
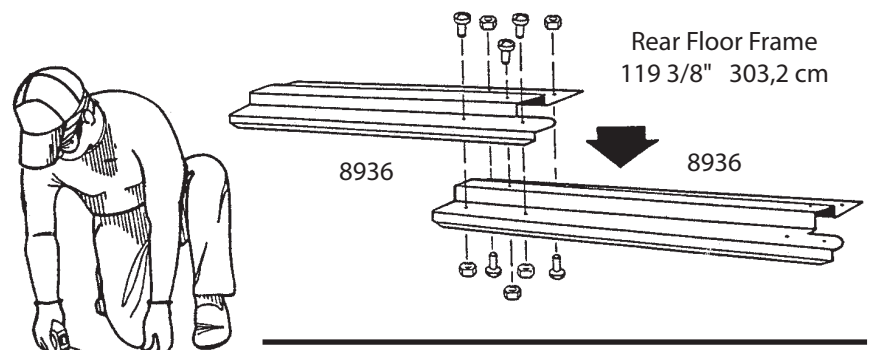

# Step 2

X15

## Parts Needed For Frame Assembly

9338 Right Rear Wall Angle (1)  
9339 Left Rear Wall Angle (1)

The main frame pieces reinforce the walls. This piece will later be installed at the top edge of the rear wall. Proceed as follows:

1 Overlap the right and left rear wall angle pieces as shown in the figure and fasten them together with one bolt in the center hole.

2 Set the assembly aside. You will use it later.

STEP

1

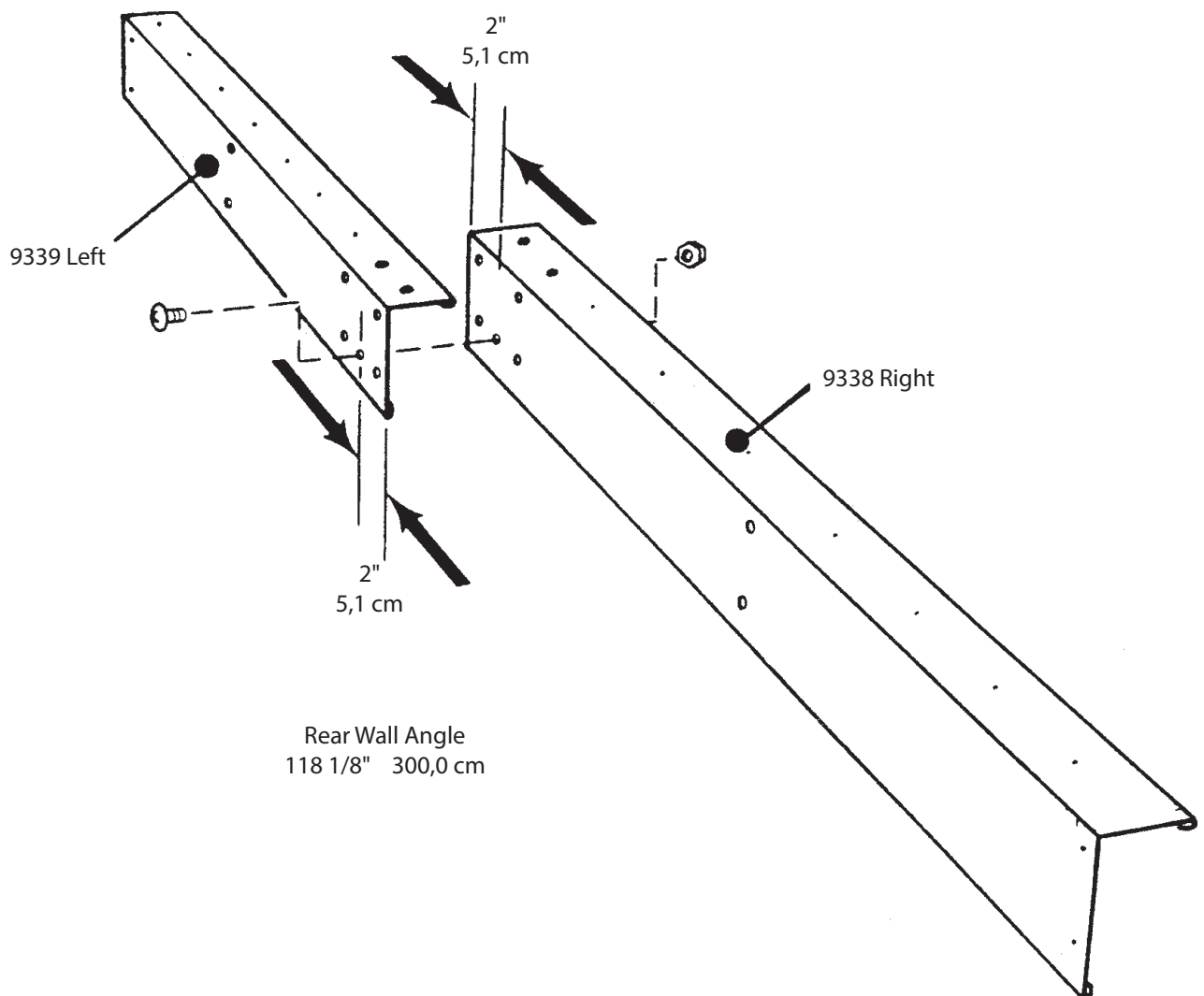

# Step 3

B16

## Parts Needed For Roof Beam Assembly

8474 Roof Beam (1)  
8476 Side Wall Angle (1)

The roof beams join the two gables and support the roof panels. The main roof beam is made up of two pieces fastened together.

1 Place the side wall angle, back-to-back, with a roof beam and fasten together using ten screws.

2 Set this piece aside for later use.

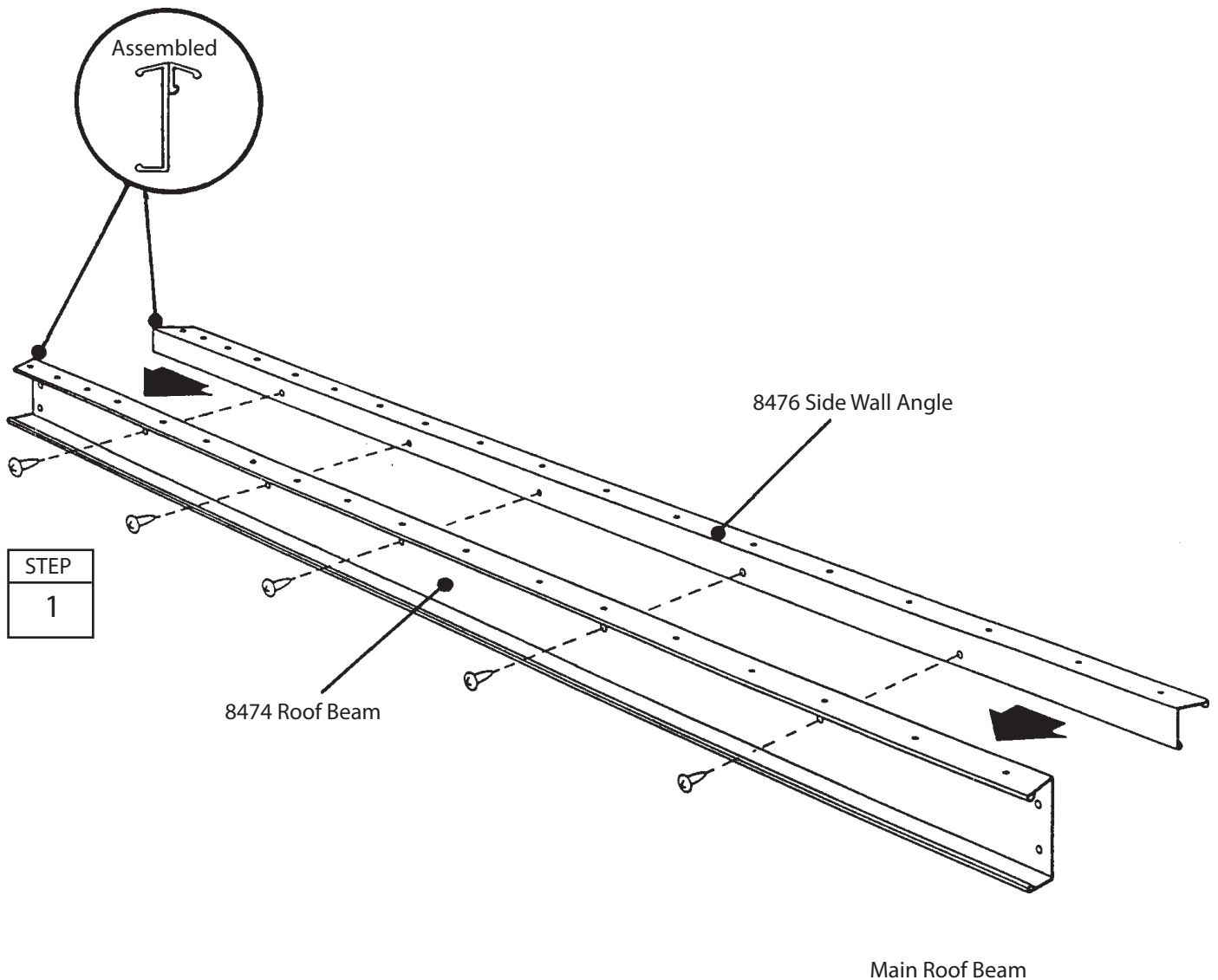



# Step 4

A17

## Parts Needed For Door Track Assembly

6403 Door Track Splice (1)  
9366 Door Track (2)

The door track assembly supports the sliding doors and reinforces the front wall. It is made up of three pieces.

1 Using the door track splice, (painted), join the door track (galvanized) pieces end-to-end as shown.

2 Insert four screws from the under-side only.

Hint: The holes in the top side of the door track assembly are for fastening the gable to the top of the front wall in a later step.

3 Position door slides onto the legs, from the end of door track assembly, as shown in the end view.

4 Set this piece aside for later use.

NOTE:  
Door Track Splice (painted part)

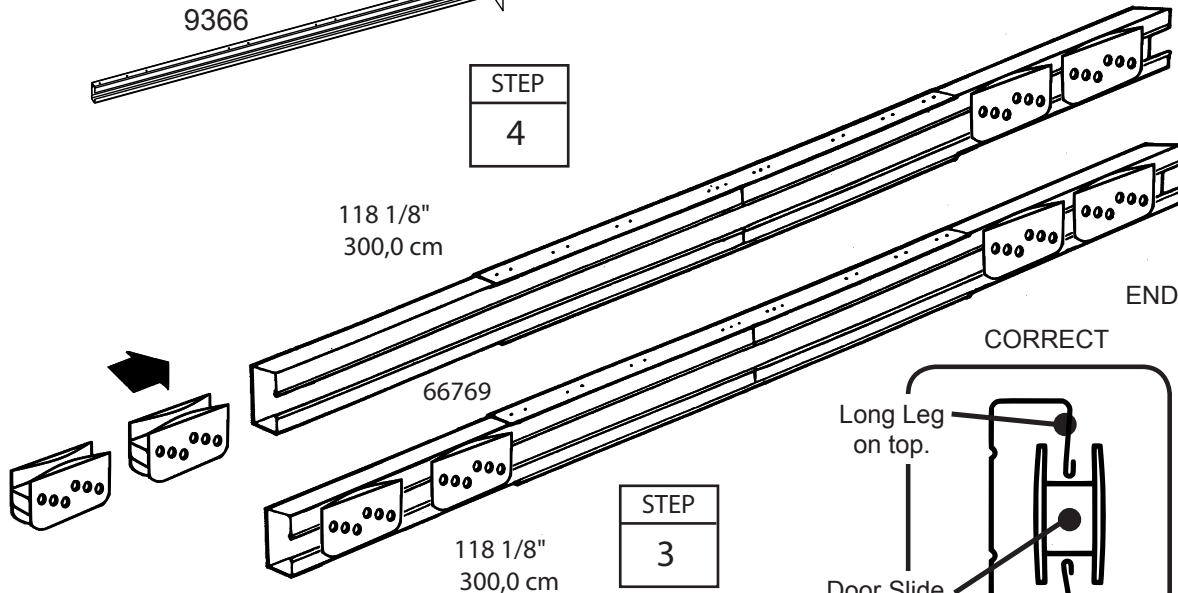
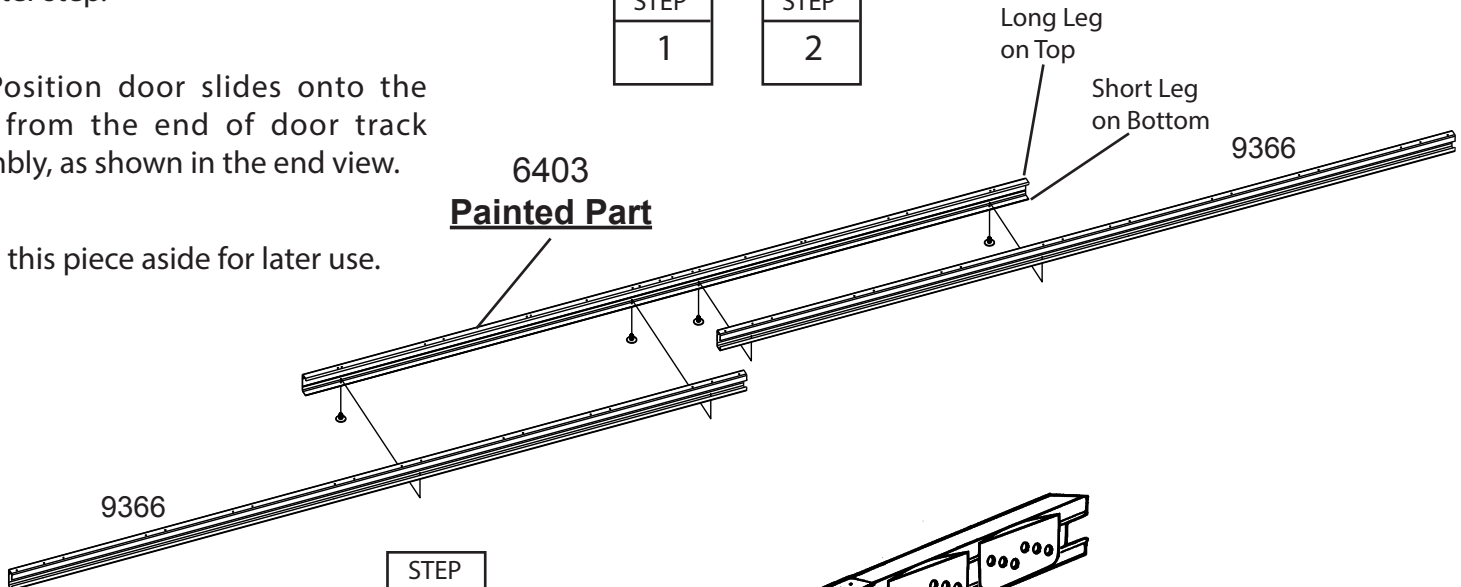
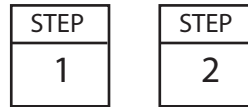
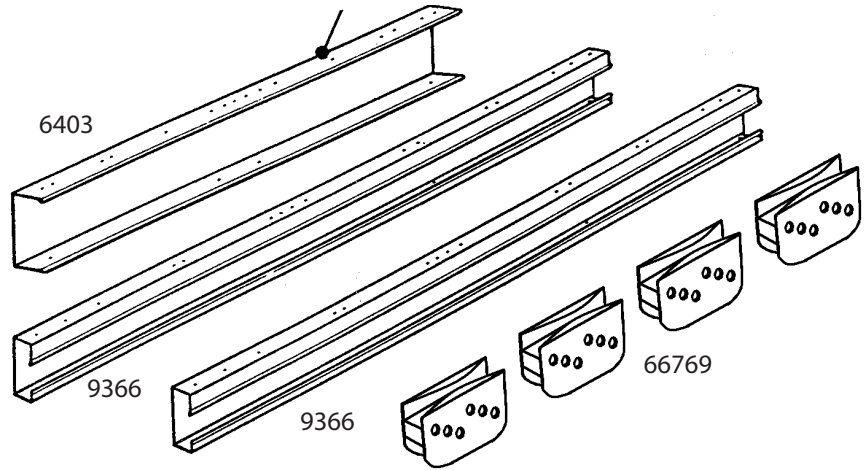

END VIEW

CORRECT

INCORRECT

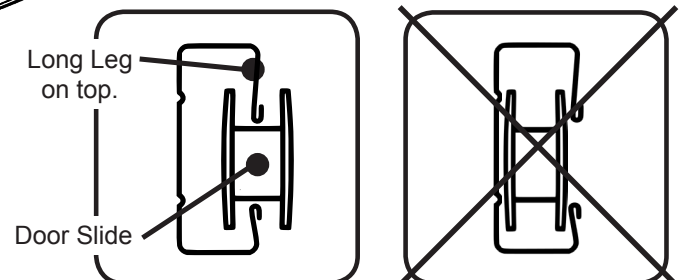

# Step 5

118

## Parts Needed For Floor Frame

Front Floor Assembly (1)  
8946 Side Floor Frame (2)  
Rear Floor Assembly (1)

1 Assemble the four corners of the floor frame using two screws at each corner as shown. At the front corners fasten bolts through from the bottom with nuts on top.

|      |
|------|
| STEP |
| 1    |

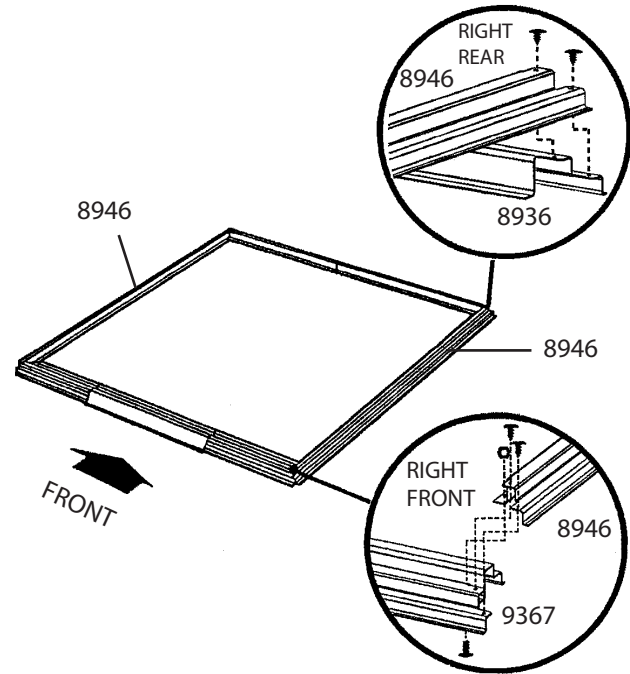

2 Measure the floor frame diagonally. When the diagonal measurements are equal, the floor frame is square.

### NOTE

If using a wood platform or concrete slab do not fasten the floor frames to your base at this time. You will anchor the building after it is erected.

When Diagonal Measurements are Equal the Floor Frame is Square.

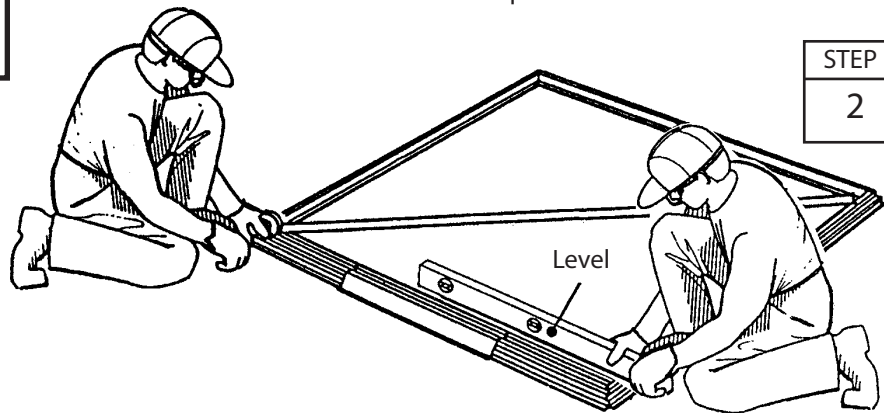

The floor frame must be square and level or holes will not align.

# Step 6

X19

## Parts Needed For Posts/Top Frames

5288 Corner Post (4)  
Door Track Assembly (1)  
Rear Wall Angle Assembly (1)  
9342 Side Wall Angle (2)

### NOTE

The remainder of the building assembly requires many hours and more than one person. Do not continue beyond this point if you do not have enough time to complete the assembly today. A partially assembled building can be severely damaged by light winds.

The top frame pieces give rigidity to the side walls and provide a surface for attaching the gables which support the roof.

**1** Position corner posts at the corner of the floor frame as shown. Fasten the corner post to the floor frame with two screws.

Support the corner posts with stakes or other devices until door jambs are attached.

**2** Fasten the door track assembly (holes on top) behind the top of the front corner posts using 1 screw in each corner. See the figure.

**3** Fasten the rear wall angle assembly behind the top of the rear posts using 2 screws in each post.

**4** Fasten the side wall angles behind the top of the side posts using 2 screws in each corner. Side wall angles overlap rear wall angle in corners.

The floor frame must be square and level or holes will not align.

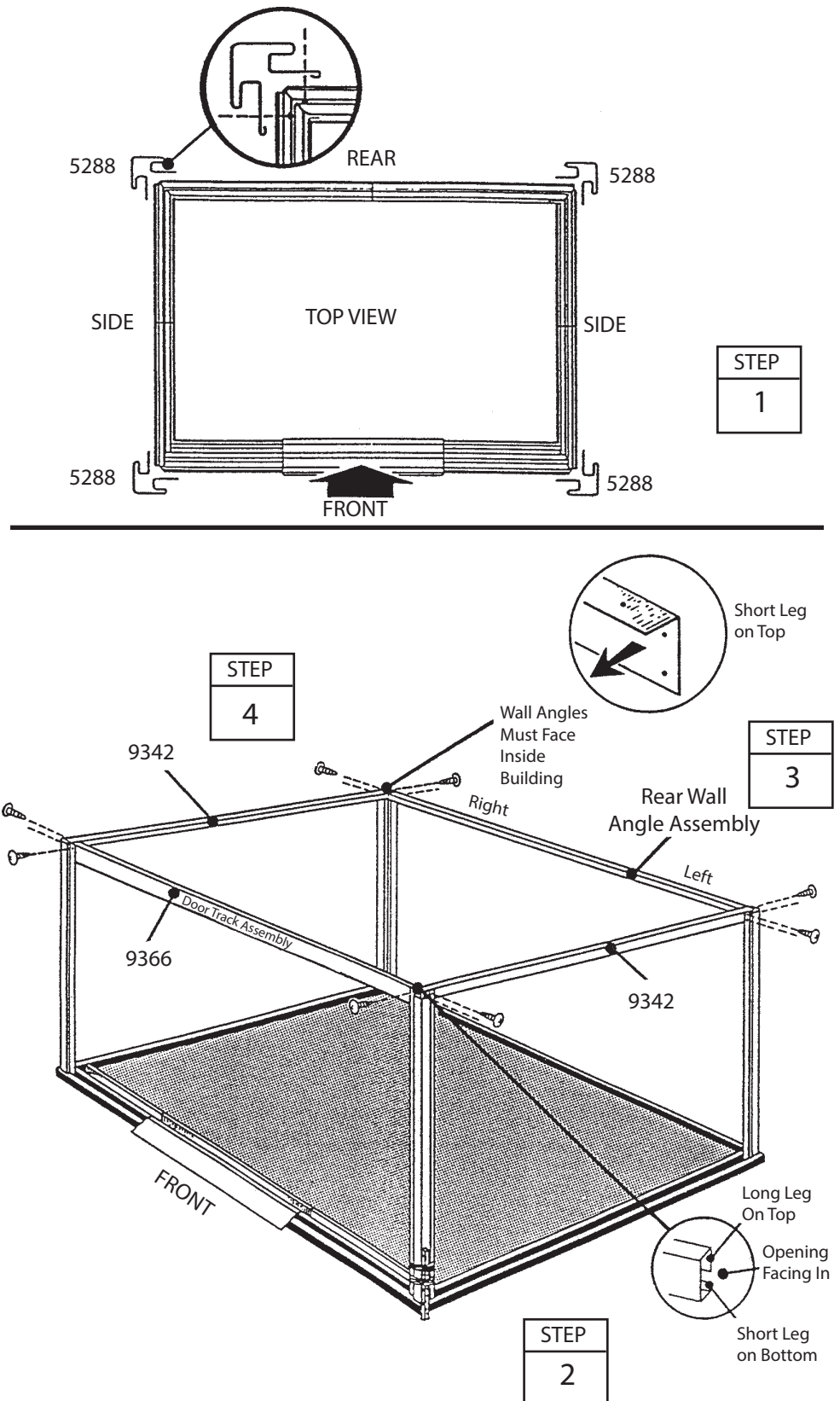

# Step 7

X20

## Parts Needed For Splice Post/Door Jamb

5287 Splice Post (1)  
7311 Door Jamb (2)

STEP

1

The door jambs reinforce the door opening and provide an attractive trim. The splice post supports the rear wall.

**1** Position splice post at the center of the rear wall and fasten using 4 bolts and nuts into rear wall angle and 2 screws into rear floor frame.

Hint: Measure or count holes to determine if post is centered on rear.

**2** Fasten the top of the door jambs to the door track with two screws. Do the same for the bottom into frame. Notched edge faces toward center of building.

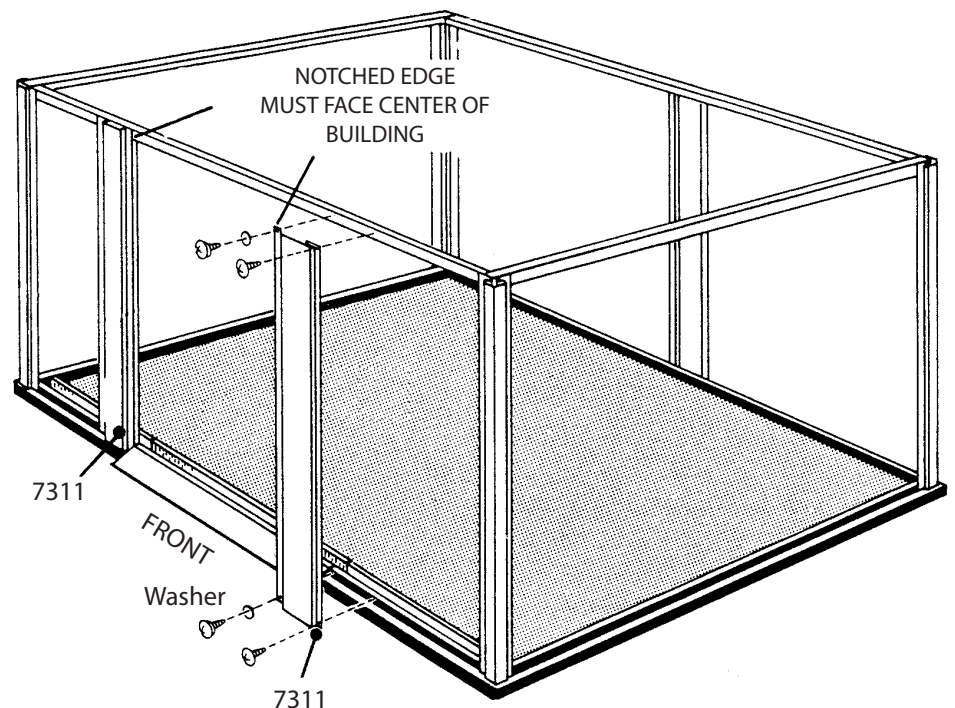
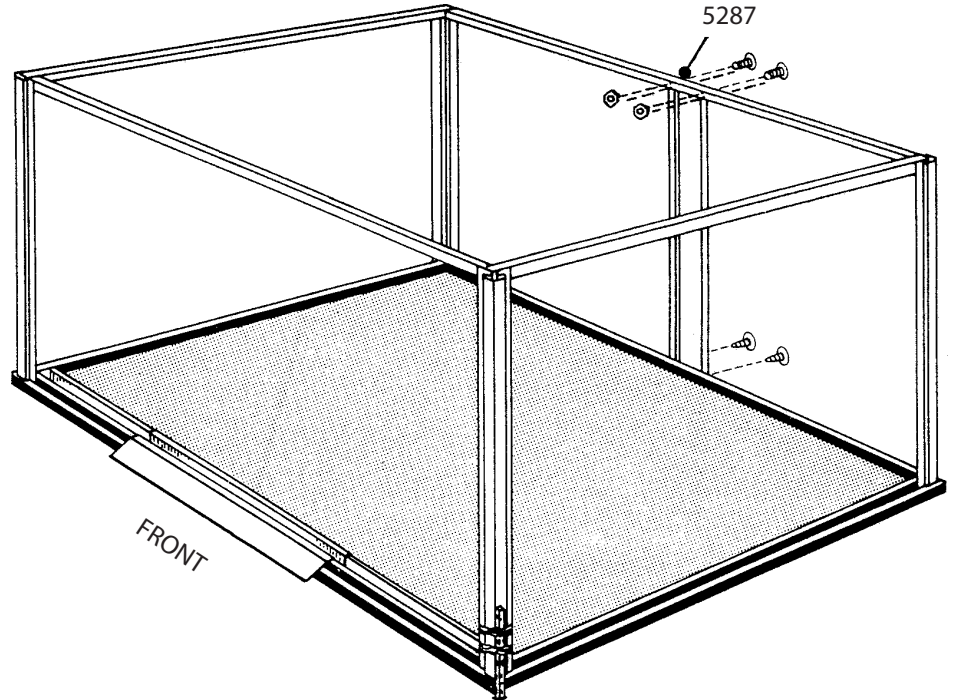

STEP

2

# Step 8

X21

## Parts Needed For Studs/Front Channel

9344 Siding Stud (6)  
9365 Front Wall Channel (2)

The studs provide a surface for attaching the siding panels.

**1** Following dimensions, measuring from the ends of angles, place a stud between each corner and splice post at the rear of building and 2 studs between corner posts at the sides. Position stud inside top angle and fasten with a screw at the lower hole.

**2** Rest bottom tab (large hole) outside floor frame. Do not fasten tab at this time. Repeat procedure for the remaining studs around the building.

**3** Place front wall channel into position behind corner post and door jamb. Fasten using three screws.

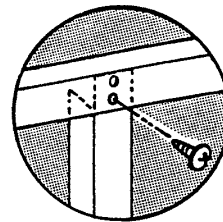

FASTEN STUD AT  
LOWER HOLE

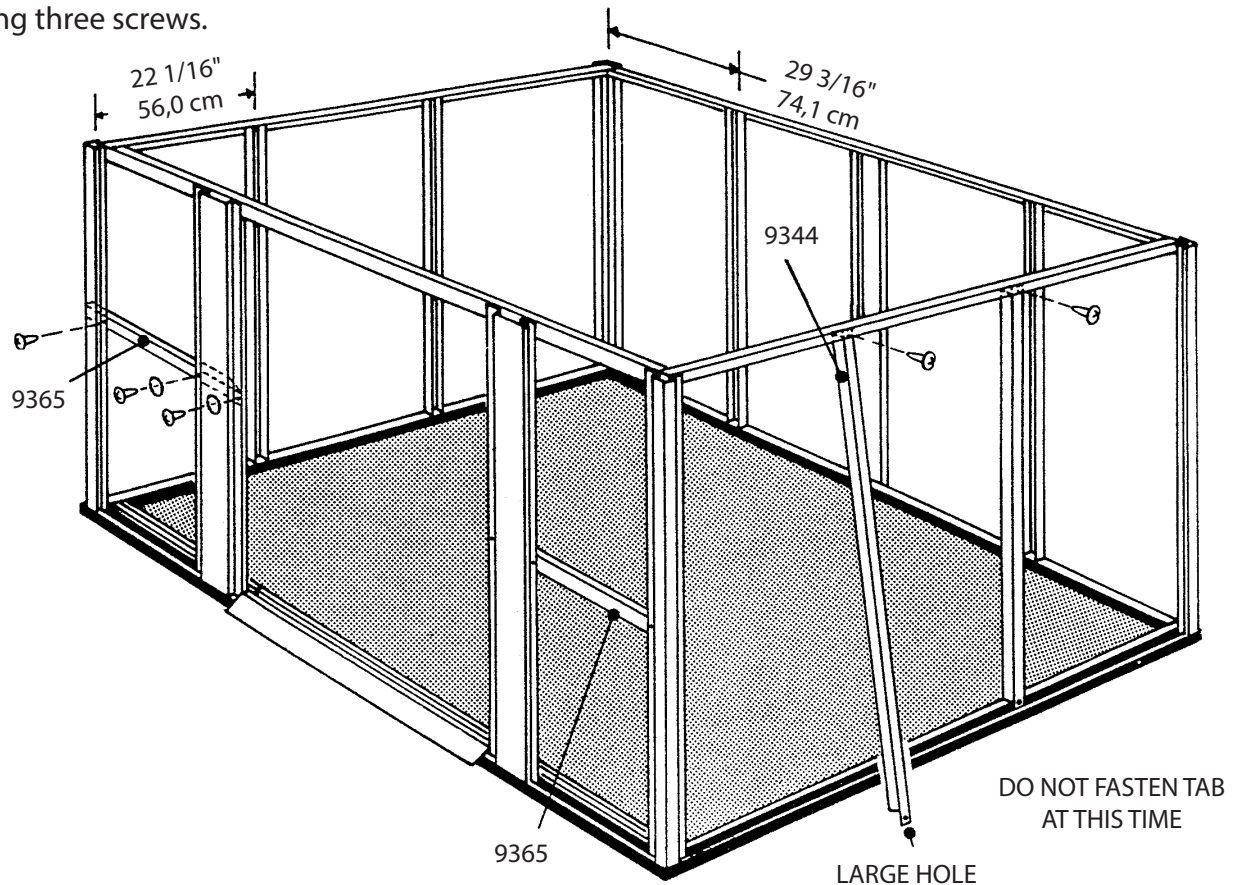

# Step 9

X22

## Parts Needed For Side Siding

8719 Side Siding (6)

Each screw in the wall requires a washer.



CORRECT



INCORRECT

**1** Slide side siding into channels of corner posts, flat edge upward, bottom edge down resting on floor frame. Always follow this pattern. Fasten bottom edge and tab of stud to floor frame using screws. Fasten center to stud with screws. Do not fasten flat edge yet.

**2** Install side siding as before. Note how the slot in bottom edge must overlap flat edge of last siding. Fasten both siding panels to stud at this overlap.

**3** Install side siding to the top as before.

**4** From inside building, fasten siding to corner posts using screws.

**5** Repeat steps 1 through 4 for opposite side of building.

### NOTE

Be careful to install the correct panel in each position as shown.

The floor frame must be square and level or holes will not align.

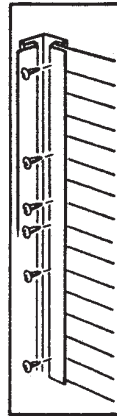

STEP  
4

STEP  
3

STEP  
2

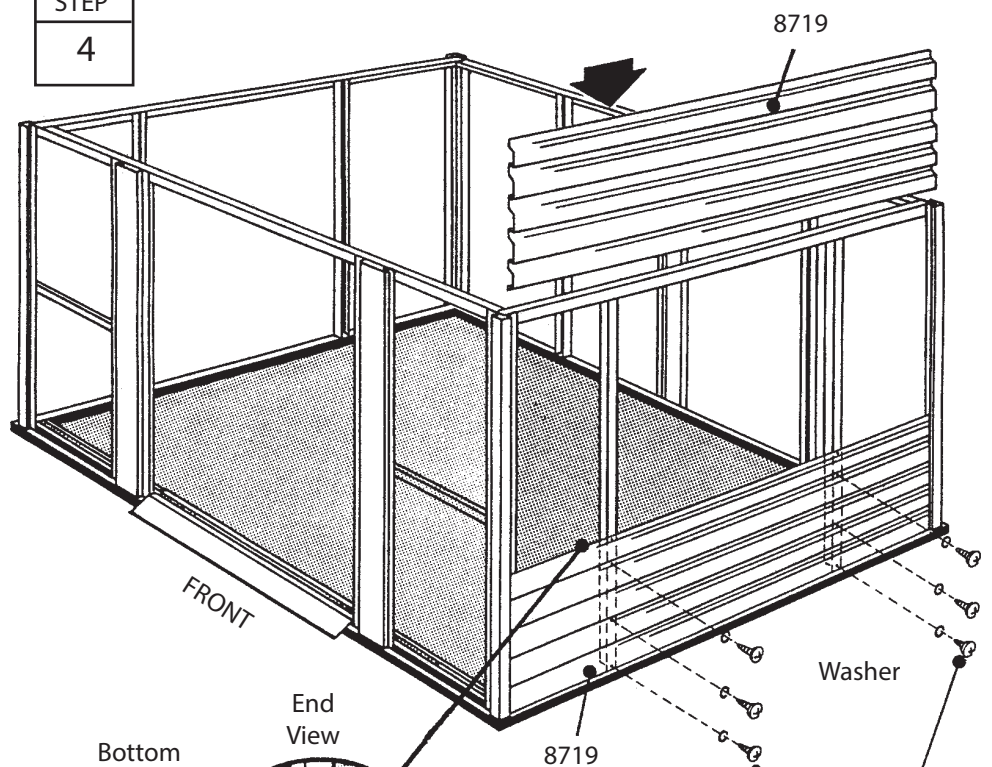

THIS SCREW MUST FASTEN TAB OF STUD

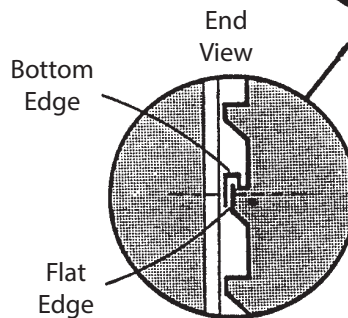

STEP  
1

# Step 10

X23

## Parts Needed For Rear/Front Siding

8736 Rear Siding (6)

8737 Front Siding (6)

1 Slide rear siding into channel of corner and splice posts fastening to rear frame as shown in previous step 9.

2 Install rear siding to complete each section of rear wall. Fasten top center of last siding to rear angle.

3 Slide front siding into channels of corner post and door jamb. This siding is fastened from the inside, using screws into post and jamb.

4 Install front siding to complete both front sections.

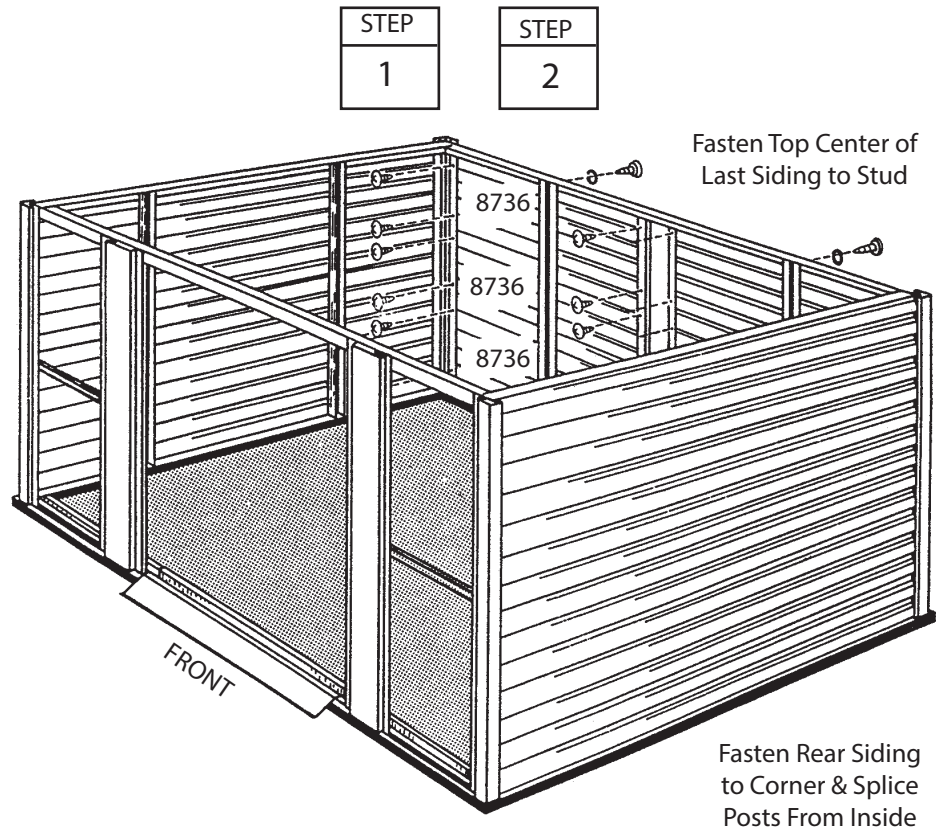

Front Panels Fasten  
at Corners & Door  
Jambs from the Inside

# Step 11

Y24et ctr

## Parts Needed For Gable Assemblies

- 6000 Right Gable (2)
- 6001 Left Gable (2)
- 5971 Roof Beam Bracket (4)

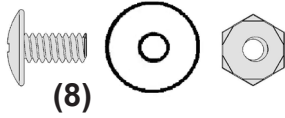

The gables go on top of the front and rear walls to support the roof beams.

### NOTE

The gables are packed nested together and might be mistaken as one piece. Carefully separate them before continuing.

**1** Apply **edge trim** to the top edge of the **right gables** and **left gables**.

**2** Attach the four **roof beam brackets** to the gables using two bolts, washers and nuts.

### NOTE

Mounting leg of bracket must face toward center of gable and holes closest together must be on top



### CAUTION:

To avoid mishap on the sharp edge the edge trim must remain in place on the top edge of the gable until right and left roof panels are in place.

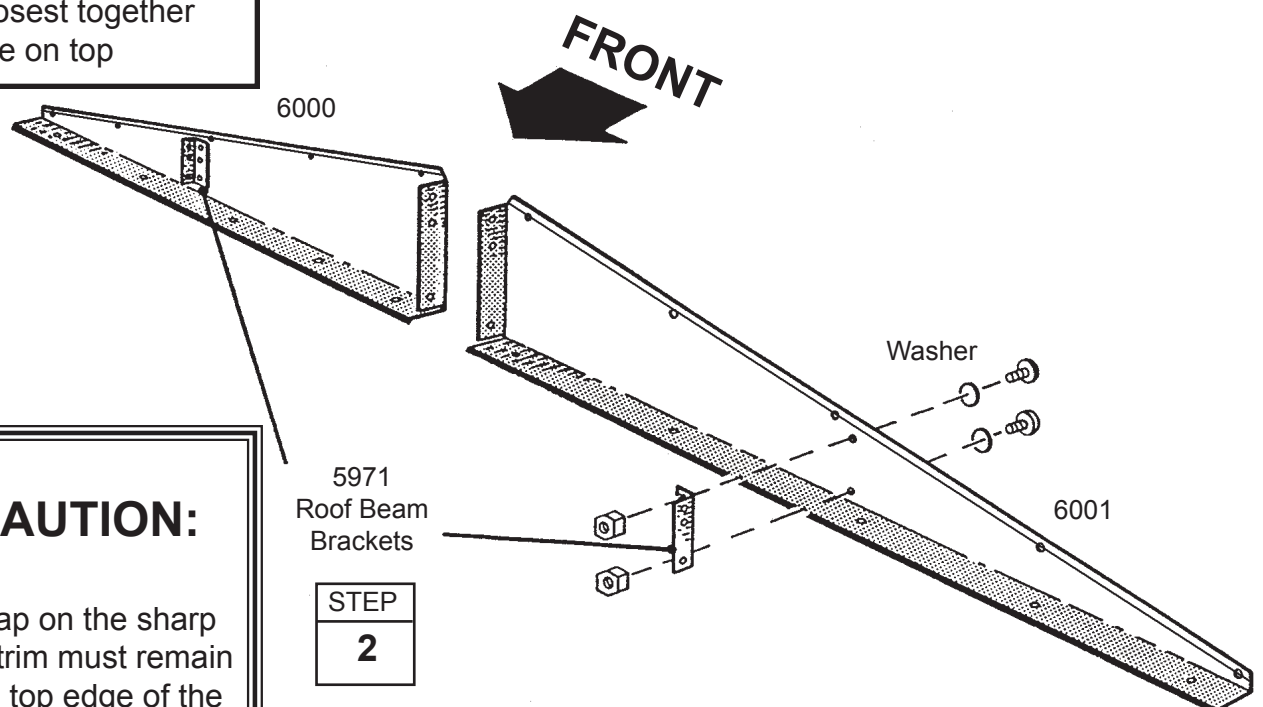
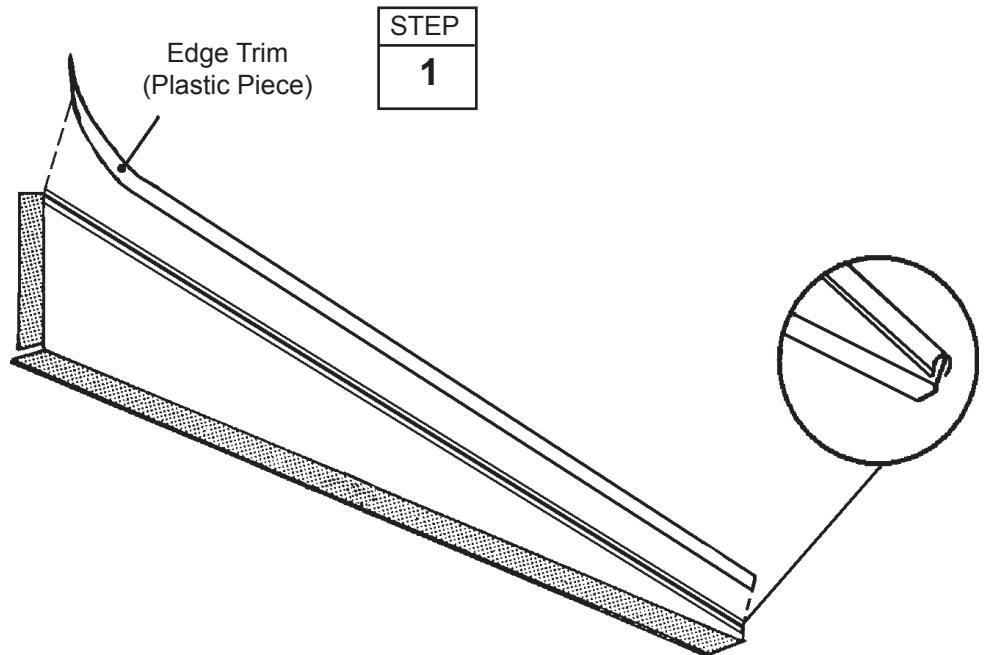



# Step 12

X25 ctr

## Parts Needed For Gables/Braces

Left Gable Assemblies (2)  
Right Gable Assemblies (2)  
6635 Gable Brace (2)



(20)

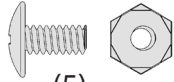

(5)

**1** Lift and fasten a right and left gable, under angle at corner, to the rear wall angle with screws.

Hint: On the rear gable, use a bolt and nut at the overlapping rear wall angle. On the front gable, leave out 2 screws closest to center gable leg.

**2** Join the left and right gables together with a gable brace using a bolt and nut in the bottom hole only.

**3** Repeat Steps 1 & 2 for the door track on the front of building, except for the track supports, fasten as shown.



STEP  
1

Gable

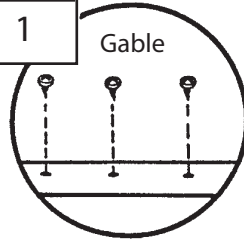

6635 Gable Brace

STEP  
2

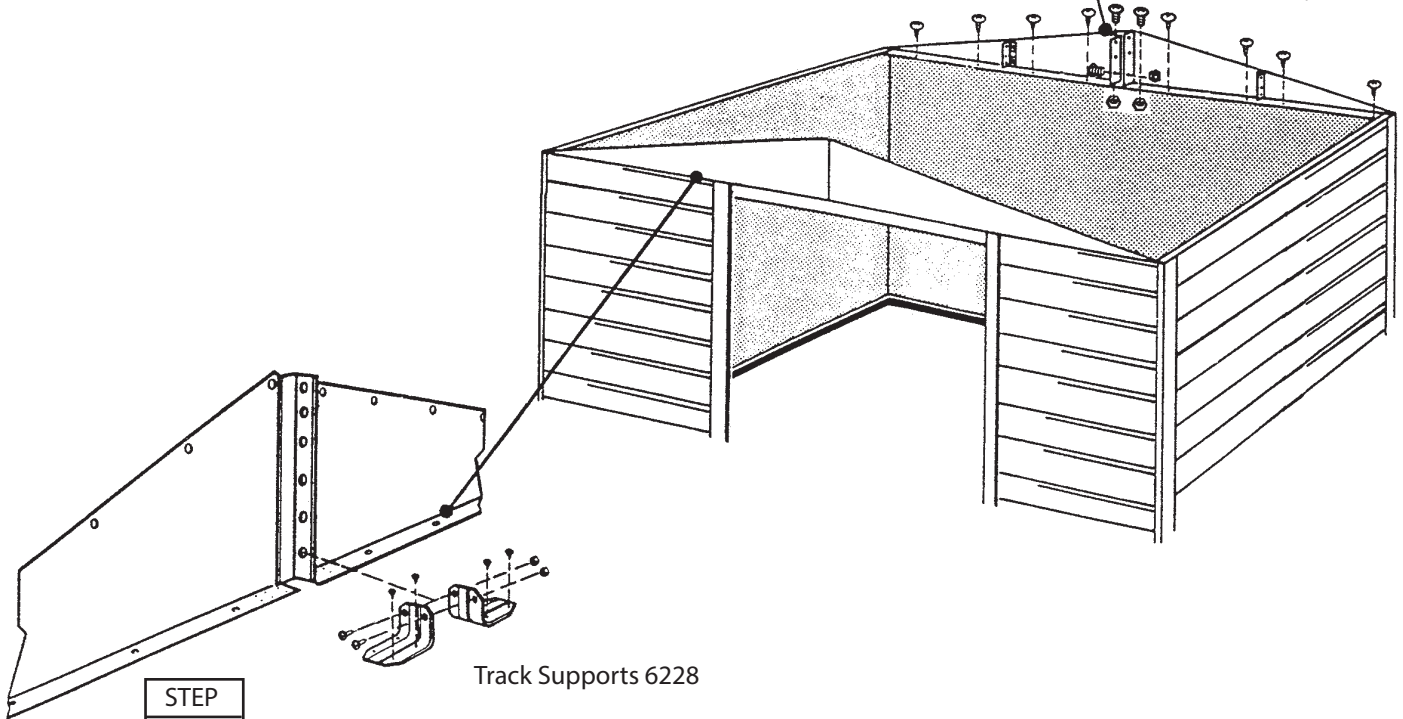
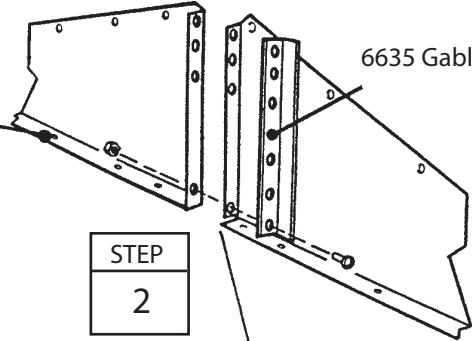

STEP  
3

Track Supports 6228

# Step 13

W26

## Parts Needed For Roof Beams

Main Roof Beam (1)  
8474 Roof Beam (2)

1 Fasten the main roof beam to the gable brace of the front gable.

2 Fasten the other end of the main roof beam to the gable brace of the rear gable.

3 Fasten the remaining roof beams small holes on top as shown using bolts.

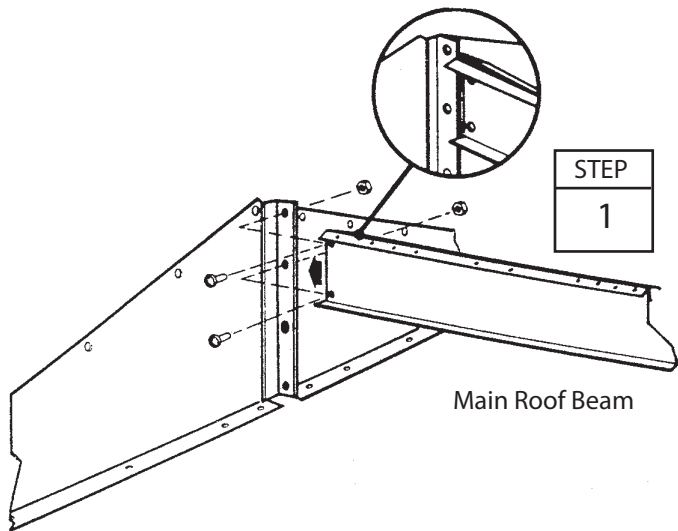
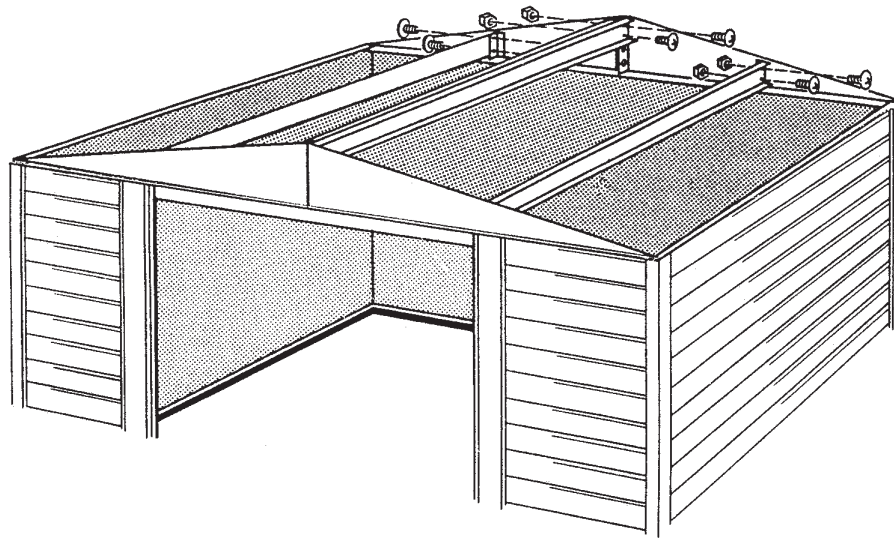
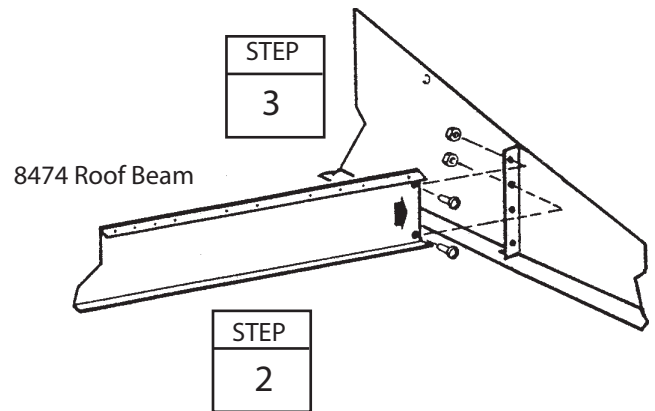

# Step 14

X27et

## Parts Needed For Right Roof Panel

8468 Right Roof Panel (1)

Installing the roof panels is best done with a step ladder. Begin installing roof panels at the back right corner of the building. Each screw and bolt in the roof requires a washer.

### NOTE

Measure the building diagonally again and make adjustments to make sure the building is square. This will make the roof panels fit better, and holes will align.

### NOTE

If a Roof Beef-Up Kit was purchased, assemble prior to attaching the roof panels.

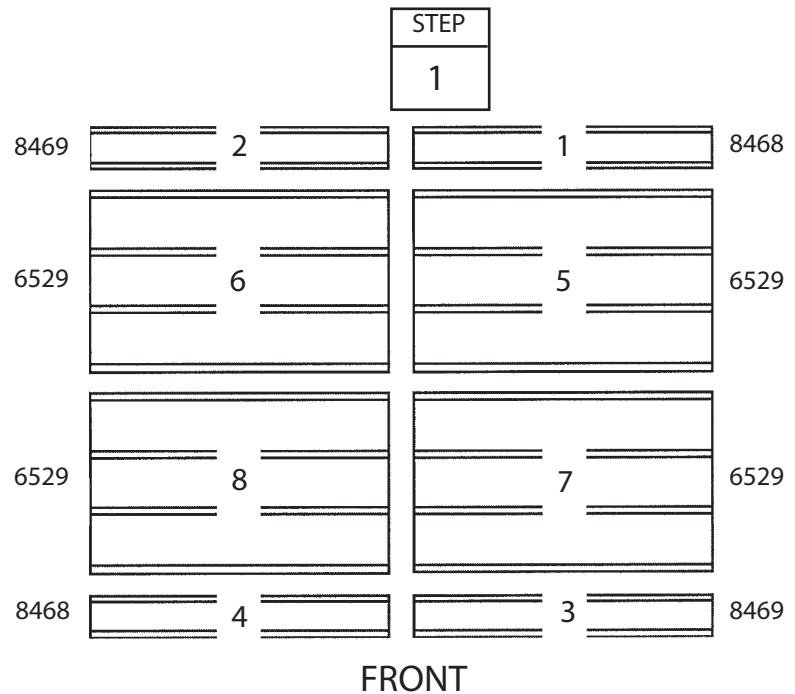

**1** Locate the roof panels by their numbers. Note the sequence and position they are to be installed.

**2** Position a right roof panel at the back right corner and fasten to the top roof beam using a screw.

**3** Remove edge trim from the left gable under the roof panel.

**4** Continue fastening the right roof panel to the gable and lower roof beam using screws, bolts and nuts as shown. Do not fasten the lower end of the panels to the side wall angles at this time.

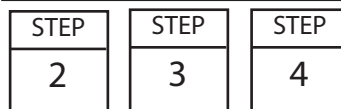

Hint: Follow the fastener sequence shown for proper alignment.

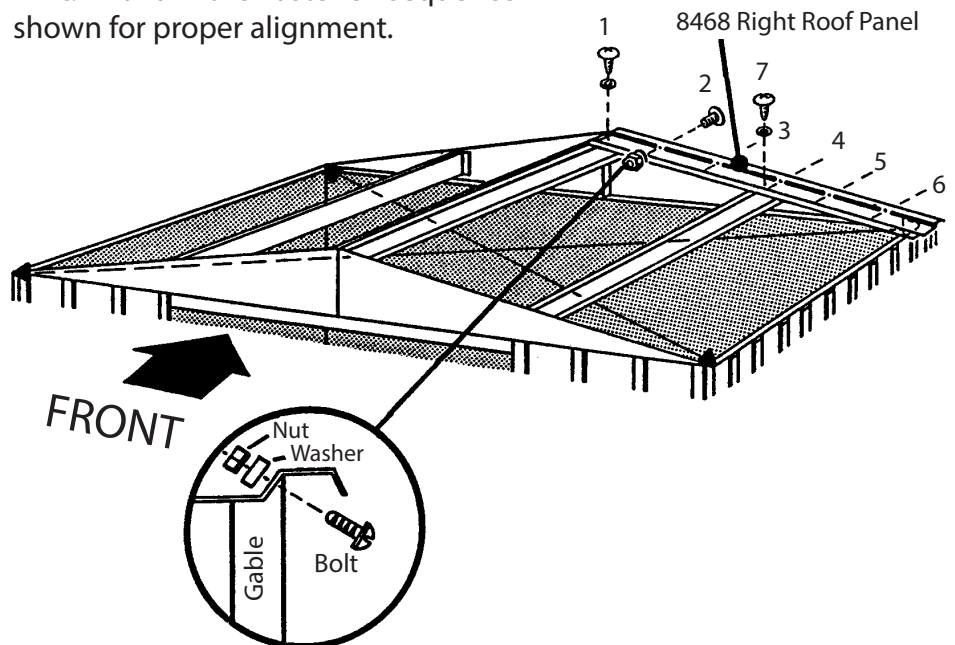

# Step 15

X28

## Parts Needed For Roof Assembly

8468 Right Roof Panel (1)  
8469 Left Roof Panel (2)  
6529 Roof Panel (4)

**1** Install a left roof panel at the left rear and right front corner of the roof. Install a right roof panel at the left front corner of the roof.

**2** Cut 2 short 2" (5,1 cm) strips off the roll of weather stripping tape, and put them aside. Cover the joint at the peak with weather stripping tape. Unroll the tape and press it down over the opening at the ridge as you install each roof panel. Do not cut the tape at this time.

**3** Install 4 roof panels in the sequence and positions shown on previous page. Do not fasten the lower end of the panels to the side wall angles at this time. Continue weather stripping the ridge opening. Fasten roof panel overlaps not used for ridge cap (roof center). Cover the head of bolt with 2" (5,1 cm) piece of weather stripping tape.

STEP  
1

8468 Right  
Roof Panel

8469 Left Roof Panel

Weather Stripping  
Tape Roll

STEP  
2

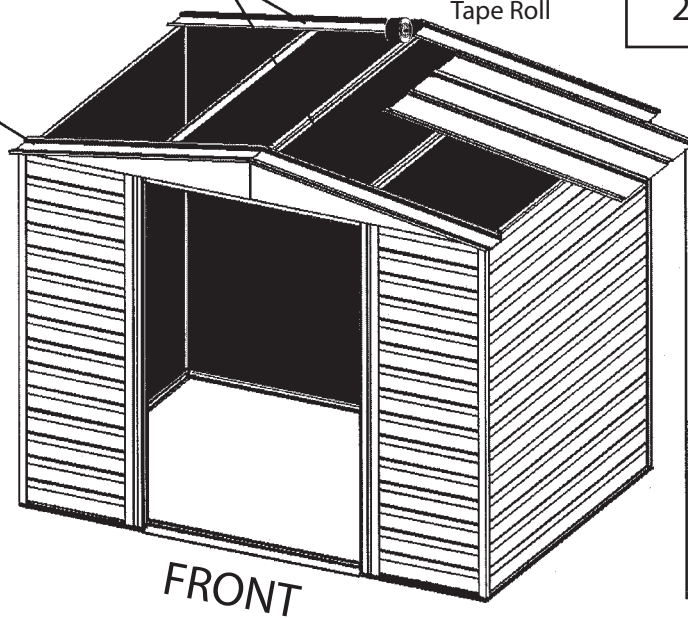

6529 Roof Panel

STEP  
3

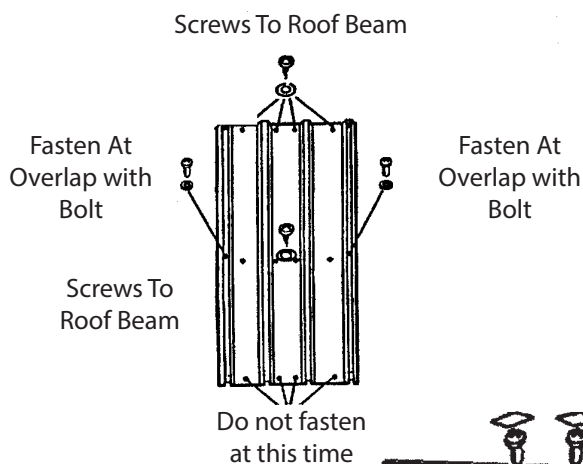

**NOTE**  
Narrow roof panel crimped rib is overlapped by wide rib of adjacent panel where possible.

**NOTE**  
If roof beam holes do not line up with the roof panel holes, shift the building from left to right. If this does not help, your building may not be level. Shim the corners until holes line up.

Cut Weather Stripping and Fold Under.

# Step 16

W29

## Parts Needed For Ridge Cap/Roof Trim

8461 Ridge Cap (1)  
8482 Side Roof Trim (2)

1 Install the ridge cap on the completed roof section using bolts. Do not fasten the ends of the ridge cap until instructed to do so.

2 Fasten the lower end of the panels to the side wall angles using screws and washers.

3 Attach the side roof trim to the lower end of the roof panels on each side of the building using screws at each panel overlap.

4 Using your thumb and index finger, overbend the bottom flange of the side roof trim at the corner inward enough so the right and left roof trim caps fit onto right and left corners.

5 Fasten the roof trim caps to the side trim using a screw.

6 Fasten the roof panel rib, peak cap and ridge cap together using bolts and nuts. Fasten the remaining peak cap in the same manner.

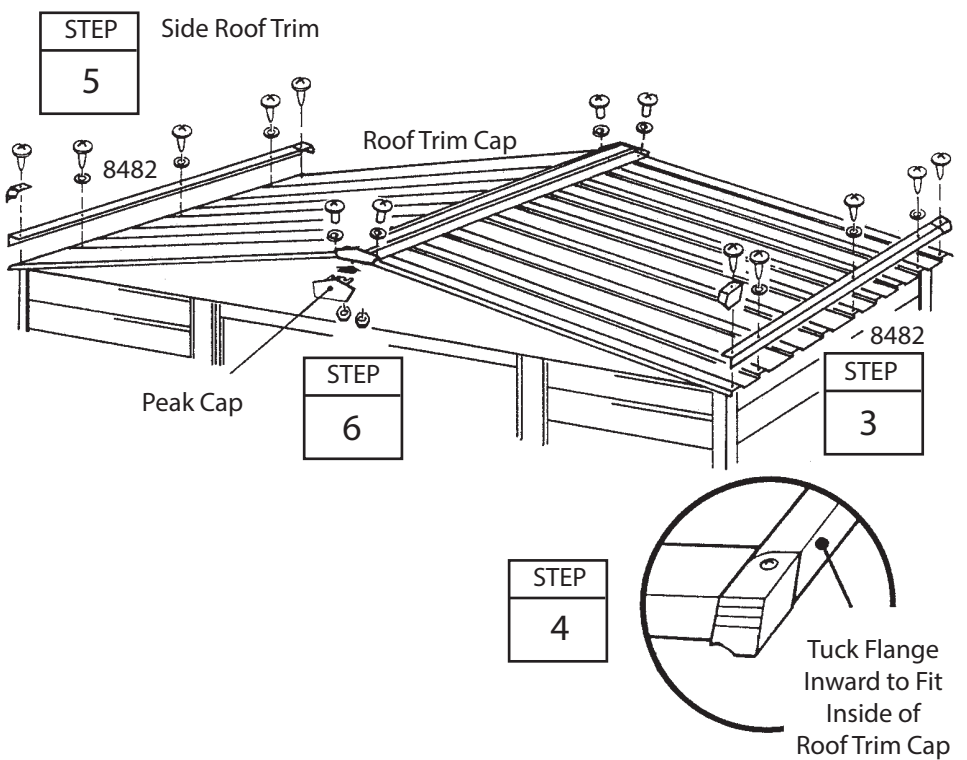
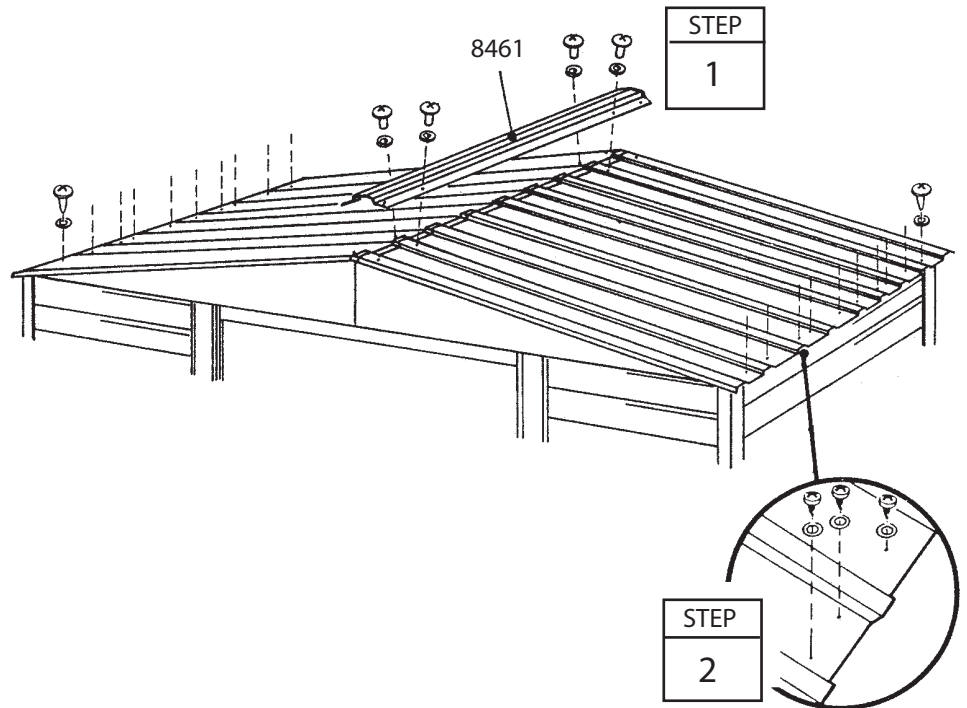

# Step 17

BB30

## Parts Needed For Door Assembly

3719 Door Handle Brace (2)  
10472 Right and Left Doors (2)  
10497 Horizontal Door Brace (4)  
6301 Vertical Door Brace (2)

The steps on this page tell how to assemble the right door. You will perform exactly the same procedures for the left door. Each bolt and screw in the door requires a washer. Proceed as follows:

**1** Attach the door handle brace and handle to the door with 1 bolt as shown. Don't tighten the bolt yet.

**2** Swing the door handle brace up to the hole in the center of the door and insert a screw.

**3** Hold the vertical door brace against the center of the inside surface of the door and turn the screw to hold the vertical door brace and door handle brace in place. Fasten to door above and below center connection using 2 screws.

**4** Insert a second bolt in the door handle and tighten both bolts.

**5** Put a horizontal door brace onto the top edge and bottom edge and fasten with 1 bolt in the center.

**6** Attach the lower door guides and bolts as shown.

**7** Repeat steps 1 through 6 for the left door.

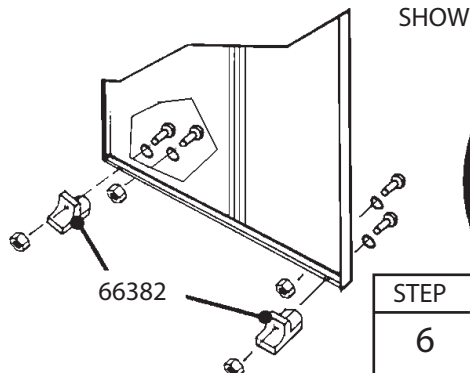
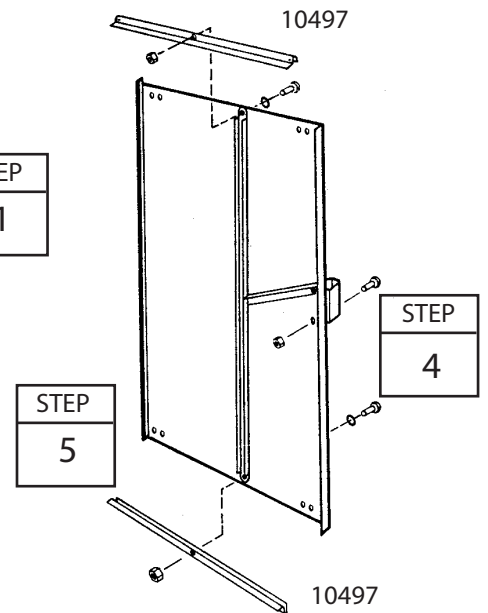
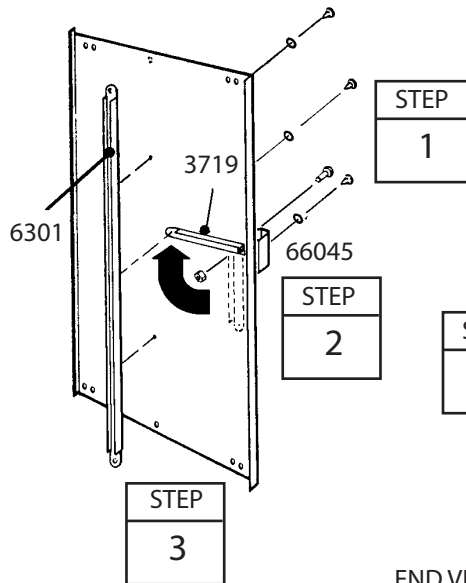
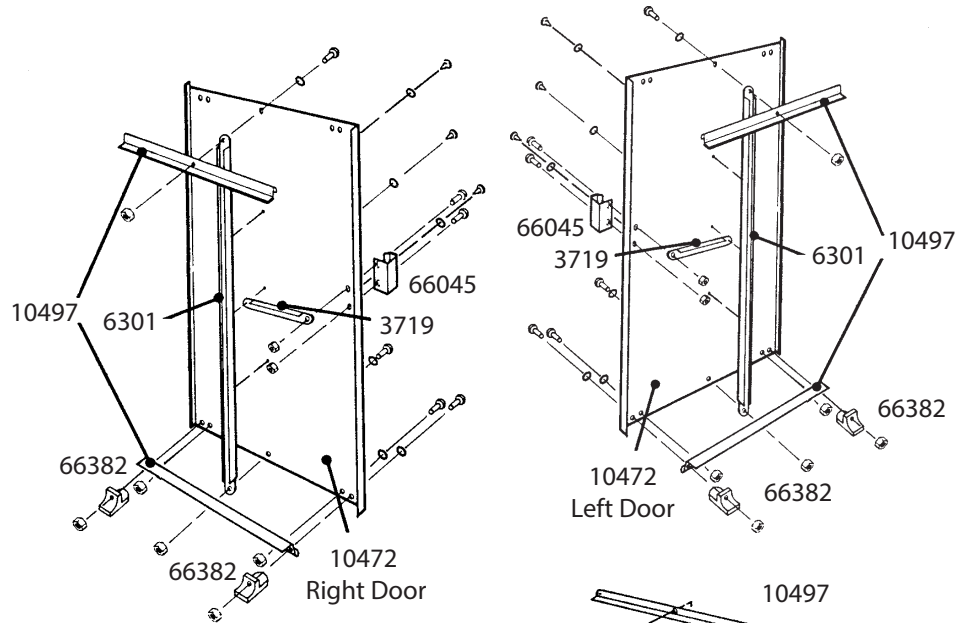

# Step 18

A31

## Parts Needed For Door Installation & Adjustment

Right Door Assembly (1)  
Left Door Assembly (1)

**1** From inside the building, put the bottom of the right door assembly (on your left when you are inside the building) behind door jamb into the front frame track.

**2** Position the top of the door so that the holes in the door line up with the holes in the door slides.

**3** Fasten the door to the door slides using two #10Bx1/2" (13 mm) screws per door slide.

**NOTE**  
The holes in the door slides allow you to adjust the doors. Place the door in the middle holes.

**4** Repeat steps 1 through 3 for the left door.

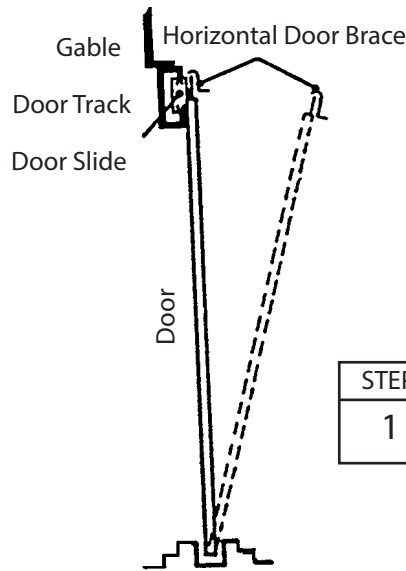

|      |      |
|------|------|
| STEP | STEP |
| 1    | 2    |

Front Floor Frame Assembly

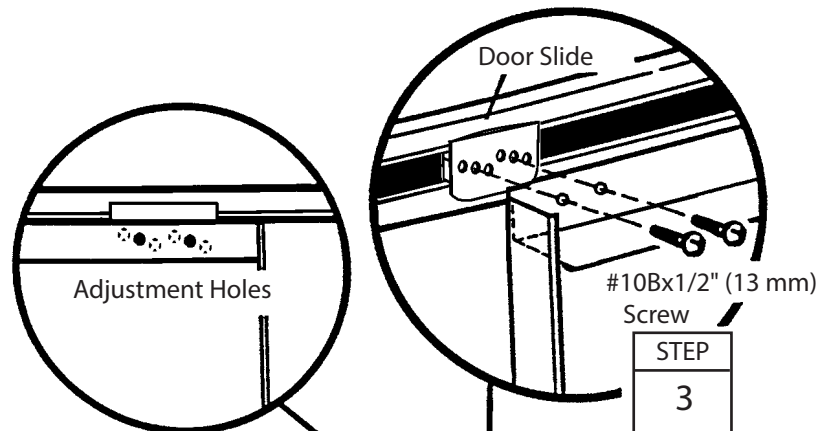

Adjustment Holes Allow Doors to Meet Evenly Along Their Length

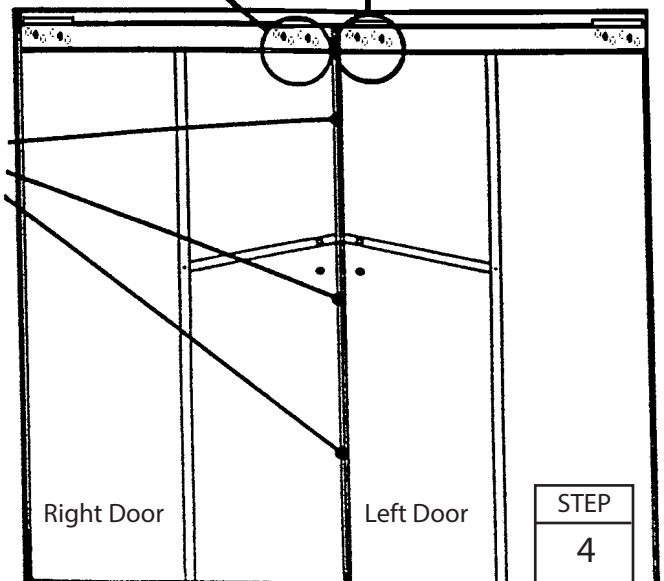

Keep this Owner's Manual and Assembly Instructions for future reference.

**ED106**      **ED106L**      **ED106BS**      **SBVD106** **B**  
**WR106**      **WR106EU**      **VD106** **A**      **VD106EU** **A**  
AJ32      **VDGY106**      **VDGY106EU**      **697.68617** **A**

# Anchoring and Floor Frame

## Anchoring

Anchor your building at this time.

## Floor Frame

If you have purchased a Floor Frame Kit you need to install it at this time.

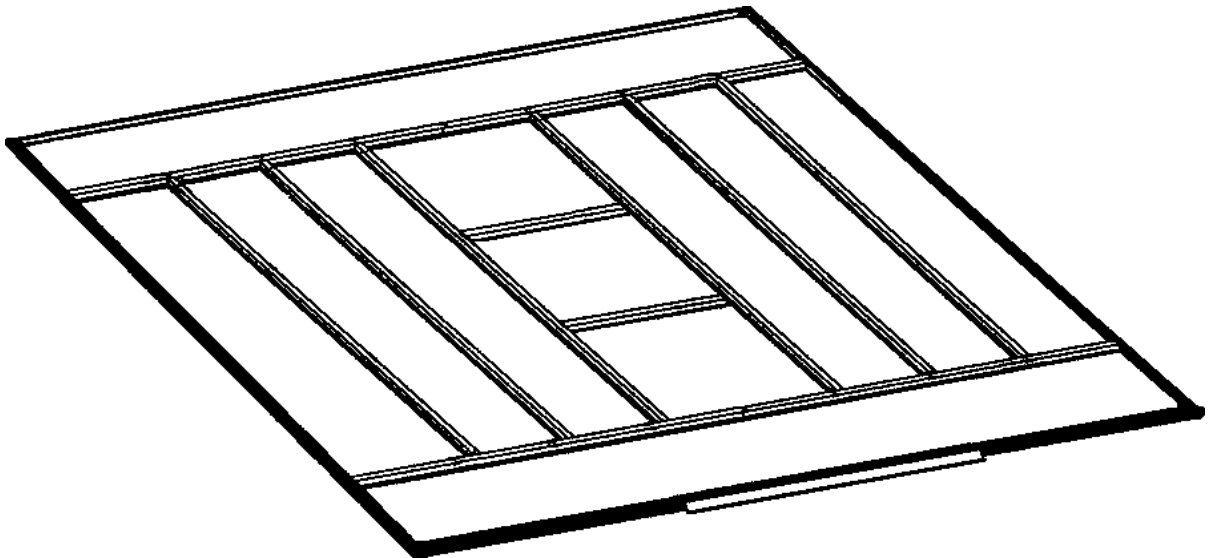

## SOME FACTS ABOUT RUST

Rusting is a natural oxidizing process that occurs when bare metal is exposed to moisture. Problem areas include screw holes, unfinished edges, or where scrapes and nicks occur in the protective coating through normal assembly, handling and use. Identifying these natural rusting problem areas and taking some simple rust protection precautions can help to stop rust from developing, or stop it quickly as soon as it appears.

1. Avoid nicking or scraping the coating surface, inside and out.
2. Use all the washers supplied. In addition to protecting against weather infiltration, the washers protect the metal from being scraped by the screws.
3. Keep roof, base perimeter and door tracks free of debris and leaves which may accumulate and retain moisture. These can do double damage since they give off acid as they decay.
4. Touch up scrapes or nicks and any area of visible rust as soon as possible. Make sure the surface is free of moisture, oils, dirt or grime and then apply an even film of high quality touch-up paint.