

DANCOVER[®]

.com

Manual
for
Greenhouse
2,44x6,01x2,19m

IMPORTANT

Please read these instructions carefully before you start to assemble this greenhouse.
Keep these instructions in a safe place for future reference.

» Customer Service

For assistance with assembly or for replacement parts – please log onto our website or call our service line (number is on the title page).

Additional information can be found at our website: www.palramapplications.com

» Safety Advice

- It is of utmost importance to assemble all of the parts according to the directions. Do not skip any step.
- We strongly recommend using work gloves during panels' sliding.
- Always wear shoes and safety goggles when working with extruded aluminium.
- If using a step ladder or power tools make sure that you follow the manufacturer's safety advice.
- Do not touch overhead power cables with the aluminium profiles.
- Do not attempt to assemble the greenhouse in windy or wet conditions.
- Dispose of all plastic bags. Keep them out of reach of small children.
- Keep children away from the assembly area.
- Do not lean against or push the greenhouse during construction.
- Do not position your greenhouse in an area exposed to excessive winds.
- Do not attempt to assemble this greenhouse if you are tired, have taken drugs or alcohol or if you are prone to dizzy spells.
- Hot items such as recently used grills, blowtorches etc. must not be stored in the greenhouse. Make sure there are no hidden pipes or cables in the ground before inserting the pegs.
- This product is designed to be used mainly as a greenhouse.
- **Note:** You should anchor the greenhouse directly to a solid foundation; Make sure that there are no obstructions between the assembly area and the final position.

» Care & Maintenance

- When your greenhouse needs to be cleaned, use a mild detergent solution and rinse with cold clean water.
- DO NOT use acetone, abrasive cleaners or other special detergents to clean the clear panels.

» Tools & Equipment

- Work gloves
- Phillips head screwdriver
- Adjustable Spanner / Wrench
- Leveler
- Tape measure
- Step ladder
- Scissors
- Electric screwdriver (10mm, 7mm, Phillips)
- Lubricant (Optional)
- T001 - Special tool for Screws 411 and nuts 412

**» Before Assembly**

- Selecting a site:
 - The greenhouse must be positioned and fixed on a flat level surface.
 - Choose a sunny position away from overhanging trees.
- We strongly recommend this greenhouse to be secured directly to a solid concrete foundation.
- This is a multi-part assembly best achieved by two people. Allow at least half a day for the assembly process.
- Take all components & parts out of the packages. Sort the parts and check against the content parts list.
Parts should be laid out close at hand. Keep all small parts (screws etc.) in a bowl so they do not get lost.
- Please note multi-sided profiles are used in this greenhouse. As a result some holes in the profiles are not used during assembly.
- Please review entire instructions before starting. Carry out the assembly steps in exact order.
- The drawings in this manual are designed for 8' x 8' greenhouse + 4' Extension Kit. Please note that content list refers only for 8x8 greenhouse.

Note: all the extension module steps are marked with a dashed outline, should be performed during the greenhouse assembly process.

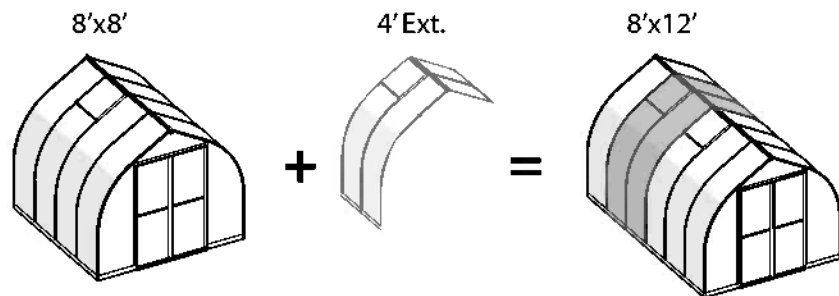

Model	Base Length	No. of Packages
Bella (8' x 8')	244 cm / 96.1"	1
Bella + 4' Ext. (8' x 12')	363 cm / 142.9"	2
Bella + 4' Ext. x 2 (8' x 16')	482 cm / 189.8"	3
Bella + 4' Ext. x 3 (8' x 20')	601 cm / 236.6"	4

» During Assembly

- Make sure the base is square by measuring the diagonals and level by using a spirit level.
- Peel the film covering the panel. Make sure you install it with the UV protected side out.
- You may use Silicon lubricant spray in order to help you slide the panels into the profiles.
- Do not spray the Polycarbonate panels.
- Use a rubber mallet if necessary.
- All panels with the stamped words THIS SIDE OUT must be facing out to create full UV protection. Remove plastic sticker as panels are locked in place.

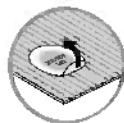

During assembly you will encounter the information icon, please refer to the relevant assembly step for additional comments and assistance.



This icon indicates that the installer should be inside the product.



This icon indicates that the installer should be outside the product.

Step 3: Refers only for the extension kit! The extension kit contains a base connector, either part #8447 or #7601

Step 7: Roof window can be located only on one of the two central roof panels.

If you assemble the greenhouse with an extension module, the roof windows must be placed on panels only as specified in the manual.

*** Note:** The selected placing will affect the next assembly steps.

Step 8: Please make sure you place profile and screws according to the window location (**Step 7**)

Step 41: In case the window is not closed properly, please go to **Step 40b**, release the screws, adjust the profile and tighten the screw.

Step 44: Peel the film covering the panel. Make sure you install it with the UV protected side out.

Step 53: Choose the appropriate anchoring according to the existing base. Screws and masonry anchors are not supplied.



Important Recommendations

- Firmly connect the greenhouse to a level surface immediately after completion of the assembly.
- Anchoring this product to the ground is essential to its stability and rigidity. It is required to complete this stage in order for your warranty to be valid.
- Tighten all screws once assembly is completed.

- Screws 411 and nuts 466 are used throughout the assembly process.
- Screws 411 are to be assembled from the outside and nuts 466 from the inside of the greenhouse.
- If not specified otherwise, do not fasten screws and nuts (411 & 466) for more than 2-3 turns. Do not tighten them until completion of the panels' assembly. These 2 icons indicate if screw's tightening is required or not.
- However, in some steps, temporary tightening of a few screws may be needed to prevent a profile from sliding out.



IMPORTANT !

Veuillez lire attentivement ces instructions avant de commencer à monter votre serre. Conservez ces instructions en lieu sûr pour toute consultation ultérieure.

» Service clientèle

Pour toute assistance concernant le montage de la serre ou ses pièces de rechange – veuillez consulter notre site Internet ou appeler notre service technique (dont le numéro de téléphone figure sur la couverture de la brochure). Pour en savoir plus,

n'hésitez pas à visiter notre site Internet : www.palamapplications.com

» Consignes de sécurité

- Très important ! Veuillez suivre scrupuleusement les instructions de cette brochure et réaliser les étapes dans l'ordre énoncé.
- Nous recommandons vivement le port de gants de protection pendant le montage.
- Portez toujours des chaussures de travail et des lunettes de protection lorsque vous travaillez des pièces en aluminium extrudé.
- Lors de l'utilisation d'une échelle ou d'outils électriques, assurez-vous de bien suivre les consignes de sécurité du fabricant.
- Veillez à ne pas toucher de câbles aériens avec les profilés en aluminium.
- N'essayez pas de monter la serre s'il y a du vent ou s'il fait humide.
- Jetez tous les sacs en plastique en appliquant les règles de sécurité et maintenez-les hors de portée des jeunes enfants.
- Eloignez les enfants de la zone d'assemblage.
- Ne vous appuyez pas contre la serre et ne la poussez pas pendant le montage.
- Ne positionnez pas la serre dans un endroit trop exposé au vent.
- N'essayez pas de monter la serre si vous êtes fatigué, si vous êtes sous l'effet de drogues, de médicaments ou d'alcool ou encore si vous êtes sujet aux vertiges.
- Les objets chauds tels qu'un barbecue, un chalumeau ou autre article ayant été récemment utilisés, ne doivent pas être rangés dans la serre.
- Avant de planter les piquets, assurez-vous qu'aucun tuyau ni câble n'est enterré à l'endroit sélectionné pour l'installation.
- Ce produit a été conçu pour être principalement utilisé comme serre.
- **Remarque:** Vous devez ancrer la serre de jardin directement à une fondation solide ; assurez-vous qu'il n'y a pas d'obstacles entre la zone de montage et la position finale.

» Entretien & Maintenance

- Pour nettoyer votre serre, utilisez une solution détergente douce et rincez à l'eau claire et froide.
- NE PAS utiliser d'acétone ni de produits nettoyants ou autres détergents spéciaux pour nettoyer les panneaux clairs.

» Outils & Equipement (non fournis)

- Gants de travail
- Tournevis cruciforme
- Clé à molette / Clé
- Niveleur
- Ruban à mesurer
- Escabeau
- Ciseaux
- Tournevis électrique (10 mm, 7 mm, Cruciforme)
- Lubrifiant (Facultatif)
- T001 - Outil spécial pour vis 411 et écrous 412



» Avant le montage

- Choisir un endroit :
 - La serre doit être positionnée et fixée sur une surface plane et horizontale.
 - Choisissez un endroit ensoleillé loin des arbres en saillie.
- Nous vous recommandons fortement de sécuriser cette serre directement à une fondation en béton solide. Utilisez les trous pré-perçés dans la base métallique au moment de le faire.
- Il s'agit d'un assemblage multi parties qu'il vaut mieux réaliser à deux. Comptez au moins une demi journée pour le processus de montage.
- Retirez tous les composants des paquets. Triez les éléments et vérifiez la liste. Les éléments doivent se trouver à portée de main.
 - Gardez tous les petits éléments (vis etc.) dans un bol pour ne pas les perdre.
- Veuillez noter que des coupes multi faces sont utilisées dans cette serre. C'est pourquoi certains trous dans les coupes ne sont pas utilisés pendant le montage.
- Veuillez vérifier toutes les instructions avant de commencer. Procédez aux étapes de montage dans l'ordre exact.
- Les schémas de ce manuel sont conçus pour un serre de jardin 8'x 8' + Kit d'extension 4'. Veuillez noter que la liste de contenu se réfère uniquement aux serres de jardin 8'x8'.

Remarque : Toutes les étapes de module d'extension sont marquées avec un contour en pointillés dans l'intégralité du processus d'assemblage du serre de jardin.

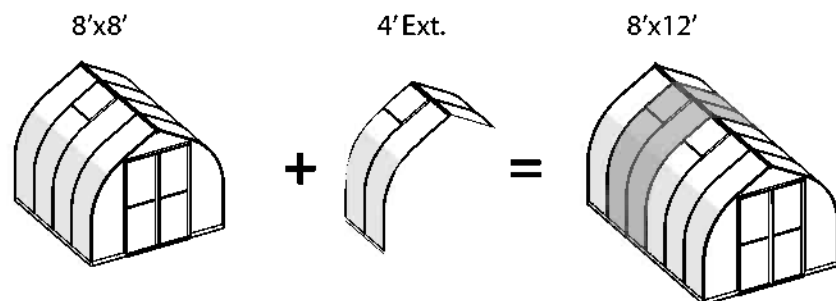

Modèle	Longueur de la base	Nombre de packs
Bella (8' x 8')	244 cm / 96.1"	1
Bella + 4' Ext. (8' x 12')	363 cm / 142.9"	2
Bella + 4' Ext. x 2 (8' x 16')	482 cm / 189.8"	3
Bella + 4' Ext. x 3 (8' x 20')	601 cm / 236.6"	4

» Durant l'assemblage

- Assurez-vous que la base soit bien carrée en mesurant les diagonales et le nivelage à l'aide d'un niveau à bulle.
- Assurez-vous que cette face est bien tournée vers le haut lors de l'installation, car c'est la seule à être enduite d'un vernis anti-UVs.
- Vous pouvez utiliser un spray de silicone lubrifiant afin de vous aider à glisser les panneaux dans les profils.
- Ne pulvérisez pas les panneaux en polycarbonate.
- Utilisez un maillet en caoutchouc si nécessaire.
- Tous les panneaux estampillés "THIS SIDE OUT" doivent être orientés vers l'extérieur pour assurer une protection UV intégrale. Retirez les stickers en plastique alors que les panneaux sont verrouillés en place.

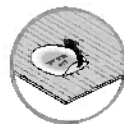

Pendant le montage, vous verrez l'icône d'information, veuillez-vous référer à la phase de montage correspondante pendant des commentaires et une assistance supplémentaires.



Cette icône indique que l'installateur doit être à l'intérieur du produit



Cette icône indique que l'installateur doit être en dehors du produit.

Étape 3 : Concerne seulement le kit d'extension ! Le kit d'extension contient un connecteur de base, soit la pièce n° 8447 ou la pièce n° 7601.

Étape 7 : La fenêtre du toit peut être placée uniquement sur l'un des deux panneaux centraux du toit. Si vous assemblez le serre de jardin avec un module d'extension, les fenêtres de toit doivent être placées sur des panneaux seulement comme spécifié dans le manuel.

*** Remarque :** L'emplacement sélectionné aura des conséquences sur les prochaines étapes de montage.

Étape 8 : Veillez à bien placer le profil et les vis selon l'emplacement de la fenêtre (**étape 7**).

Étape 41 : Au cas où la fenêtre ne ferme pas correctement, référez-vous à l'**étape 40b**, veuillez relâcher les vis, ajustez la coupe et serrez les vis.

Étapes 44 : Assurez-vous que cette face est bien tournée vers le haut lors de l'installation, car c'est la seule à être enduite d'un vernis anti-UVs.

Étape 53 : Fixer la serre peut également être effectué en perçant les coupes de base et en la fixant au sol en utilisant des vis de terre (vis non fournies).



Recommandations importantes

- Connectez le serre de jardin fermement à une surface nivelée après l'achèvement de l'assemblage.
- Cette étape d'ancrage du produit au sol est essentielle à sa stabilité et à sa rigidité, elle est de plus nécessaire pour assurer la validité de votre garantie.
- Serrez toutes les vis une fois l'assemblage terminé.

Les vis 411 et écrous 466 servent tout au long de la procédure.

- Les vis 411 se placent à l'extérieur et les écrous 466 à l'intérieur de la serre.
- Ne serrez les vis et écrous (411 & 466) que de 2 à 3 tours, pas plus. Ne les serrez pas tant que l'assemblage n'est pas complètement terminé, sauf indication contraire.
- Cependant, la réalisation de certaines étapes peut nécessiter le serrage provisoire de quelques vis pour empêcher un profilé de tomber en attendant qu'il soit entièrement intégré à l'ensemble de la structure dans les étapes suivantes.

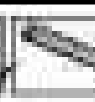
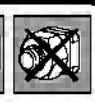
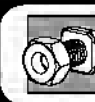

WICHTIG

Bitte lesen Sie diese Anweisungen sorgfältig durch, bevor Sie mit dem Aufbau des Gewächshauses beginnen.

Heben Sie diese Anweisungen an einem sicheren Ort auf, um später auf sie zurückgreifen zu können.

» Kundendienst

Für Hilfe bei dem Aufbau oder für Ersatzteile – können Sie sich entweder auf unserer Webseite einloggen oder unseren Kundendienst anrufen (die Nummer steht auf der Titelseite).
www.palamapplications.com

» Sicherheitshinweise

- Es ist von grösster Wichtigkeit, alle Teile genau gemäss den Anweisungen zusammenzubauen. Lassen Sie keinen Schritt aus.
- Wir empfehlen wärmstens, während des Aufbaus Arbeitshandschuhe zu tragen.
- Tragen Sie immer Schuhe und eine Schutzbrille, wenn Sie mit stranggepresstem Aluminium arbeiten.
- Wenn Sie eine Stufenleiter oder Elektrowerkzeuge benutzen, achten Sie darauf, die Sicherheitshinweise des Herstellers zu befolgen.
- Berühren Sie mit den Aluminiumprofilen keine Oberleitungen.
- Versuchen Sie nicht, das Gewächshaus bei windigem oder regnerischem Wetter zusammenzubauen.
- Entsorgen Sie alle Plastiktüten sicher und bewahren sie ausserhalb der Reichweite von kleinen Kindern auf.
- Halten Sie Kinder vom Aufbaubereich fern.
- Während des Aufbaus sollten Sie sich nicht gegen das Gewächshaus lehnen oder es drücken.
- Bauen Sie Ihr Gewächshaus nicht an Orten mit hoher Windbelastung auf.
- Versuchen Sie nicht, dieses Gewächshaus aufzubauen wenn Sie müde sind, unter dem Einfluss von Drogen oder Alkohol stehen oder zu Schwindelanfällen neigen.
- Heisse Geräte wie kürzlich benutzte Grills, Schneidbrenner usw. dürfen nicht im Gewächshaus gelagert werden. Vergewissern Sie sich vor Einsetzen der Pflöcke, dass sich keine versteckten Rohre oder Kabel im Boden befinden.
- Dieses Produkt wurde gestaltet, um hauptsächlich als Gewächshaus benutzt zu werden.
- **Hinweis:** Sie sollten das Gewächshaus direkt in einem stabilen Fundament verankern. Sorgen Sie dafür, dass sich zwischen dem Montage- und dem Aufstellort des Gewächshauses keine Hindernisse befinden.

» Pflege & Wartung

- Wenn Ihr Gewächshaus gereinigt werden muss, verwenden Sie ein mildes Reinigungsmittel und spülen Sie mit kaltem, sauberem Wasser nach.
- Verwenden Sie zur Reinigung der durchsichtigen Elemente KEIN Aceton und auch keine anderen scheuernden Reinigungsmittel oder andere Spezialreiniger.

» Werkzeuge & Ausrüstung

- Arbeitshandschuhe
- Kreuzschlitz-Schraubendreher
- Rollgabelschlüssel / Schraubenschlüssel
- Wasserwaage
- Maßband
- Stehleiter
- Schere
- Akku-Schraubendreher (10 mm, 7 mm, Kreuzschlitz)
- Schmiermittel (optional)
- T001 – Spezialwerkzeug für Schrauben 411 und Muttern 412



» Vor dem Zusammenbau

- Einen Aufstellungsort auswählen:
 - Das Gewächshaus muss auf einem flachen Untergrund aufgestellt und befestigt werden.
 - Wählen Sie eine sonnige Position abseits von überhängenden Bäumen.
- Wir empfehlen dringend, dieses Gewächshaus direkt auf einem soliden Betonfundament zu befestigen. Verwenden Sie dabei die vorgebohrten Löcher in der Metallbasis.
- Dieser mehrteilige Bausatz sollte am besten von zwei Personen aufgebaut werden. Nehmen Sie sich für den Zusammenbau mindestens einen halben Tag Zeit.
- Entpacken Sie alle Bauteile. Sortieren Sie die Teile und vergleichen Sie sie mit der Stückliste. Die Teile sollten griffbereit ausgelegt werden.
 - Bewahren Sie alle kleinen Teile (Schrauben usw.) in einer Schüssel, um zu verhindern, dass sie verlorengehen.
- Beachten Sie bitte, dass bei diesem Gewächshaus mehrseitige Profile verwendet werden. Während des Zusammenbaus werden daher einige Löcher in den Profilen nicht verwendet.
- Lesen Sie bitte vor dem Zusammenbau die gesamte Anleitung durch. Befolgen Sie beim Zusammenbau die genaue Reihenfolge.
- Die Zeichnungen in diesem Handbuch sind für 8' x 8' Gewächshaus + 4 'Extension Kit entwickelt. Bitte beachten Sie, dass der Inhalt Liste bezieht sich nur für 8x8-Gewächshaus.
 - Hinweis:** alle Erweiterungsmodul Schritte sind mit gestrichelter Umriss markiert sein sollte im Gewächsmontageprozess durchgeführt wird.

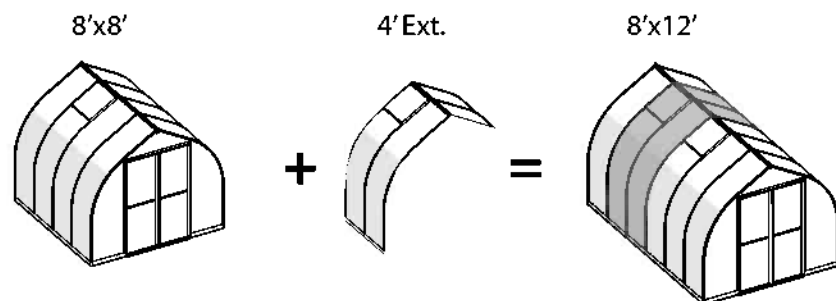

Modell	Basislänge	Packungsanzahl
Bella (8' x 8')	244 cm / 96.1"	1
Bella + 4' Ext. (8' x 12')	363 cm / 142.9"	2
Bella + 4' Ext. x 2 (8' x 16')	482 cm / 189.8"	3
Bella + 4' Ext. x 3 (8' x 20')	601 cm / 236.6"	4

» Während der Montage

- Vergewissern Sie sich, dass die Basis sowohl quadratisch als auch waagrecht ist, indem Sie die Diagonalen messen und die Basis mit einer Wasserwaage prüfen.
- Diese Seite soll nach oben zeigend angebracht werden. Sie ist die Einzige mit einer UV-Schutz Lackierung.
- Um das Einführen der einzelnen Platten in die Profile zu vereinfachen, können Sie Silikon-Gleitspray verwenden.
- Besprühen Sie nicht die Polycarbonat-Platten.
- Nehmen Sie – falls nötig – einen Gummihammer zur Hilfe.
- Alle mit den Worten THIS SIDE OUT versehenen Platten müssen nach außen zeigen, damit der volle UV-Schutz garantiert werden kann.

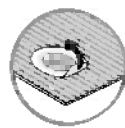

 Beim Aufbau wird Ihnen das Informationssymbol begegnen. Für zusätzliche Kommentare und Unterstützung beziehen Sie sich bitte auf die entsprechende Aufbaustufe.



Dieses Symbol zeigt an, dass sich die installierende Person sich im Inneren des Produktes befinden sollte.



Dieses Symbol zeigt an, dass die installierende Person sich außerhalb des Produktes befinden sollte.

Schritt 3: Betrifft nur den Verlängerungsbausatz! Im Verlängerungsbausatz befindet sich ein Verbindungsstück mit Artikel # **8447** oder # **7601**

Schritt 7: Dachfenster kann nur auf einem der beiden mittleren Dachpaneele angeordnet sein.

Wenn Sie das Gewächshaus mit einem Erweiterungsmodul montieren, müssen die Dachfenster auf Panels nur, wie im Handbuch angegeben platziert werden.

* **Hinweis:** Die zur Befestigung gewählte Platte beeinflusst die folgenden Montageschritte.

Schritt 8: Bitte stellen Sie sicher, dass Sie die Profile und die Schrauben entsprechend der Position des Fensters legen. (**Schritt 7**)

Schritt 41: Falls das Fenster nicht richtig schließen sollte, folgen Sie **Schritt 40b**, lösen Sie bitte die Schrauben, stellen Sie die Profile erneut ein und ziehen Sie die Schrauben zusammen.

Schritt 44: Diese Seite soll nach oben zeigend angebracht werden. Sie ist die Einzige mit einer UV-Schutz Lackierung.

Schritt 53: Das Gewächshaus kann auch verankert werden, indem man die Sockelprofile anbohrt und am Boden mit Bodenschrauben und Krampen festmacht (Schrauben und Spikes werden nicht mitgeliefert).



Wichtige Hinweise

- Befestigen Sie das Gewächshaus sofort nach Fertigstellung der Montage auf einem geraden Untergrund.
- Die Verankerung dieses Produkts im Untergrund ist wesentlich für seine Stabilität und Festigkeit. Sie ist unablässlich, um diesen Arbeitsschritt zu beenden, damit Ihre Garantie gültig bleibt.
- Ziehen Sie alle Schrauben fest, sobald die Montage beendet ist.

- In manchen Fällen kann es jedoch nötig sein, einige Schrauben vorübergehend festzuziehen, um das Umfallen eines Profils zu vermeiden. (466)
- Ziehen Sie die Schrauben und Muttern (411 und 466) nicht mit mehr als 2 – 3 Umdrehungen fest. Ziehen Sie sie erst nach Beendigung der Verglasung weiter fest, falls dies nicht ausdrücklich anders festgelegt ist.
- Bei einigen Schritten müssen allerdings eventuell ein paar Schrauben vorübergehend angezogen werden, um zu vermeiden dass ein Profil fällt.

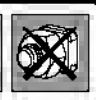
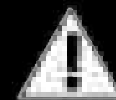

466



411



IMPORTANTE

Por favor, lea estas instrucciones cuidadosamente antes de empezar a montar este invernadero.

Mantenga estas instrucciones en un lugar seguro para referencia futura.

» Servicio de Ayuda al Cliente

Para obtener ayuda con el montaje o para las piezas de recambio - por favor entre a nuestro sitio web o llame a nuestra línea de servicio (el número está en la página de título).

Información adicional se puede encontrar en nuestro sitio web:
www.palramapplications.com

» Consejo de Seguridad

- Es de suma importancia montar todas las partes de acuerdo con las instrucciones. No se salte ningún paso.
- Recomendamos firmemente el uso de guantes de trabajo durante el montaje.
- Use siempre zapatos y gafas de seguridad al trabajar con aluminio extruido.
- Al usar una escalera plegable o herramientas eléctricas asegúrese de que sigue las instrucciones de seguridad de los fabricantes.
- No toque los cables eléctricos aéreos con los perfiles de aluminio.
- No intente montar el invernadero en días de viento o días con humedad.
- Disponga todas las bolsas plásticas en lugar seguro - guárdelas fuera del alcance de niños.
- Mantenga a los niños fuera del área de montaje.
- No se apoye ni empuje el invernadero durante la construcción.
- No coloque su invernadero en un área expuesta al viento excesivo.
- No intente montar este invernadero si usted está cansado, ha tomado drogas o alcohol o si usted es propenso a ataques de mareo.
- Artículos calientes recientemente usados tales como parrillas, sopletes etc. no deben ser almacenados en el invernadero. Asegúrese de que no haya ninguna tubería o cables ocultos en la tierra antes de insertar las clavijas.
- Este producto fue diseñado para ser utilizado principalmente como un invernadero.
- **Nota:** debe anclar el invernadero directamente a una base sólida; Asegúrese de que no hay obstáculos entre el área de montaje y la posición final.

» Cuidados & Mantenimiento

- Cuando su invernadero necesite limpieza, utilice una solución detergente suave y enjuague con agua limpia fría.
- NO UTILICE acetona, limpiadores abrasivos u otros detergentes especiales para limpiar los paneles. Se recomienda comprobar periódicamente que los paneles del techo>tapones (parte de plástico 329 y perfil 981) están colocados en el lugar.

» Herramientas & Equipos

- Guantes de trabajo
- Destornillador Phillips
- Llave ajustable/Llave
- Nivelador
- Cinta métrica
- Escalera
- Tijeras
- Destornillador eléctrico (de 10 mm, 7 mm, Phillips)
- Lubricante (opcional)
- T001 - Herramienta especial para tornillos 411 y tuercas 412



» Antes del Montaje

- ☑ Seleccionar un lugar:
 - El invernadero debe colocarse y fijarse en una superficie plana y nivelada.
 - escoja una ubicación soleada y apartada de árboles que la cubran.
- ☑ Recomendamos encarecidamente que el invernadero se fije directamente sobre cimientos de cemento sólido. Para hacer esto, utilice los agujeros previamente taladrados en la base de metal.
- ☑ Este montaje consta de varias partes y sería óptimo que lo realizaran dos personas. El proceso de montaje llevará alrededor de medio día.
- ☑ Extraiga todas las piezas de componentes de sus embalajes. Ordene las piezas y compruebe que están todas usando la lista de contenidos. Las piezas deberían colocarse cerca y tenerlas a mano. Ponga las piezas pequeñas (p. ej. tornillos) en un bol para no perderlas.
- ☑ Por favor, tenga en cuenta que este invernadero incluye perfiles con múltiples superficies. Como resultado, algunos de los agujeros de los perfiles no se utilizan durante el montaje.
- ☑ Por favor, revise todas las instrucciones antes de empezar. Siga los pasos del montaje en el orden exacto.
- ☑ Los dibujos de este manual están diseñados para invernaderos de 8' x 8' + Kit de extensión de 4'. Tenga en cuenta que la lista de contenido se refiere sólo a invernaderos 8x8.
- ☑ **Nota:** todos los pasos del módulo de extensión están marcados con un contorno de trazos, y deben ser realizados durante el proceso de montaje del invernadero.

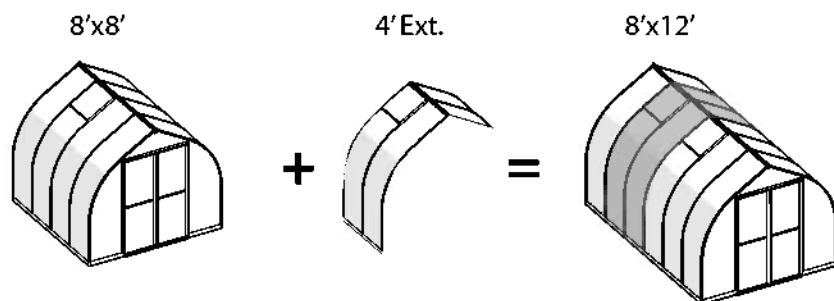

Modelo	Longitud base	Número de paquetes
Bella (8' x 8')	244 cm / 96.1"	1
Bella + 4' Ext. (8' x 12')	363 cm / 142.9"	2
Bella + 4' Ext. x 2 (8' x 16')	482 cm / 189.8"	3
Bella + 4' Ext. x 3 (8' x 20')	601 cm / 236.6"	4

» Durante el montaje

- Asegúrese de que la base es cuadrada, midiendo las diagonales y el nivel mediante el uso de un nivel de burbuja.
- Pele la película que cubre el panel. Asegúrese de instalarla con el lado con protección UV hacia afuera.
- Es posible utilizar un aerosol lubricante de silicona con el fin de ayudar a deslizar los paneles en los perfiles.
- No pulverice los paneles de policarbonato.
- Utilice un martillo de goma si es necesario.
- Todos los paneles con las palabras estampadas THIS SIDE OUT deben estar mirando hacia afuera para crear una protección UV completa. Quite la etiqueta de plástico a medida que bloquee los paneles en su lugar.

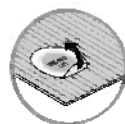

 Cuando vea el icono de información, por favor, acuda al paso de montaje correspondiente para ver comentarios y asistencia adicional.



Este ícono indica que el instalador debe estar dentro del producto.



Este ícono indica que el instalador debe estar fuera del producto.

Paso 3: únicamente se refiere al kit de extensión!

El kit de extensión contiene un conector base, tanto la parte #8447 o la #7601

Paso 7: la ventana del tejado puede estar situada solamente en uno de los dos paneles centrales del techo.

Si monta el invernadero con un módulo de extensión, las ventanas del tejado deben ser colocadas en los paneles sólo como se especifica en el manual.

* **Nota:** la colocación seleccionada afectará a los próximos pasos del montaje.

Paso 8: Por favor, asegúrese de colocar el perfil y los tornillos de acuerdo con la ubicación de la ventana (**Paso 7**)

Paso 41: en caso de que la ventana no se cierre correctamente, por favor vaya al **Paso 40b**, afloje los tornillos, ajuste el perfil y apriete el tornillo.

Pasos 44: Pele la película que cubre el panel. Asegúrese de instalarla con el lado con protección UV hacia afuera.

Paso 53: seleccione el anclaje adecuado en función de la base existente. Los tornillos y anclajes de mampostería no están incluidos.

Important Recommendations

- **Ajuste firmemente el invernadero en una posición nivelada inmediatamente después de completar su montaje.**
- **Por favor, tenga en cuenta: Anclar este producto al suelo es esencial para su estabilidad y rigidez. Es necesario completar esta fase para que su garantía sea válida.**
- **Apriete todos los tornillos de montaje al completar.**

- Los tornillos 411 y tuercas 466 se utilizan en todo el proceso de montaje.
- Los tornillos 411 se deben atornillar desde el exterior y las tuercas 466 desde el interior del invernadero.
- Si no se especifica lo contrario, no apriete los tornillos y las tuercas (411 y 466) más de 2-3 vueltas. No los apriete hasta la finalización del montaje de los paneles. Estos 2 iconos indican si se requiere apretar el tornillo o no.
- Sin embargo, en algunos pasos, se puede necesitar el apriete temporal de algunos tornillos para evitar que un perfil se deslice fuera.

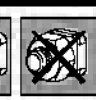
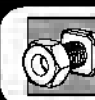

VIKTIG!

Les disse anvisningene nøye før montering, og ta vare på dem for fremtidig bruk.

» Sikkerhetsanvisninger

- Utfør monteringen i henhold til disse anvisningene.
- Bruk vernehansker.
- Bruk sko og vernebriller ved arbeid med aluminiumsprofiler.
- Følg produsentens sikkerhetsanvisninger for verktøy og annet utstyr.
- Pass på at aluminiumsprofilene ikke kommer i kontakt med strømkabler eller ledninger.
- Ikke forsøk å montere produktet når det blåser eller regner.
- Emballasjen skal avhendes i henhold til gjeldende regler. Oppbevar plastposer utilgjengelig for barn – kvelningsfare.
- Hold barn på trygg avstand fra arbeidsområdet.
- Ikke trykk eller vipp på produktet under monteringen.
- Ikke plasser produktet slik at det utsettes for sterk vind.
- Forsøk aldri å montere produktet hvis du er trøtt eller påvirket av narkotika, legemidler eller alkohol.
- Oppbevar aldri varme gjenstander i drivhuset. Kontroller at det ikke ligger skjulte rør eller kabler i bakken før du trykker ned pinnene.
- Produktet må kun brukes som drivhus.
- Dette produktet ble laget for å brukes i hovedsak som drivhus.
- **Merk:** Drivhuset må festes direkte på et solid underlag. Sørg for at det ikke er hindringer mellom monteringsområdet og den endelige plasseringen.

» Vedlikehold og rengjøring

- Rengjør produktet med mildt rengjøringsmiddel og skyll med kaldt vann.
- Bruk ikke aceton, slipende rengjøringsmidler eller andre kjemikalier på de gjennomskjete delene.

» Verktøy

- Arbeidshansker
- Stjerneskrutrekker
- Justerbar skiftenøkkel/skrunøkkel
- Vater
- Målbånd
- Gardintrapp
- Saks
- Elektrisk skrutrekker (10 mm, 7 mm, stjerne)
- Smøremiddel (valgfritt)
- T001 – spesialverktøy for skruer 411 og muttre 412



» Før sammensetning

- Velg et egnet sted:
 - Drivhuset må plasseres og festes på et flatt underlag.
 - Velg en solrik beliggenhet uten overhengende trær.
- Vi anbefaler sterkt at dette drivhuset plasseres direkte på et betongunderlag. For dette formålet bruker du de forhåndsdrillede hullene i metallbasen.
- Denne flerdelte monteringen oppnås best av to personer. Beregn minst en halv dag for monteringsprosessen.
- Ta alle komponentene ut av emballasjen. Sorter delene og sjekk at alt er der iflg. delelista. Delene bør legges ut slik at du lett kan nå dem. Hold alle små deler (skruer osv) i en bolle slik at de ikke forsvinner.
- Legg merke til at flersidige profiler er brukt i dette drivhuset. Dette betyr at enkelte av hullene profilene ikke blir brukt under monteringen.
- Gå gjennom alle instruksjonene før du starter. Utfør monteringstrinnene i nøyaktig orden.
- Tegningen i denne håndboken er beregnet på 8 x 8' drivhus + 4' utvidelsessett. Vær oppmerksom på at listen over innhold gjelder kun for 8 x 8 drivhus.
- Merk:** Alle trinnene for utvidelsesmodulen er merket med stiplede linje, og skal utføres under montering av drivhuset.

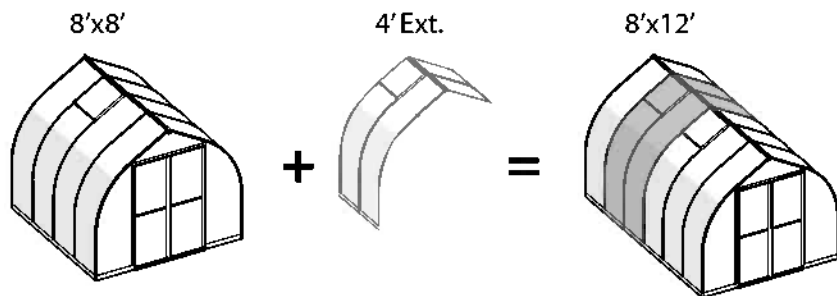

Modell	Lengde på underlaget	Ant. pakker
Bella (8' x 8')	244 cm / 96.1"	1
Bella + 4' Ext. (8' x 12')	363 cm / 142.9"	2
Bella + 4' Ext. x 2 (8' x 16')	482 cm / 189.8"	3
Bella + 4' Ext. x 3 (8' x 20')	601 cm / 236.6"	4

» Under montering

- Kontroller at underlaget er kvadratisk. Dette gjør du ved å måle diagonalene og bruke et vater.
- Trekk av filmen på platen. Kontroller at det monteres med den UV-beskyttede siden vendt ut.
- Du kan bruke et smøremiddel som f.eks. silikonspray til å gjøre det enklere å skyve platene inn i profilene.
- Ikke spray på polykarbonatplatene.
- Bruk en gummiklubbe hvis nødvendig.
- Alle paneler som er merket med teksten "THIS SIDE OUT" (Denne side ut) må vende ut for å oppnå full UV-beskyttelse. Fjern plastklistremerkene etter hvert som panelene låses på plass.

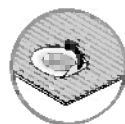

Når du ser informasjonsikonet, se det relevante monteringsstrinnet for flere kommentarer og mer hjelp.



Dette symbolet indikerer at montøren skal befinne seg på utsiden.



Dette symbolet indikerer at montøren skal befinne seg på innsiden.

Trinn 3: Gjelder kun for utvidelsessettet! Utvidelsessettet inneholder en del for tilkobling til underlaget, enten del **nr. 8447** eller **nr. 7601**

Trinn 7: Takvinduet kan kun plasseres på ett av de to midtre takpanelene.

Hvis du monterer drivhuset med en utvidelsesmodul, må du plassere takvinduet kun slik det er spesifisert i håndboken.

* **Merk:** Den valgte plasseringen påvirker de neste monteringsstrinnene.

Trinn 8: Sørg for at du plasserer profiler og skruer i henhold til plasseringen av vinduet (**trinn 7**)

Trinn 41: Hvis vinduet ikke kan lukkes ordentlig, må du gå til **trinn 40b**, løsne skruene, justere profilen og stramme skruen.

Trinn 44: Trekk av filmen på platen. Kontroller at det monteres med den UV-beskyttede siden vendt ut.

Trinn 54: Velg korrekt forankring i henhold til det eksisterende underlaget. Skruer og forankringer til mur medfølger ikke.



Important Recommendations

- **Fest drivhuset godt til et underlag Posisjoner straks etter at monteringen er fullført.**
- **Forankring av drivhuset kan også gjøres ved å drille baseprofilen og feste den til bakken ved å benytte bakkeskruer (skruer følger ikke med).**
- **Stram alle skruene etter monteringen er fullført.**

- Skruer 411 og muttre 466 brukes gjennom hele monteringen.
- Skruer 411 skal monteres fra utsiden, og muttre 466 skal monteres på innsiden av drivhuset.
- Hvis ikke noe annet er oppgitt, skal du ikke stramme skruer og muttre (411 og 466) mer enn 2-3 omdreininger. Ikke stram dem før du har montert alle platene. Disse to symbolene angir om du skal stramme skruen eller ikke.
- I enkelte trinn er det imidlertid nødvendig å stramme ett par skruer midlertidig for å hindre at en profil glir ut.

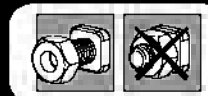

WAŻNE

Przed przystąpieniem do montażu szklarni prosimy o uważne zapoznanie się z instrukcją. Zachowaj tę instrukcję w bezpiecznym miejscu do przyszłego użytku.

» Customer Service

W celu uzyskania dodatkowych informacji oraz w sprawie części zamiennych odwiedź naszą stronę internetową albo skontaktuj się z nami telefonicznie (numer podany jest na stronie tytułowej). Dodatkowe informacje można znaleźć na naszej stronie internetowej : www.palamapplications.com

» Obsługa klienta

- Montaż części zgodnie ze wskazówkami jest niezwykle istotny. Nie pomiń żadnego kroku.
- Stanowczo zalecamy stosowanie rękawiczek ochronnych podczas montażu.
- Zawsze noś buty i gogle ochronne podczas pracy z półobrobionym aluminium.
- Podczas korzystania z drabiny lub elektronarzędzi, upewnij się, że postępujesz zgodnie z zaleceniami bezpieczeństwa producenta.
- Nie dotykaj aluminiowymi profilami okablowania powietrznego.
- Nie próbuj montować szklarni w niekorzystnych warunkach atmosferycznych takich jak wiatr lub deszcz.
- Należy usunąć wszystkie plastikowe torby i trzymać je poza zasięgiem dzieci.
- Trzymaj dzieci z dala od miejsca wykonywania montażu.
- Do not lean against or push the greenhouse during construction.
- Nie ustawiaj szklarni w miejscu wystawionym na działanie silnego wiatru.
- Nie należy wykonywać montażu w przypadku odczuwania zmęczenia, znajdowania się pod wpływem środków odurzających, leków, alkoholu lub w przypadku podatności na zawroty głowy.
- Nie należy przechowywać w szklarni gorących przedmiotów takich jak niedawno używany grill, palniki etc.
- Ten produkt jest zaprojektowany do użytku głównie jako szklarnia.
- **Uwaga:** Powinieneś przymocować szklarnię bezpośrednio do stałego podłoża; Upewnij się, że nie ma żadnych przeszkód pomiędzy miejscem montażu i ostateczną pozycją.

» Pielęgnacja i Konserwacja

- Kiedy Twoja szklarnia wymaga czyszczenia należy użyć do tego delikatnego środka czyszczącego i spłukiwać zimną wodą.
- Do mycia paneli NIE UŻYWAJ acetonu, ściernych środków czyszczących ani innych substancji chemicznych.

» Narzędzia i sprzęt

- Rękawice ochronne
- Śrubokręt Phillips
- Regulowany klucz nastawny / nasadowy
- Poziomica
- Taśma pomiarowa
- Drabina
- Nożyczki
- Śrubokręt elektryczny
- Lybrykant (Opcjonalny)
- T001 – Specjalne narzędzie do śrub 411 i nakrętek 412



» Przed montażem

- Wybór miejsca:
 - Szklarnia powinna zostać ustawiona i zamontowana na stałej i płaskiej powierzchni.
 - Wybierz słoneczne miejsce z dala od drzew, które by je zacieniały.
- Stanowczo zalecamy umocowanie tej szklarni bezpośrednio na jednolitej, betonowej podstawie.
- Montaż składa się z wielu elementów, zaleca się zatem, by przeprowadzili go dwie osoby. Na montaż należy przeznaczyć przynajmniej pół dnia.
- Wyjmij wszystkie elementy z opakowań. Posortuj je i sprawdź z listą zawartości. Elementy powinny być umieszczone w zasięgu. Trzymaj wszystkie małe elementy (śrubki itp.) w misce aby się nie zgubiły.
- Prosz pamiętać, że w tej szklarni wykorzystywane są wielokształtne profile. W wyniku tego niektóre otwory w profilach nie są wykorzystywane podczas montażu.
- Przed rozpoczęciem proszę zapoznać się z całą instrukcją obsługi. Postępuj zgodnie z instrukcjami we wskazanej kolejności.
- Rysunki w tym poradniku są przeznaczone do szklarni 8' x 8' 4" Zestaw rozszerzający. Zwróć uwagę na to, że lista zawartości dotyczy jedynie szklarni 8x8

Zauważ: wszystkie kroki modułów do rozbudowy, które są zaznaczone linią przerywaną, powinny zostać wykonane podczas procesu montażu szklarni.

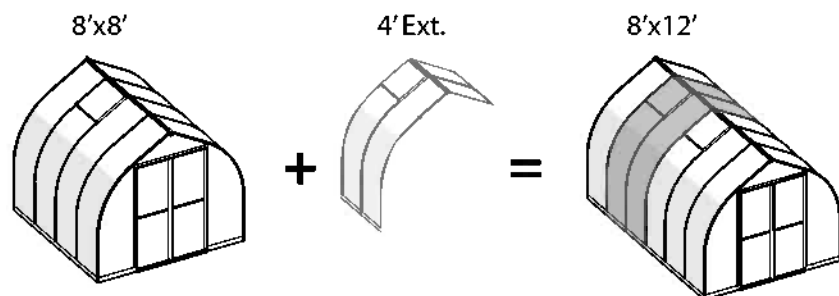

Model	Długość podstawy	Ilość paczek
Bella (8' x 8')	244 cm / 96.1"	1
Bella + 4' Ext. (8' x 12')	363 cm / 142.9"	2
Bella + 4' Ext. x 2 (8' x 16')	482 cm / 189.8"	3
Bella + 4' Ext. x 3 (8' x 20')	601 cm / 236.6"	4

» Podczas Montażu

- Upewnij się, że podstawa jest kwadratowa poprzez pomiar przekątnych oraz, że jest równa, używając poziomicy.
- Zdejmij warstwę pokrywającą panel. Upewnij się, że zainstalujesz go stroną z ochroną UV na zewnątrz.
- Możesz użyć silikonowego lubrykantu w sprayu aby wspomóc wsunięcie paneli do profili.
- Nie stosuj sprayu na panelach poliwęglanowych.
- W razie potrzeby użyj gumowego młotka.
- Wszystkie panele oznaczone THIS SIDE OUT muszą być zwrócone na zewnątrz aby stworzyć pełną ochronę UV. Usuń plastikową naklejkę po umieszczeniu paneli na miejscach.

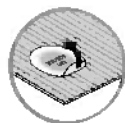

Ikony informacyjne, które napotkasz podczas montażu wskazują na konieczność zapoznania się z dodatkowymi informacjami dotyczącymi danego etapu montażu.



Ta ikona wskazuje na to, że osoba montująca powinna znajdować się w środku produktu.



Ta ikona wskazuje na to, że osoba instalująca powinna znajdować się na zewnątrz produktu.

Krok 3: Odnosi się tylko do zestawu rozszerzającego! Zawiera on elementy przyłącznikowe, część #8447 lub #7601

Krok 7: Okno dachowe powinno znajdować się tylko na jednej z dwóch centralnych paneli dachowych.

Jeśli montujesz szklarnię z modułem do rozbudowy, okna dachowe powinny znajdować się na panelach wyłącznie w sposób wskazany w poradniku.

* **Zauważ:** Wybrane ustawienie będzie wpływać na kolejne kroki montażu.

Krok 8: Upewnij się, aby umieścić profile i śruby zgodnie z położeniem okna (**Krok 7**)

Krok 41: W przypadku kiedy okno nie zamyka się właściwie wróć do punktu **40b**, poluzuj śruby, dostosuj profil i dokręć śruby.

Krok 44: Ściągnij warstwę pokrywającą panel. Upewnij się, żeby zamontować go stroną ochronną UV na zewnątrz.

Krok 53: Wybierz odpowiednie zakotwiczenie zgodnie z istniejącym podłożem. Śruby i kotwy murarskie nie są zawarte w zestawie.



Ważne wskazówki

- Pewnie umocuj szklarnię w równej pozycji natychmiast po zakończeniu montażu.
- Zakotwiczenie produktu do ziemi jest kluczowe dla jego stabilności i sztywności. Aby Państwa gwarancja zachowała ważność niezbędne jest wykonanie tego etapu.
- Dokręć wszystkie śruby po zakończeniu montażu.

- Śruby 411 i nakrętki 466 używane są w trakcie trwania całego procesu montażu.
- Śruba 411 powinna być włożona od zewnątrz, a nakrętka 466 od wewnątrz szklarni.
- Nie dokręcaj śruby 411 i nakrętki 466 o więcej niż 23 obroty. Jeżeli nie podano inaczej, nie należy ich dokręcać, dopóki wszystkie panele nie zostaną zamontowane. Te 2 ikony wskazują czy dokręcenie śruby jest wymagane czy nie.
- Podczas wykonywania niektórych etapów montażu konieczne może okazać się czasowe mocne dokręcenie kilku śrub w celu uniknięcia zapadnięcia się rusztowania.



Viktigt

Läs noga igenom dessa instruktioner innan ni börjar montera växthuset.
Förvara dessa instruktioner på en säker plats för framtida referenser.

» Kundservice

För rådgivning av montering eller byte av delar – vänligen kontakta oss via e-mail eller telefon (nummer finns på förstasidan).

Ytterligare information finns på producentens hemsida: www.palamapplications.com

» Säkerhetsföreskrifter

- Följ monteringsanvisningarna i den ordning som anvisas i instruktionerna, hoppa inte över något steg.
- Vi rekommenderar att handskar, skor och skyddsglasögon alltid används då man arbetar med metallprofiler.
- Vid användning av stega, redskap och bormaskin, följ tillverkarens säkerhetsråd.
- Var noga med att inte komma i kontakt med elkablar då metallprofiler hanteras.
- Undvik att montera växthuset i dåligt, blåsigt väder eller regn.
- Ta väl hand om all plastpåsar och se till att de är utom räckhåll för barn.
- Låt inte barn vistas på monteringsplatsen och håll omgivningen snygg.
- Luta eller tryck inte på växthuset under montering.
- Välj omsorgsfullt platsen för växthuset så att det inte påfrestras av kraftig vind eller extra snö.
- Försök inte att sätta ihop denna produkt om du är trött, har tagit droger, druckit alkohol eller om du brukar ha yrselattacker.
- Heta föremål som en nyligen använd grill, blåslampa eller dylikt får inte förvaras i växthuset. Försäkra att det inte finns några dolda rör eller kablar i marken innan du slår ner metallfästena för att förankra växthuset.
- Denna produkt har utformats för att huvudsakligen användas som en växthus.
- **Obs:** Du bör förankra växthuset direkt på en fast grund; Se till att det inte finns några hinder mellan monteringsområdet och den slutliga positionen.

» Underhåll & skötsel

- När växthuset behöver rengöras skall du använda ett mildt rengöringsmedel och skölja rikligt med kallt och rent vatten.
- Använd inte acetone, slipande rengöringsmedel eller andra specialmedel för att rengöra panelerna. Vi rekommenderar att man tidvis kontrollerar takpanelernas fäste (även plastfästen 329 och profiler 981) och försäkrar deras rätta position.

» Verktyg & redskap

- Arbetshandskar
- Stjärnskruvmejsel
- Skiftnyckel/Skruvnyckel
- Utjämnare
- Måttband
- Trappstege
- Sax
- Elskruvmejsel (10 mm, 7 mm, stjärn)
- Smörjmedel (Valfritt)
- T001 - Specialverktyg för Skruvar 411 och muttrar 412



» Före montering

- Val av plats:
 - Växthuset måste placeras på en fast och plant underlag.
 - Välj en solig plats utan överhängande träd.
- Vi rekommenderar absolut att detta växthus säkras direkt på en solid cementgrund. När detta görs bör man använda de förborrade hålen i metallramen..
- Detta är en montering av flera delar och görs bäst av två personer. Räkna med minst en halv dag för monteringsprocessen.
- Ta ut alla komponenter ur förpackningen. Sortera delarna och kontrollera mot komponentlistan. Delarna bör läggas ut nära dig. Ha alla små delar (skruvar etc.) i en skål så att de inte försvinner.
- Lägg märke till att flerkantsprofiler används i växthuset. Ett resultat av detta är att några av hålen inte används under monteringen.
- Läs igenom instruktionerna innan du startar. Utför monteringsstegen i exakt ordning.
- Ritningarna i denna manual är utformade för 8' x 8' växthus + 4' utbyggnadssats. Observera att innehållslistan endast hänvisar till 8x8 växthus.

Obs: alla stegen för utbyggnadsmodulen är markerade med en streckad kontur och skall utföras under växthusets monteringsprocess.

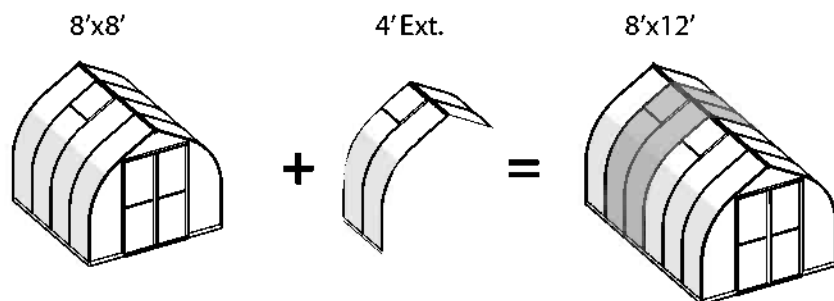

Modell	Baslängd	Antal paket
Bella (8' x 8')	244 cm / 96.1"	1
Bella + 4' Ext. (8' x 12')	363 cm / 142.9"	2
Bella + 4' Ext. x 2 (8' x 16')	482 cm / 189.8"	3
Bella + 4' Ext. x 3 (8' x 20')	601 cm / 236.6"	4

» Under montering

- Se till att basen är kvadratisk genom att mäta diagonalerna och jämna ut med hjälp av ett vattenpass.
- Skala av filmen som täcker panelen. Se till att du installerar den med den UV-skyddade sidan utåt.
- Du kan använda silikonsmörjsprej för att hjälpa dig att skjuta in panelerna i profilerna.
- Spreja inte polykarbonatpanelerna.
- Använd en gummiklubba om så behövs.
- Alla paneler med de stämplade orden THIS SIDE OUT måste vara vända utåt för att skapa fullt UV-skydd. Ta bort plastetikett när paneler är låsta på plats.

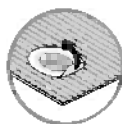

i När man påträffar informationsikonen, se motsvarande monteringssteg för ytterligare kommentarer och hjälp



Denna ikon anger att installatören bör befinna sig inne i produkten.



Denna ikon anger att installatören bör befinna sig utanför produkten.

Steg 3: Avser endast till förlängningssatsen! Förlängningssatsen innehåller en basanslutning, antingen del # 8447 eller # 7601

Steg 7: Takfönster kan endast placeras på en av de två centrala takpanelerna.

Om du monterar växthuset med en utbyggnadsmodul, måste takfönstren placeras på paneler endast på det sätt som anges i manualen.

* Obs: Den valda placeringen kommer att påverka de efterföljande monteringsstegen.

Steg 8: Se till att du placerar profil och skruvar enligt fönsterplaceringen (**Steg 7**)

Steg 41: Om fönstret inte är ordentligt stängt, var god gå till **Steg 40b**, lossa skruvarna, justera profilen och dra åt skruven.

Steg 44: Skala av filmen som täcker panelen. Se till att du installerar den med den UV-skyddade sidan utåt.

Steg 53: Välj rätt förankring beroende på den befintliga basen. Skruvar och murverksförankringar medföljer inte.



Viktiga rekommendationer

- Sätt fast växthuset på ett horisontellt plant underlag efter att monteringen är klar.
- Förankring av denna produkt på marken är nödvändigt för stabilitet och styvhet. Det är nödvändigt att slutföra det här steget för att din garanti ska gälla.
- Dra åt alla skruvar när du slutför monteringen.

- Skruvar 411 och muttrar 466 används i hela monteringsprocessen.
- Skruvar 411 ska monteras från utsidan och muttrar 466 från insidan av växthuset.
- Om inget annat anges, skruva inte åt skruvar och muttrar (411 och 466) mer än 2-3 varv. Skruva inte åt dem förrän monteringen av panelerna slutförts. Dessa 2 ikoner indikerar om skruvåtdragning krävs eller inte.
- I vissa steg kan dock åtdragning av några skruvar behövas för att förhindra att en profil glider ut.

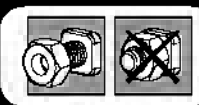
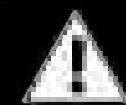

TÄRKEÄÄ

Lue ensin huolellisesti nämä ohjeet ennen kasvihuoneen asentamista..
Säilytä nämä ohjeet turvassa vastaisuuden varalta

» Asiakas palvelu

Jos tarvitset apua / neuvoja asennukseen tai osien vaihtoon – käänny meidän kotisivujen, sähköpostin puoleen tai soita jälkimarkkinointiimme (tiedot löytyvät kansilehdestä).

Lisäinformaatiota löydät valmistajan sivuilta www.palramapplications.com

» Turvallisuus ohje

- Ensisijaisen tärkeätä on noudattaa asennusohjeen järjestystä ja ohjeita – älä jätä mitään tekemättä.
- Suosittelemme suojakäsineiden käyttöä asennustyössä.
- Käytä aina tukevia kenkiä ja suojalaseja työskennellessäsi metallituotteiden kanssa.
- Jos käytät tikkaita, apuvälineitä, akkuporakonetta - varmista aina myös työkalu valmistajan käyttöohjeet.
- Älä kosketa sähköjohtoja tai lähteitä metallisten esineiden kanssa.
- Älä yritä pystyttää / asentaa kasvihuonetta tuulisella, sateisella tai huonolla säällä.
- Hävitä huolellisesti kaikki muoviset pakkaustuotteet ja varmista ettei ne pääse pienten lasten lähetyville.
- Pidä lapset loitolla työskentely alueelta ja pidä myös alue aina siistinä.
- Älä työnnä tai nojaa kasvihuoneen rakenteisiin asennusvaiheen aikana.
- Valitse huolella kasvihuoneen sijainti, siten ettei se ole alttiina kovalle tuulelle tai ylimääräisille lumikuormille.
- Älä yritä asentaa tätä kasvihuonetta puolikuntoisena, väsyneenä, päihteiden taikka lääkityksen vaikutuksen alaisena.
- Kuumat tuotteet kuten grillit, polttotyökalut, terassilämmittimet tulee säilöä muulla kuin kasvihuoneessa. Varmista että maahankiinnitys on turvallista ja ettei maaperässä ole putkia tai sähköjohtoja.
- Tämä tuote on suunniteltu käytettäväksi pääosin as kasvihuoneeksi.
- Huomaa: kasvihuone on kiinnitettävä suoraan kiinteälle perustalle; varmista, että kokoamisalueen ja lopullisen sijainnin välillä ei ole esteitä.

» Huolto & ylläpito

Kun kasvihuoneesi kaippaa pesua & puhdistusta, käytä ainoastaan mietoja saippuavettä ja huuhtelee runsaalla kylmällä vedellä. ÄLÄ KÄYTÄ acetoonia, liuottimia tai muita voimakkaita puhdistusaineita – ei myöskään mäntyöljypohjaisia aineita. On suositeltavaa että asennuksen kunto tarkistetaan säännöllisesti, kattolevyt > kiinnikkeet (muoviset osat 329 & profilit 981) ovat paikoillaan.

» Työkalut & Välineet

- Työkäsineet
- Phillipsin ruuvimeisseli
- Säädettävä kiintoavain
- Tasoitin
- Mittanauha
- Tasotikkaat
- Sakset
- Sähköruuvimeisseli (10 mm, 7 mm, Phillips)
- Voiteluaine (Valinnainen)
- T001 - Erityistyökalu ruuveille 411 ja muttereille 412

**» Ennen kokoamista:**

- Sijainnin valinta:
 - Kasvihuone tulee asettaa ja kiinnittää tasaiselle alustalle.
 - Valitse aurinkoinen paikka, jonka yllä ei roiku oksia.
- Suosittelemme, että tämä kasvihuone kiinnitetään suoraan kiinteään betonialustaan. Tällöin voit käyttää metallipohjaan valmiiksi ruuvattuja reikiä.
- Kokoaminen on moniosainen työ, jonka suorittaa parhaiten kaksi henkilöä. Varaa ainakin puoli päivää kokoamisprosessille.
- Ota kaikki osat ulos pakkauksistaan. Lajitele osat ja tarkista sisällysluettelosta, että ne ovat kaikki tallella. Osat tulee asetella käden ulottuville. Pidä pienet osat (ruuvit yms.) kulhossa, jotta ne eivät katoa.
- Huomaa, että tässä kasvihuoneessa käytetään monisivuisia tukirankoja, joten kaikkia niissä olevia reikiä ei käytetä kokoamiseen.
- Lue koko käyttöohje ennen aloittamista. Suorita kokoamisvaiheet tarkassa järjestyksessä.
- Tämän ohjekirjan piirustukset on suunniteltu 8' x 8' -kasvihuoneelle + 4' -laajennusarjalle. Huomioithan, että pakkaussisällöllä viitataan ainoastaan 8x8-kasvihuoneeseen.

Huomaa: kaikki laajennusmoduulin vaiheet on merkitty ääriivoin, ja ne tulisi suorittaa kasvihuoneen kokoamisen yhteydessä.

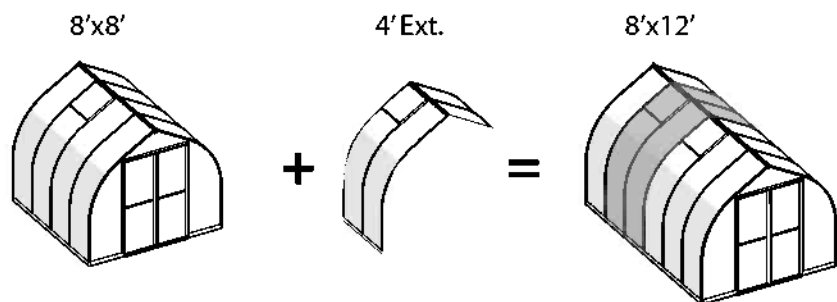

Malli	Pohjan pituus	Pakkausten lukumäärä
Bella (8' x 8')	244 cm / 96.1"	1
Bella + 4' Ext. (8' x 12')	363 cm / 142.9"	2
Bella + 4' Ext. x 2 (8' x 16')	482 cm / 189.8"	3
Bella + 4' Ext. x 3 (8' x 20')	601 cm / 236.6"	4

» Kokoamisen aikana

- Varmista, että pohja on suorakulmainen mittaamalla kulmat, ja tasaa käyttäen vatupassia
- Kuori kalvo paneelin päältä. Varmista, että asennat sen UV-suojattu puoli ulospäin.
- Voit käyttää silikonisprayta apuna paneelien liu'uttamisessa profiileihin.
- Älä käytä sprayta polykarbonaattipaneeleihin.
- Käytä tarvittaessa kumivasaraa.
- Kaikkien "THIS SIDE OUT" -tekstillä varustettujen paneelien on osoitettava ulospäin täyden UV-suojan takaamiseksi. Poista muovitarra, kun paneelit on lukittu paikoilleen.

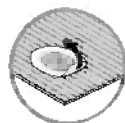

Asennuksen aikana tulet kohtaamaan tietokuvake katso asiaa kokoonpanoon askel lisäkommentteja ja apua.



Tämä kuvake osoittaa, että asentaja pitäisi olla tuotteen ulkopuolella



Tämä kuvake osoittaa että asentajan pitäisi olla tuotteen sisällä

Vaihe 3: Viittaa ainoastaan laajennuspakettiin! Laajennuspaketti sisältää alusliittimen, joko osan #8447 tai #7601

Vaihe 7: Kattoikkuna voi olla vain toisessa katon keskipaneeleista.

Jos kokoat kasvihuoneen laajennusmoduulilla, kattoikkunat on sijoitettava paneeleihin vain ohjekirjassa määritetyllä tavalla.

* **Huomaa:** valittu sijoitus vaikuttaa seuraaviin kokoamisvaiheisiin. Vaihe 8: varmistathan, että sijoitat profiilin ja ruuvit ikkunan sijainnin mukaan

Vaihe 8: varmistathan, että sijoitat profiilin ja ruuvit ikkunan sijainnin mukaan (**Vaihe 7**)

Vaihe 41: mikäli ikkunaa ei ole suljettu kunnolla, siirry kohtaan **40b**, avaa ruuvit, säädä profiilia ja kiristä taas ruuvit.

Vaihe 44: kuori kalvo paneelin päältä. Varmista, että asennat sen UV-suojattu puoli ulospäin.

Vaihe 53: valitse sopiva kiinnitystapa olemassa olevan pohjan mukaan. Pakkauksessa ei ole mukana ruuveja eikä betonikiinnikkeitä.



Tärkeitä suosituksia

- **Kiinnitä kasvihuone tukevasti vaakasuoralle alustalle heti kokoamisen jälkeen.**
- **tuotteen ankkurointi maahan on välttämätöntä sen vakauden ja jäykkyyden kannalta. Se vaaditaan tässä vaiheessa, jotta takuu olisi voimassa.**
- **Kiristä kaikki ruuvit täyttäessään kokoonpano.**

- Ruuveja 411 ja muttereita 466 käytetään läpi kokoamisprosessin.
- Ruuvit 411 tulee kiinnittää kasvihuoneen ulkopuolelta ja mutterit 466 sen sisäpuolelta.
- Ellei toisin ole määriteltä, älä kiristä ruuveja ja muttereita (411 & 466) enempää kuin 2-3 kierrosta. Älä kiristä niitä ennen kuin paneelien kokoaminen on suoritettu loppuun. Nämä 2 symbolia kertovat, tuleeko ruuvit kiristää vai ei.
- Joissakin vaiheissa kuitenkin muutaman ruuvin kiristäminen väliaikaisesti voi olla tarpeen, jotta estettäisiin profiilin liukuminen ulos.



TÄHTIS

Palun lugege kasutusjuhised hoolikalt läbi enne kui hakkate oma kasvuhoonet kokku panema.

Hoidke need juhised turvalised kohas edaspidiseks kasutamiseks

» Klienditeenindus

Abiks kokkupanemisel Kokkupanekul abisaamiseks kirjutage tiitellehel näidatud emailile.

Lisainformatsiooni võib leida veebilehelt: www.palramapplications.com

» Ohutusjuhised

- Soovitage tungivalt kasutada kokkupanekul töökindaid.
- Kandke alati jalanõusid ja kaitseprille kui töötate pressitud alumiiniumiga.
- Kasutades redelit või elektritööriistu, veenduge, et järgite tootjapoolseid ohutusjuhiseid.
- Ärge üritage kasvuhoonet kokku panna tuulistes või niisketes tingimustes.
- Visake kõik plastikkotid Ohutuse eesmärgil visake plastikkotid koheselt ära, need pole sobilikud lastele mängimiseks- võivad põhjustada lämbumisohu.
- Hoidke lapsed kokkupanemisalast eemal.
- Ärge nõjatuge kasvuhooone vastu või lükake seda kokkupanekul.
- Ärge asetage oma kasvuhoonet Ärge paigaldage kasvuhoonet tuulisesse kohta.
- Ärge üritage kasvuhoonet kokku panna kui olete väsinud, kasutate ravimeid, olete tarbinud alkoholi või olete uimane.
- Kuumad esemed, nagu hiljuti kasutatud grill, leeklamp jm ei tohi hoida kasvuhooones. Veenduge, et varjatud torusid või kaablit poleks maapinnas enne vaiade sisestamist.
- See toode on konstrueeritud kasutamiseks peamiselt kui kasvuhooone.
- **Märkus:** kasvuhooone tuleks kinnitada otse kõvale pinnale; veenduge, et kokkupaneku- ja paigalduskoha vahel pole takistusi

» Hooldus ja korrashoid

- Kui Teie kasvuhooone vajab puhastamist, kasutage pehmet puhastusvahendit ja loputage külma, puhta veega.
- **ÄRGE KASUTAGE** atsetooni, abrasiivseid puhastusaineid või teisi lahuseid paneelide puhastamiseks. On perioodiliselt soovitatav kontrollida, et katusepaneelide vahed (plastosad 329 ja profiil 981) oleksid omal kohal.

» Tööriistad ja varustus

- töökindad
- Phillipsi lamepeakruvikeeraja
- tellitav mutrivõti
- lood
- mõõdulint
- treppredel
- käärid
- elektriline kruvikeeraja (10 mm, 7 mm, Phillips)
- määrdeaine (valikuline)
- T001 – spetsiaalne tööriist kruvidele 411 ja mutritele 412



» Enne paigaldamist

- Koha valimine:
 - Kasvuhooone tuleb paigaldada ja kinnitada tasasele pinnale.
 - Vali päikseline asukoht, kus ei oleks varjuheitvaid puid.
- Soovitame kinnitada kasvuhooone kindlale betoonist vundamendile. Selleks kasutage metallpõhjas olevaid eelnevalt valmis puuritud auke.
- See on mitmest osast koosnev struktuur, mille paigaldamist on parim teha kahe inimesega. Paigaldamine võtab aega vähemalt pool päeva.
- Võta kõik komponendid pakendist välja. Sorteeri detailid ning kontrolli detailide nimekirja alusel, kas kõik on olemas. Soovitame asetada detailid käeulatusse. Hoia väikeseid osi (kruvisid jms) kausis, et need ära ei kaoks.
- Pea silmas, et selles kasvuhooones kasutatakse mitme küljega profile. Seetõttu jäävad paigaldamisel mõned augud kasutamata.
- Enne alustamist loe kõik juhised läbi. Paigaldamist tee täpselt juhendist toodud järjekorras.
- Selle kasutusjuhendi joonised vastavad 8' x 8' kasvuhooonele + 4' pikenduskomplektile. Pange tähele, et osade loetelu kehtib ainult 8 x 8 kasvuhooonele.

Märkus: kõik pikendusmooduli sammud on märgitud katkendjoonega ja tuleks teha enne kasvuhooone kokkupanekut.

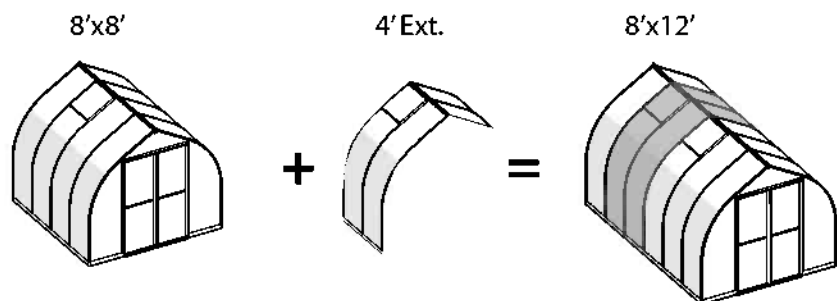

Mudel	Aluse pikkus	Pakendite arv
Bella (8' x 8')	244 cm / 96.1"	1
Bella + 4' Pikend (8' x 12')	363 cm / 142.9"	2
Bella + 4' Pikend x 2 (8' x 16')	482 cm / 189.8"	3
Bella + 4' Pikend x 3 (8' x 20')	601 cm / 236.6"	4

» Kokkupaneku ajal

- Veenduge, et alus on ruudukujuline; selleks mõõtke diagonaalid ja tasapind, kasutades vesiloodi.
- Tõmmake paneelilt kile. Veenduge, et paigaldamisel jääb UV-kaitsega pool väljapoole.
- Et paneelide libistamine profiilidesse oleks hõlpsam, võite kasutada silikoonmäärde spreid.
- Ärge pihustage polükarbonaatpaneelidele.
- Vajadusel kasutage kummivasarat.
- Kõigi paneelide THIS SIDE OUT templiga märgistatud pool peab jääma väljapoole, et tagada täielik UV-kaitse. Kui paneelid on paigas, siis eemaldage plastkleepsud. ds

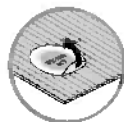

i Kui märkate informatsiooniikooni, vaadake täiendavaid märkuseid ja juhiseid vastava paigaldussammu alt.



See ikoon viitab sellele, et paigaldaja peaks paiknema toote sees.



See ikoon viitab sellele, et paigaldaja peaks paiknema väljaspool toodet.

Samm 3: käib ainult täienduse komplekti kohta! Täienduse komplekt sisaldab põhikonektorit, kas osa nr. **8447 või 7601**

Samm 7: katuseakent saab paigutada ainult ühele kahest kesksest katusepaneelist. Kui panete kasvuhoone kokku koos pikendusmooduliga, siis peate paigutama katuseaknad ainult nii, nagu juhendis on näidatud.

* **Märkus:** valitud paigutus mõjutab järgmisi kokkupanekusamme.

Samm 8: veenduge, et asetate profiilid ja kruvid vastavalt akna asukohale (**Samm 7**)

Samm 42: kui aken pole korralikult suletud, siis minge tagasi **sammu 40b** juurde, vabastage kruvid, kohandage profiili ja pingutage kruvi.

Samm 41: eemaldage paneelilt kattekile. Veenduge, et paigaldate selle, UV-kaitsega külg väljapoole.

Samm 53: valige põhjaga sobivad kinnitusankrud. Kruvid ja müüritise ankrud ei kuulu komplekti.

! Olulised soovitused

- Kinnita kasvuhoone kindlalt tasasele pinnale kohe peale selle kokkupanemist.
- Tähelepanu: toote pinnasesse ankurdamine on stabiilsuse ja jäikuse tagamiseks vältimatu. Selle etapi teostamine on garantii kehtimiseks kohustuslik.
- Pinguldage kruvid alles siis kui kasvuhoone on komplekteeritud.

- Kruvisid 411 ja mutreid 466 kasutatakse terve kokkupaneku vältel.
- Kruvid 411 tuleb asetada kasvuhoone väljapoole ja mutrid 466 seestpoolt.
- Kui pole määratud teisiti, siis ärge kinnitage kruvisid ja mutreid (411 & 466) tugevamini kui 2-3 pööret. Ärge pingutage neid enne, kui paneelid on kokku pandud. Need kaks ikooni näitavad, kas kruvide pingutamine on nõutav või mitte.
- Siiski võib mõnede sammude puhul olla kruvide ajutine pingutamine vajalik, et vältida profiili väljalibisemist.

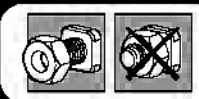

POMEMBNO

Pred sestavo tega proizvoda natančno preberite ta navodila.
Navodila hranite na varnem mestu za nadaljnjo uporabo.

» Storitve za stranke

Za pomoč pri sestavi ali za nadomestne dele – se prijavite na našo spletno stran ali pokličite na telefonsko številko, ki jo najdete na naslovni strani.

Dodatne informacije so vam na voljo na naši spletni strani: www.palramapplications.com

» Varnostni nasveti

- Zelo pomembno je, da vse dele sestavite v skladu z navodili.
Ne preskočite nobenega koraka.
- Priporočamo, da pri delu s paneli uporabljate delovne rokavice.
- Pri delu z ekstrudiranim aluminijem vedno nosite čevlje in zaščitna očala.
- Če uporabljate lestev ali električna orodja, poskrbite, da boste sledili varnostnim nasvetom proizvajalca.
- Ne dotikajte se električnih kablov z aluminijastimi profili.
- Rastlinjaka ne poskušajte sestavljati v vetrovnih in mokrih pogojih.
- Odstranite vse plastične vrečke. Hranite jih izven dosega majhnih otrok.
- Otroke držite stran od območja sestavljanja.
- Med postavljanjem rastlinjaka se ne naslanjajte nanj in ga ne potiskajte.
- Rastlinjaka ne postavite na območje, ki je izpostavljeno močnemu vetru.
- Ne poskušajte sestavljati rastlinjaka, če ste utrujeni, pod vplivom zdravil ali alkohola, ali če ste nagnjeni k omotici.
- V rastlinjaku ne smete shranjevati vročih predmetov, kot so nedavno uporabljeni žari, varilniki, itd. Prepričajte se, da v tleh ni skritih cevi ali kablov, preden vstavite kline.
- Ta proizvod je namenjen predvsem uporabi kot rastlinjak.
- **Opomba:** Rastlinjak morate zasidrati na trdno podlago. Prepričajte se, da med območjem sestavljanja in končnim položajem ni ovir.

» Ravnanje in vzdrževanje

- Ko boste rastlinjak želeli oprati, uporabite blago čistilno sredstvo in ga sperite s čisto mrzlo vodo.
- NE uporabite acetona, jedkih čistilnih sredstev ali drugih posebnih detergentov za čiščenje prozornih plošč.

» Orodja in oprema

- Delovne rokavice
- Phillipsov izvijač
- Nastavljivi viličasti ključ
- Libela
- Merilni trak
- Lestev
- Škarje
- Električni izvijač (10 mm, 7 mm, Phillips)
- Mazivo (opcijsko)
- T001 - Posebno orodje za vijake 411 in matice 412



» Pred sestavo

- Izbira mesta:
 - Rastlinjak mora biti postavljen in pritrjen na ravno površino.
 - Izberite sončno mesto proč od dreves z visečimi vejami.
- Močno priporočamo, da rastlinjak pritrдите na trdne betonske temelje.
- Gre za večdelno sestavo, zato priporočamo delo dveh oseb. Za postopek sestavljanja si vzemite vsaj pol dneva.
- Iz paketov vzemite vse komponente in dele. Razvrstite vse dele in jih preverite na seznamu delov.
- Dele postavite v bližino in naj bodo na dosegu rok. Vse majhne dele (vijaki, itd.) imejte v skledi, da se ne izgubijo.
- V tem rastlinjaku se uporabljajo večstranski profili. Zaradi tega se pri sestavi ne uporabijo vse luknje v profilih.
- Pred začetkom preberite celotna navodila. Korake sestave izvedite v natančno zapisanem zaporedju.
- Skice v tem priložniku so zasnovane za rastlinjak velikosti 8' x 8' + razširitveni komplet velikosti 4'. Upoštevajte, da se vsebinski seznam nanaša samo na rastlinjak velikosti 8x8.
- Opomba:** Vsi koraki razširitvenega modula so označeni s črtkanim orisom. Razširitev mora biti opravljena med postopkom sestave rastlinjaka.

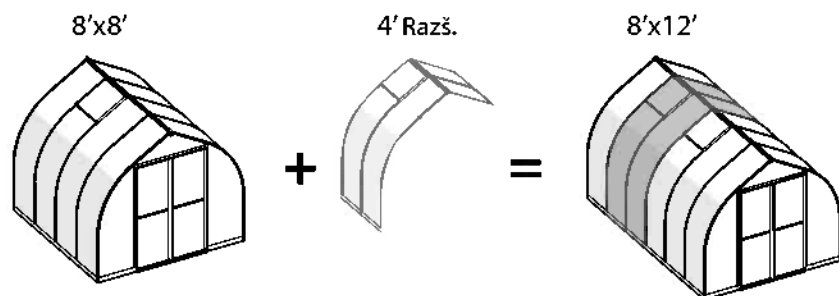

Model	Dolžina osnove	Št. paketov
Bella (8' x 8')	244 cm / 96.1"	1
Bella + 4' Razš. (8' x 12')	363 cm / 142.9"	2
Bella + 4' Razš. x 2 (8' x 16')	482 cm / 189.8"	3
Bella + 4' Razš. x 3 (8' x 20')	601 cm / 236.6"	4

» Med sestavo

- Z merjenjem diagonal se prepričajte, da je osnova kvadratna, z uporabo libele pa preverite, ali je osnova ravna.
- Odlepите folijo, ki prekriva panel. Poskrbite, da panel namestite tako, da bo stranica, ki je zaščiten pred UV žarki, na zunanji strani.
- Za pomoč pri potiskanju panelov v profile lahko uporabite silikonsko mazivo v spreju.
- Ne pršite polikarbonatnih panelov.
- Po potrebi uporabite gumijasto kladivo.
- Vsi paneli z napisom THIS SIDE OUT (zunanja stran) morajo biti obrnjeni navzven, da zagotovite popolno UV zaščito. Odstranite plastično nalepko, ko so paneli postavljeni na mesto.

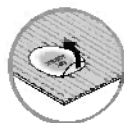

 Med sestavljanjem boste naleteli na informativno ikono. Za dodatne komentarje in pomoč si preberite ustrezen korak sestave.



Ta ikona pomeni, da mora biti sestavljaev znotraj proizvoda.



Ta ikona pomeni, da mora biti sestavljaev izven proizvoda.

Korak 3: Nanaša se samo na razširitveni komplet! Razširitveni komplet vsebuje spojnik za osnovo, del #8447 ali #7601

Korak 7: Strešno okno lahko namestite samo na eno od dveh osrednjih strešnih panelov.

Če rastlinjak sestavite z razširitvenim modulom, je treba strešna okna postaviti na panele tako, kot je določeno v priročniku.

* **Opomba:** Izbrana postavitev vpliva na naslednje korake sestavljanja.

Korak 8: Prepričajte se, da profil in vijake namestite glede na postavitev okna (**Korak 7**)

Korak 41: Če okno ni pravilno zaprto, pojdite na **korak 40b**, odvijte vijake, nastavite profil in ponovno zategnite vijake.

Korak 44: Odlepите folijo, ki prekriva panel. Poskrbite, da panel namestite tako, da bo stranica, ki je zaščiten pred UV žarki, na zunanji strani.

Korak 53: Izberite ustrezno sidranje glede na obstoječo osnovo. Vijaki in zidarska sidra niso priložena.



Pomembna priporočila





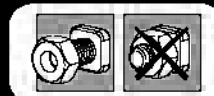

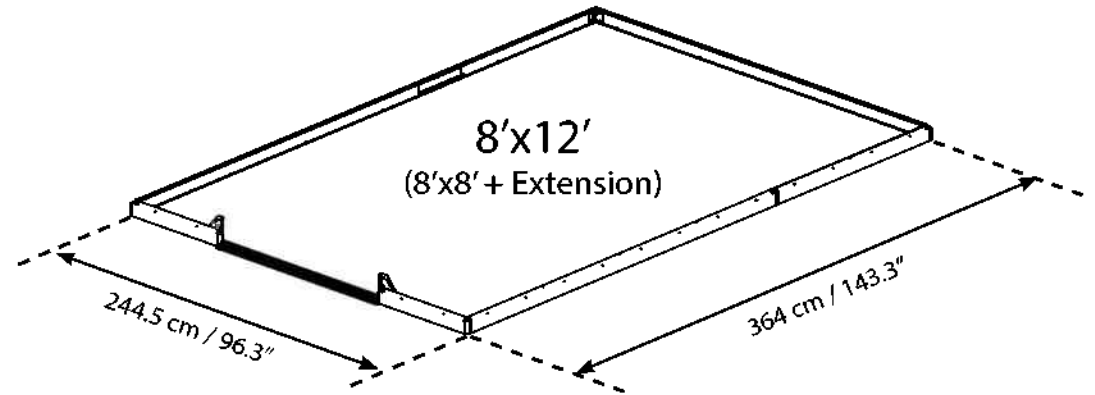
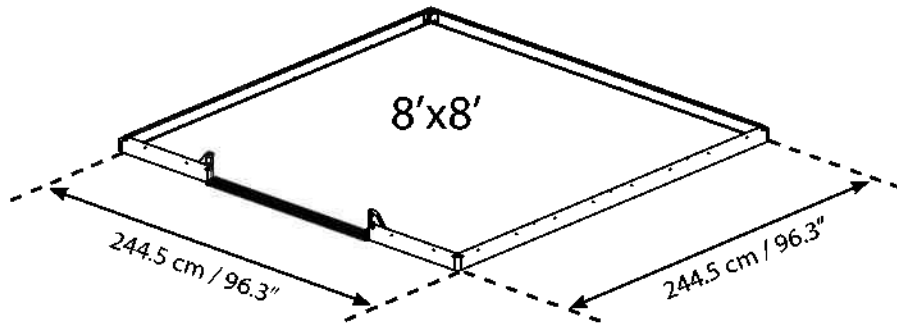
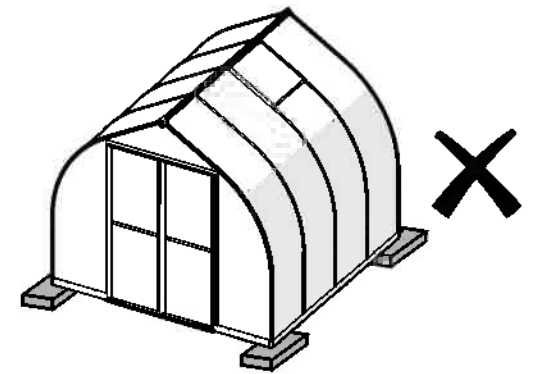
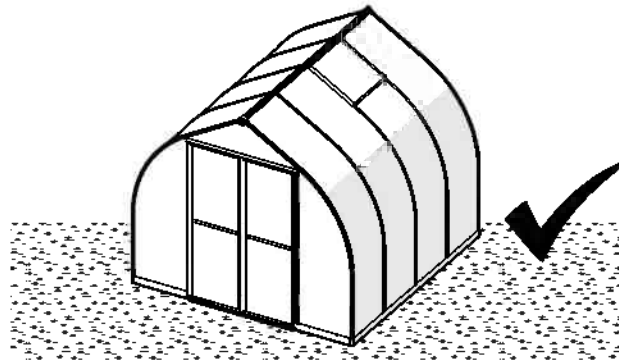
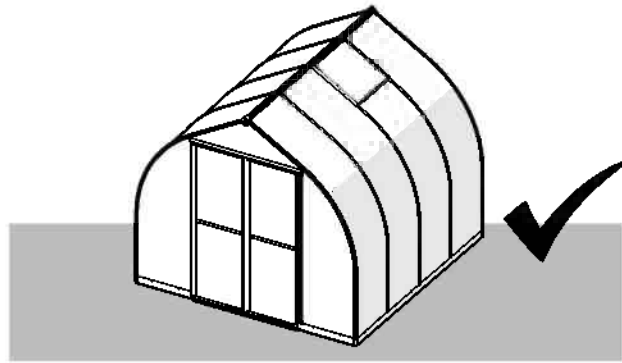

- Rastlinjak trdno pritrdite na ravno površino takoj po zaključenem sestavljanju.
- Sidranje tega proizvoda v tla je bistvenega pomena za njegovo stabilnost in trdnost. To fazo morate opraviti, če želite, da bo vaša garancija veljavna.
- Po končani sestavi zategnite vse vijake



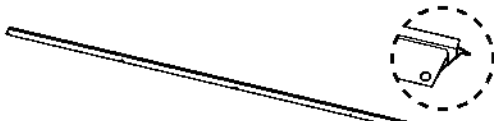





- Vijaki 411 in matice 466 se uporabljajo skozi celoten postopek sestave.
- Vijake 411 je treba postaviti na zunanjo stran, matice 466 pa na notranjo stran rastlinjaka.
- Če ni določeno drugače, vijakov in matic (411 in 466) ne privijte za več kot 2-3 obrata. Ne zategnite jih pred zaključkom sestave panelov. Ti dve ikoni označujeta, če je zategovanje vijakov potrebno ali ne.
- Vendar pa je pri nekaterih korakih morda potrebno začasno zategniti nekaj vijakov, da se prepreči zdrs profila.

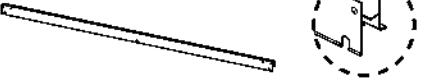









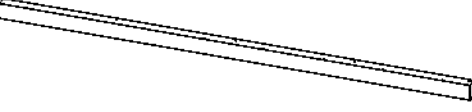

Contents

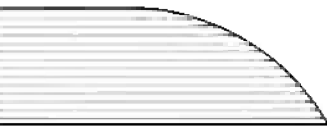
Item		Qty.
8405		6
8414		4
8406		1
8407		1
8452		5
8451		2
8433		3
8400		1
8401		1
8437		1

Item		Qty.
8403		2
8402		2
8404		4
8399		4
989		1
992		2
991		1
8421		1

Item		Qty.
8363		2
7599		3
8420		2
586		1
8417		4
8416		2
8415		2
8418		7
8419		1
8434		2

Contents

Item		Qty.
7065		1
8454		4
8411		4
8710		4

99		1
22		2
7009		2 (+1)

318		8
3017		2
7271		1

8254		1
8255		1
7908		2
7602		4

462		4
464		8
463		4
422		16 (+2)
465		16 (+2)

7083		1
7084		1
7085		1
7086		1
7088		1
423		1

8230		2
7871		2
7870		2

Item		Qty.
411		87 (+8)
8192		4
466		81 (+8)
412		10
4008		20 (+2)
7335		24 (+2)
450		6
7442		20 (+2)

7066		2
T001		1

Contents Extension Kit

Item	Qty.	Item	Qty.	Item	Qty.
7597	2	989	1	411	31 (+3)
8405	4	991	1	466	31 (+3)
8429	1	992	2	4008	4
8430	1	8421	1	4045	16 (+2)
8453	4	7039	1	7442	16
586	1	7931	1	8447	2
8418	3	8455	4	7601	2
8419	1	8710	2	99	1
		3017	2	22	2
				7009	2 (+1)

1

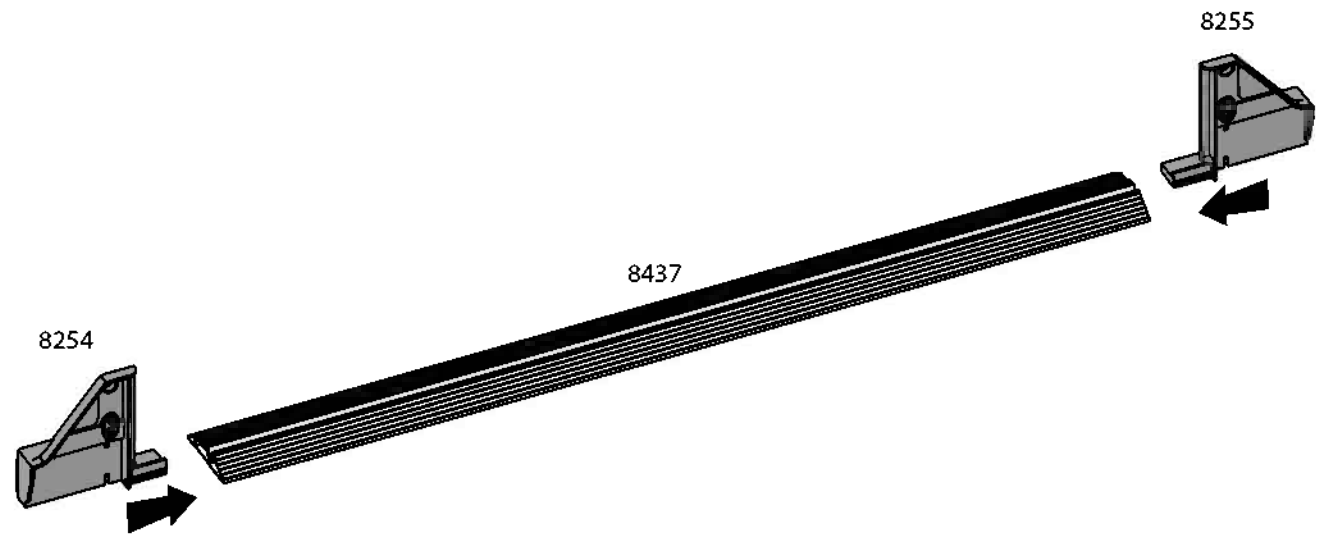
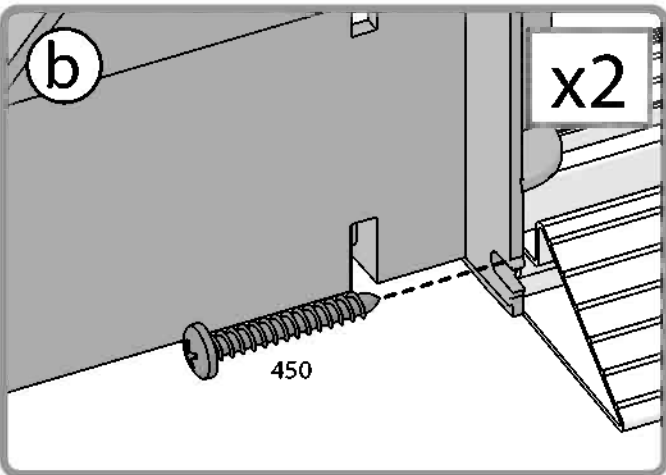
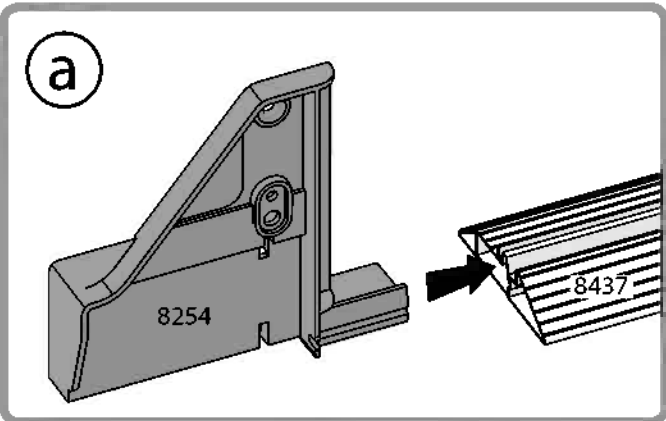
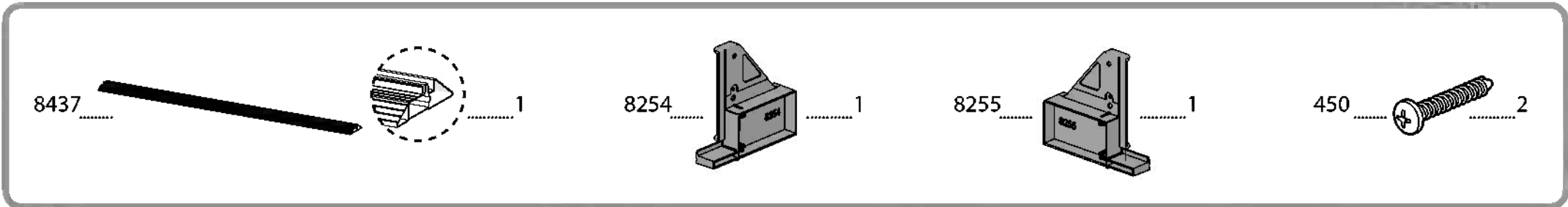

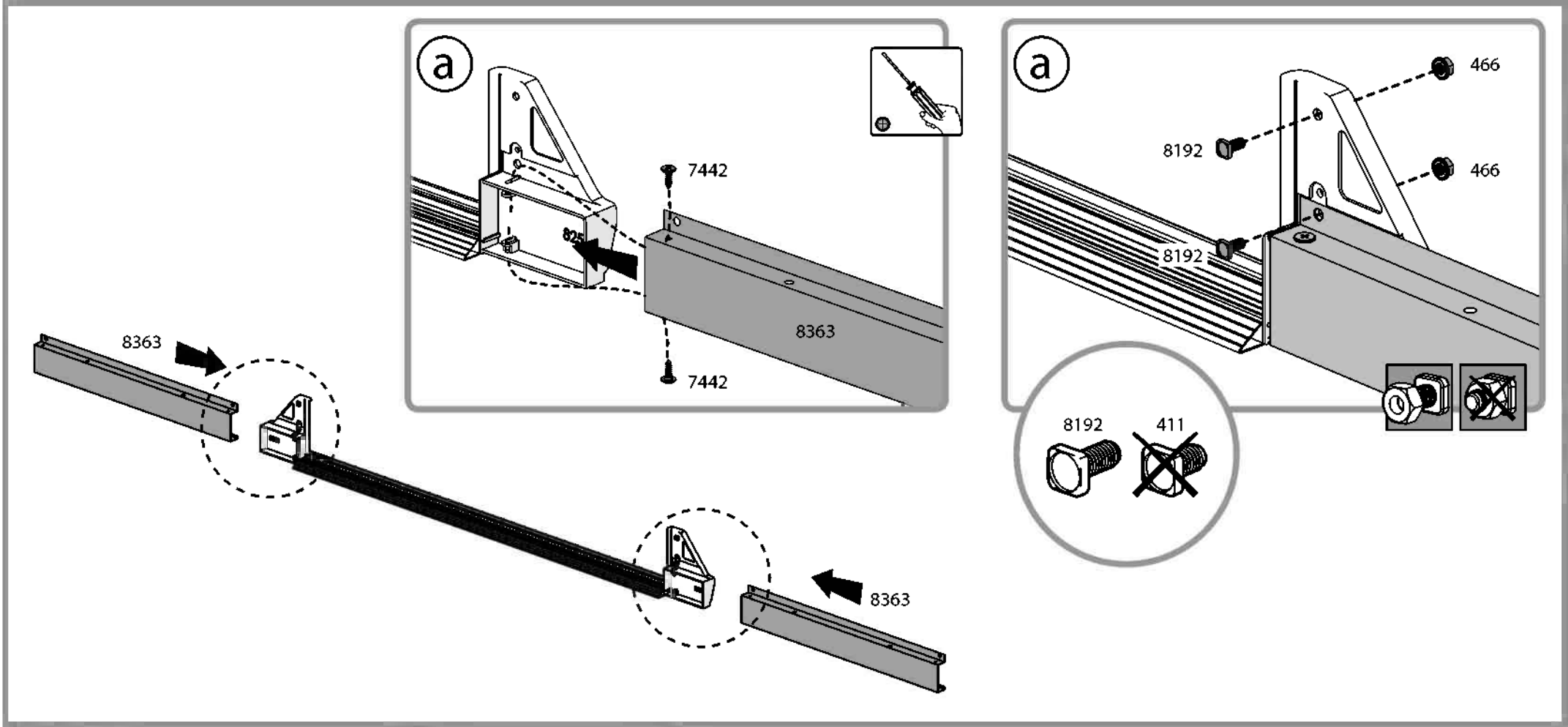
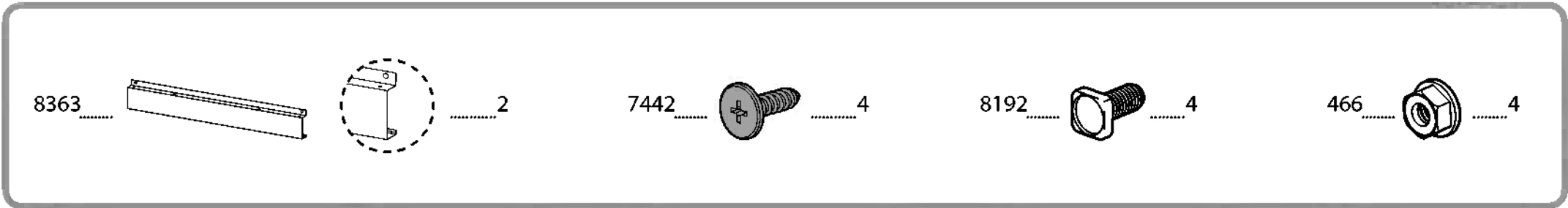

3



For Extension Kit Only



8447

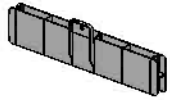

..... 2

7599



..... 2

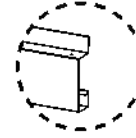

..... 2

7442

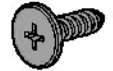

..... 16

7601

OR



..... 2

7597

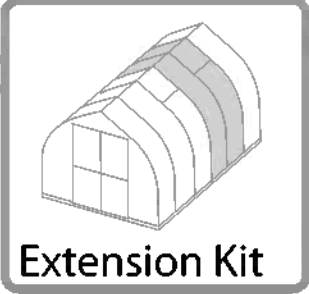

x2

8'x12'
(8'x8' + Extension)

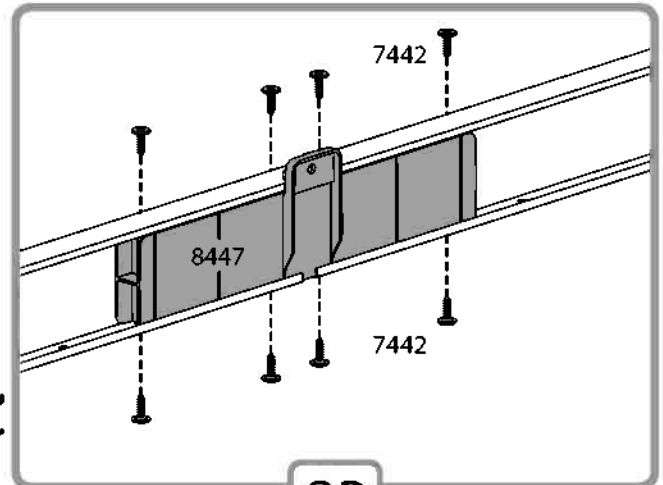
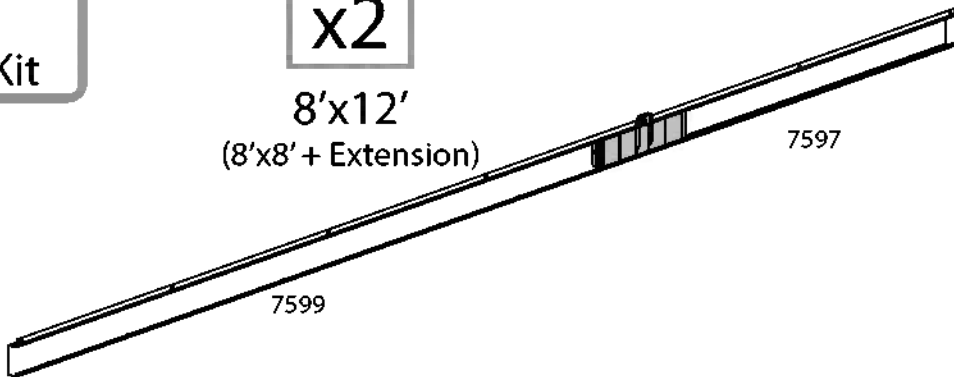

OR

8'x16'
(8'x8' + 2 Extensions)

x2

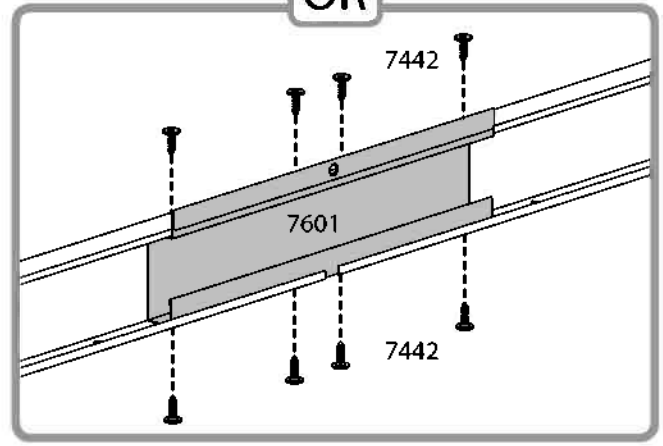
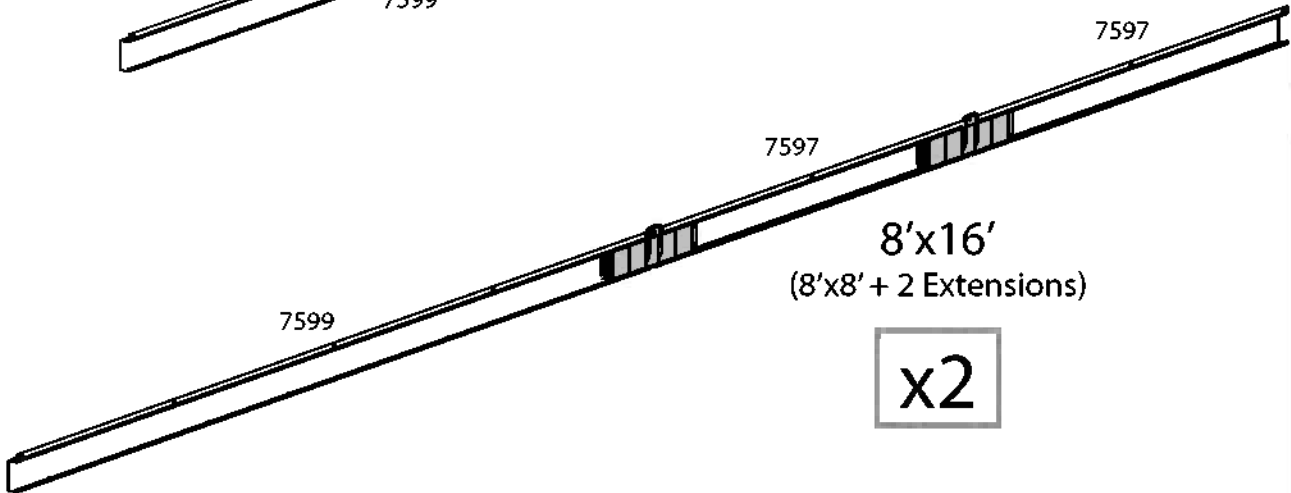

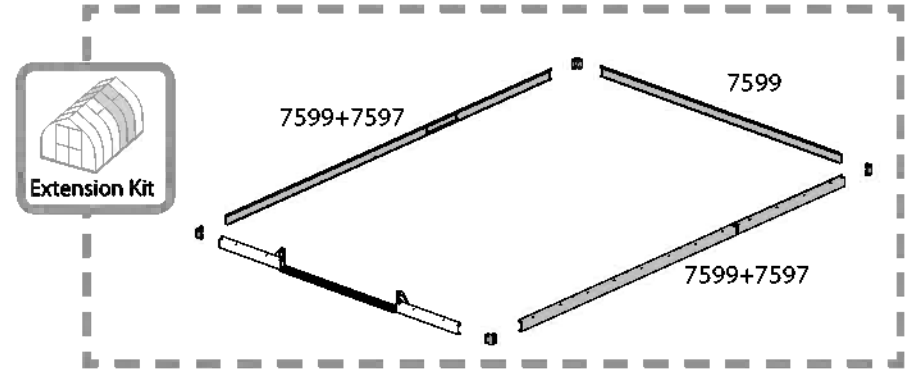
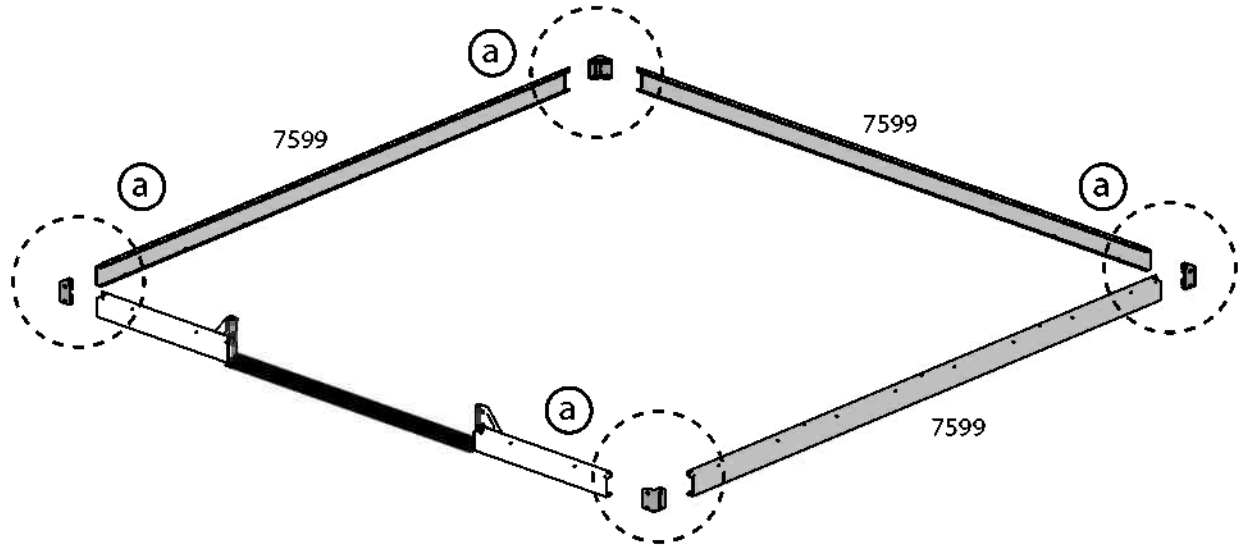
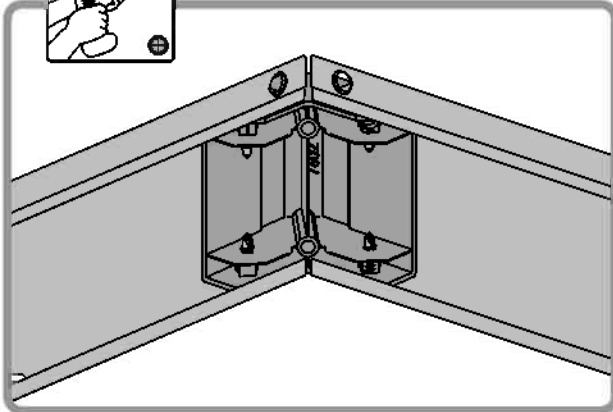
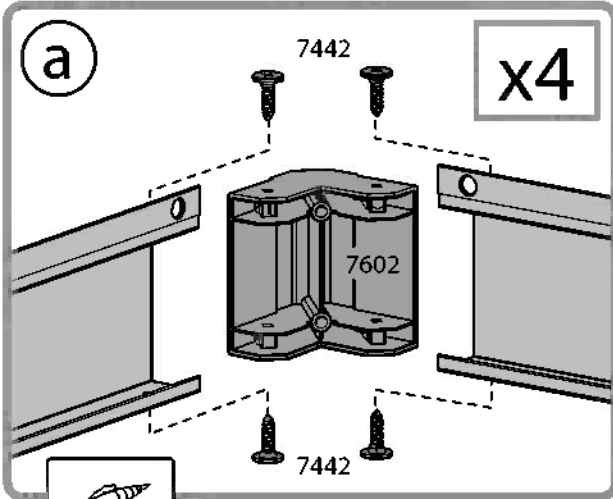
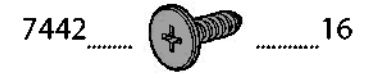
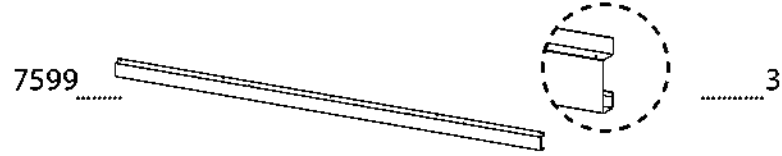
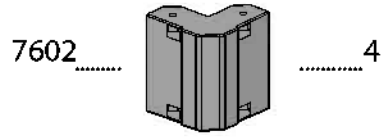

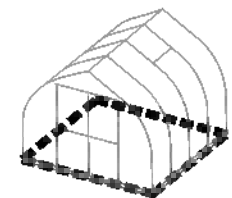

411 9



466 9



411 +4

466 +4

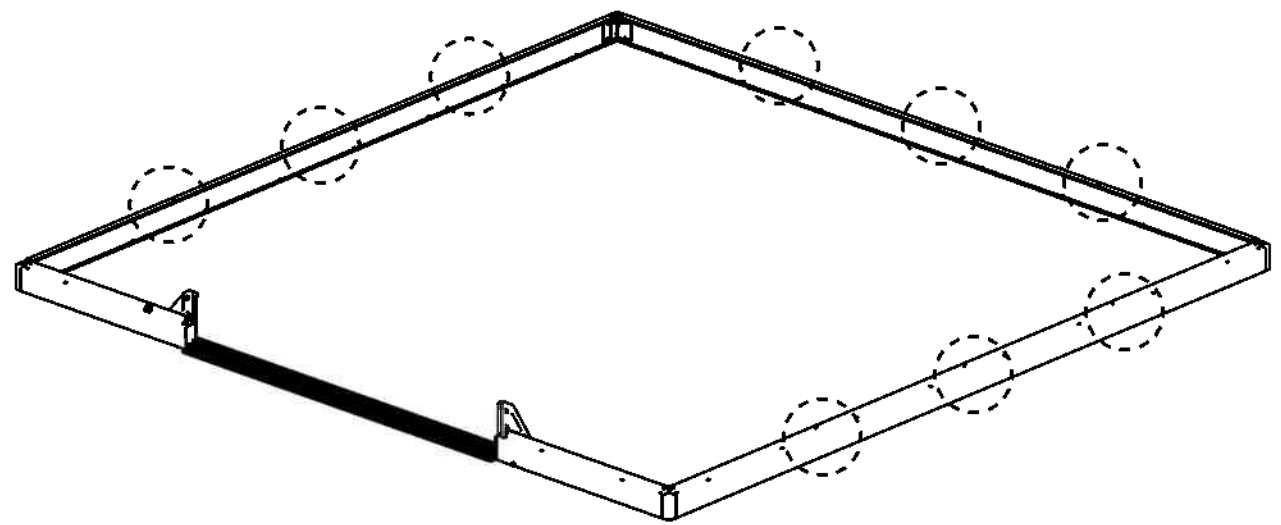
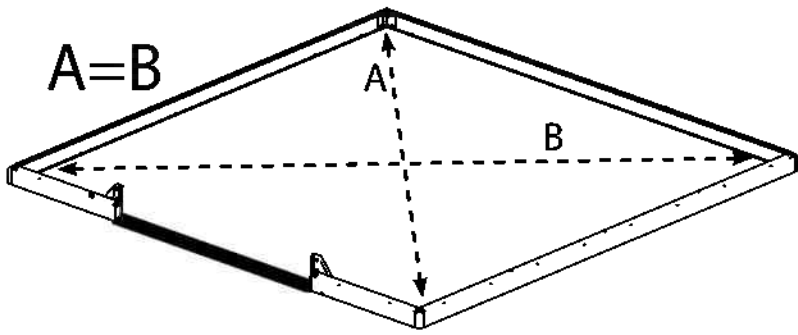

466

411

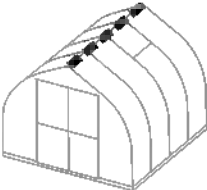

8407.....   1

411.....  10

466.....  10

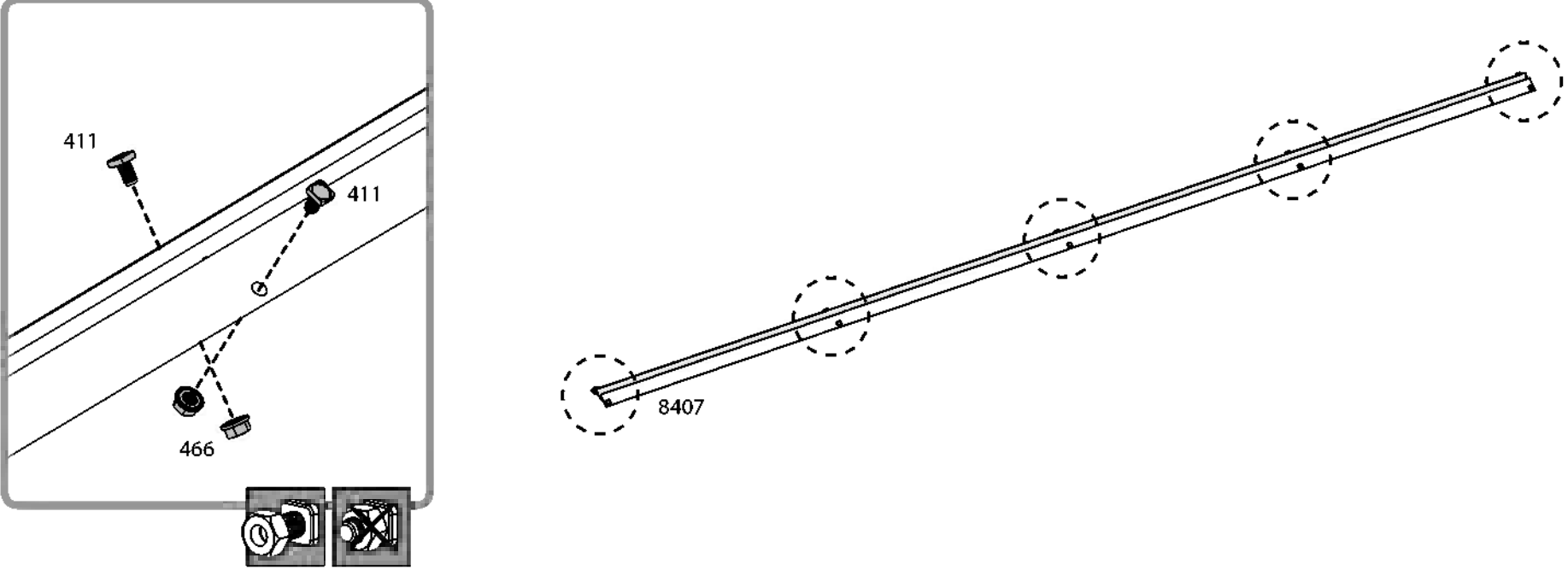

411

411

466

8407

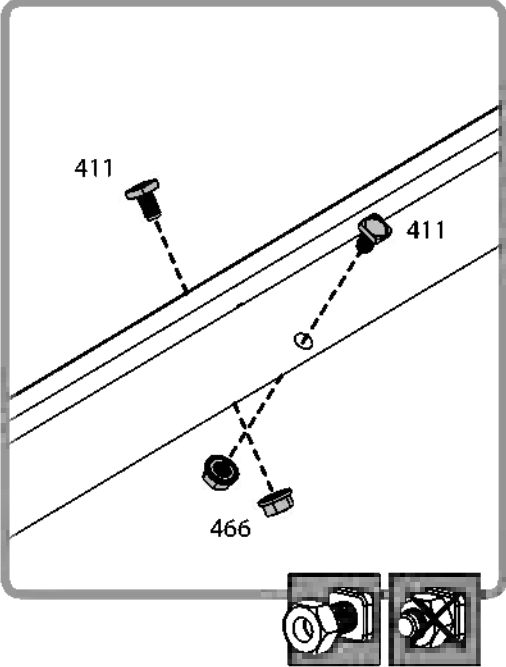

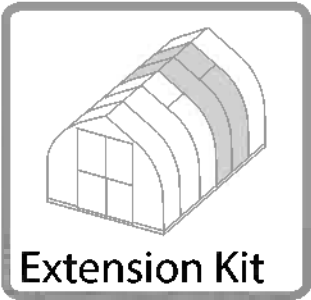
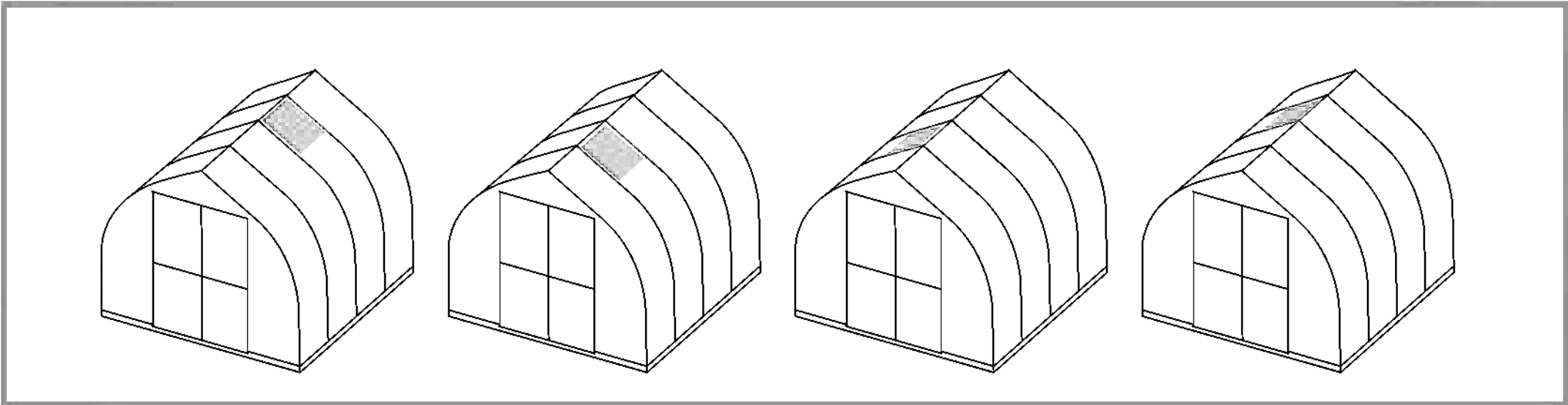
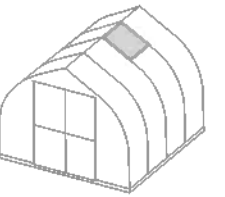

Extension Kit

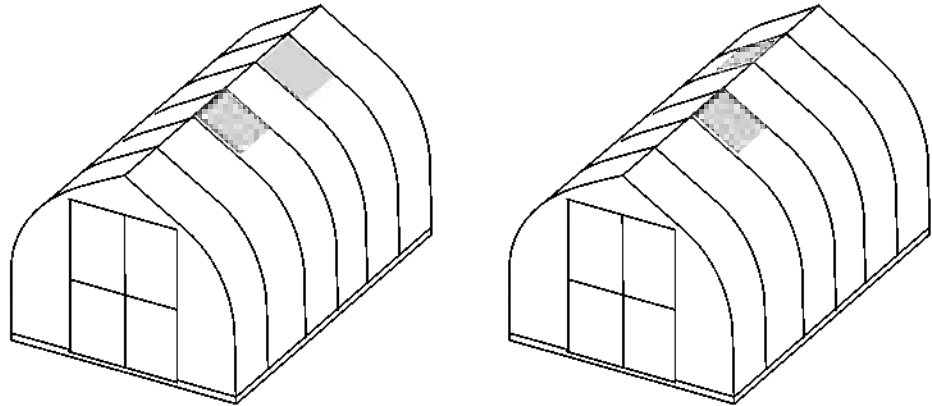

8'x12'
(8'x8' + Extension)

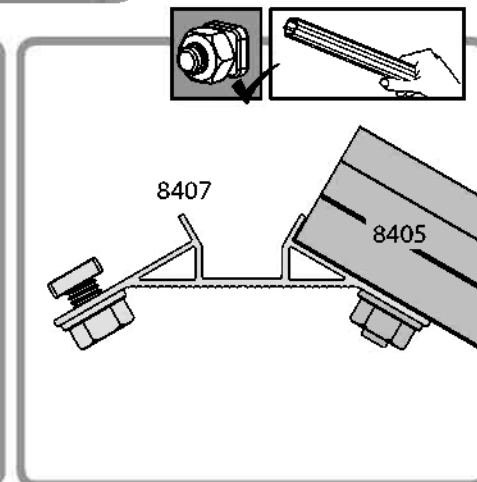
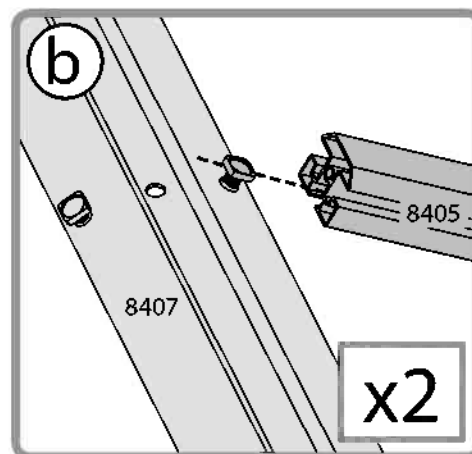
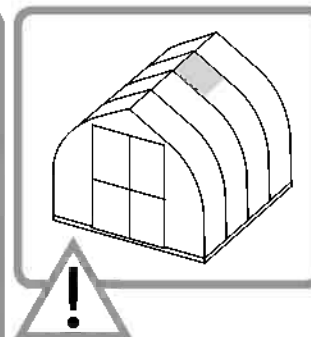
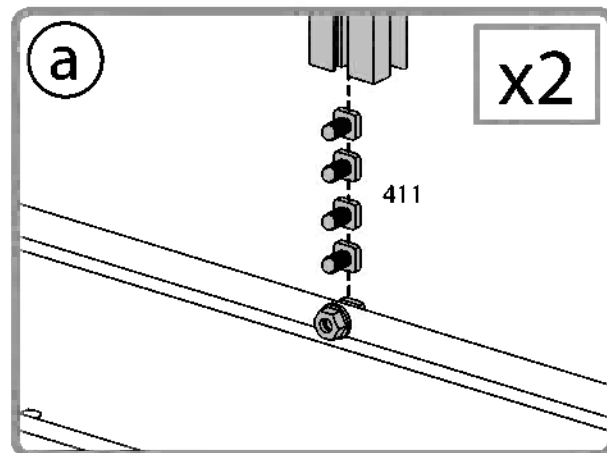
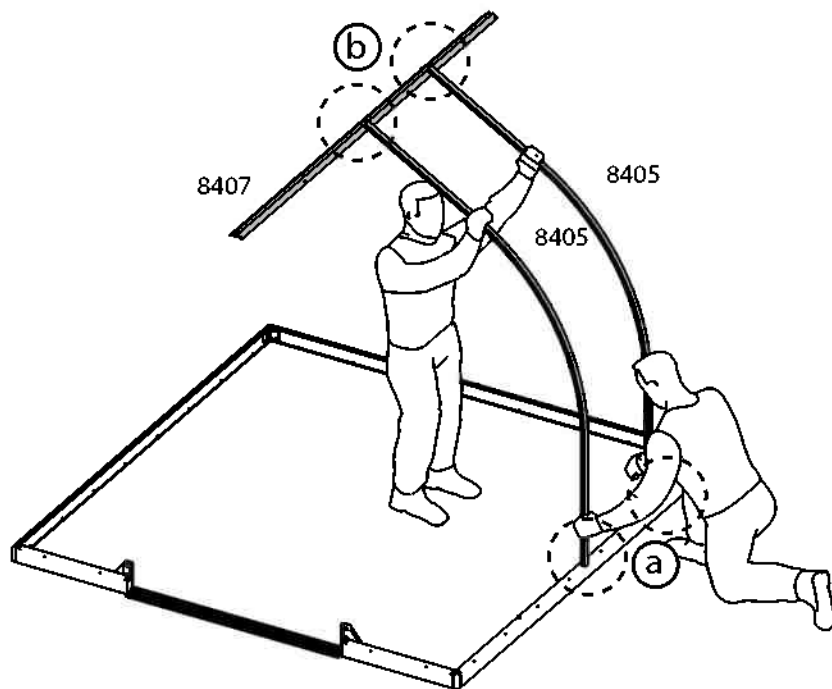
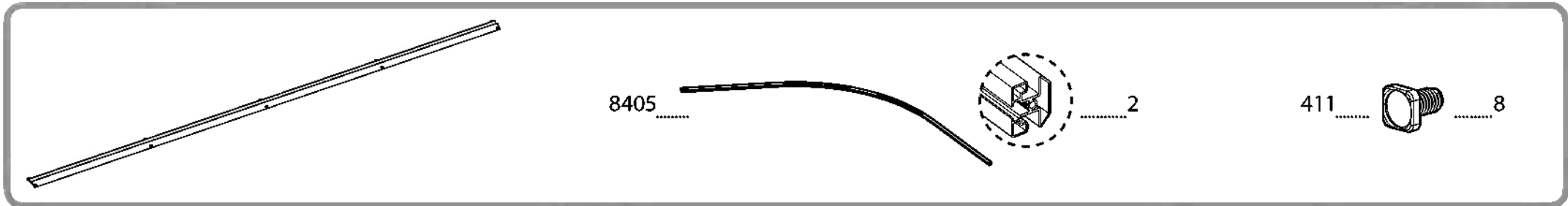
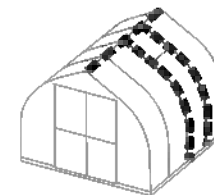

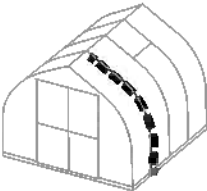

8405

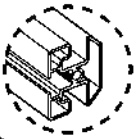

1

411



2

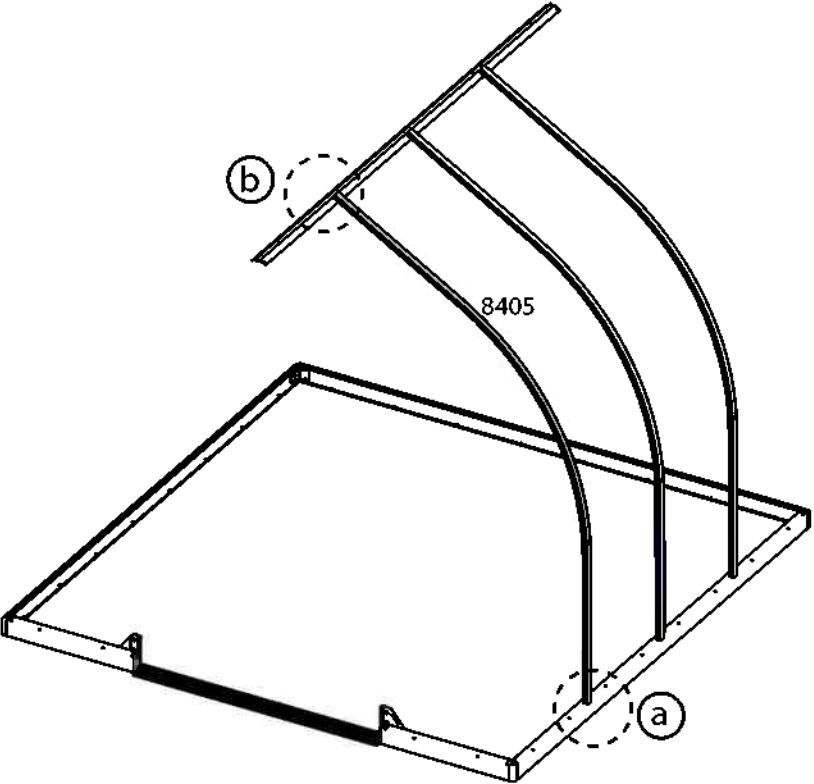

a

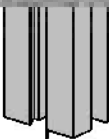

411

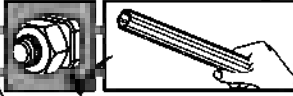

b

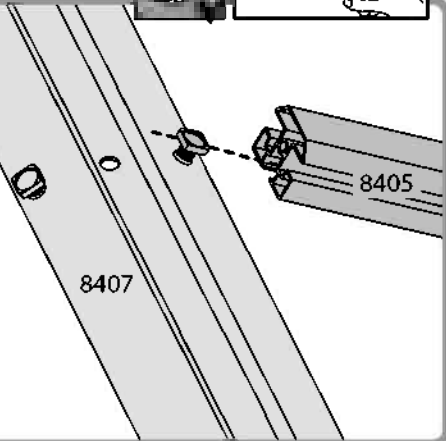

8407

8405

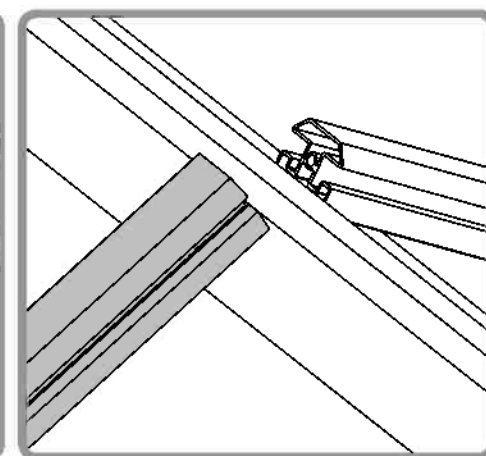
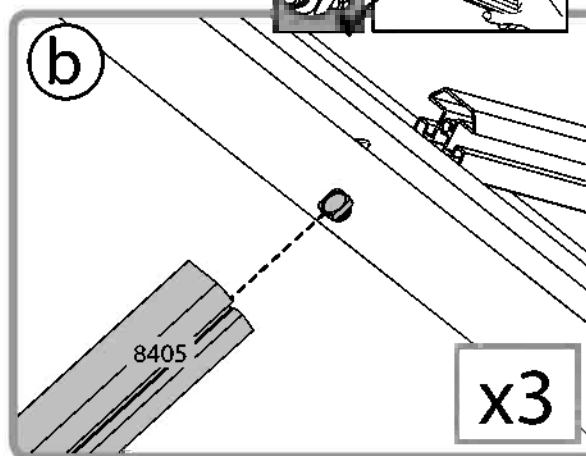
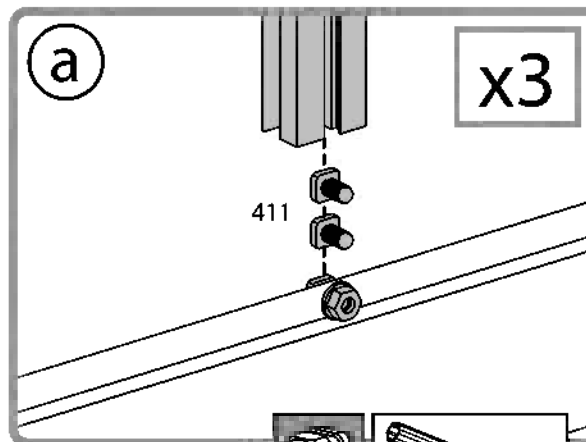
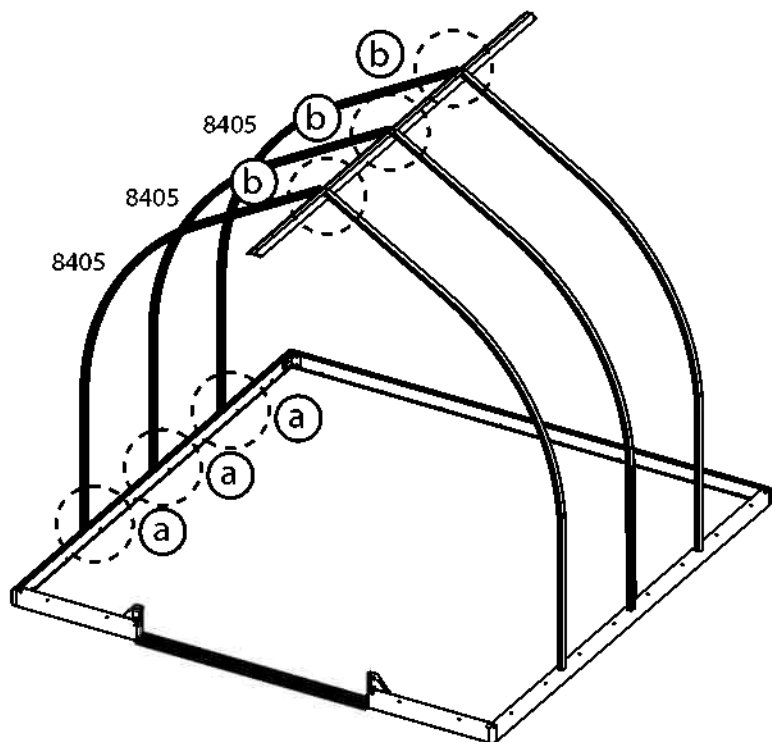
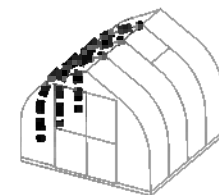

11 For Extension Kit Only

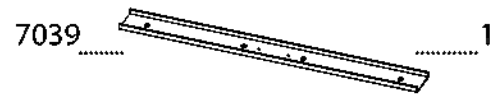
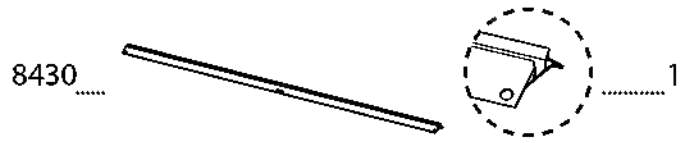
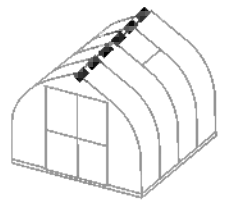

- 411 8
- 466 8

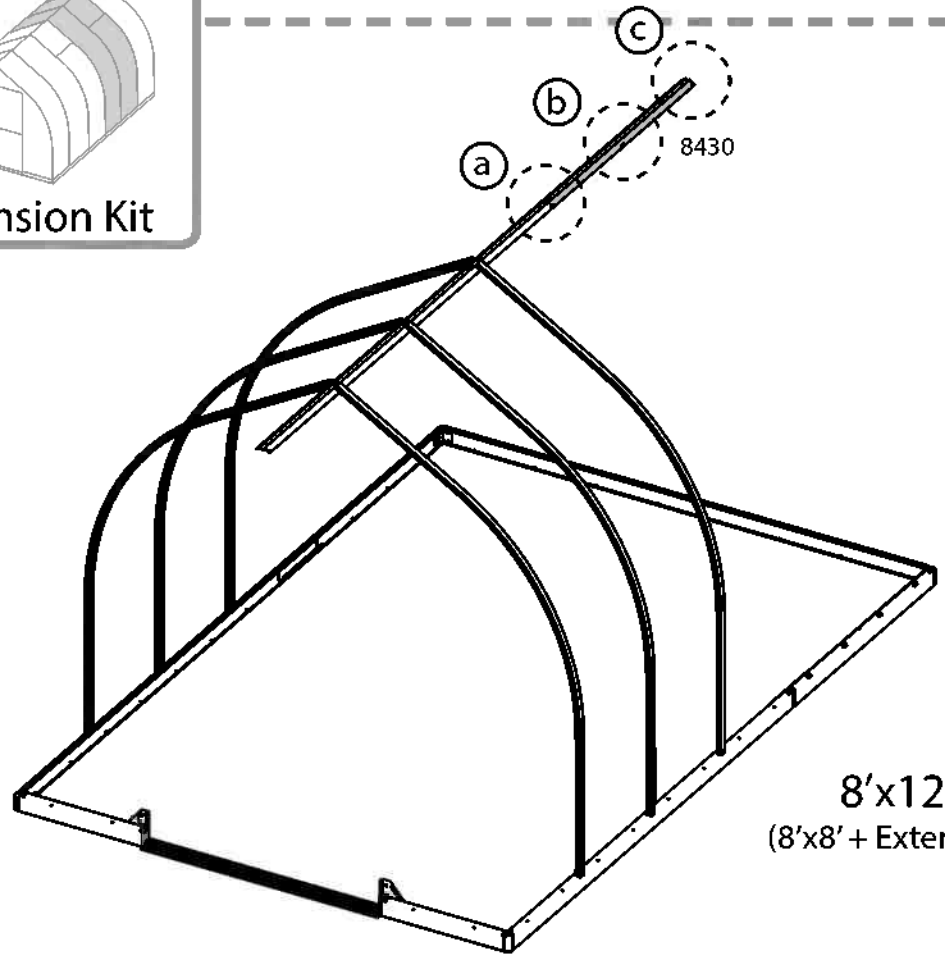
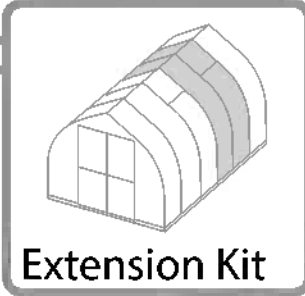

8'x12'
(8'x8' + Extension)

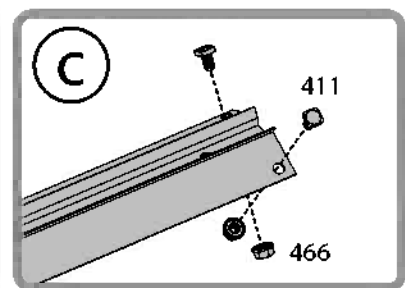
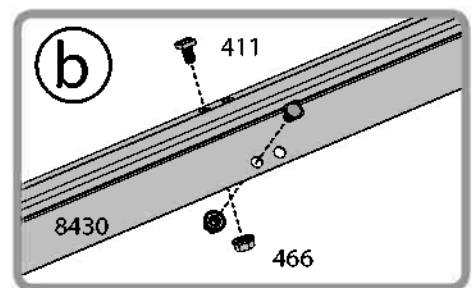
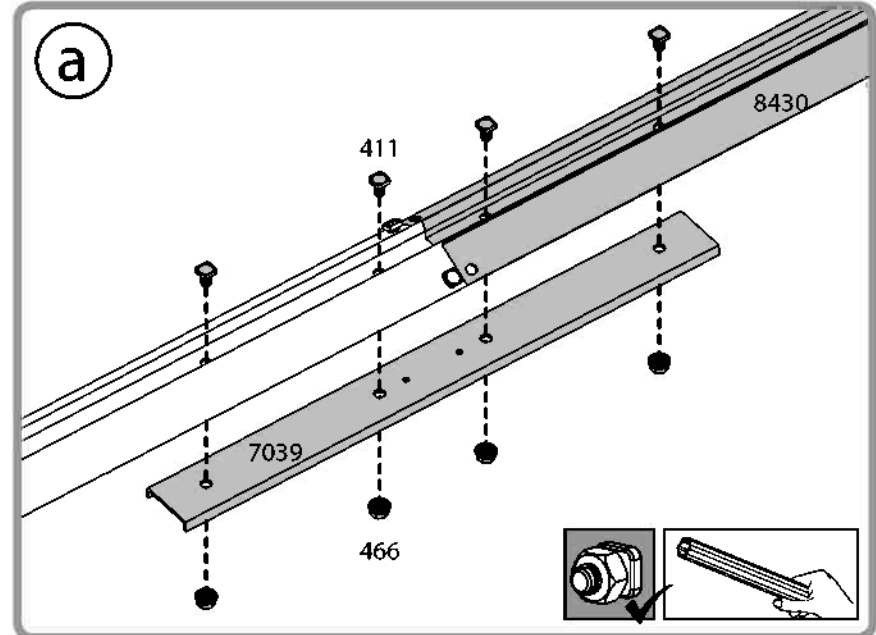

12 For Extension Kit Only

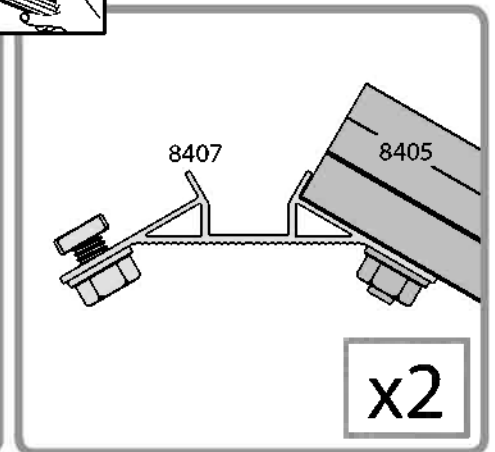
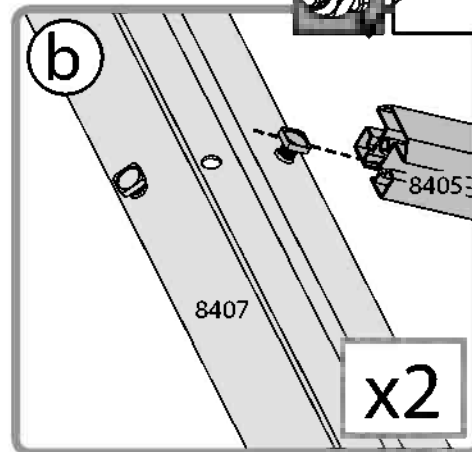
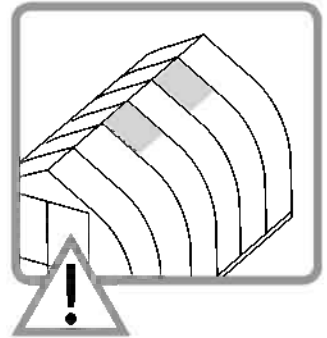
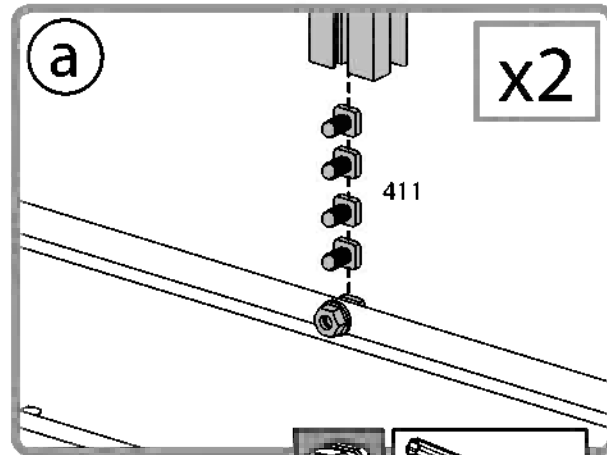
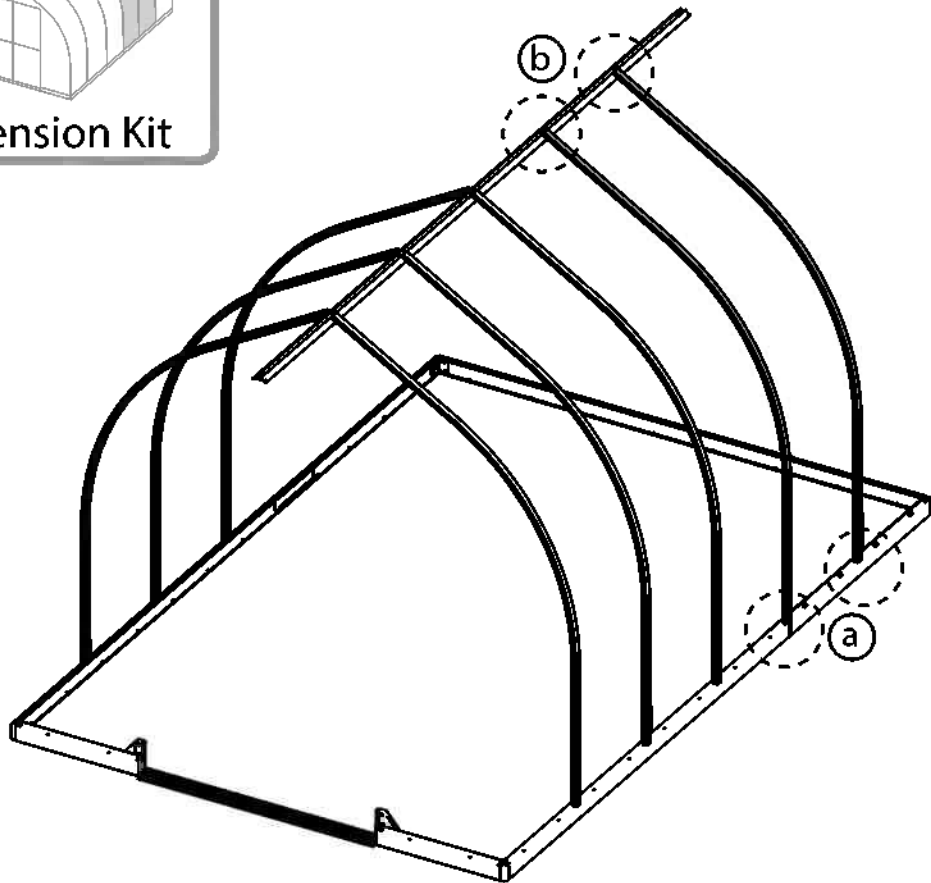
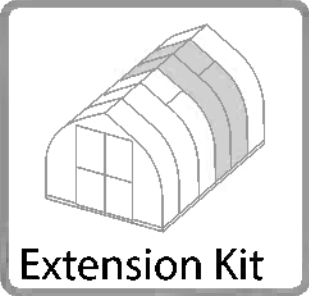
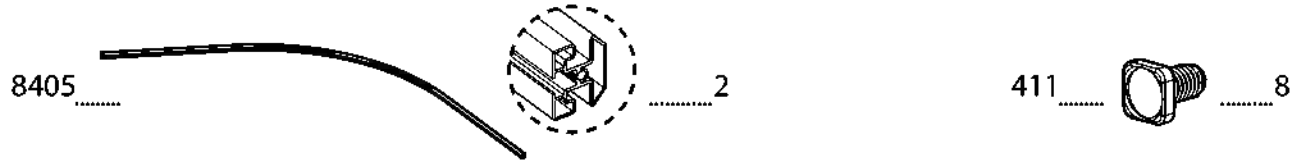
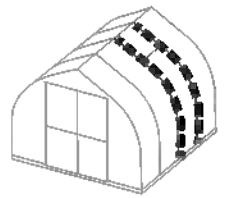

13 For Extension Kit Only

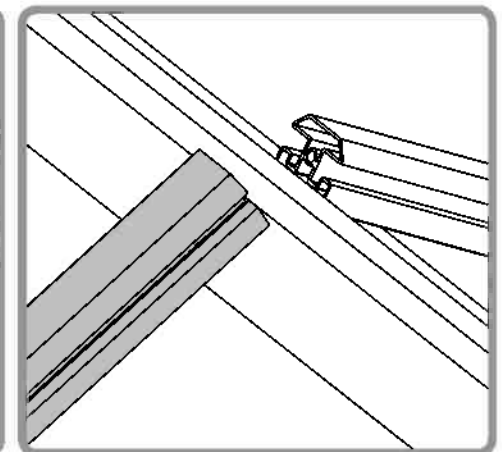
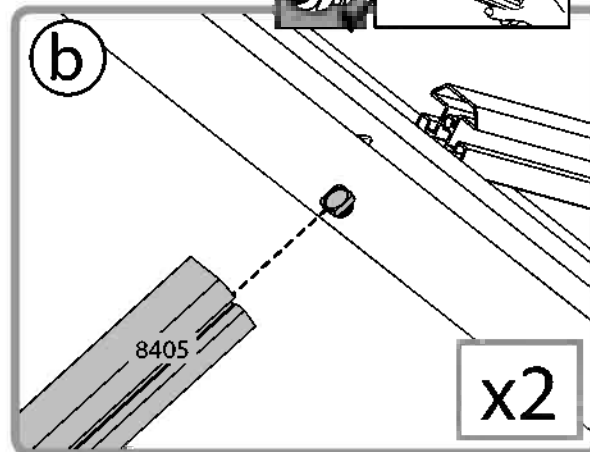
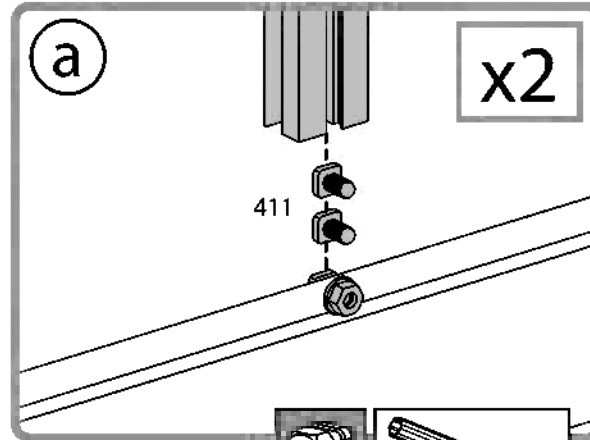
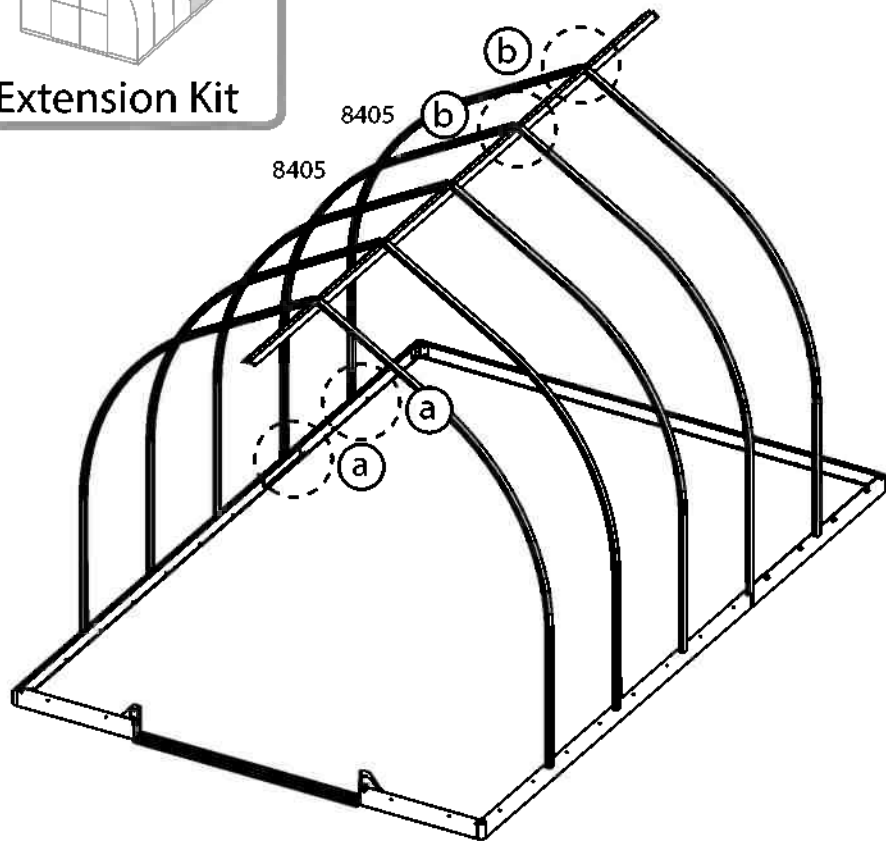
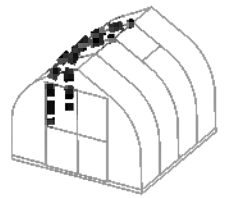

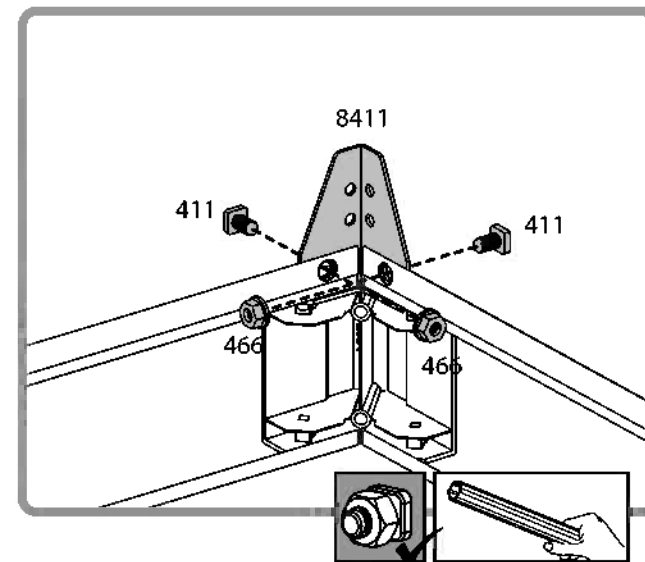
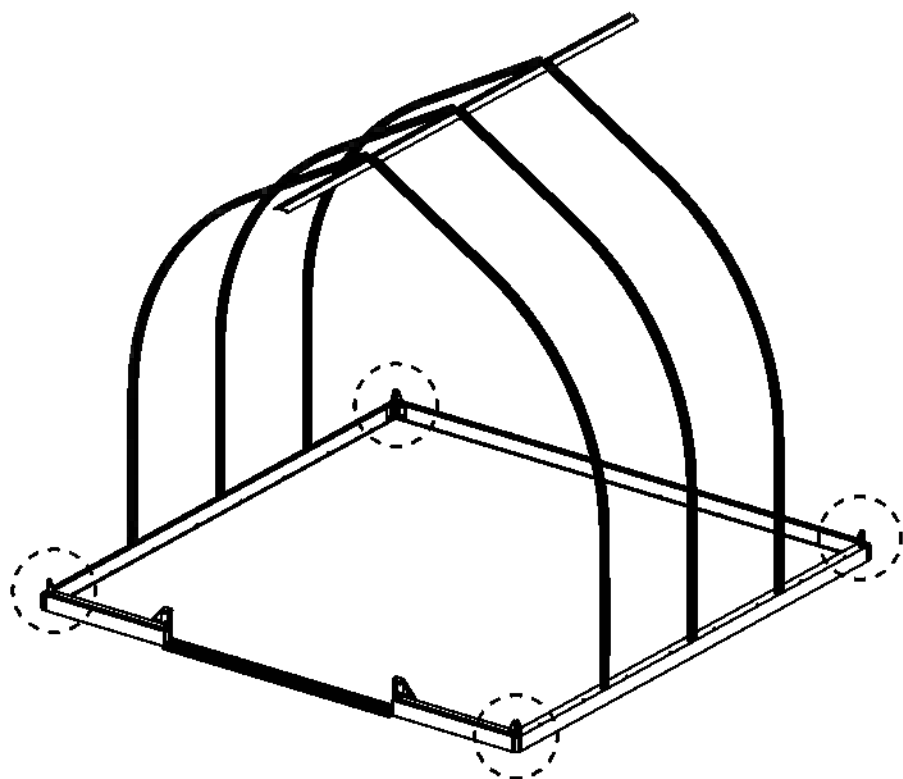
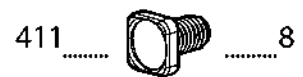
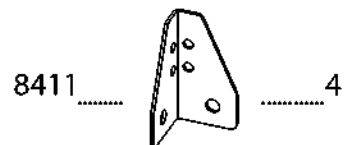

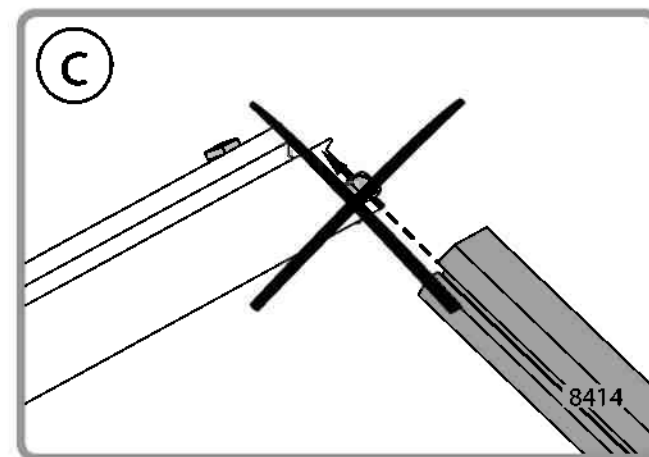
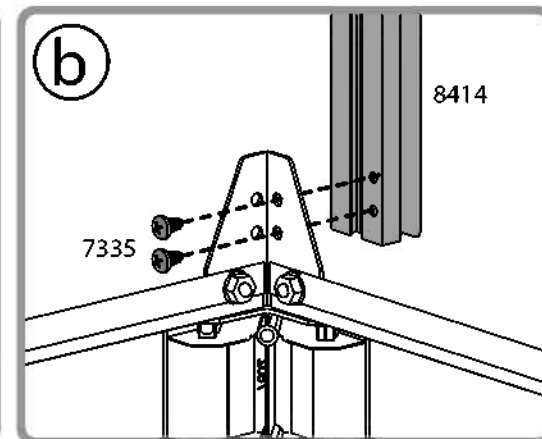
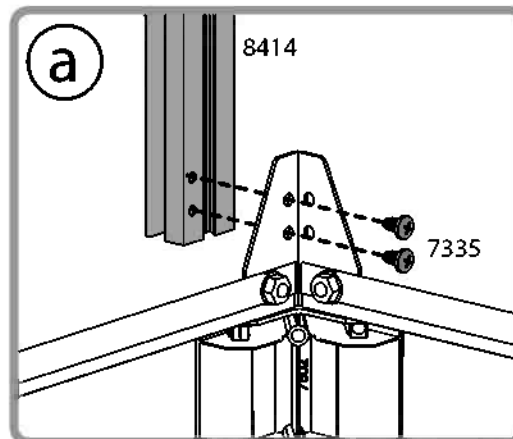
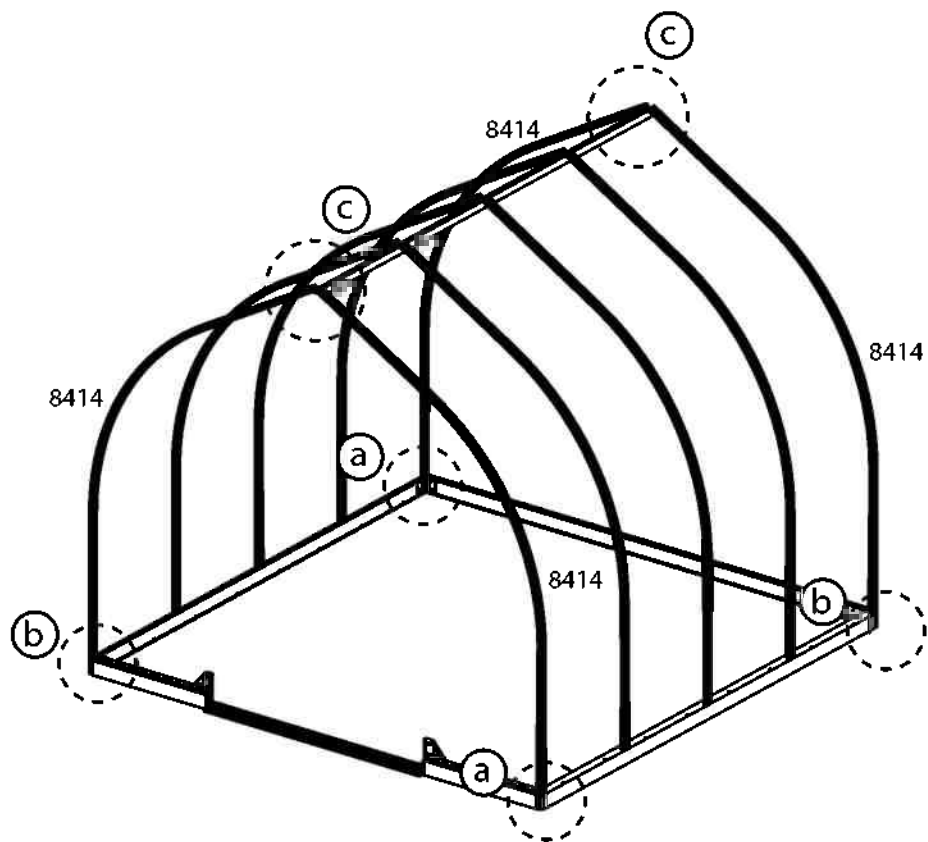
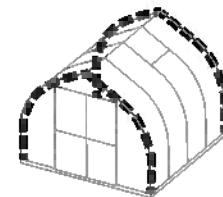

16 For Extension Kit Only

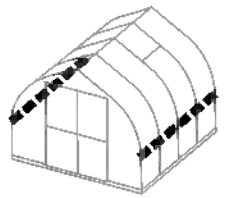

- 8452 2
- 8453 2
- 8455 2
- 4045 8



Extension Kit

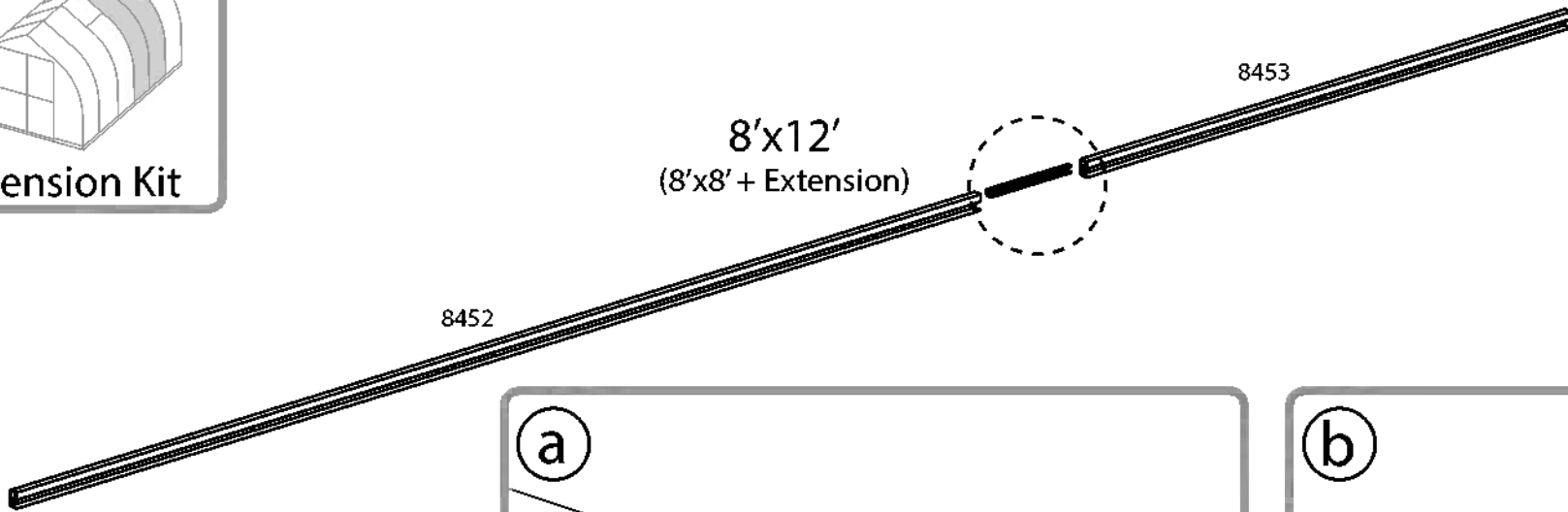

x2

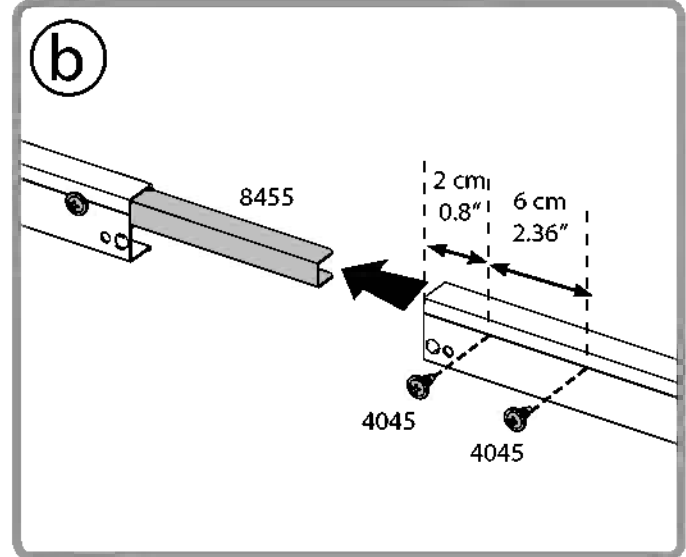
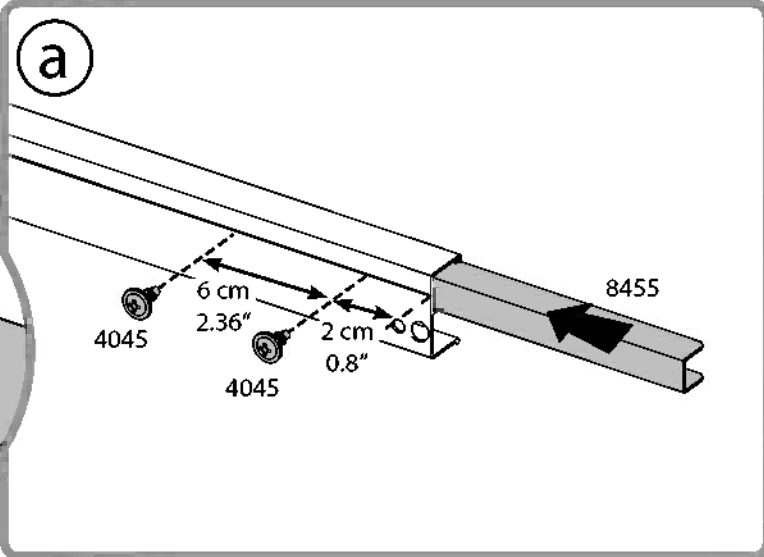
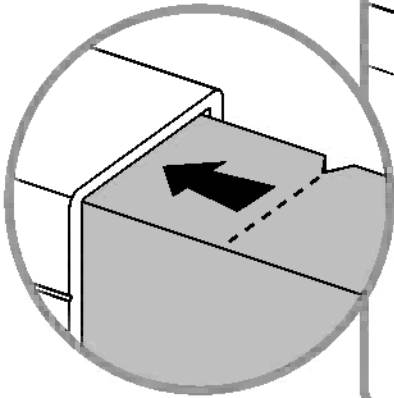

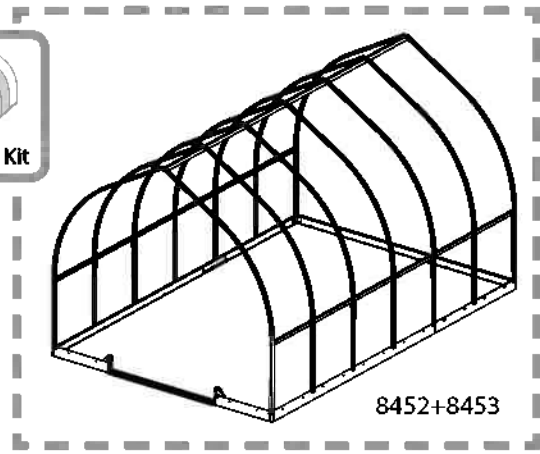
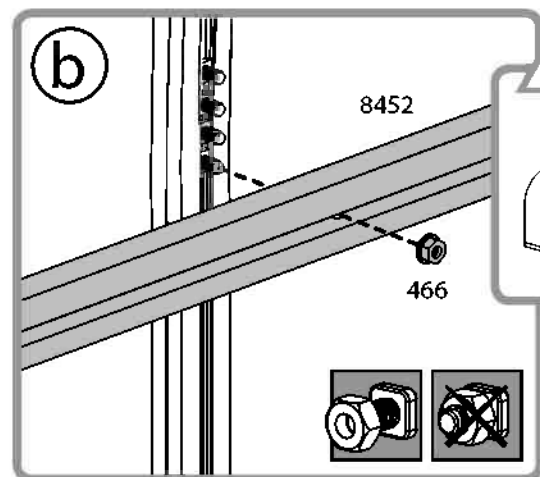
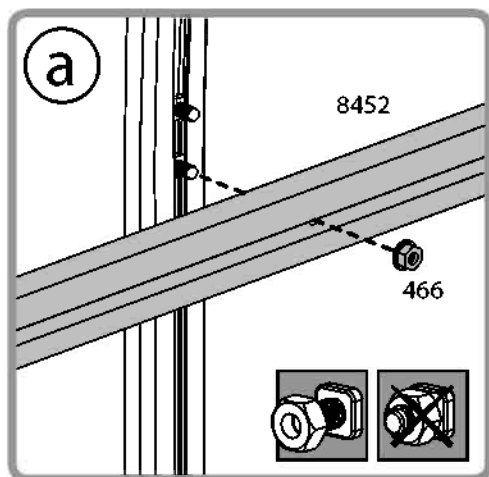
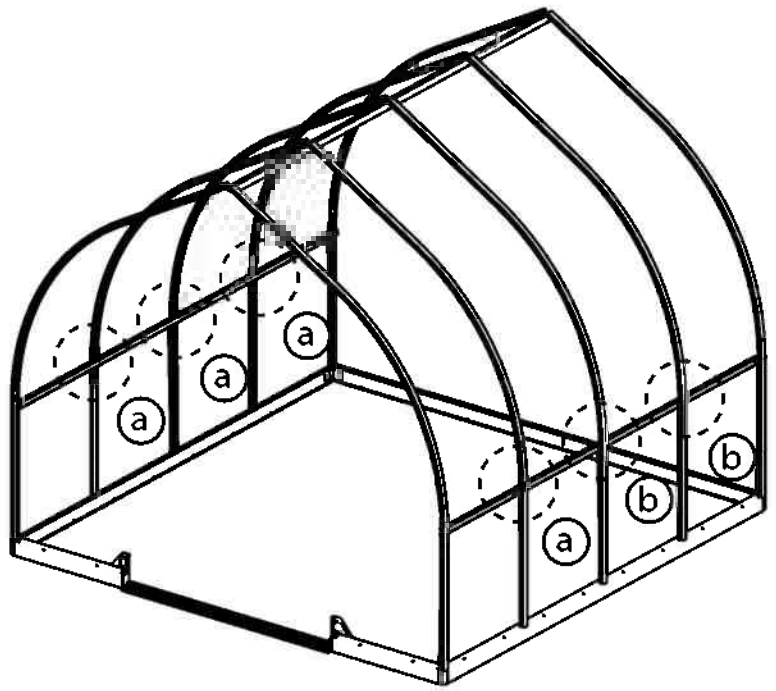
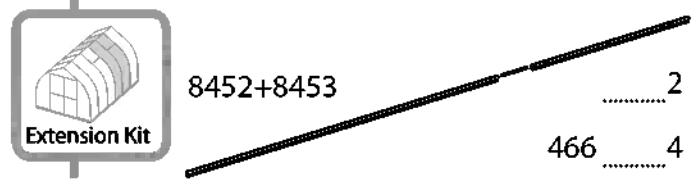
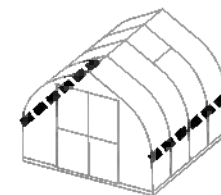

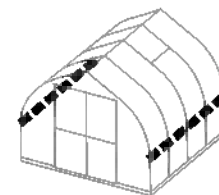

7335  4

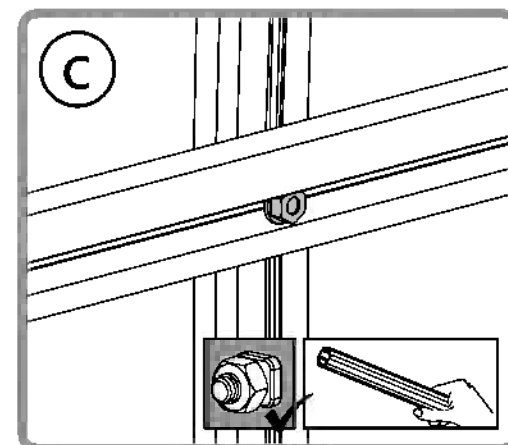
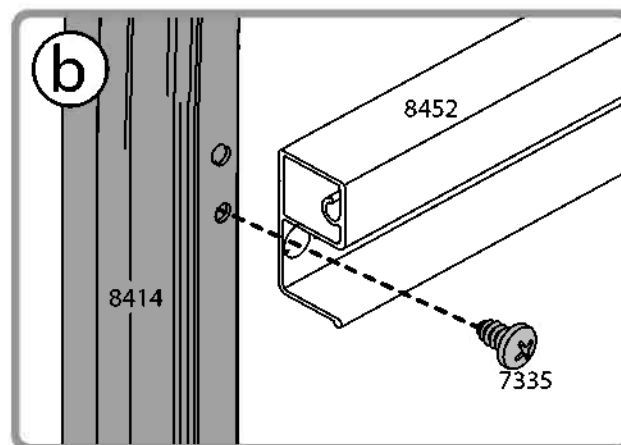
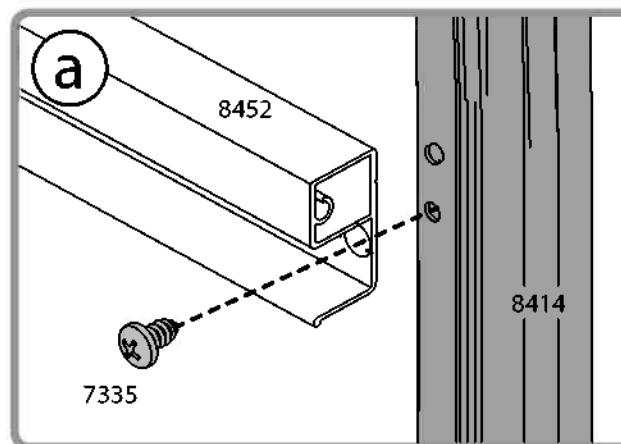
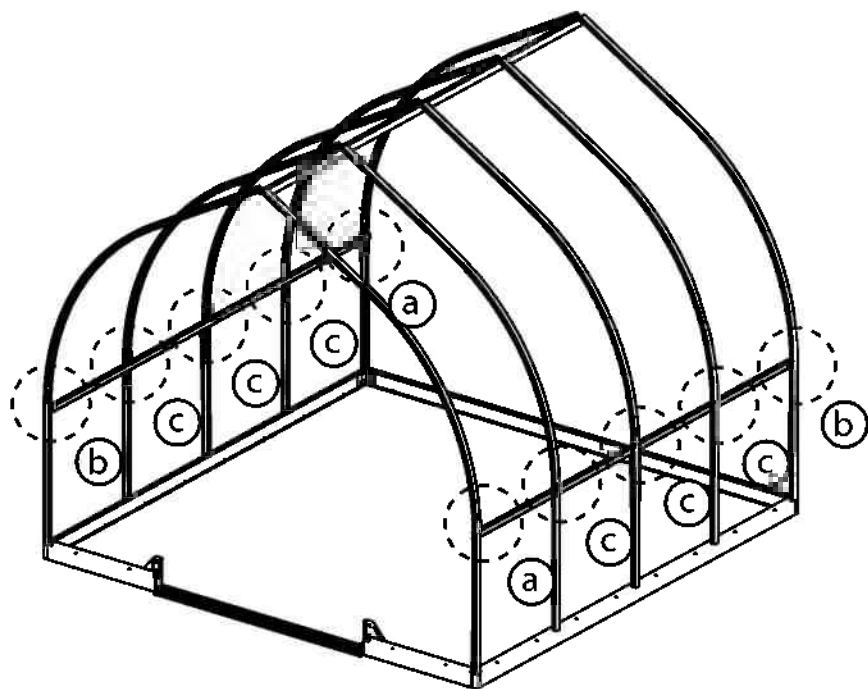

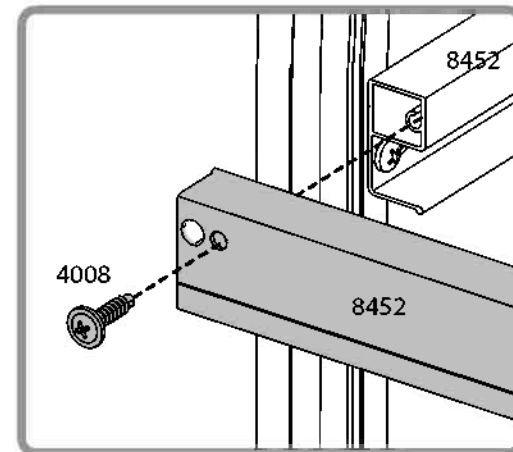
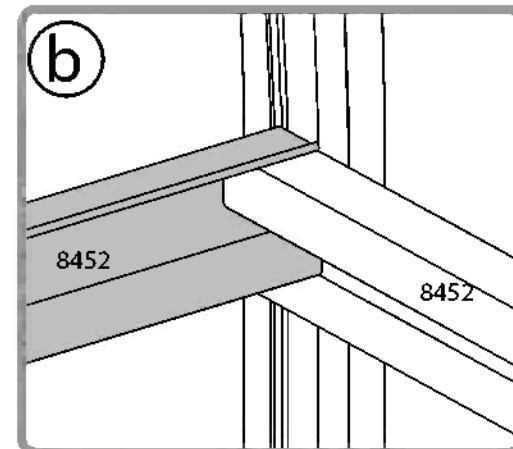
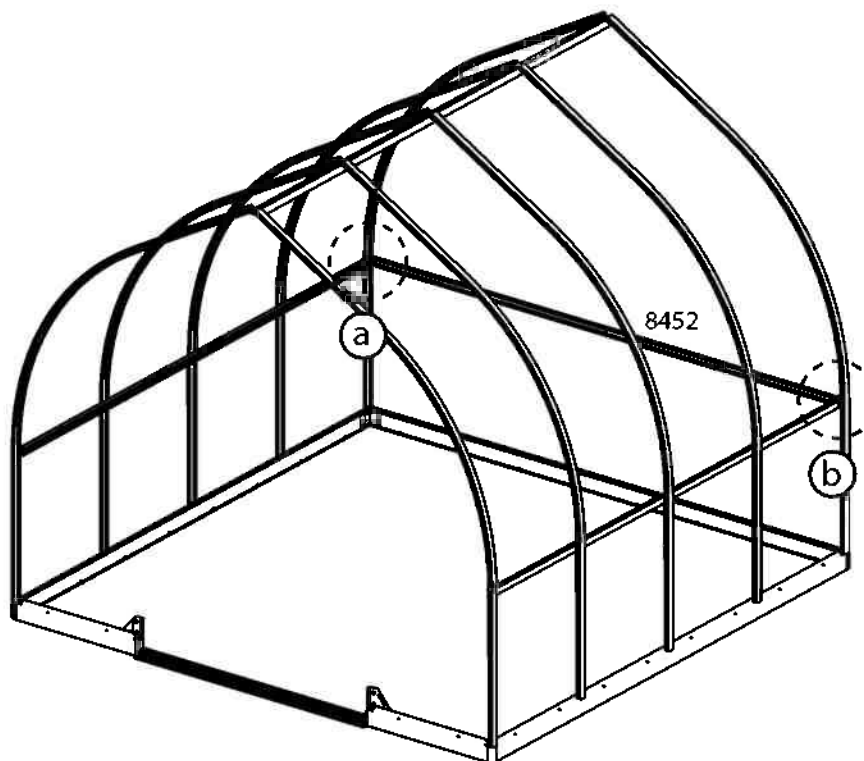
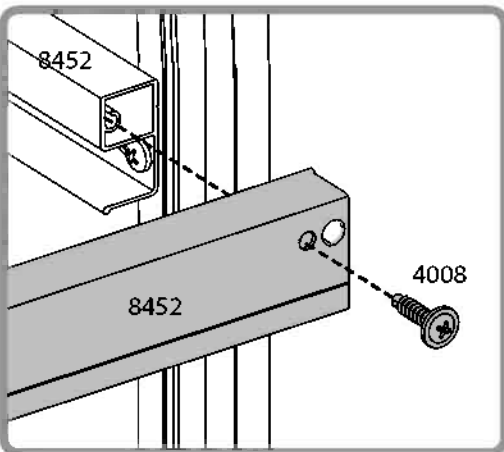
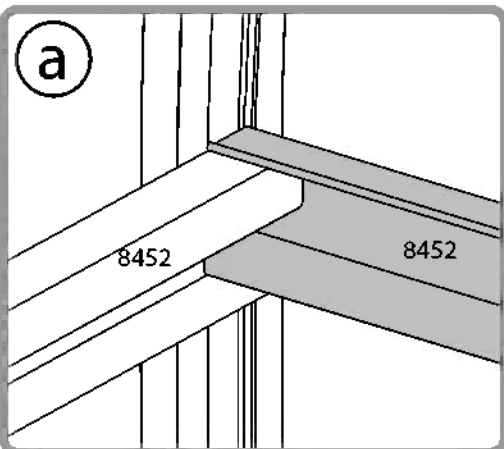
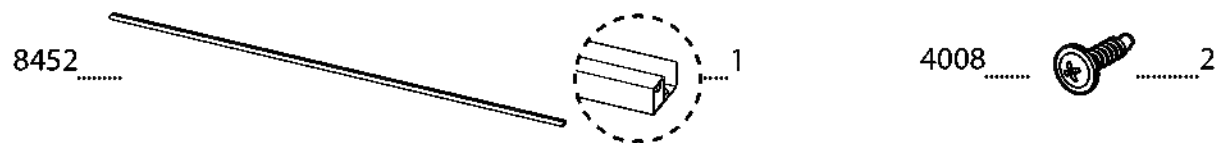
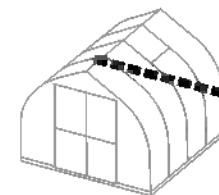

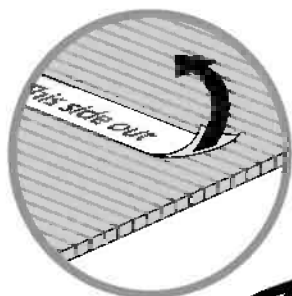
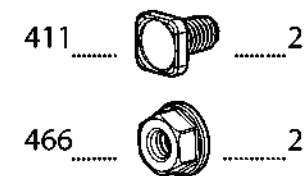
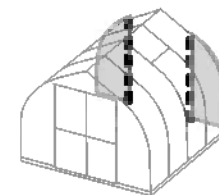

This side out

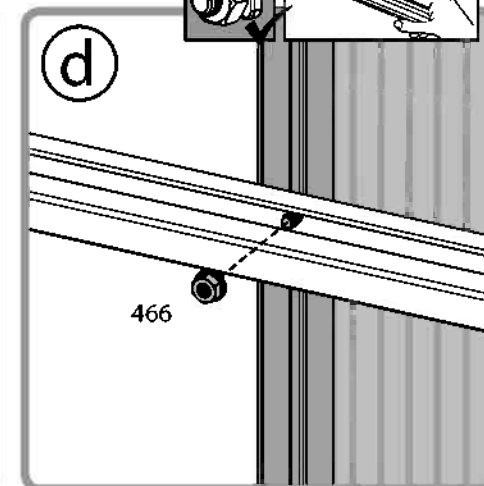
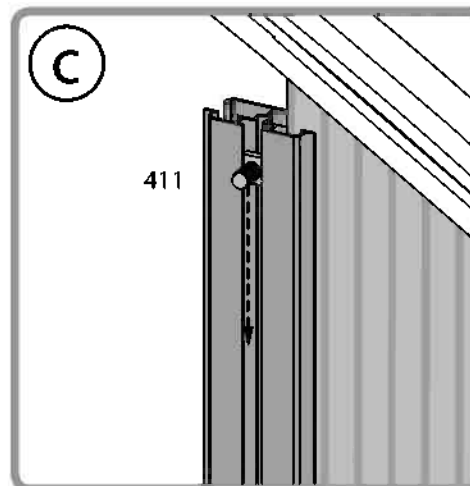
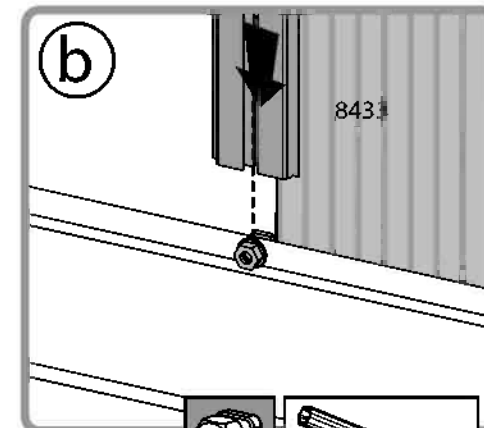
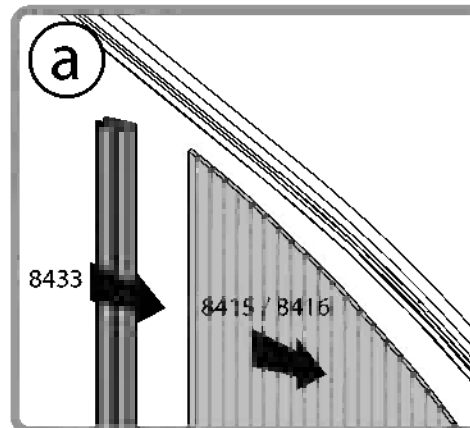
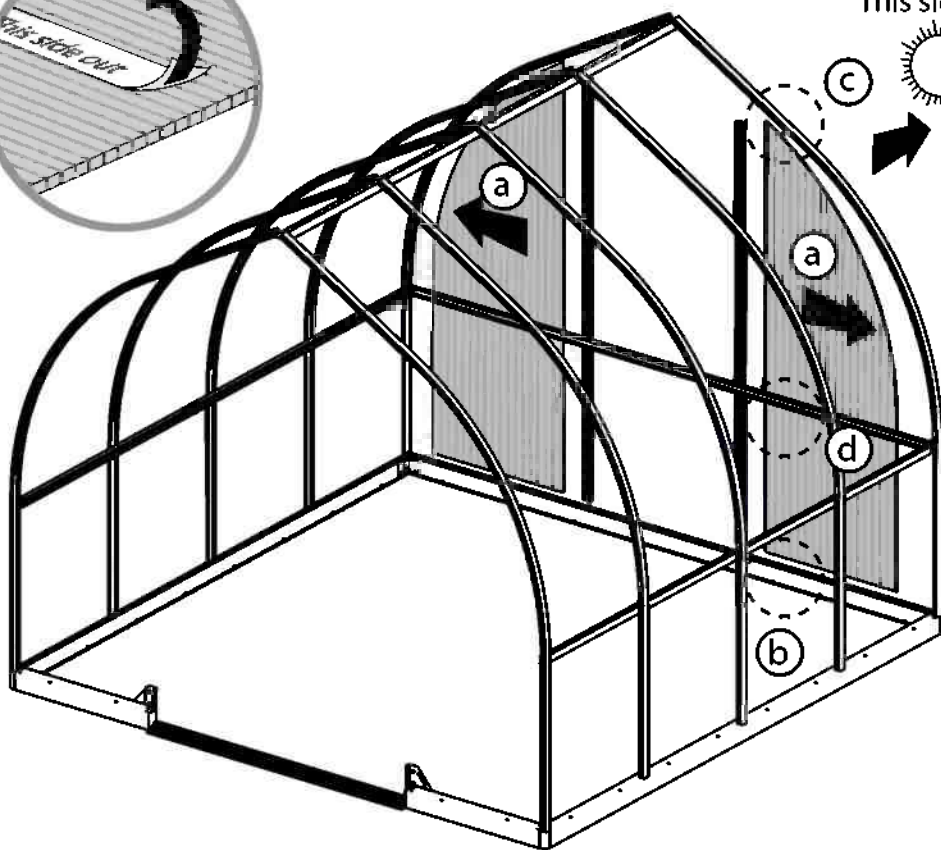

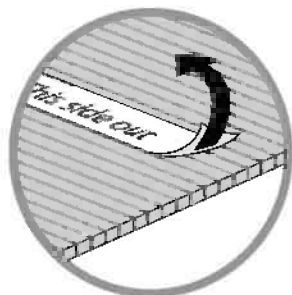
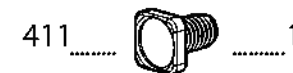
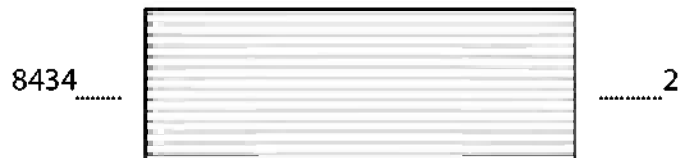
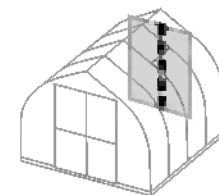

This side out

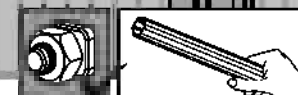
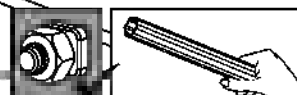
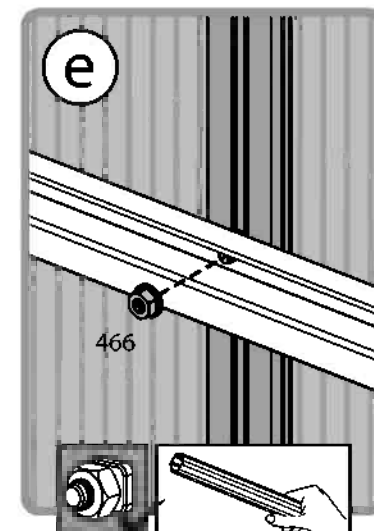
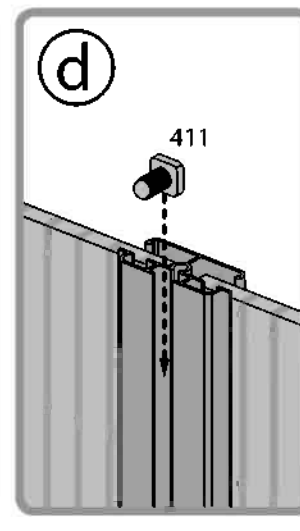
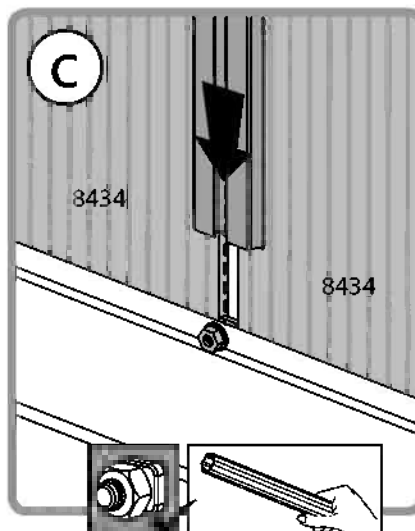
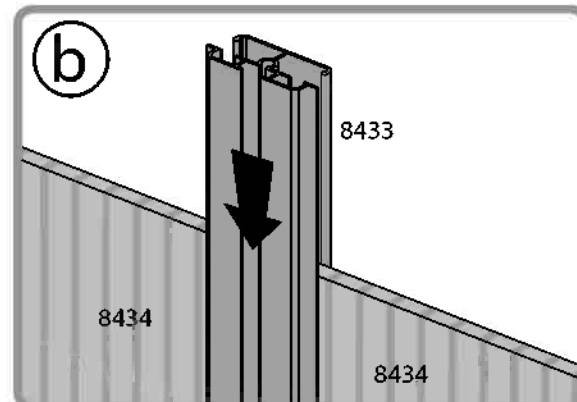
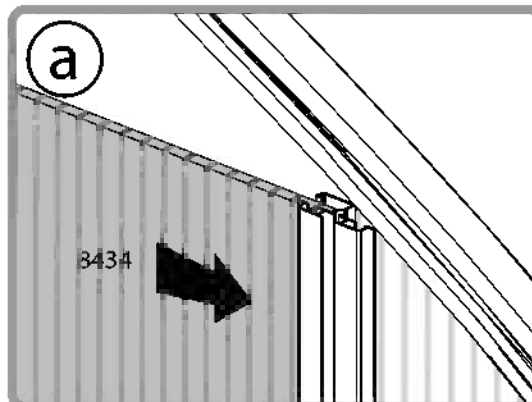
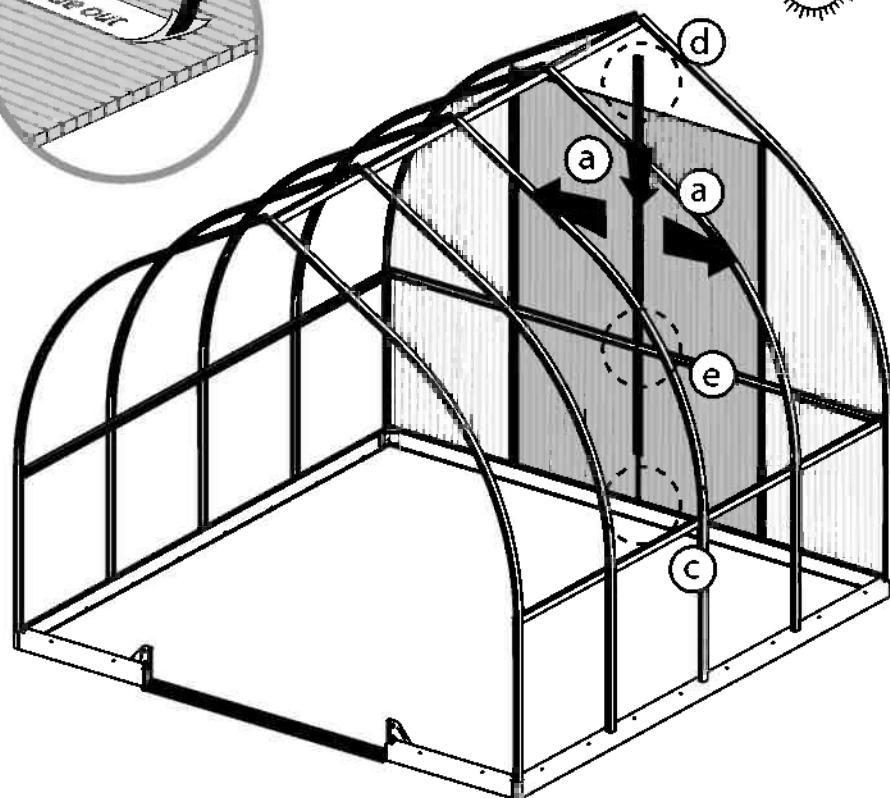

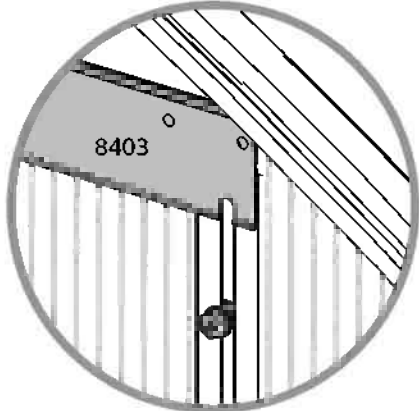
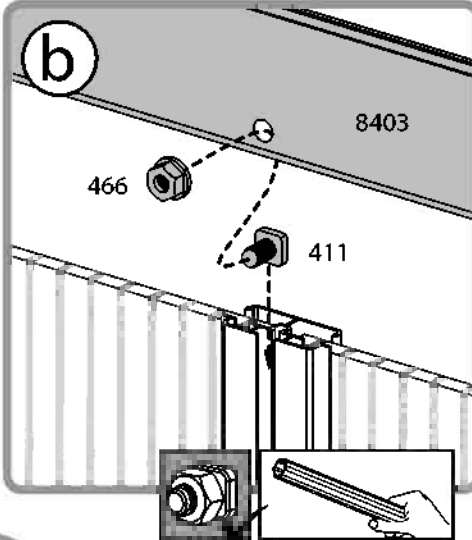
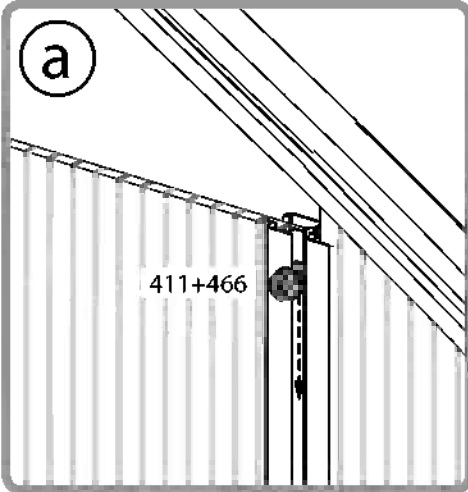
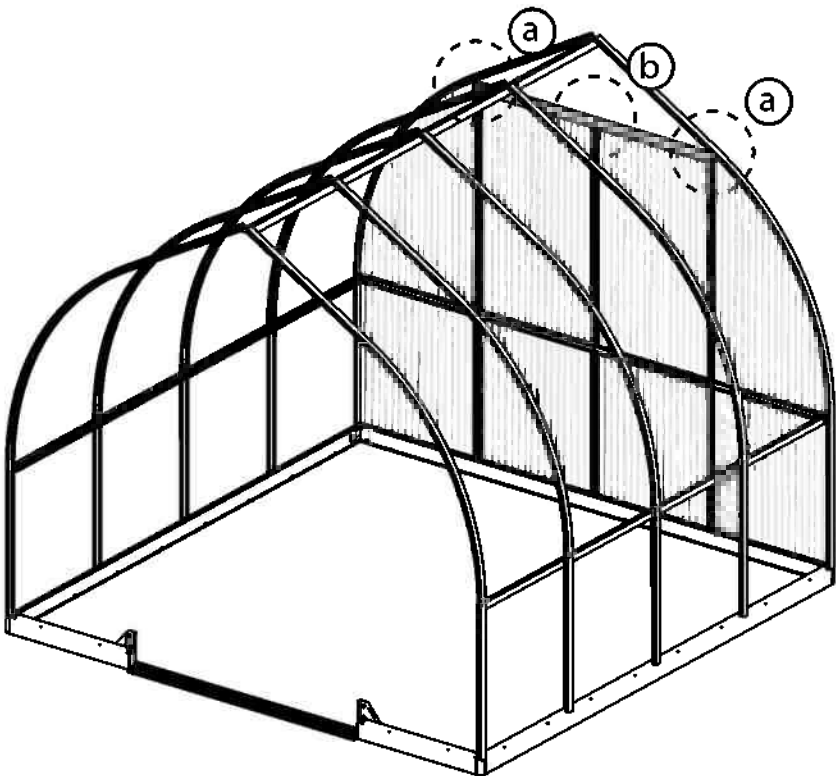
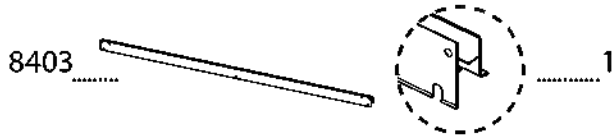

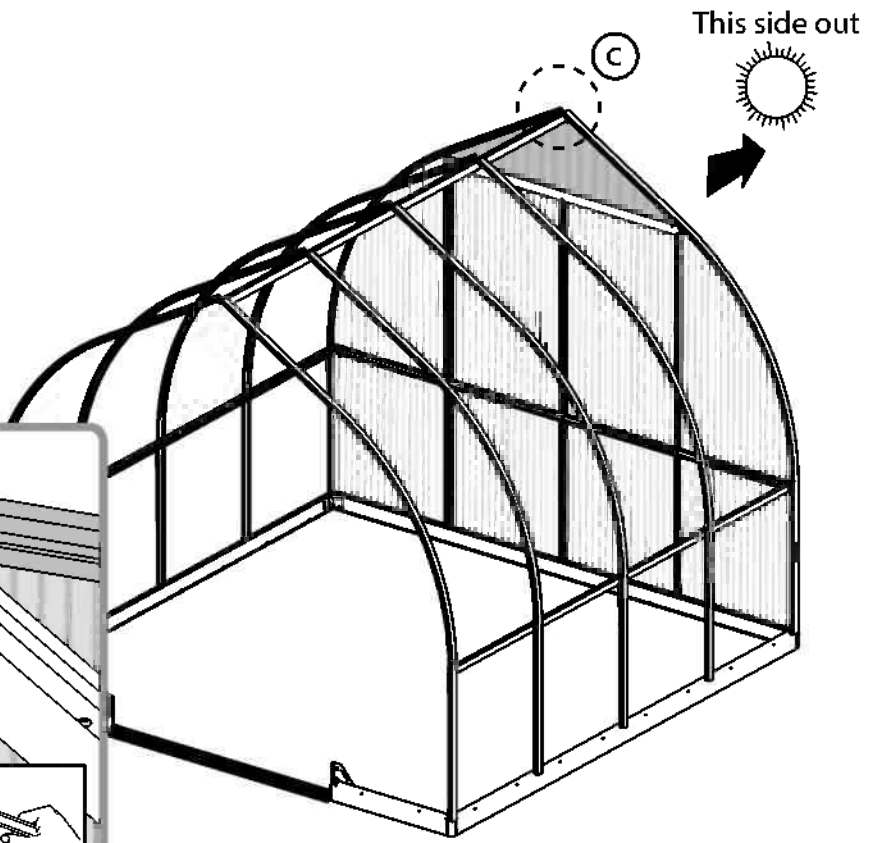
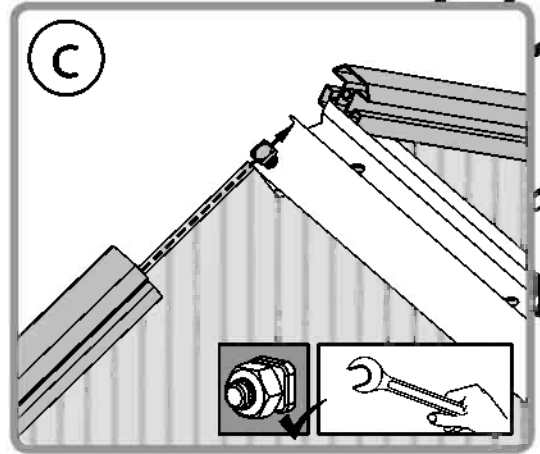
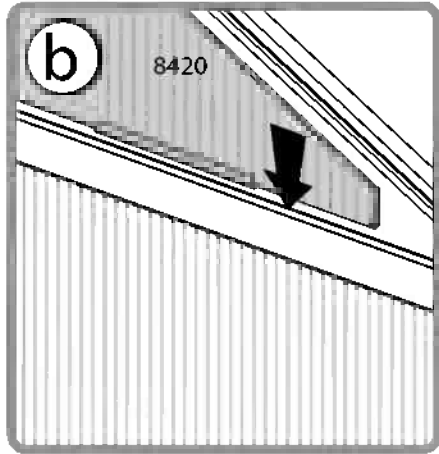
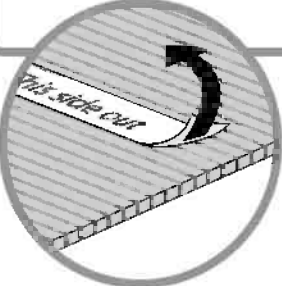
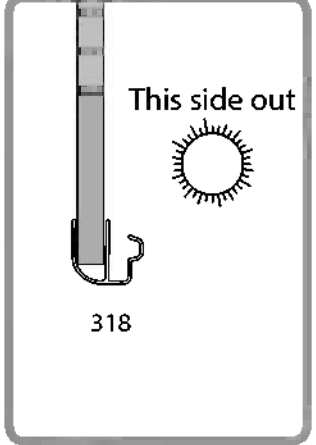
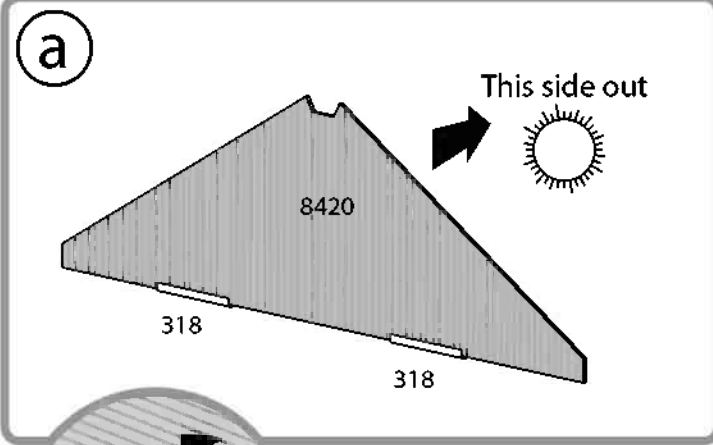
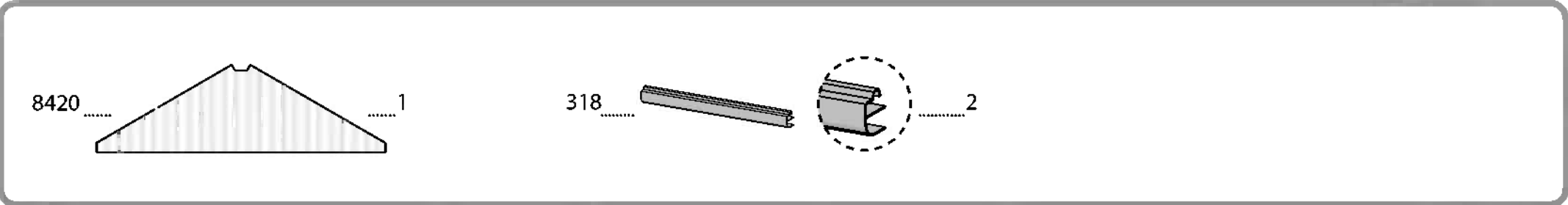
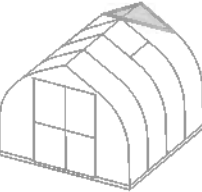

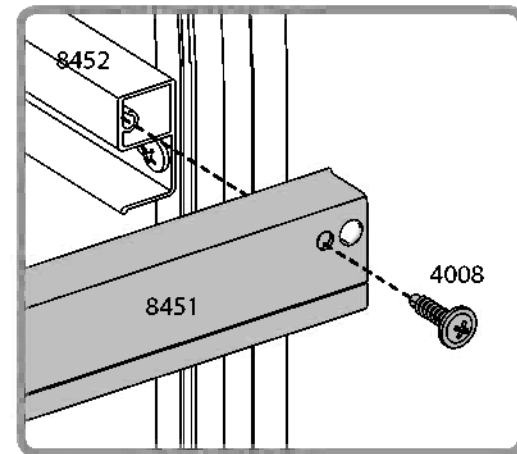
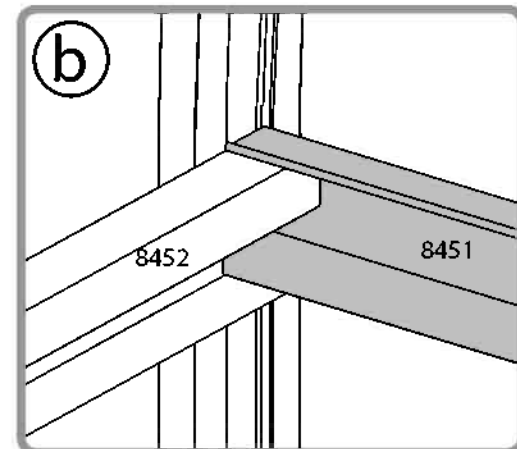
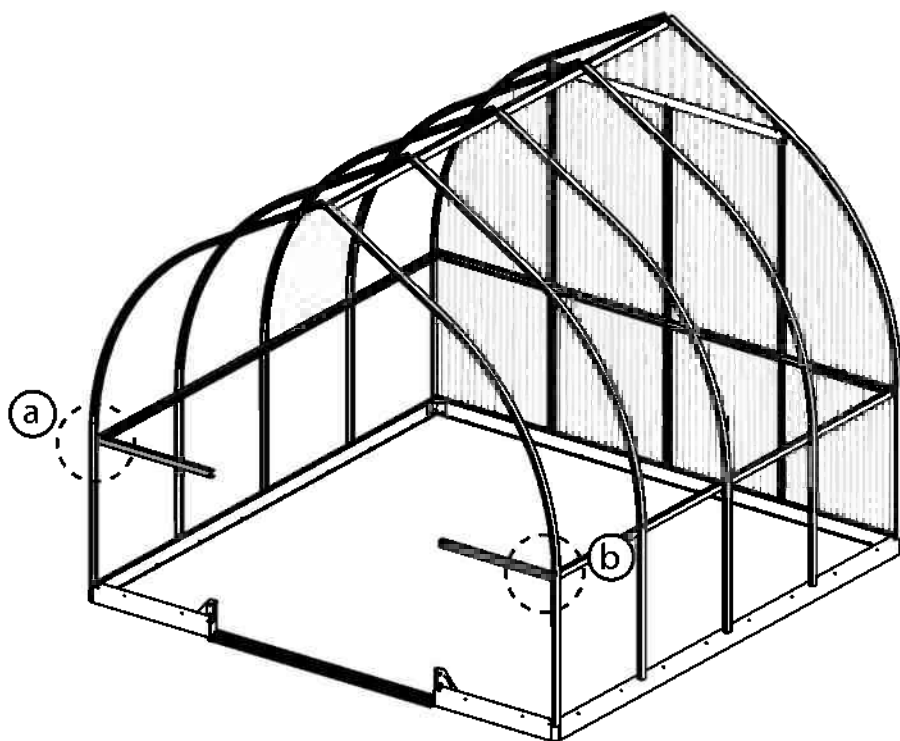
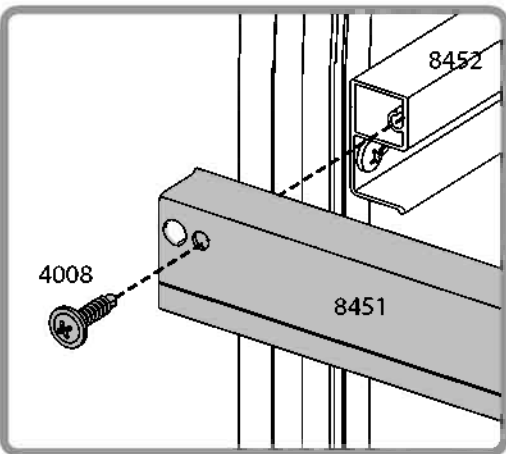
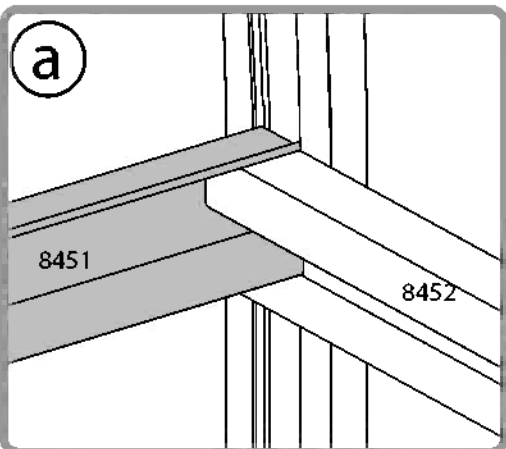
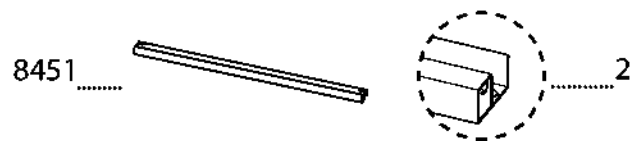
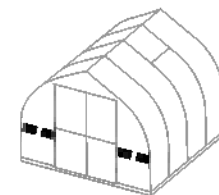

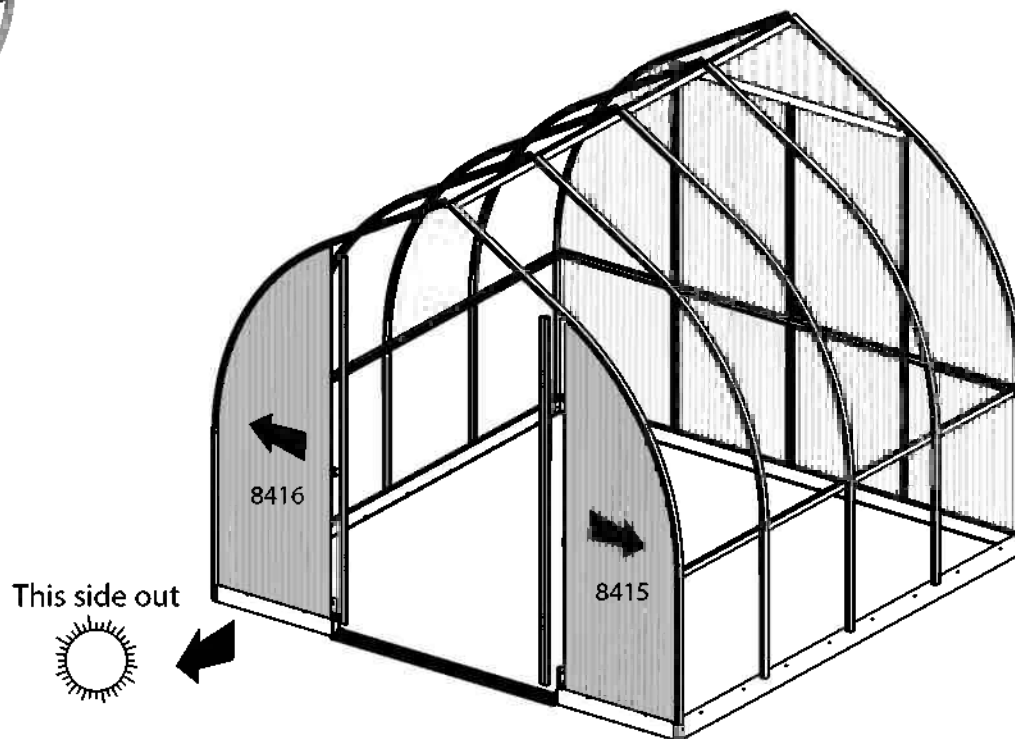
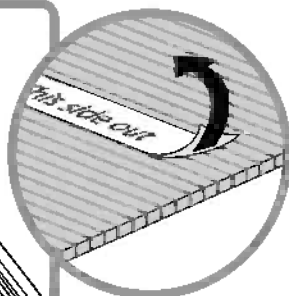
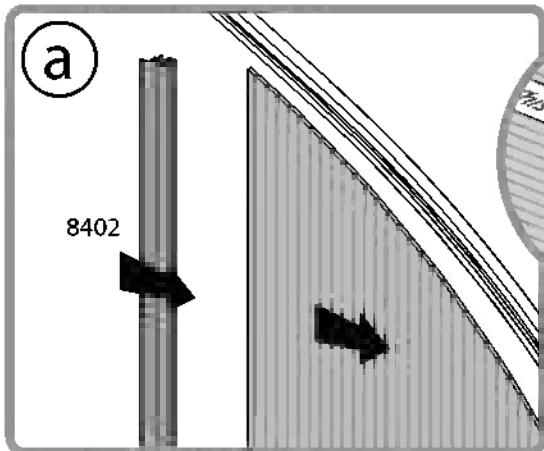
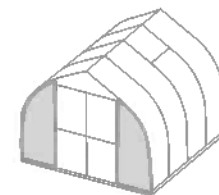

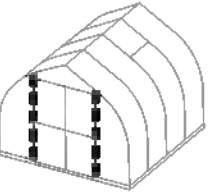

411..... 2

466..... 2

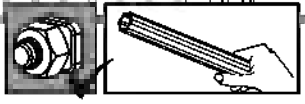
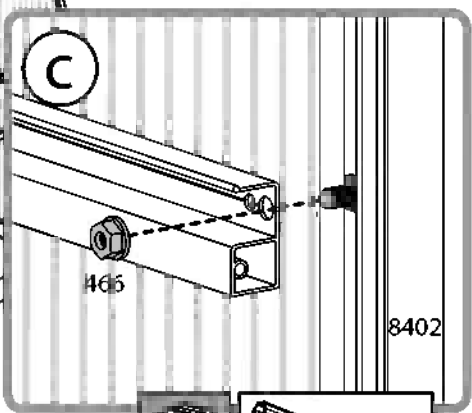
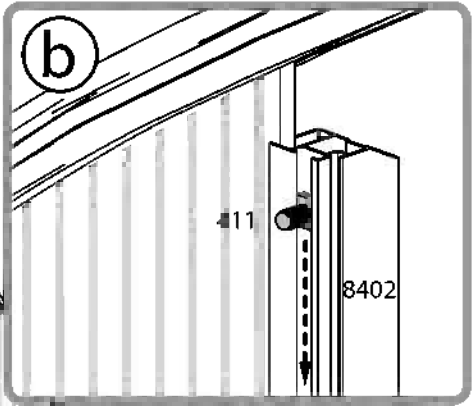
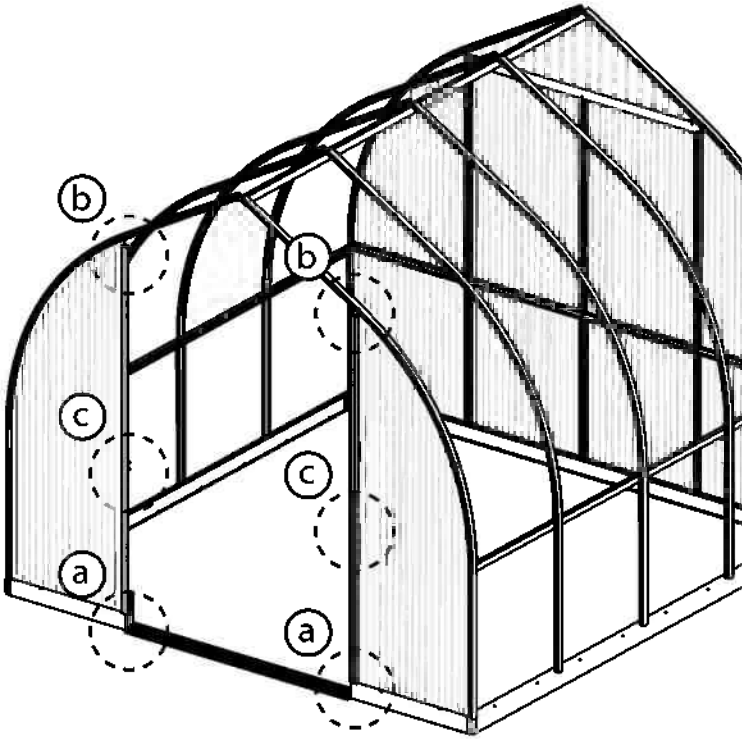
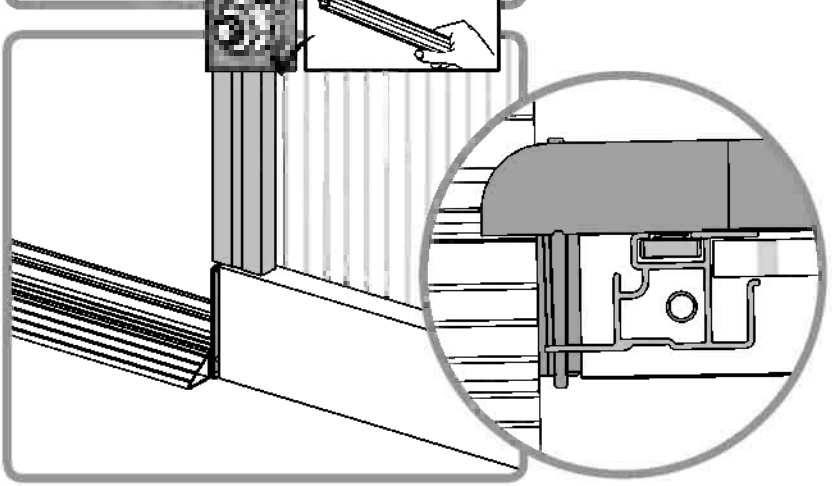
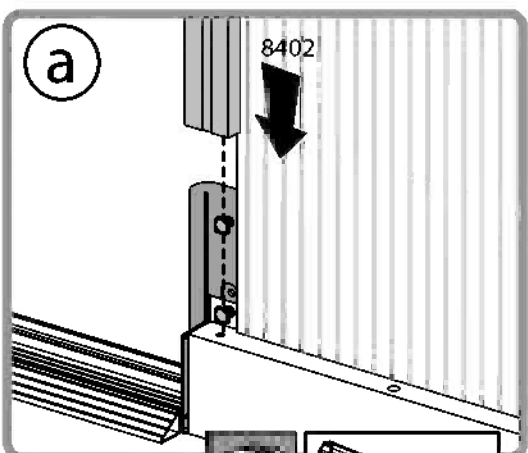

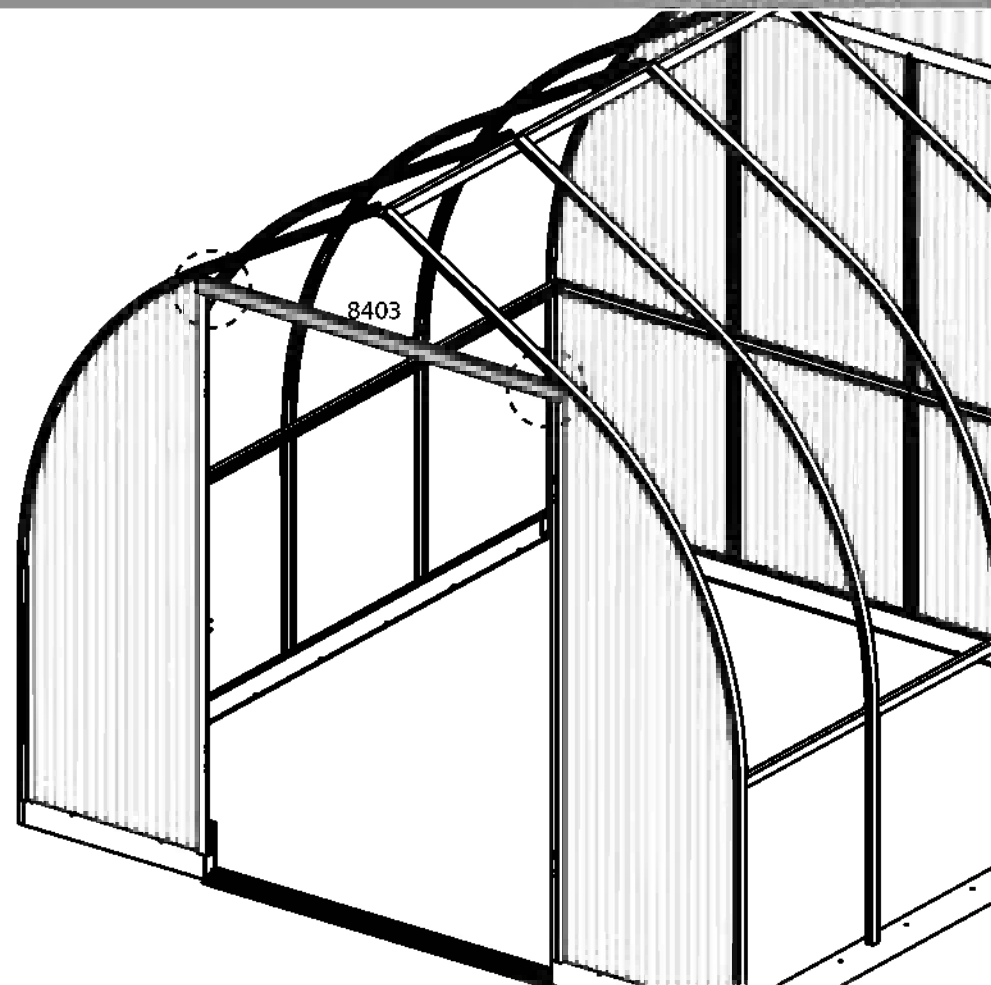
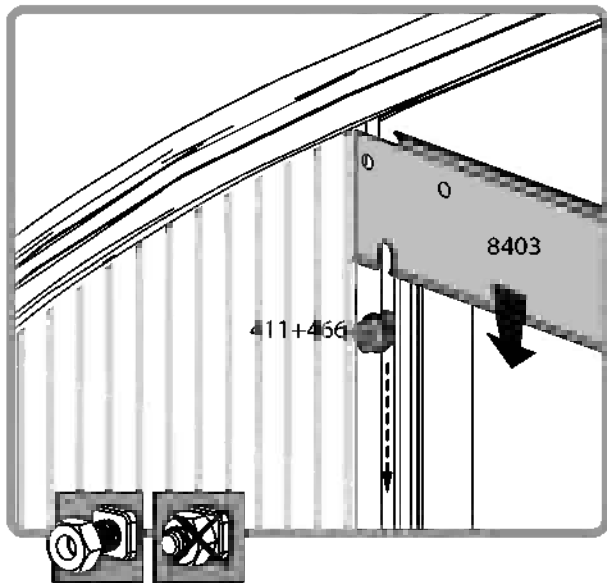
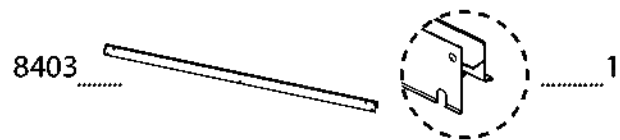

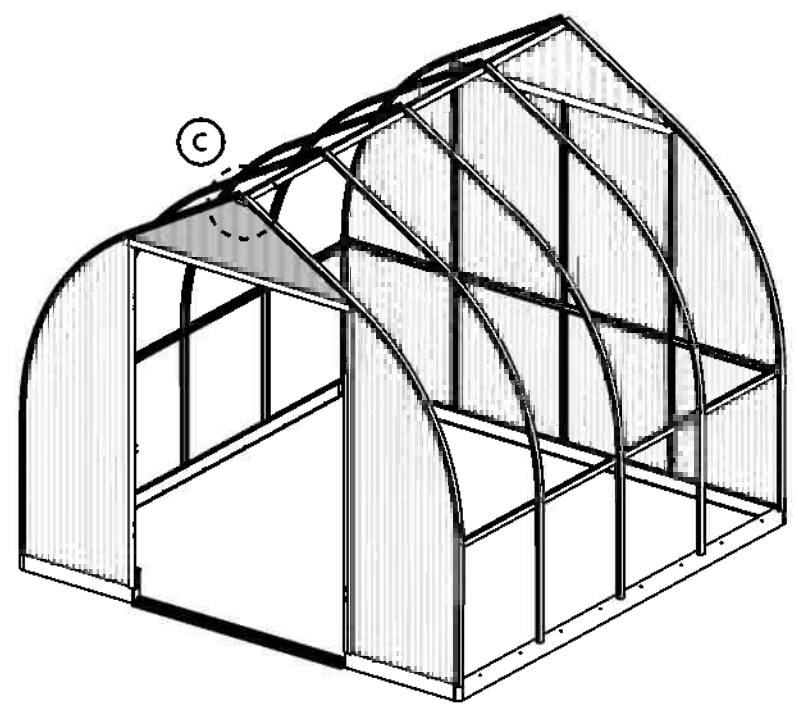
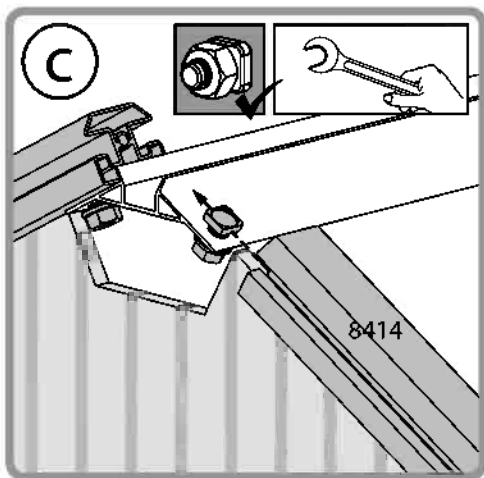
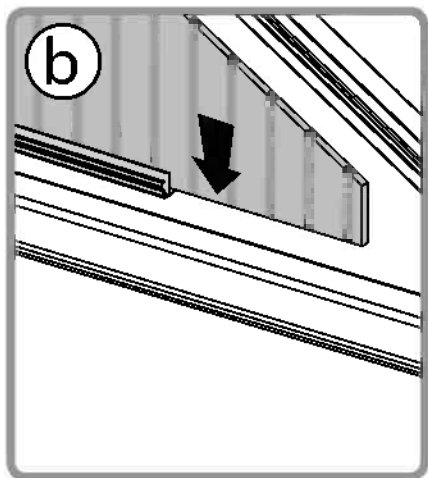
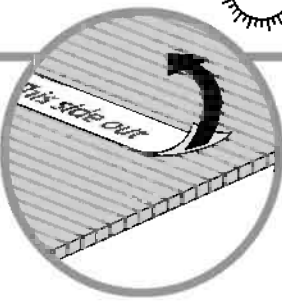
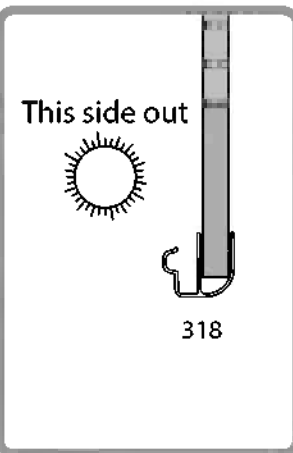
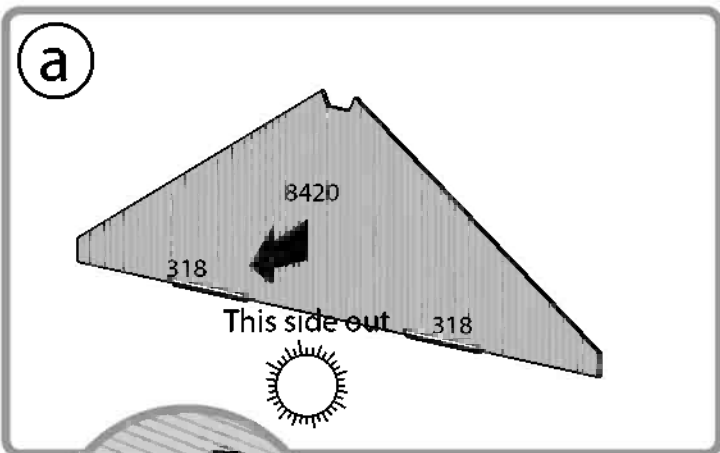
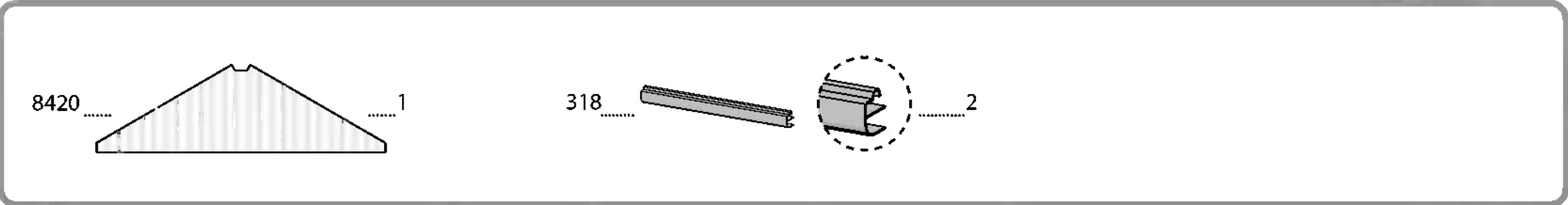
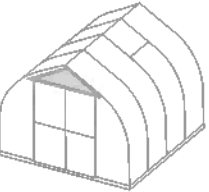

29 For Extension Kit Only

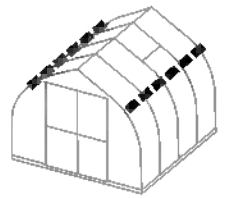

- 8452 2
- 8453 2
- 8455 2
- 4045 8

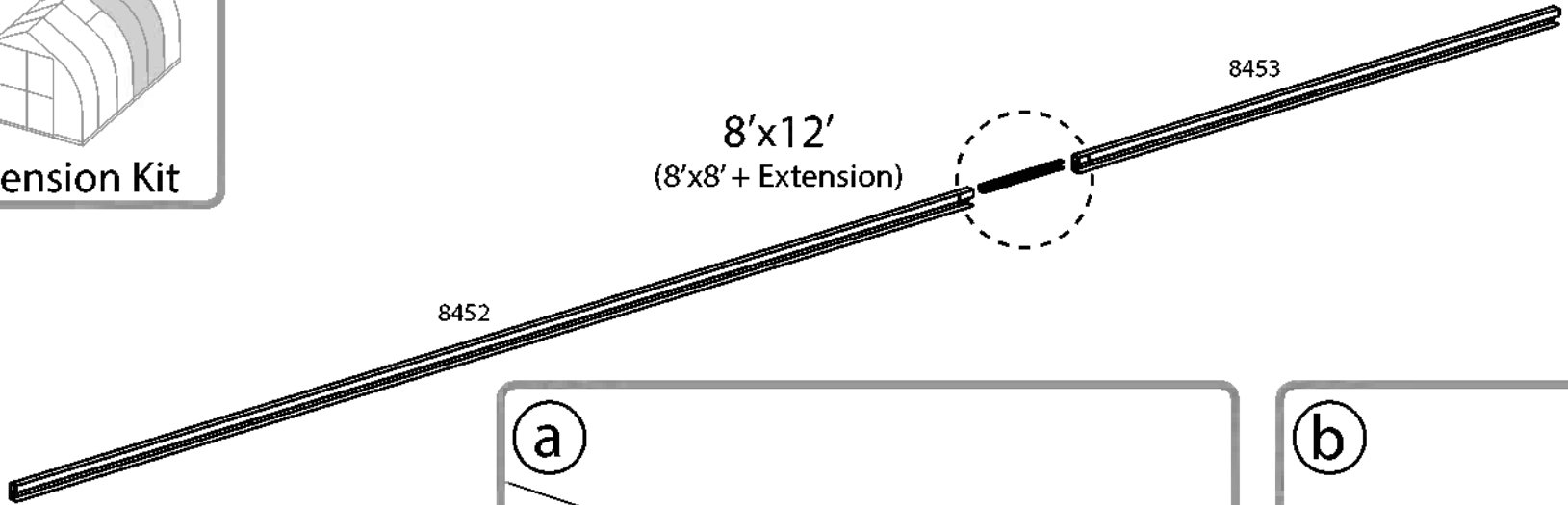

x2

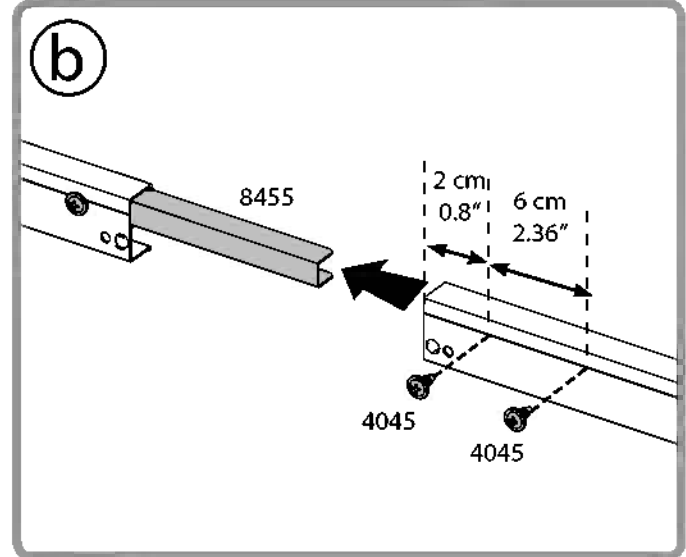
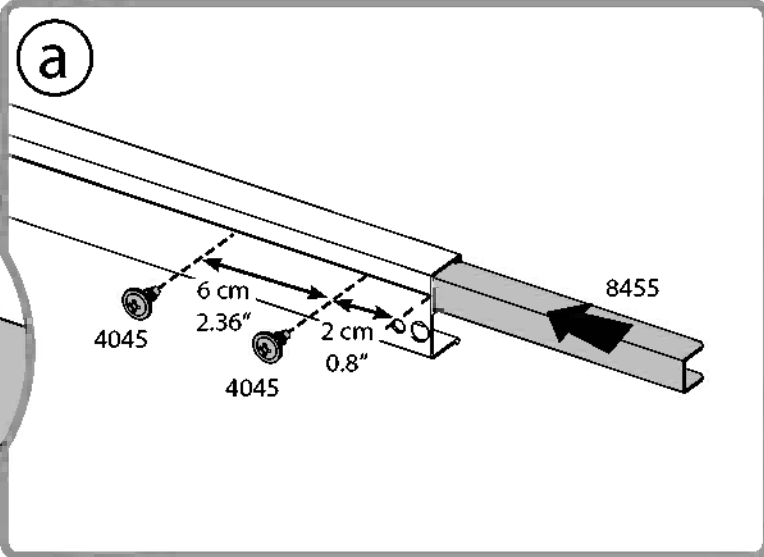
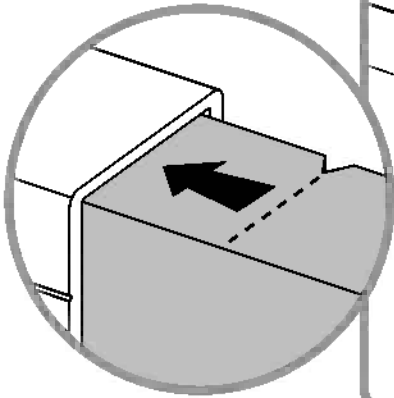

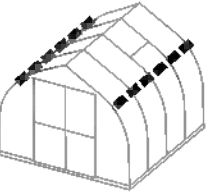

8452.....

8454..... 4

4008..... 4

8452+8453..... 2

Extension Kit

8452

8452

8452+8453

8452+8453

Extension Kit

a

b

a

b

a

b

8452

8454

4008

8452

8454

4008

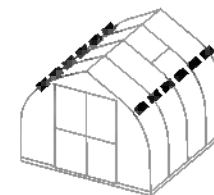

7335  12

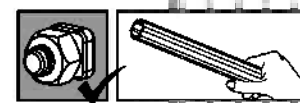
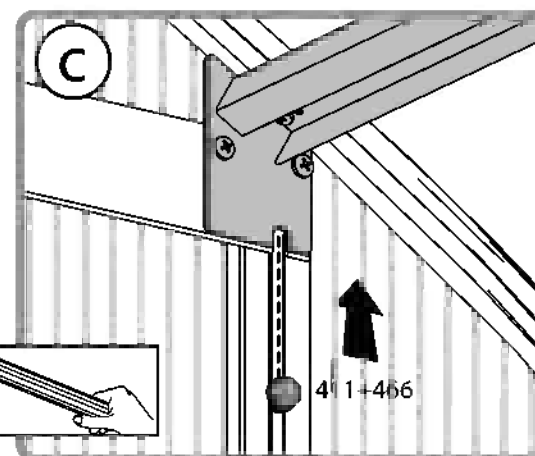
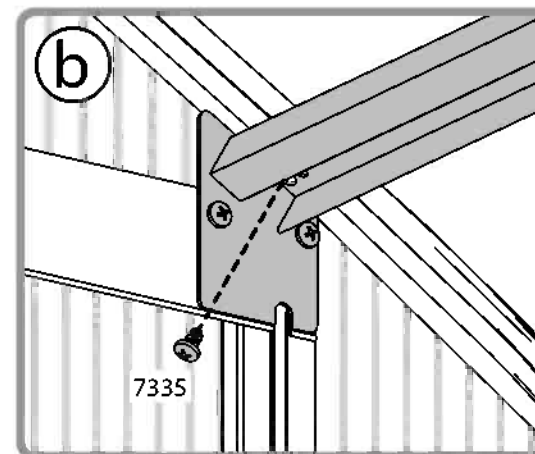
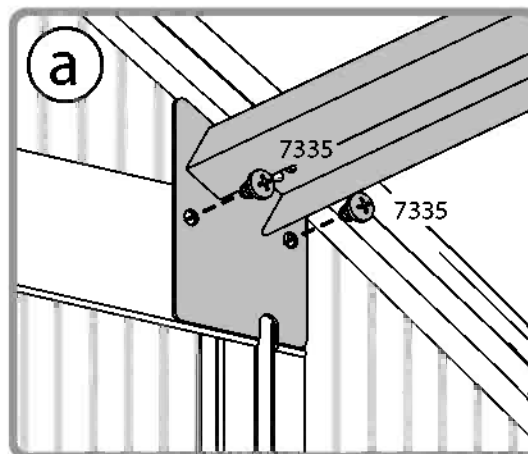
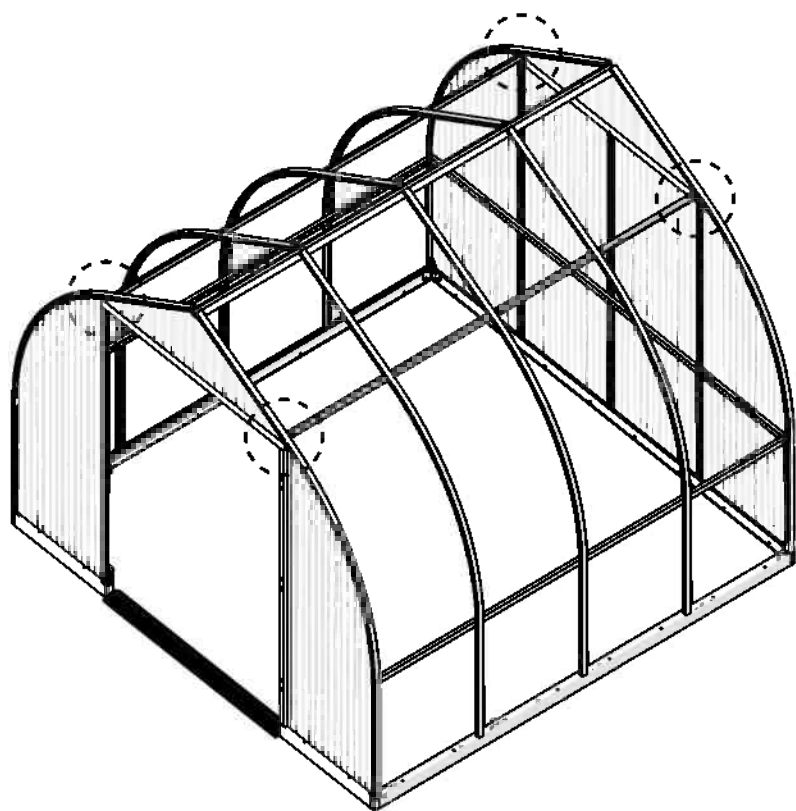

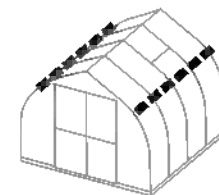

466  6

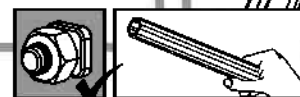
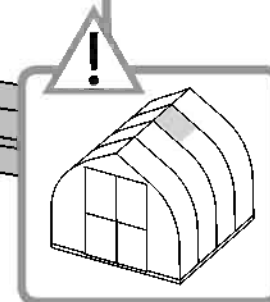
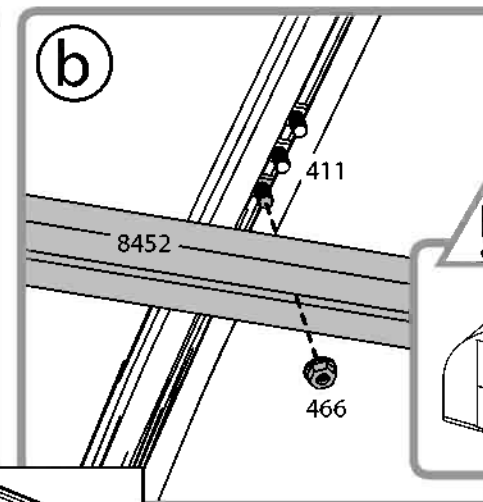
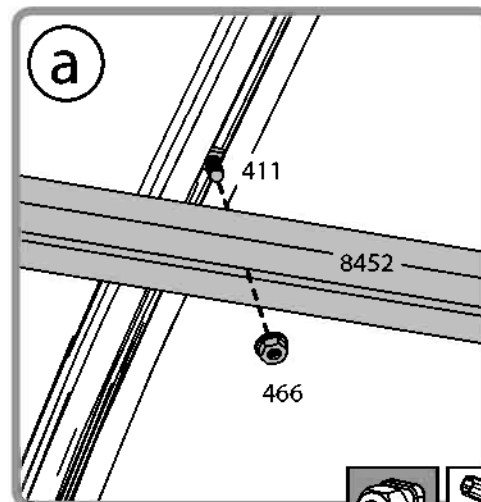
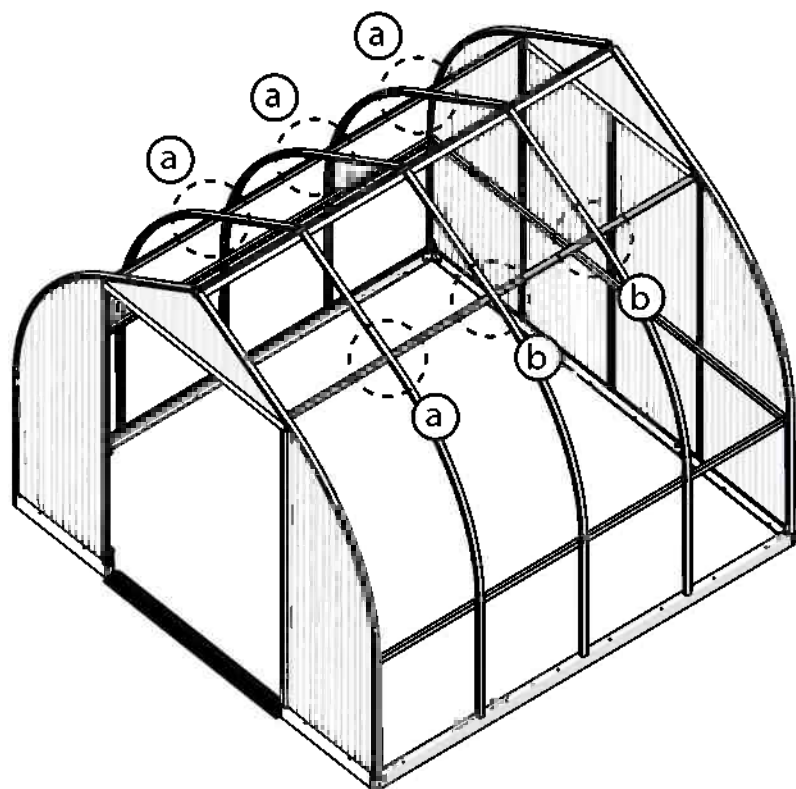

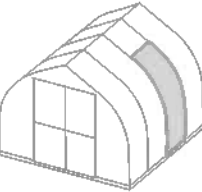

8419.....

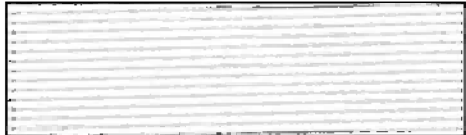

.....1



Extension Kit

8419.....+1

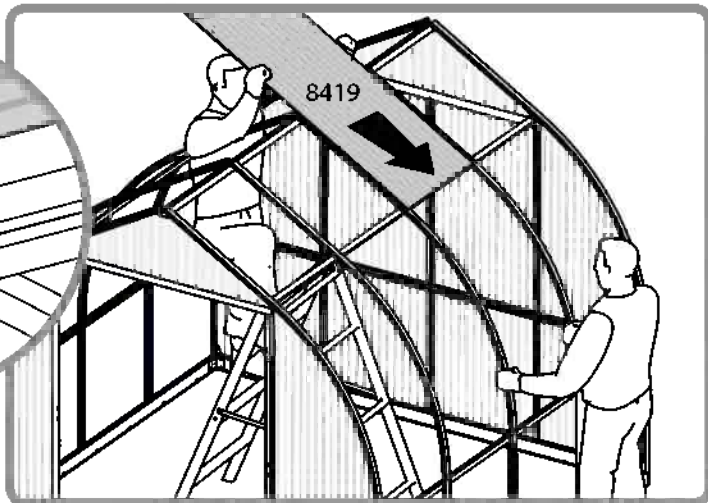
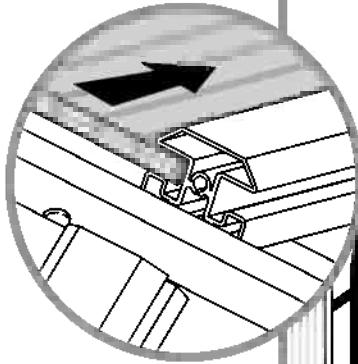
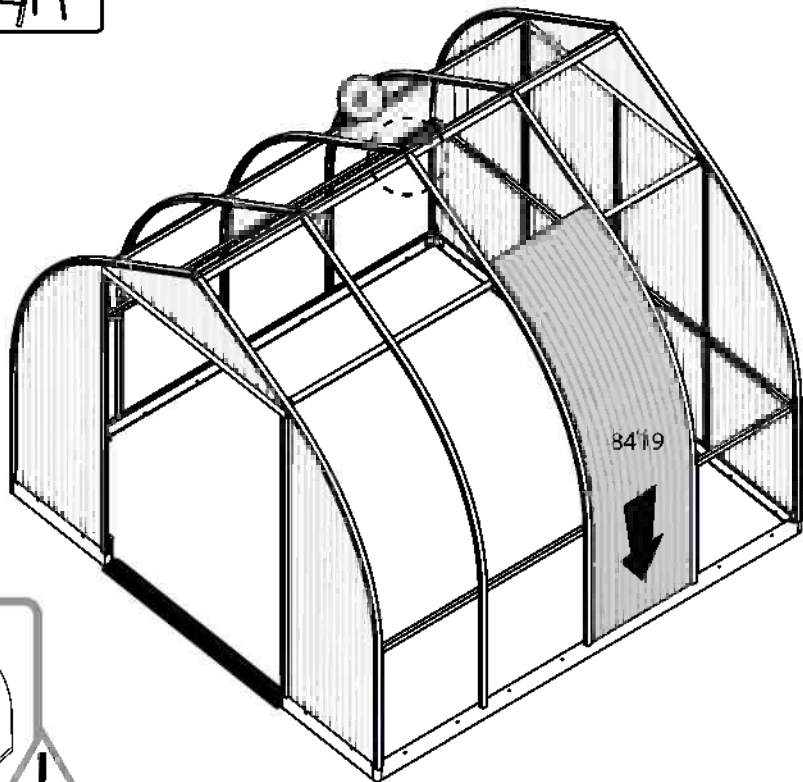

Extension Kit

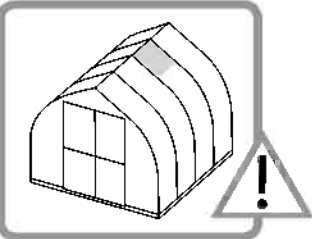
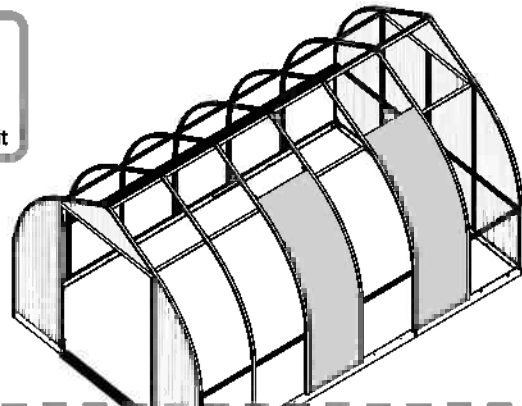

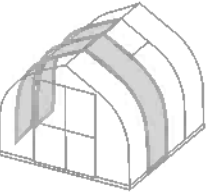

8418.....

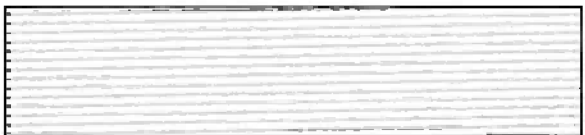

.....3



Extension Kit

8418.....+3

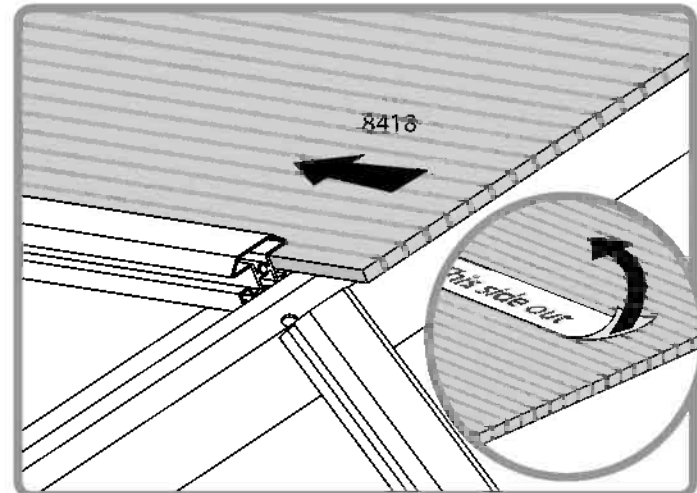
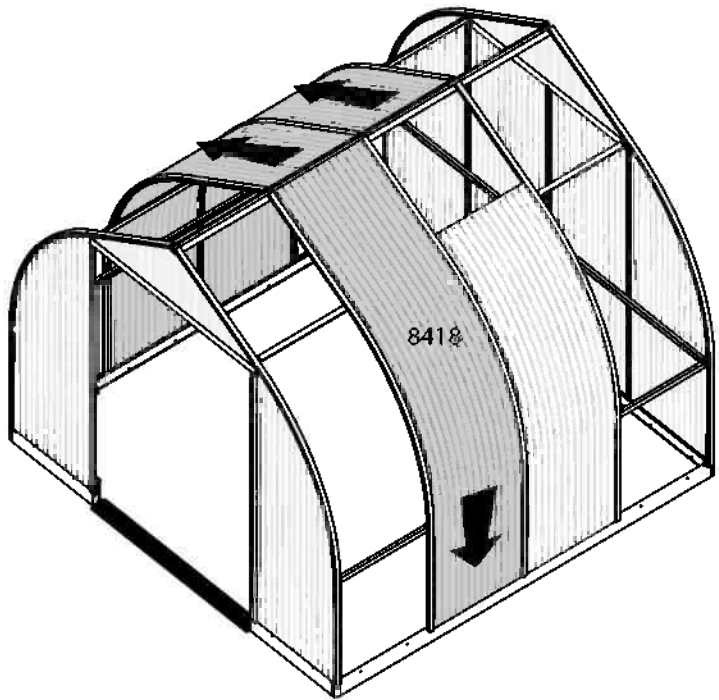
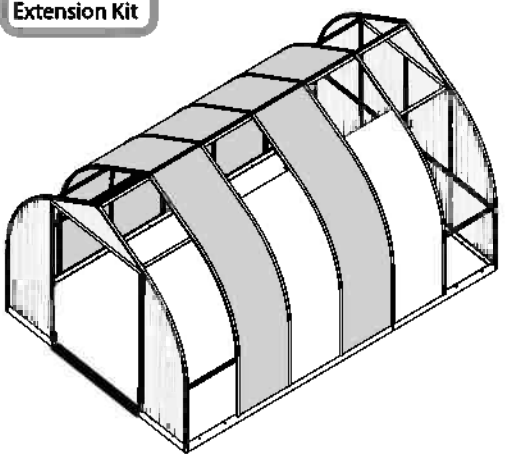

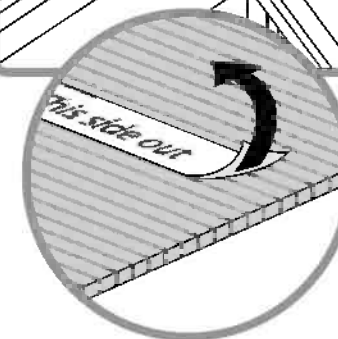
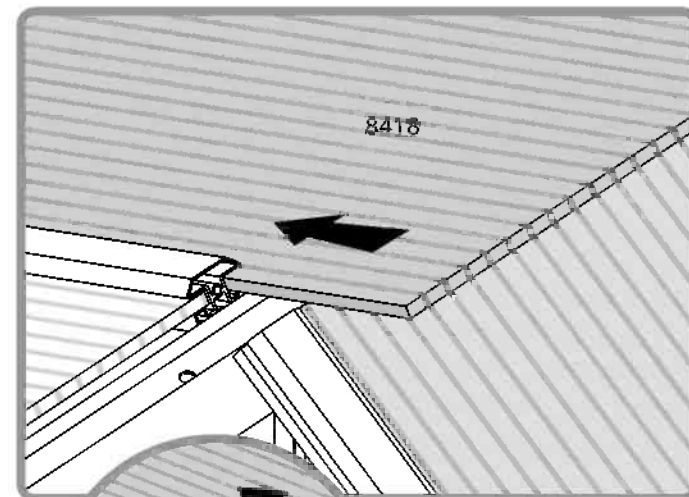
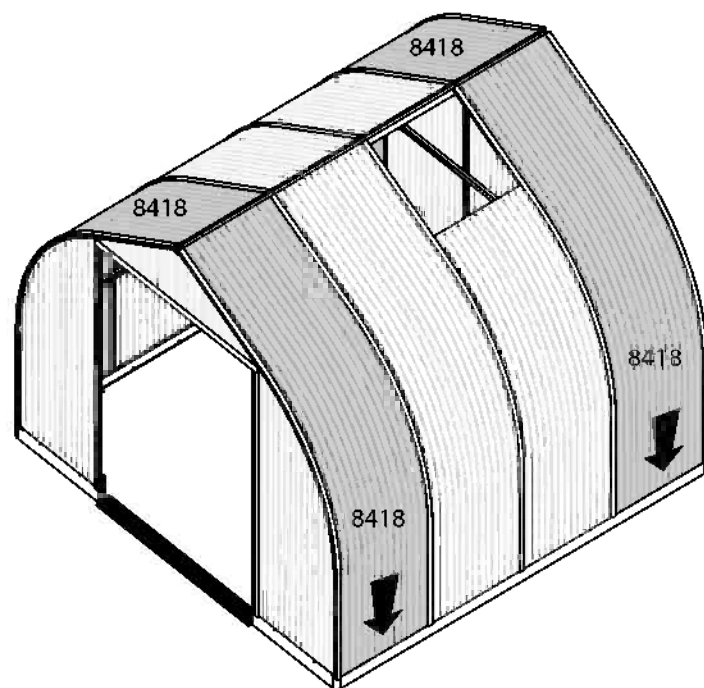
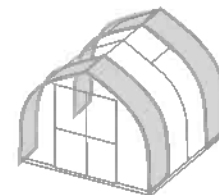

36 For Extension Kit Only

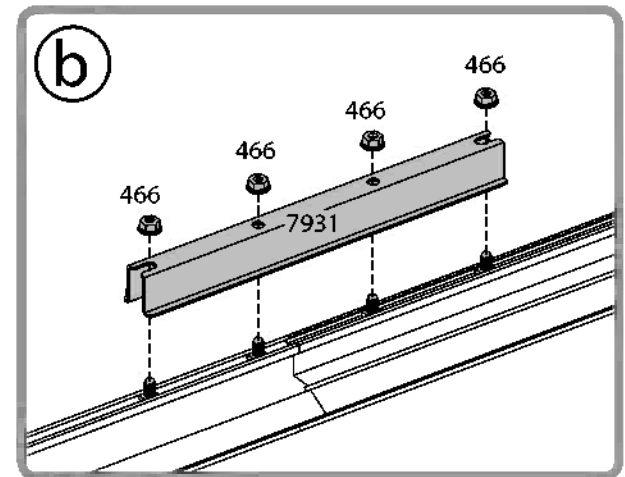
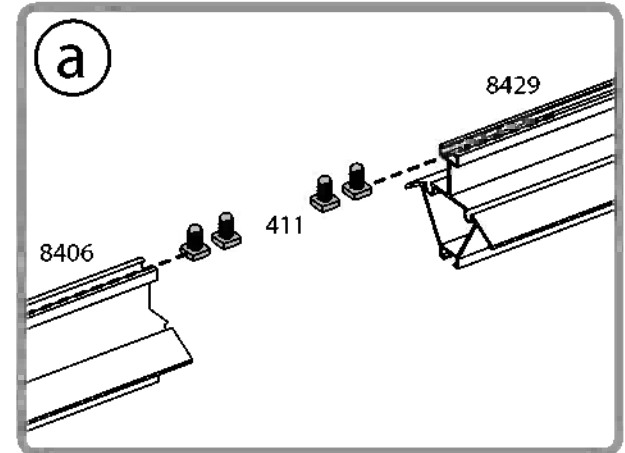
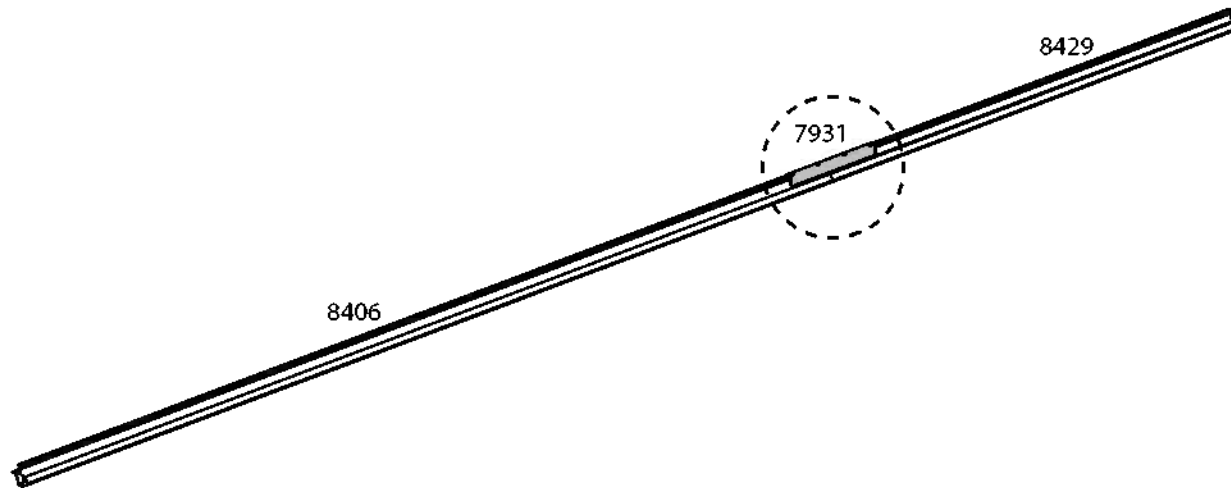
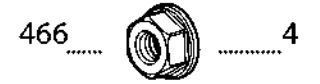
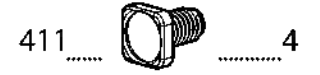
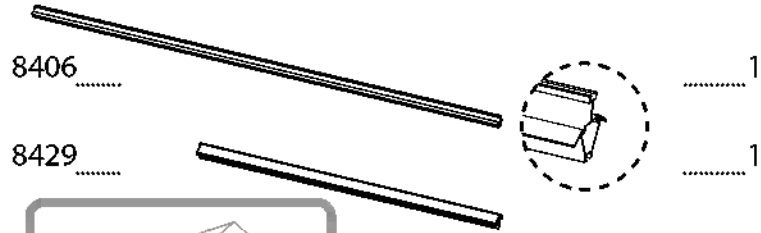
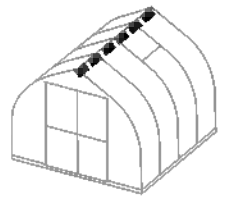

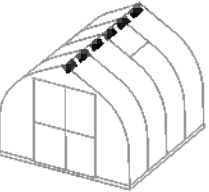

411 +1
466 +1

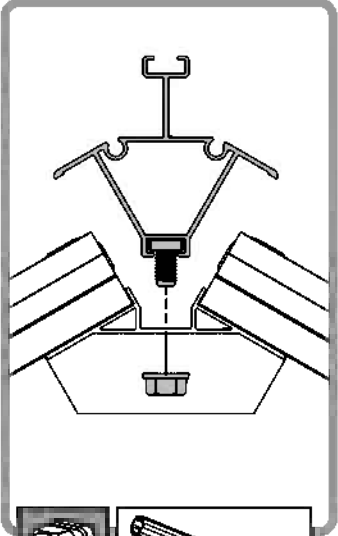
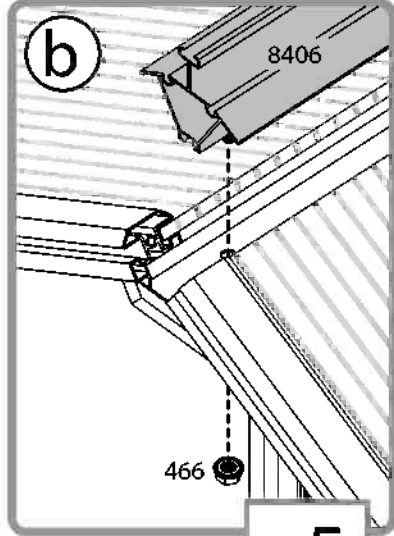
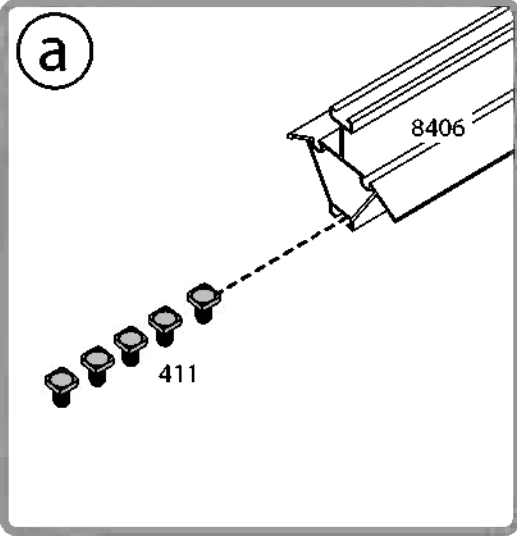
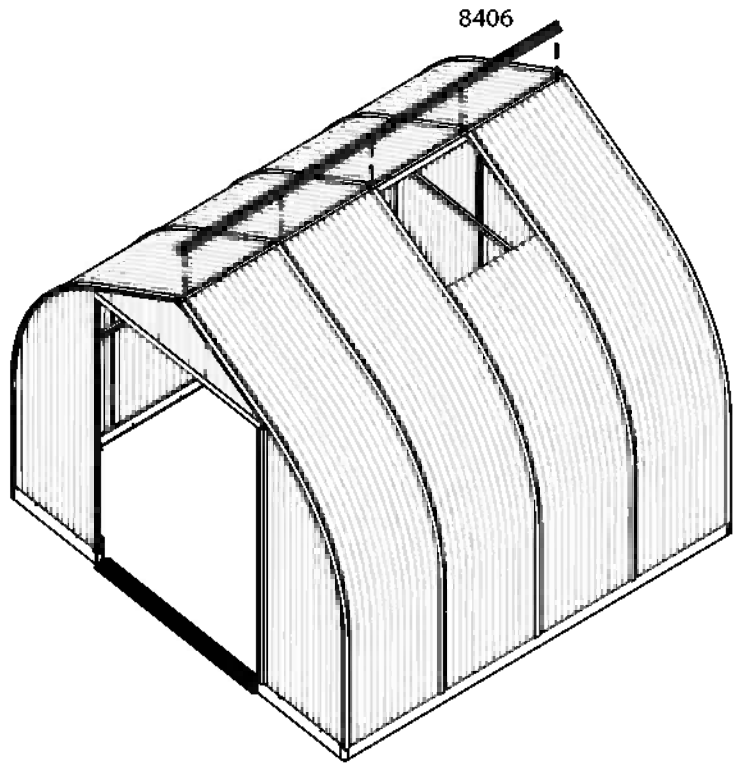

x5

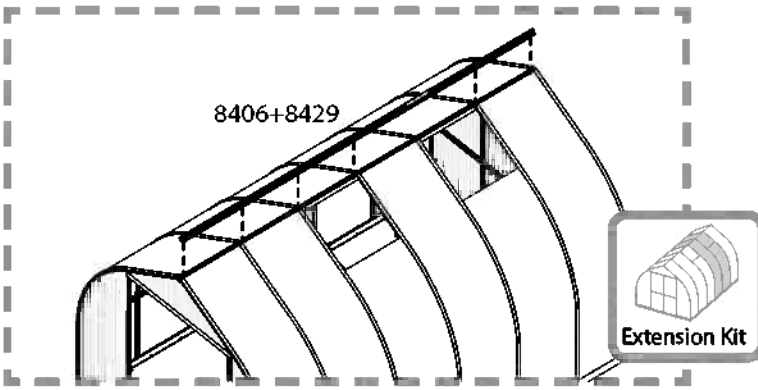
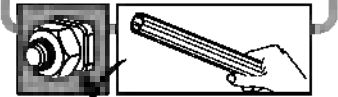

Extension Kit

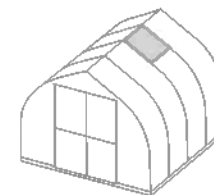

<p>8421 1</p>	<p>8710 2</p>	<p>411 2</p> <p>466 6</p>	<div style="border: 1px dashed gray; padding: 5px;"> <p>Extension Kit</p> <table border="0"> <tr> <td>8421</td> <td>.....</td> <td>+1</td> </tr> <tr> <td>8710</td> <td>.....</td> <td>+2</td> </tr> <tr> <td>411</td> <td>.....</td> <td>+2</td> </tr> <tr> <td>466</td> <td>.....</td> <td>+6</td> </tr> </table> </div>	8421	+1	8710	+2	411	+2	466	+6
8421	+1													
8710	+2													
411	+2													
466	+6													

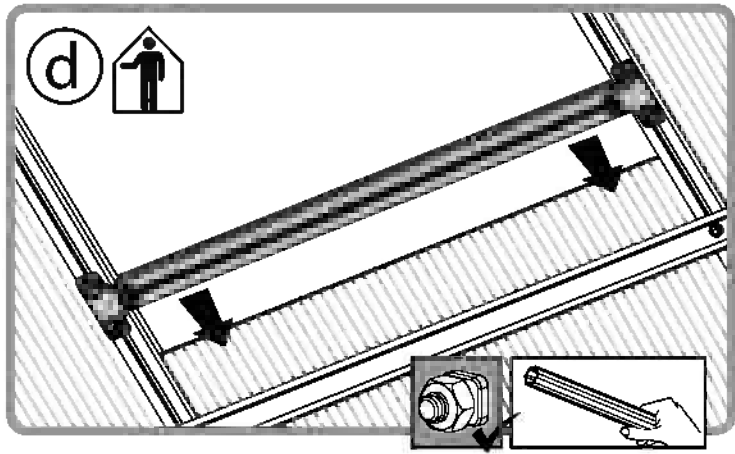
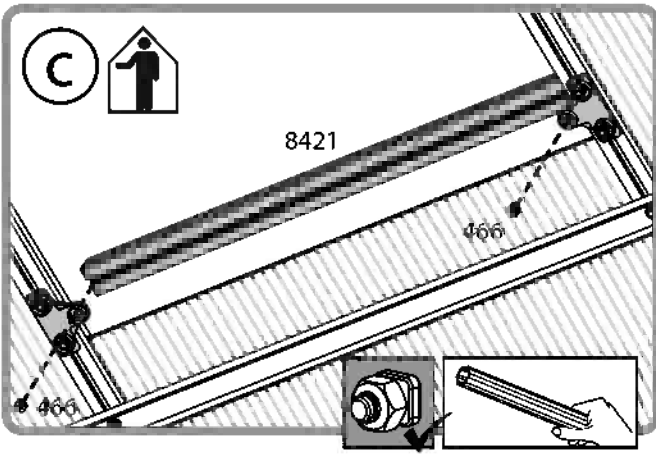
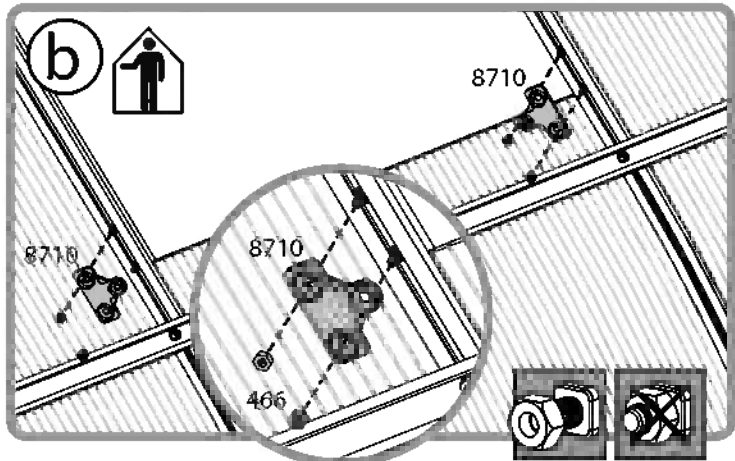
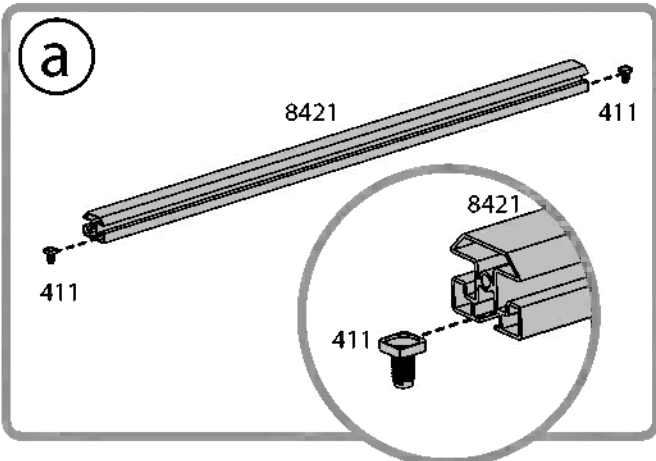
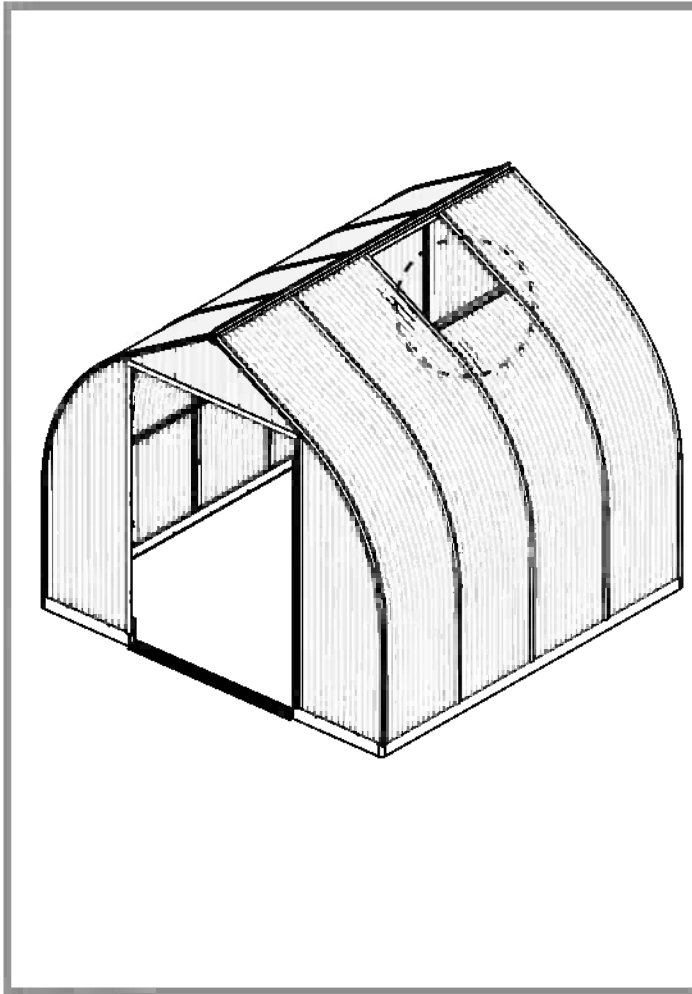

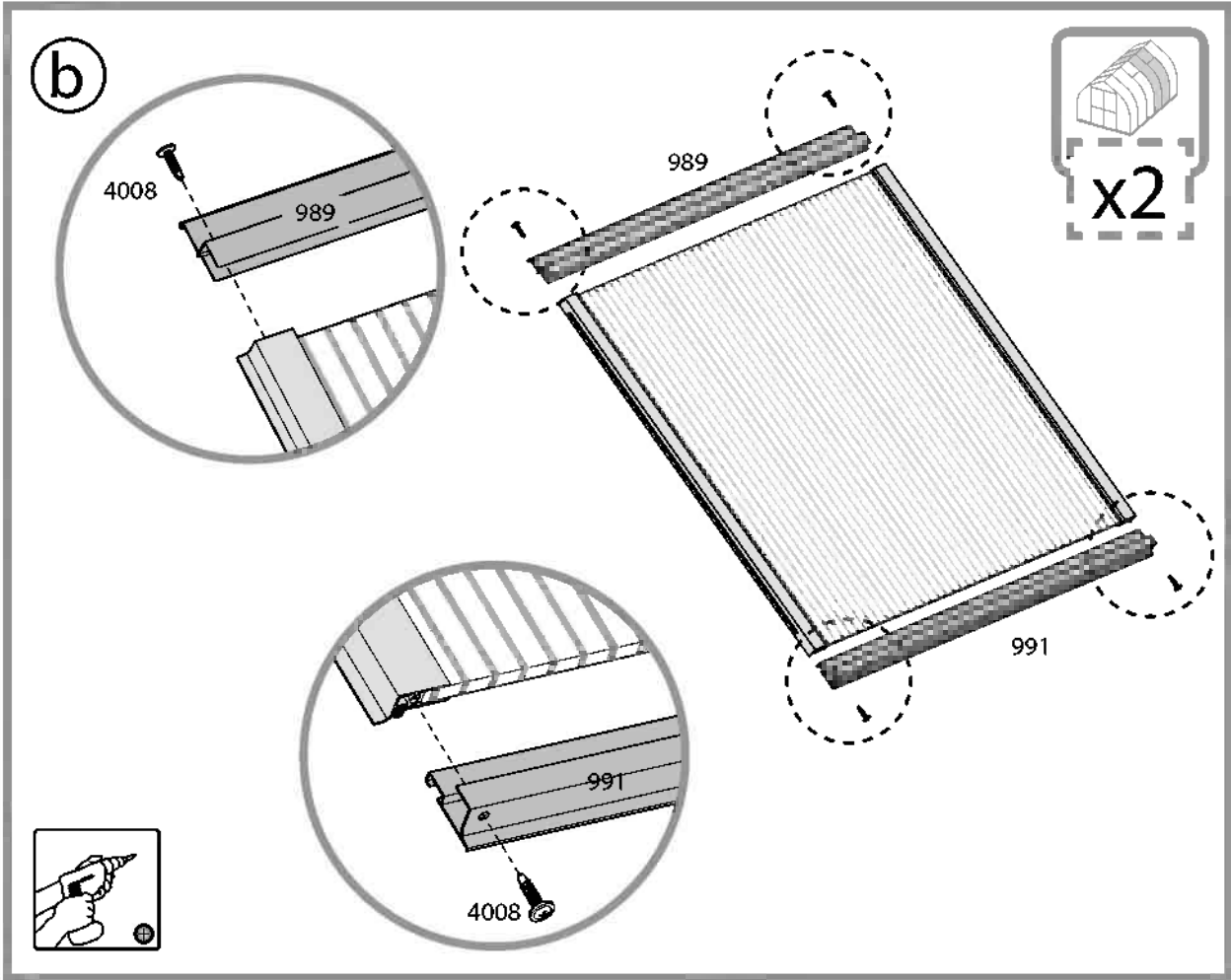
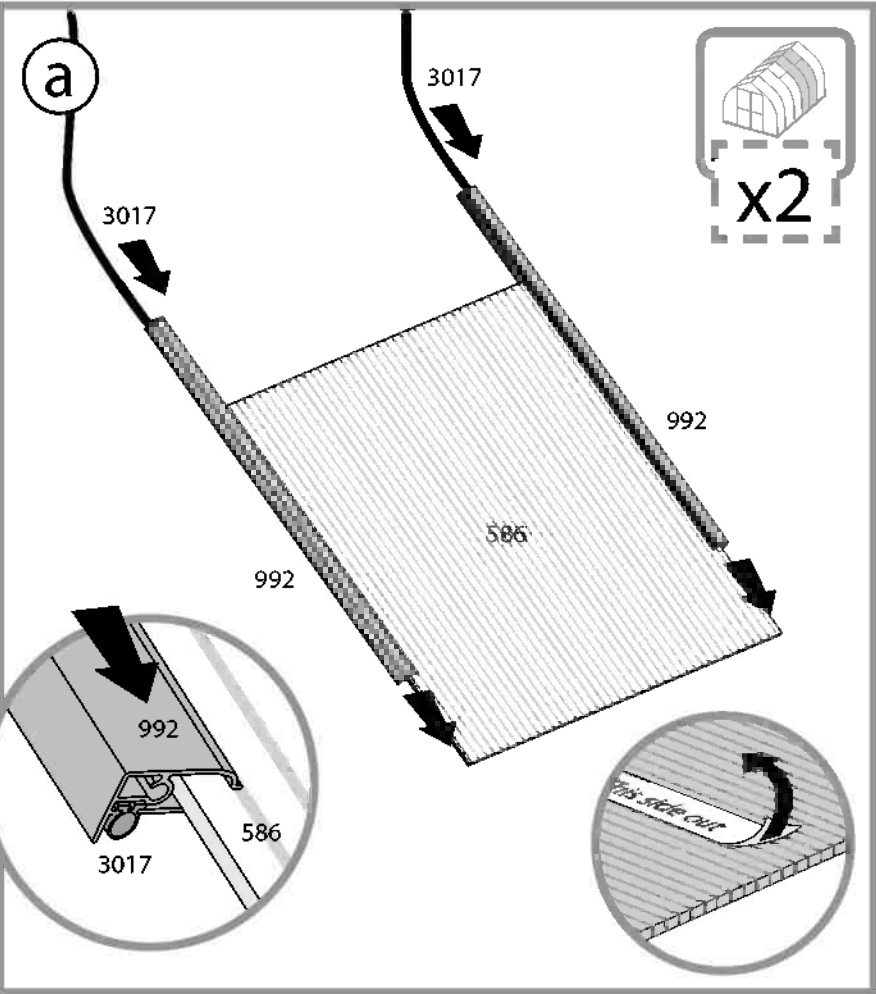
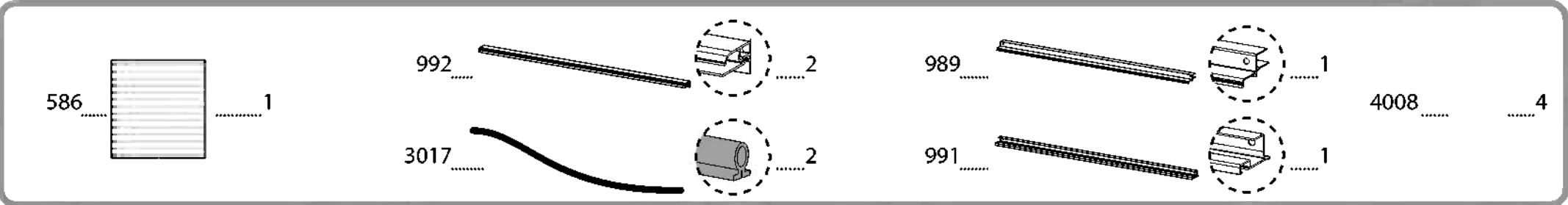
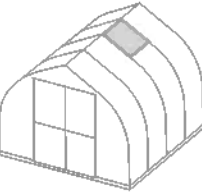

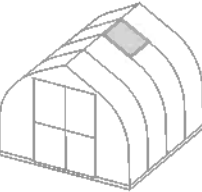

7009 2



7009 +2

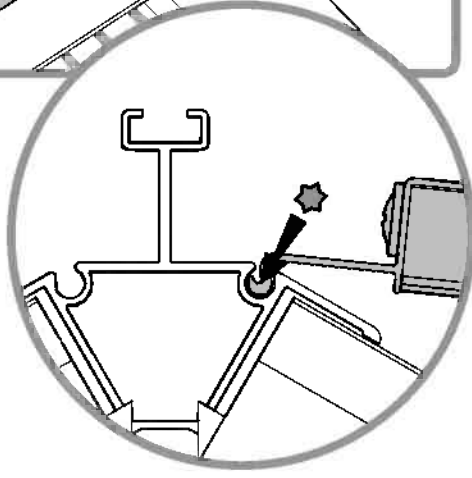
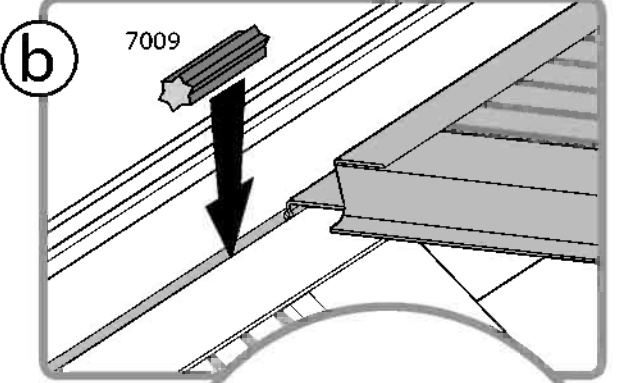
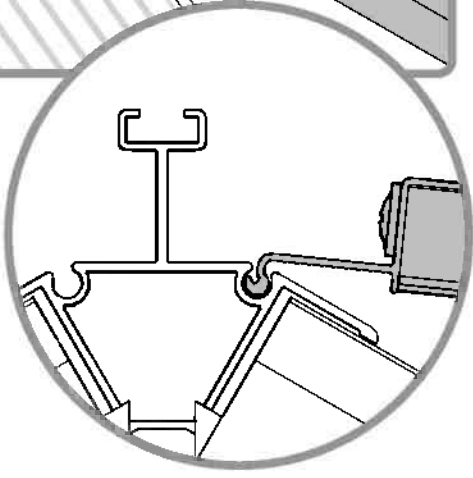
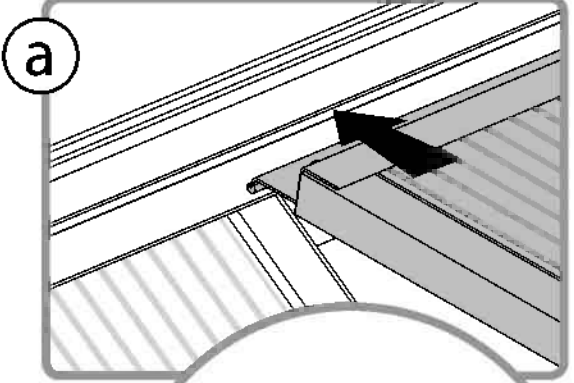
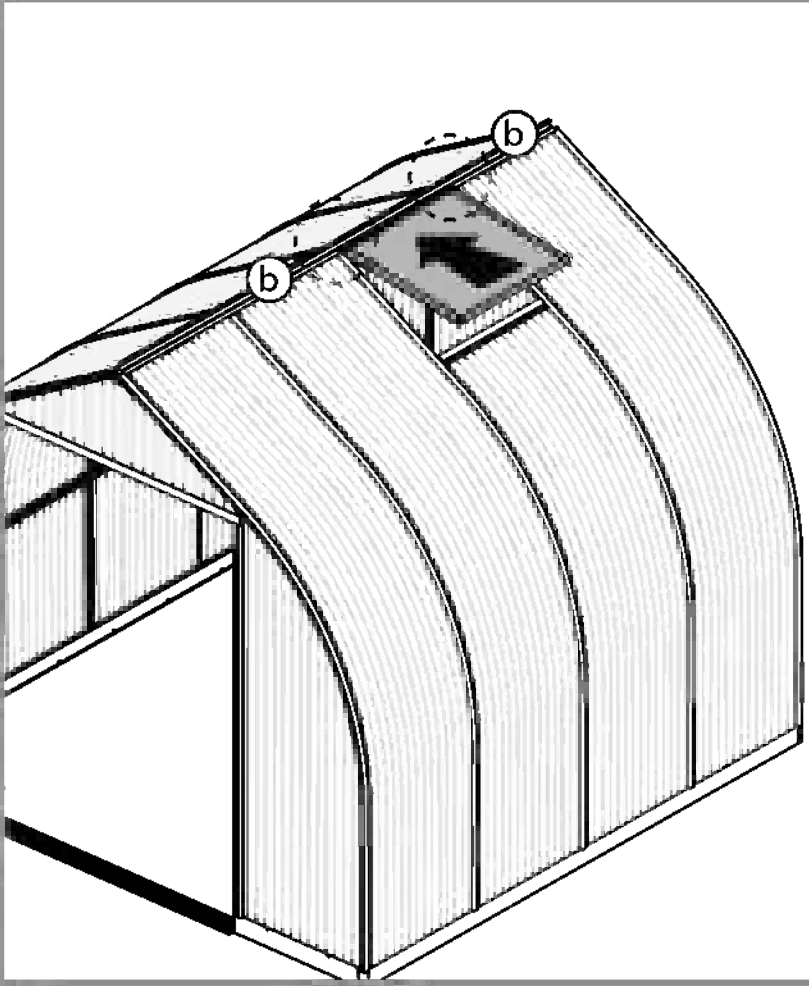

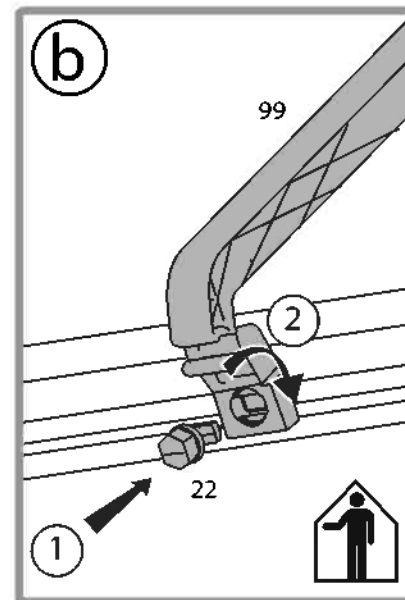
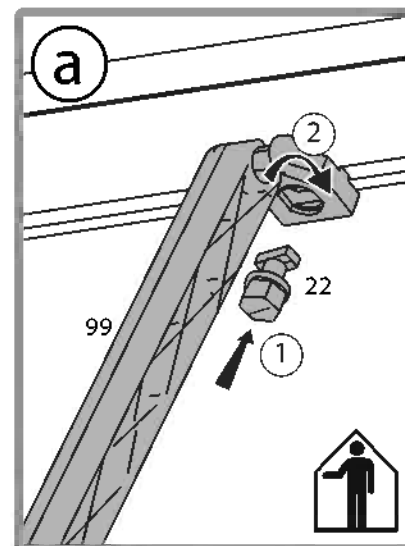
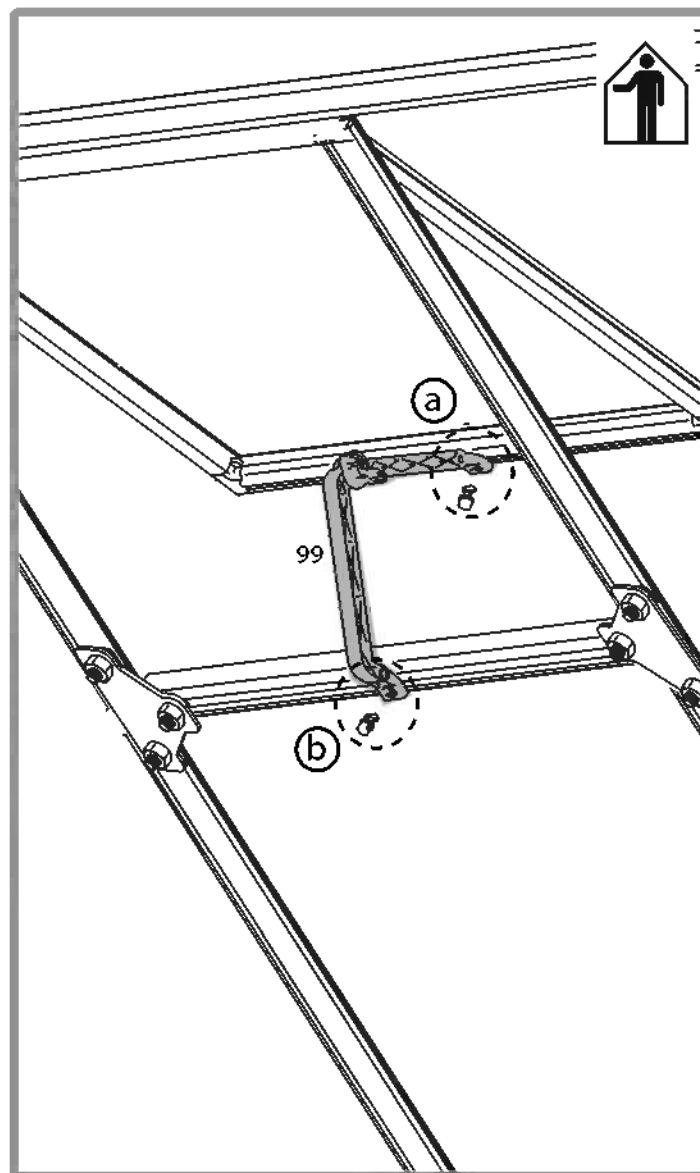
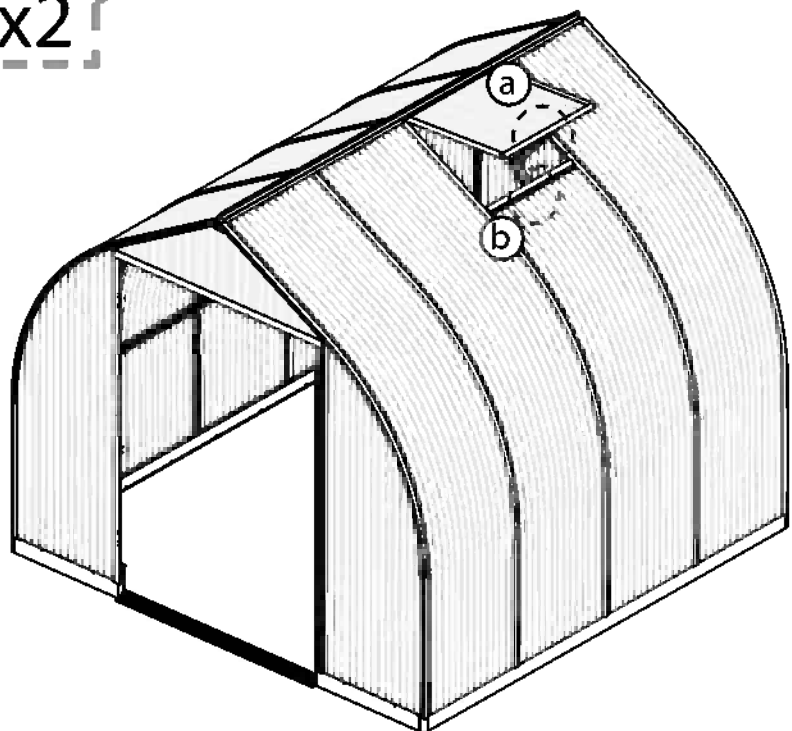
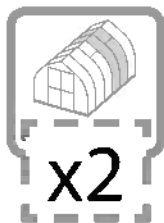
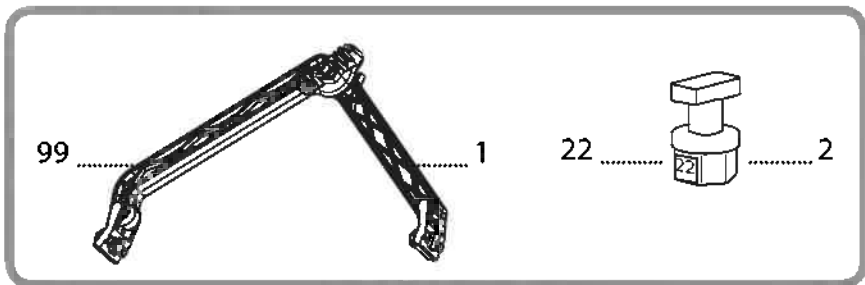
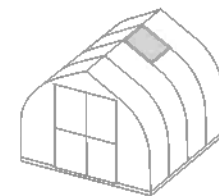

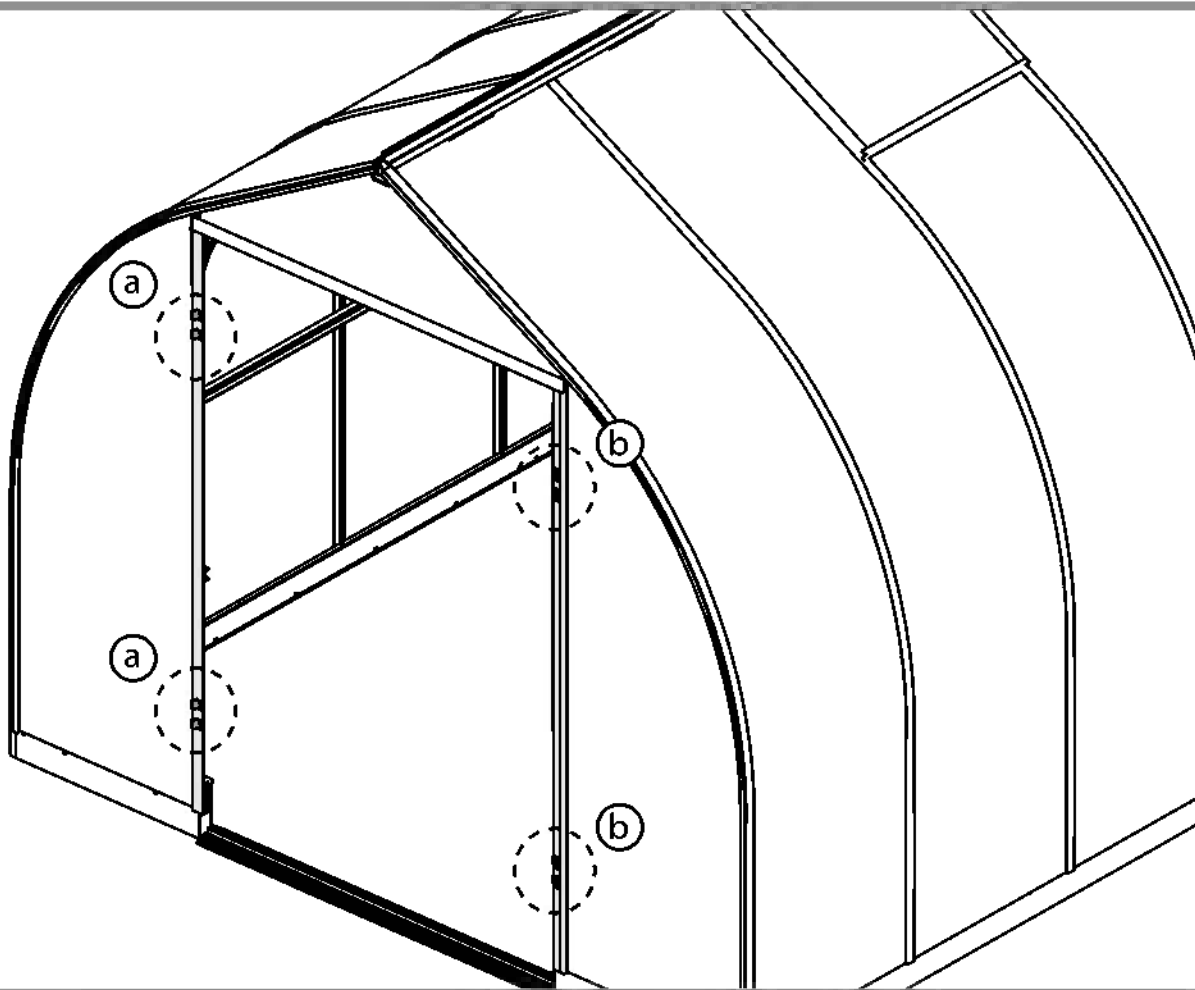
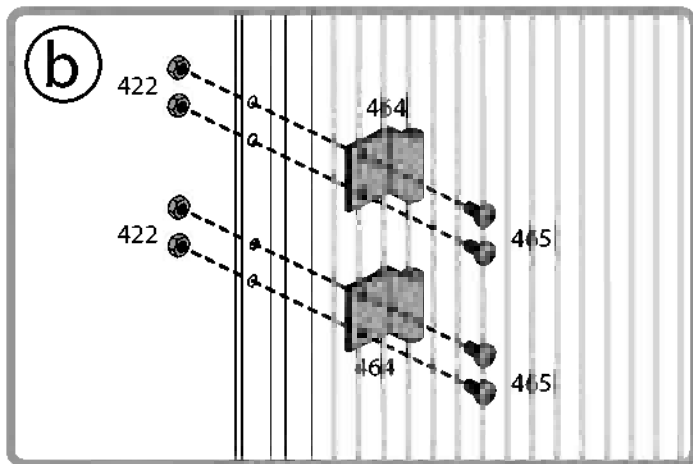
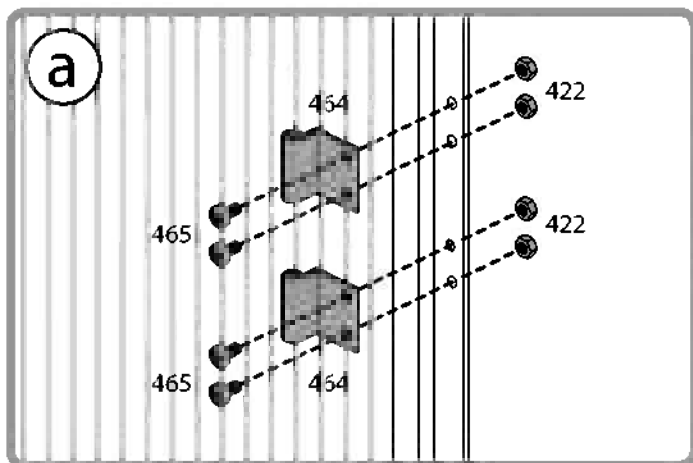
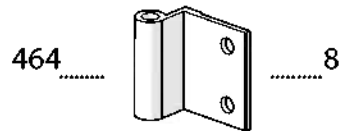
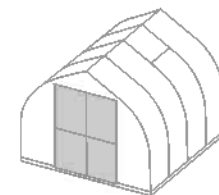

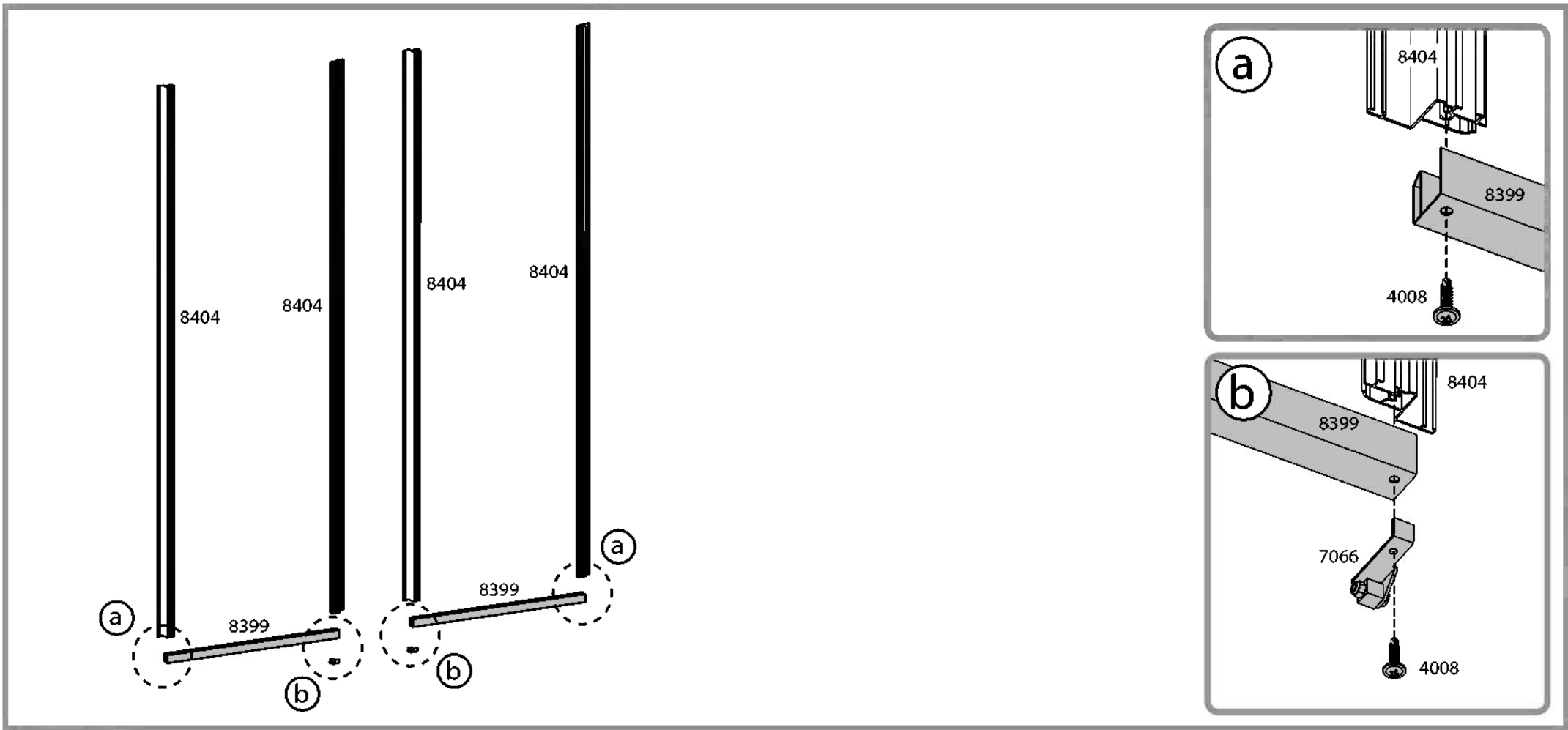
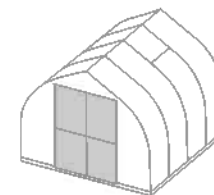

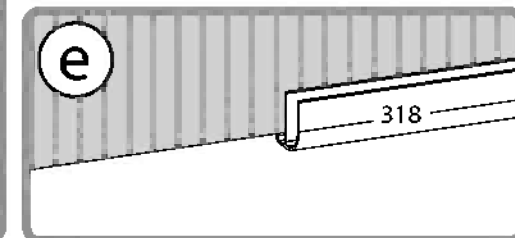
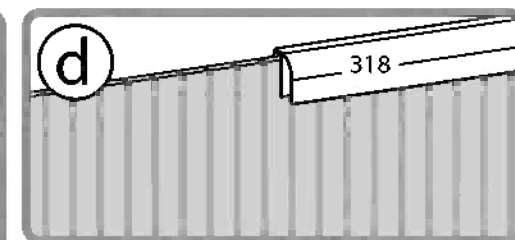
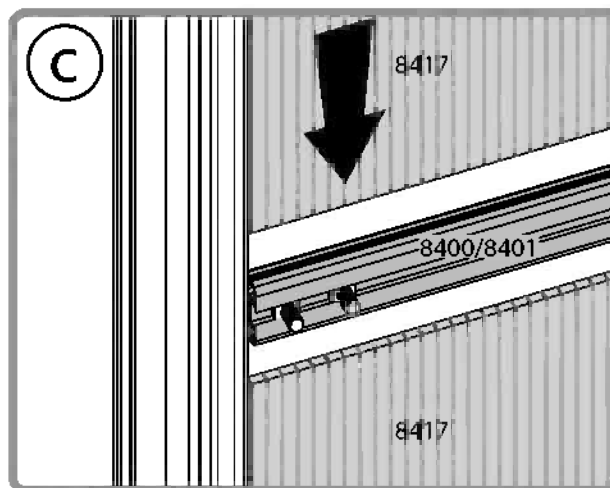
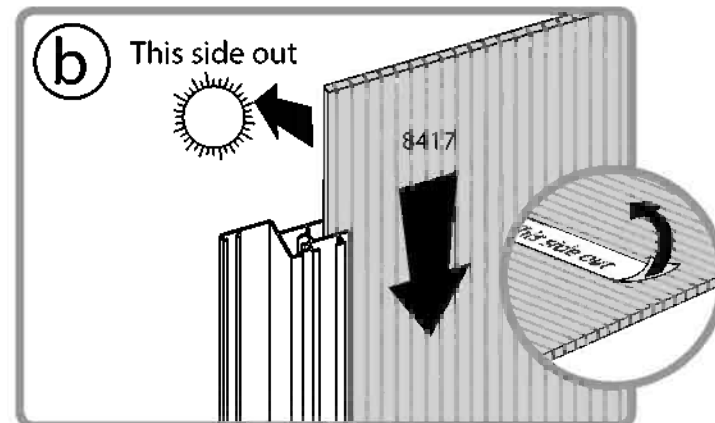
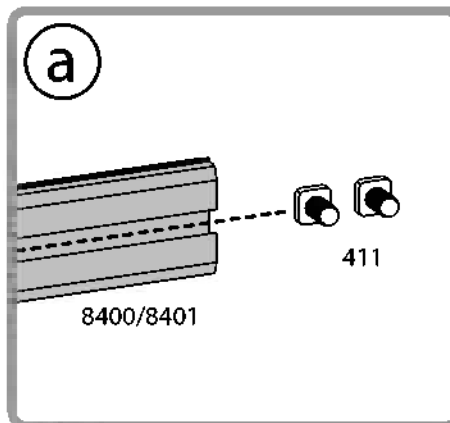
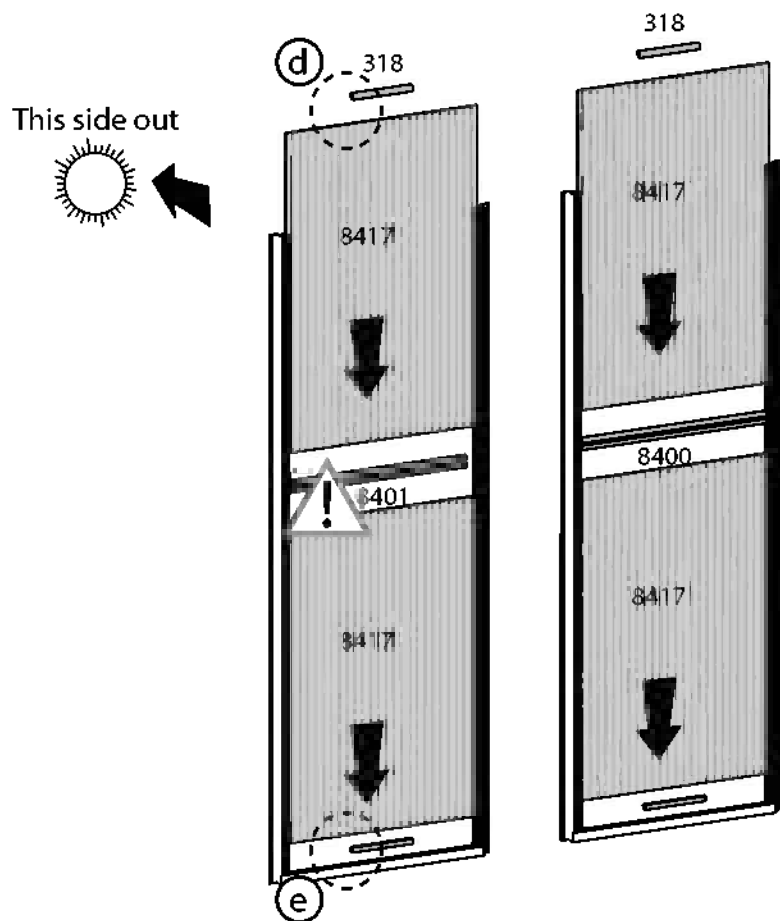
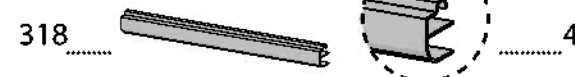
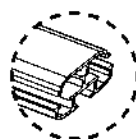
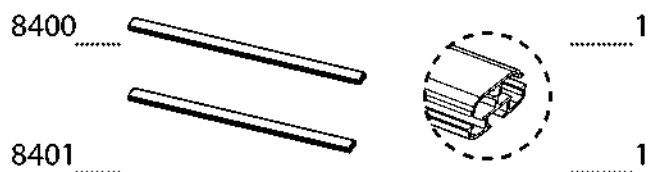
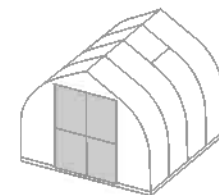

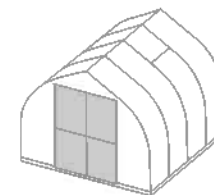

411 19



8399

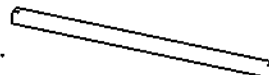

..... 2

4008

..... 4

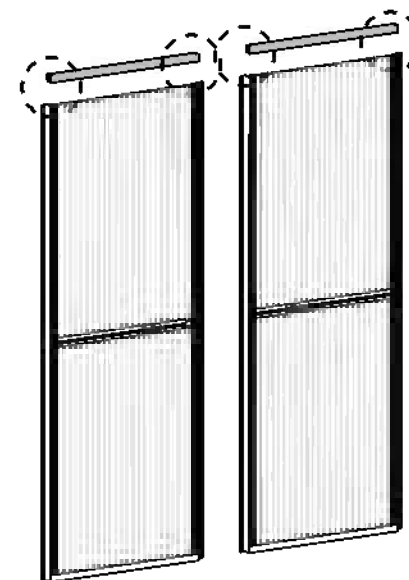
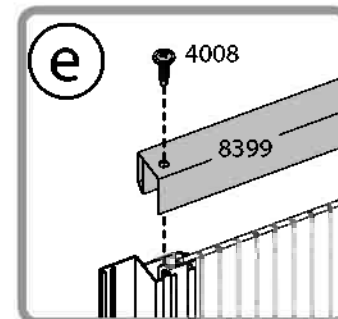
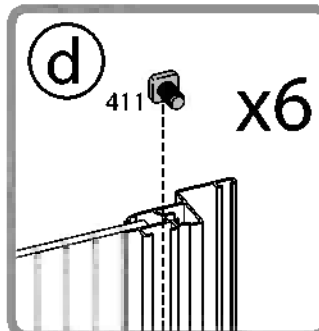
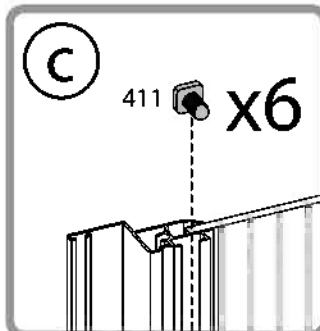
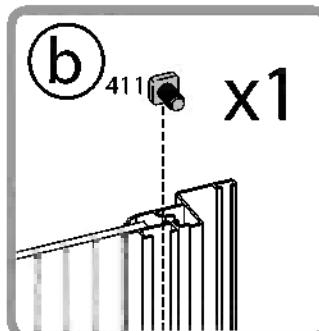
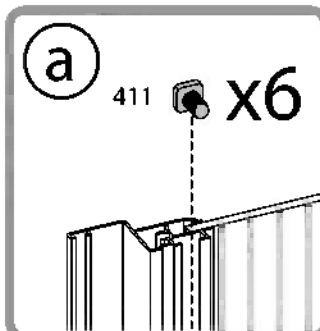
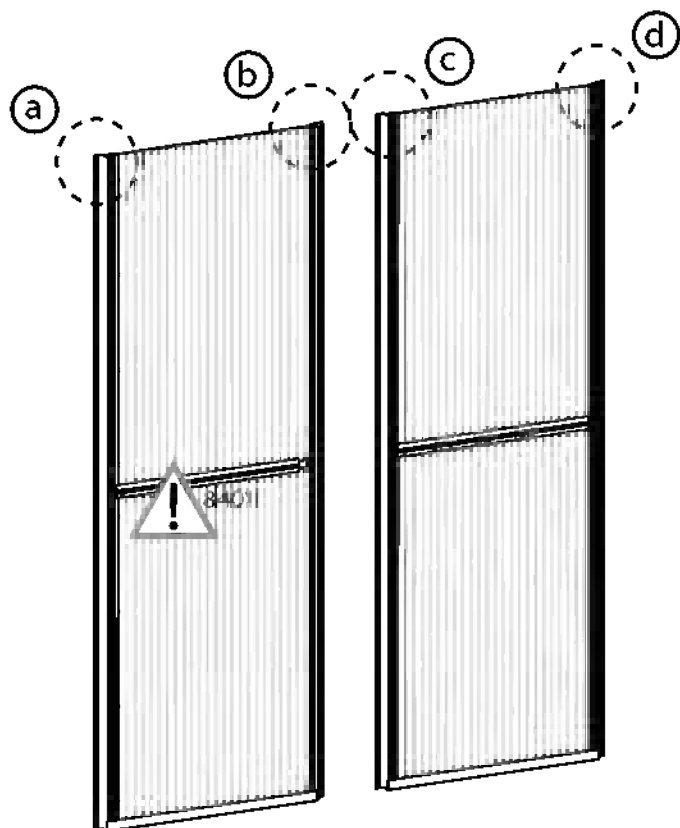

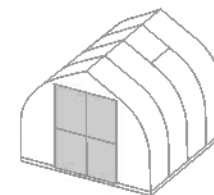

8230 2

7870 2

7871 2

411 4

466 8

a

8230 7871 7870 411 466

8230 7871 7870 411 466

8401

b

c

b

466

c

466

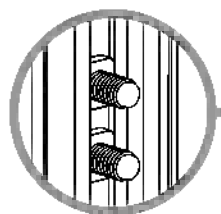
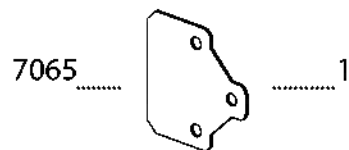
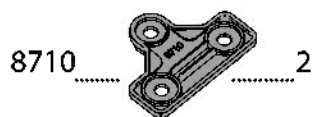
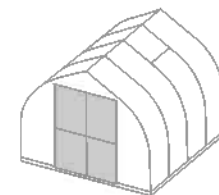

a

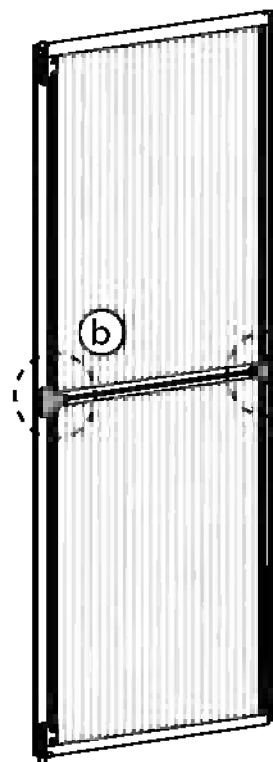
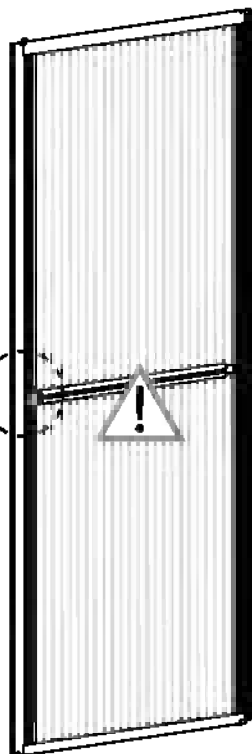



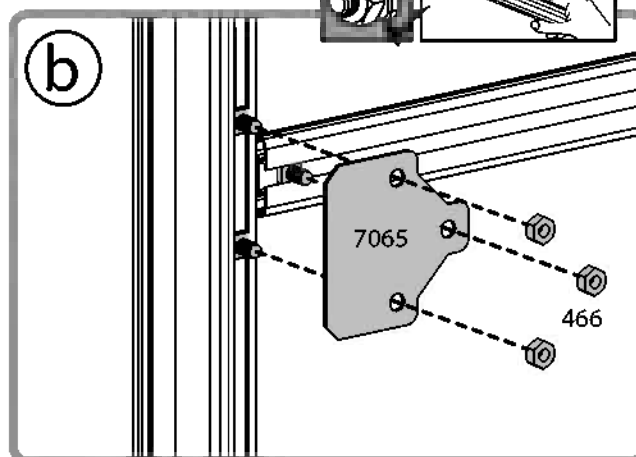
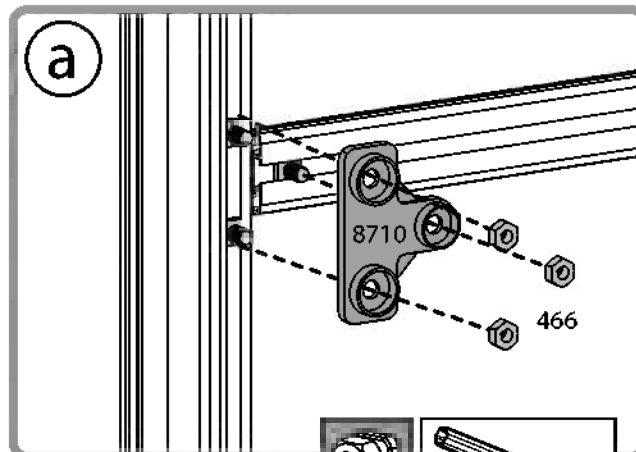
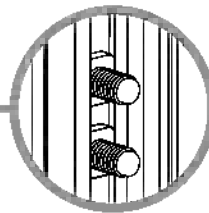
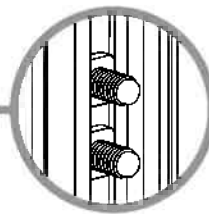

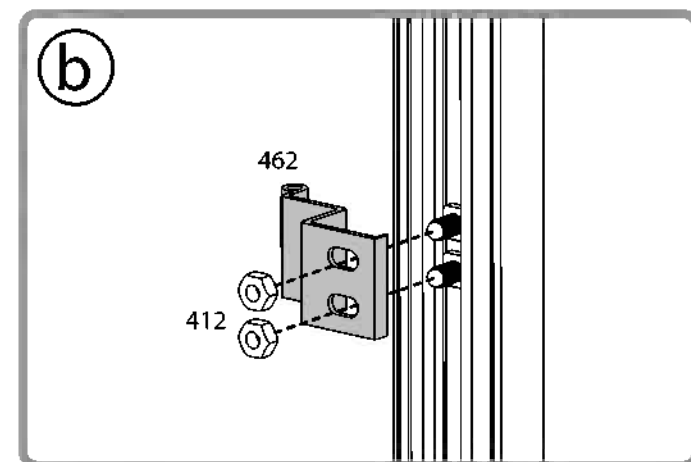
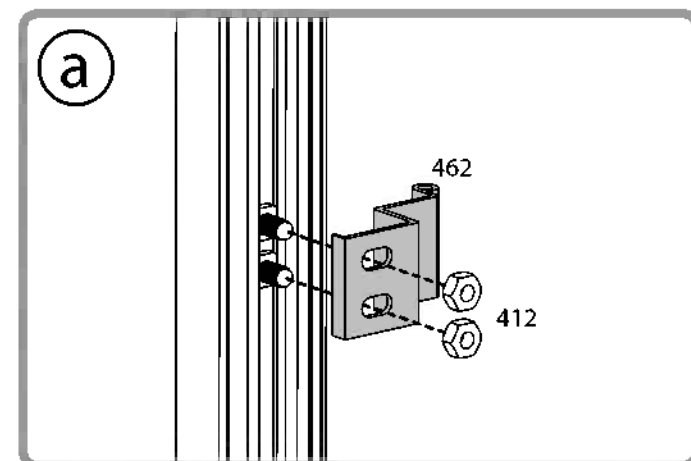
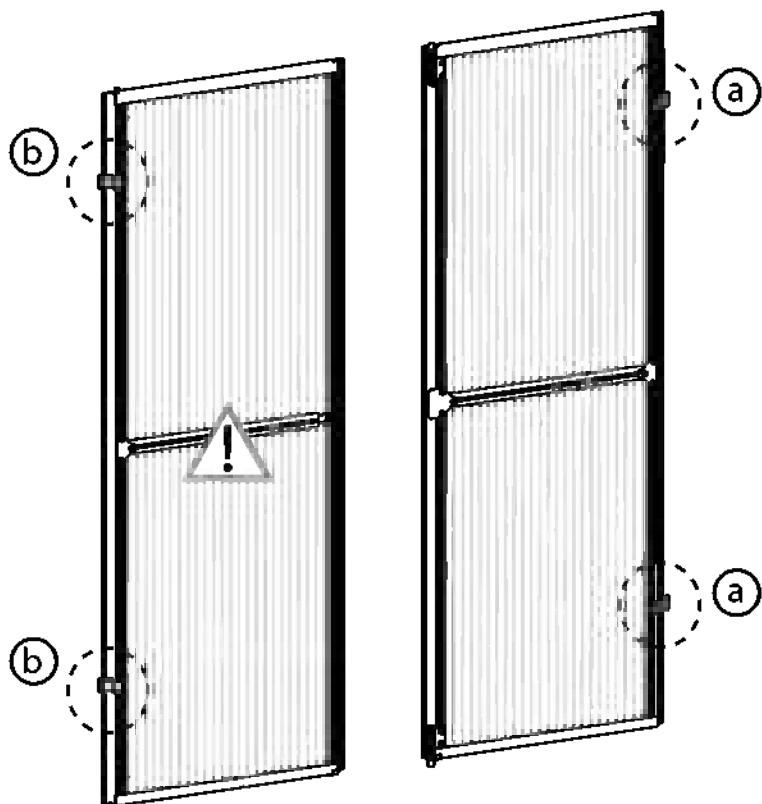
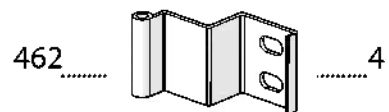
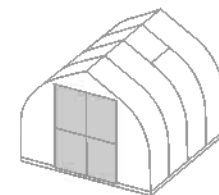
a

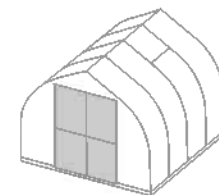

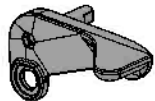
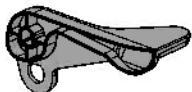
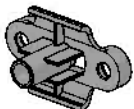
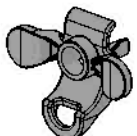



- 7083  1
- 7084  1
- 7085  1
- 7086  1
- 7088  1
- 423  1
- 412  2

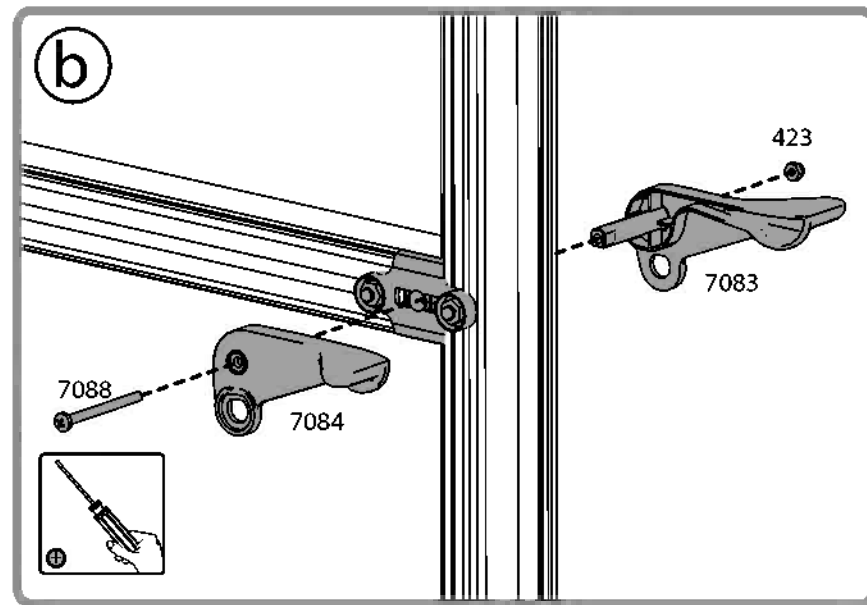
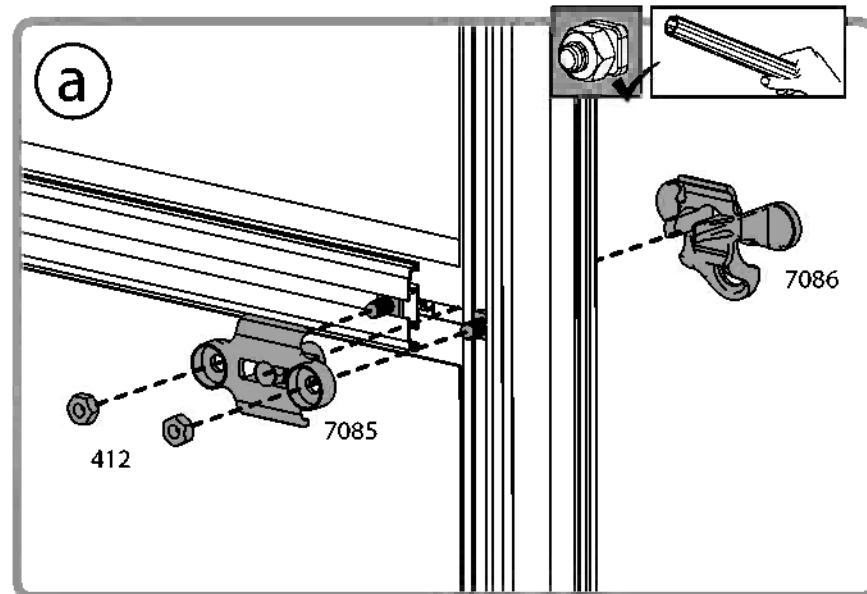
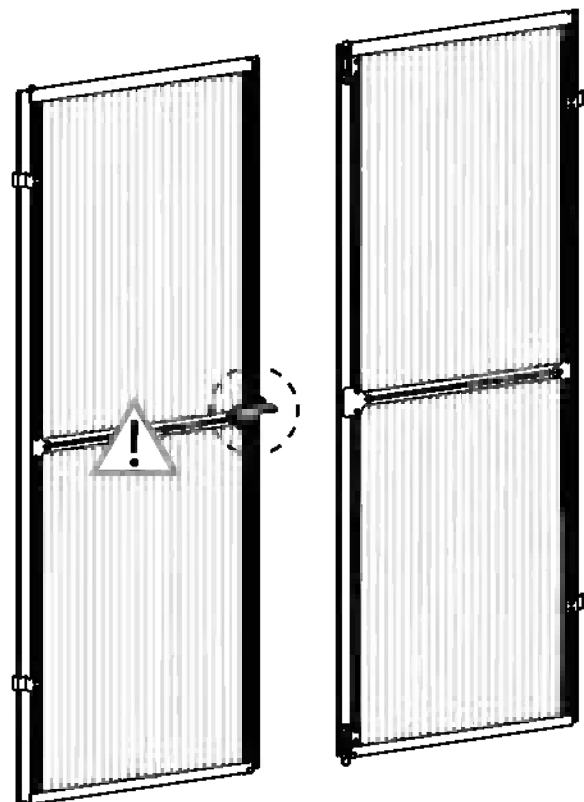

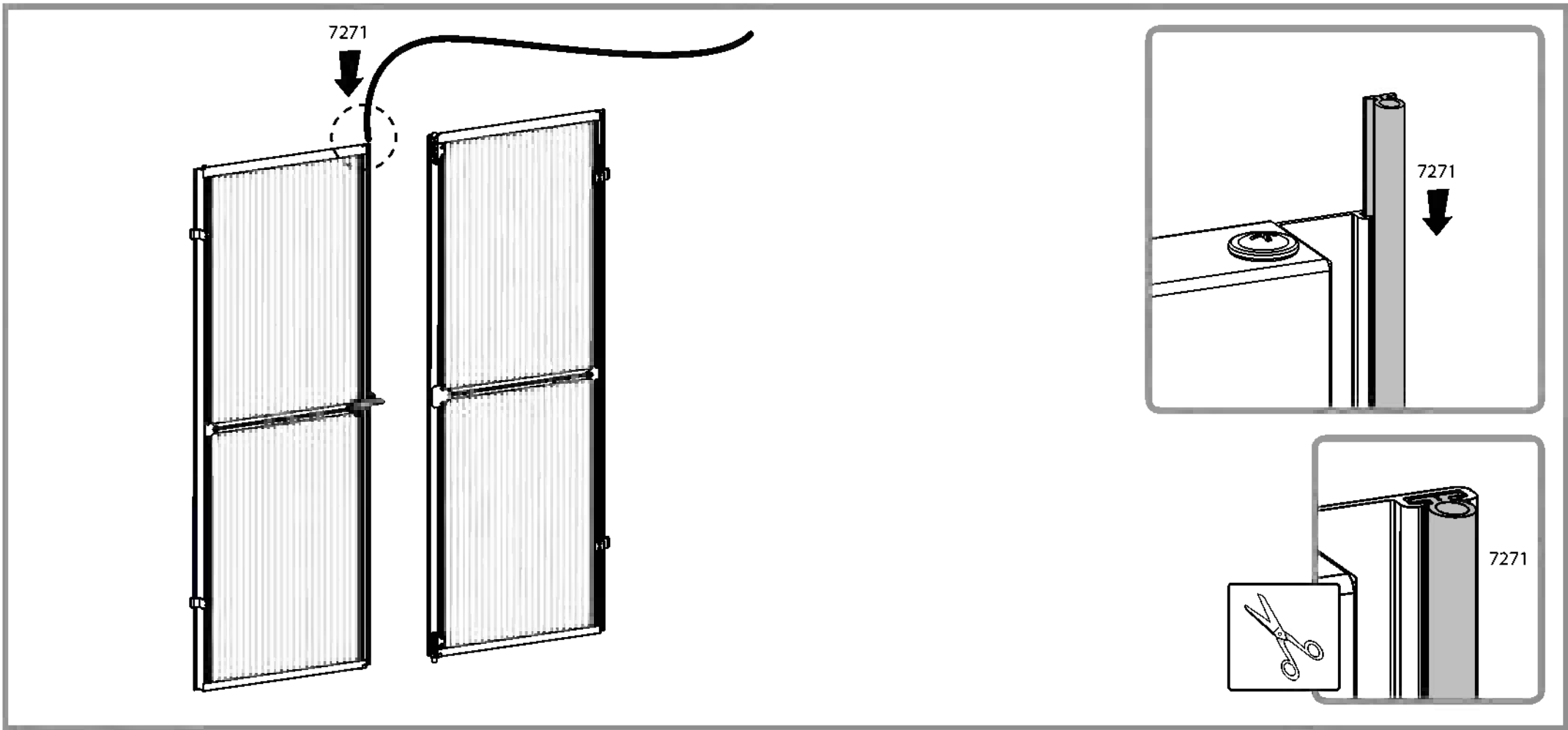
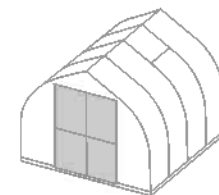

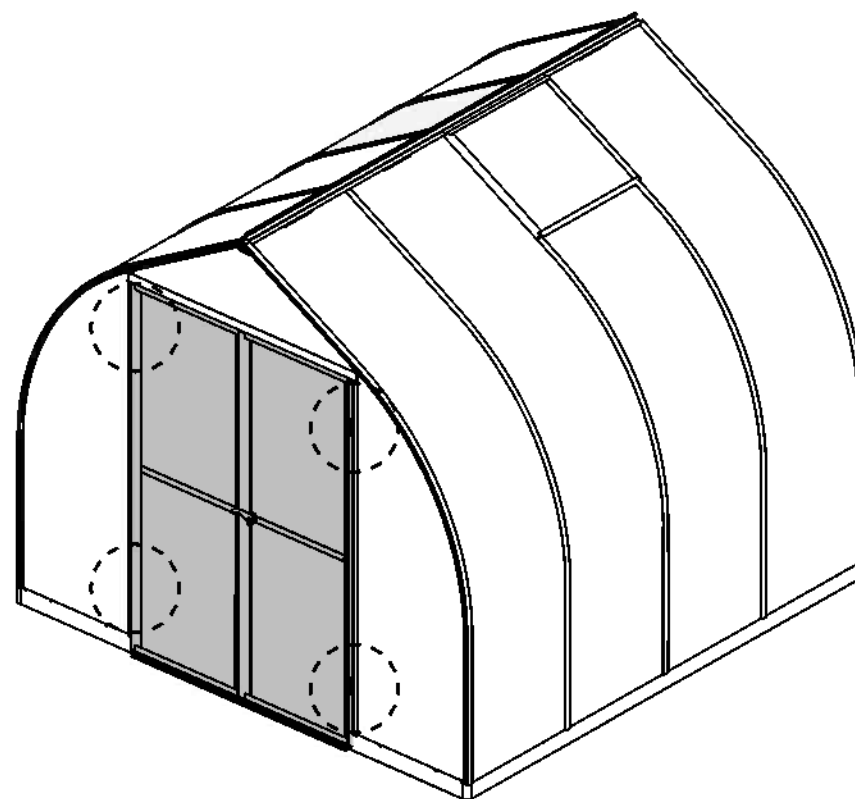
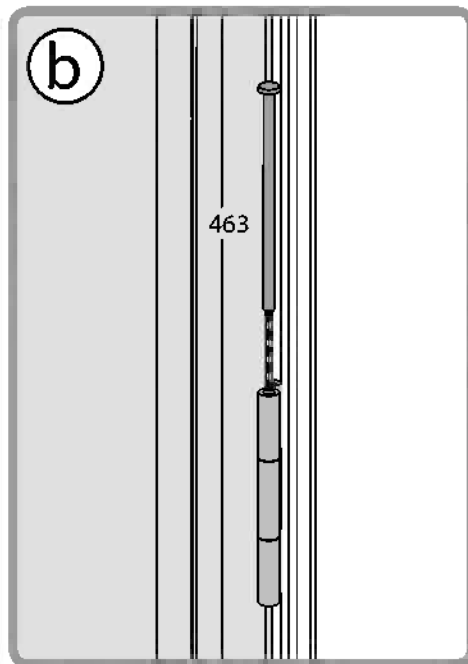
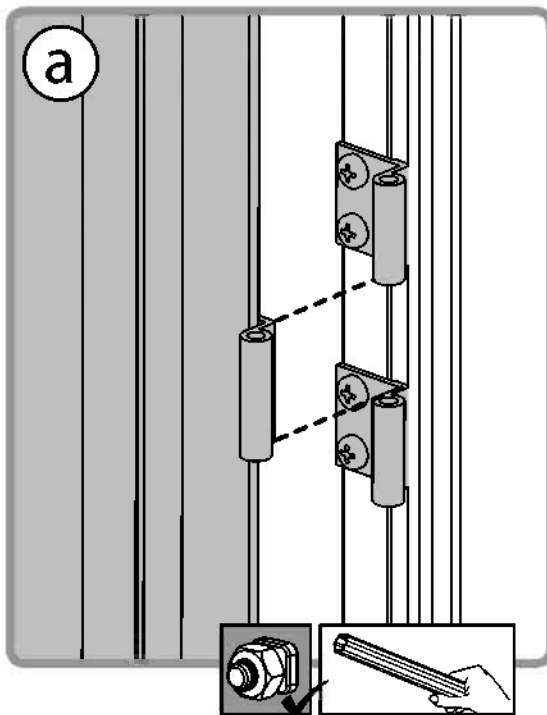
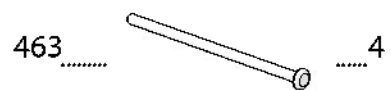
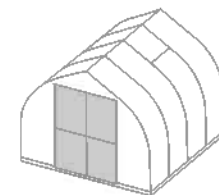

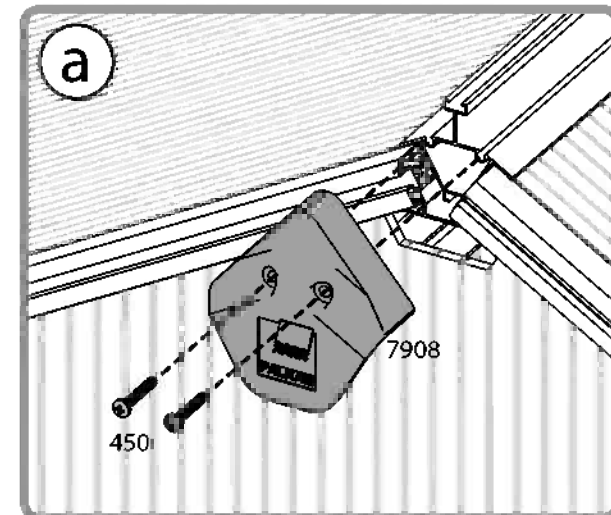
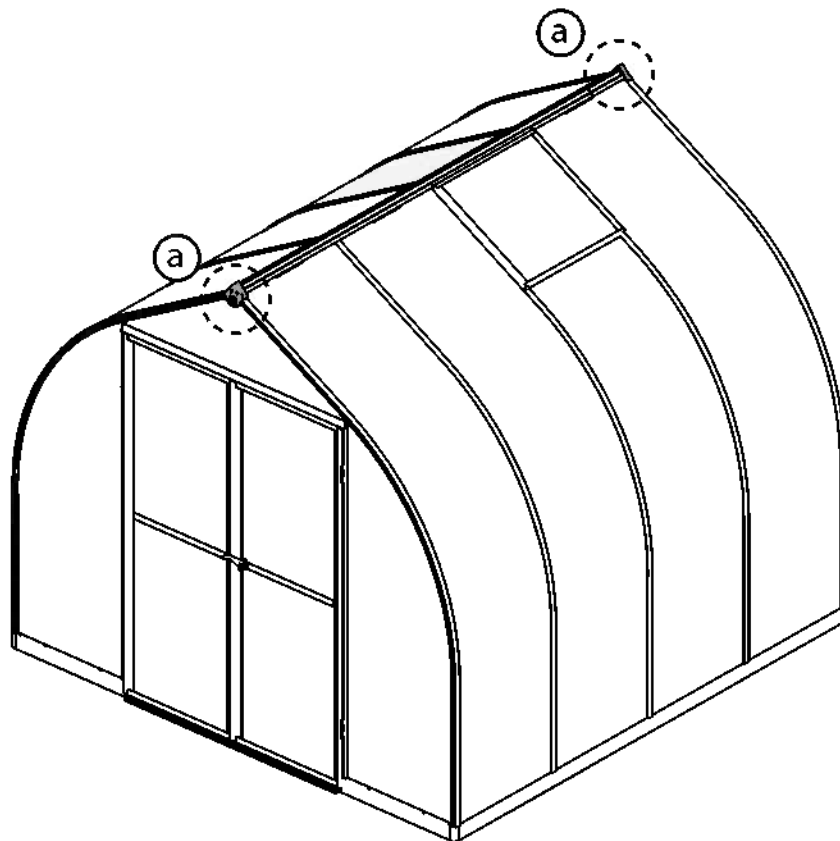
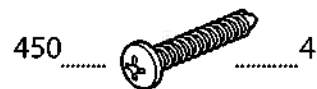
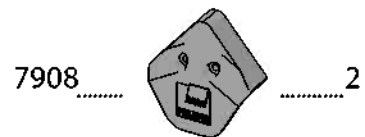
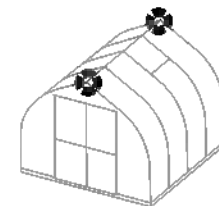

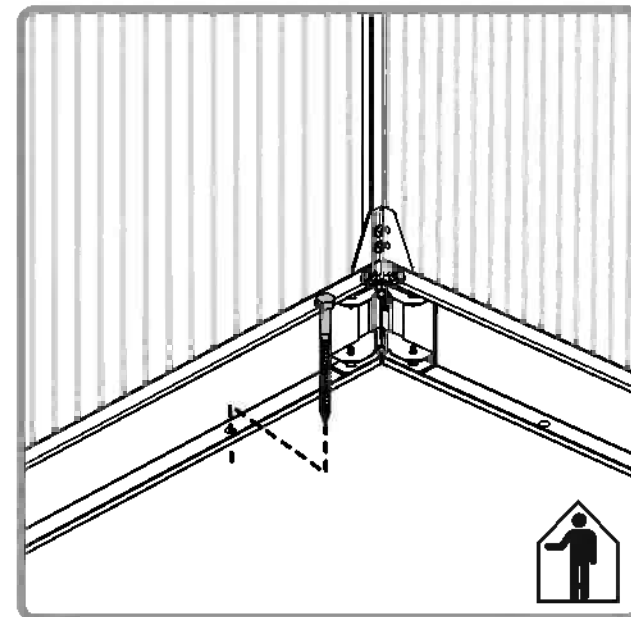
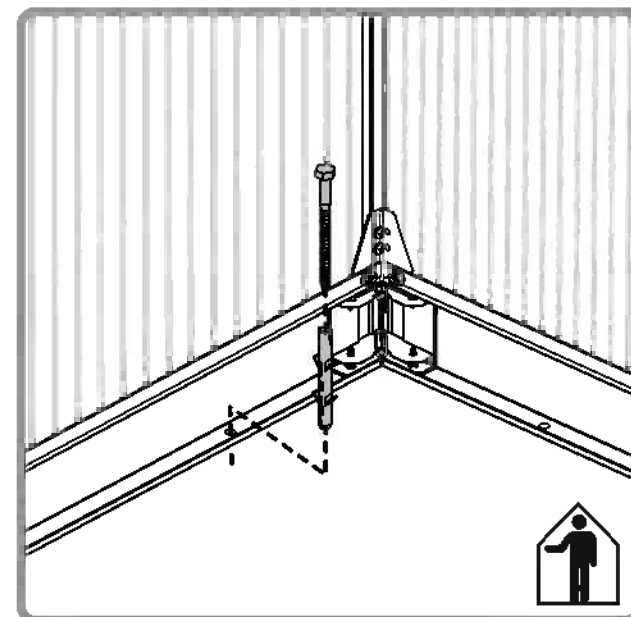
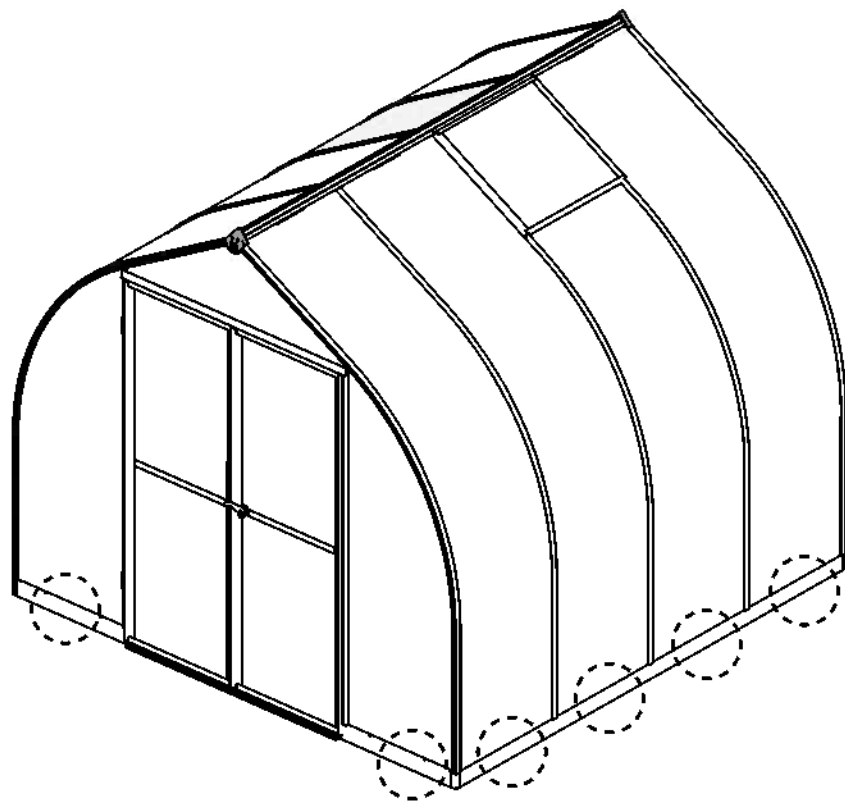
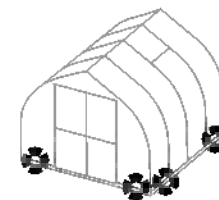

DANCOVER[®]

.com

Contact information

Head office:

Dancover A/S
Nordre Strandvej 119 G
3150 Hellebæk
Denmark

For more information
please visit:
www.dancovershop.com

National contact

Denmark: 70 26 76 20
denmark@dancover.com

UK: 020 8099 7570
uk@dancover.com

Germany: 041 0266 7040
germany@dancover.com

France: 0975 181 800
france@dancover.com

Sweden: 040 233 262
sverige@dancover.com

Finland: 0 931 581 720
suomi@dancover.com

Poland: 22 300 8602
polska@dancover.com

Luxembourg: +49 041 0266 7040
luxembourg@dancover.com

Portugal: 308 800 899
portugal@dancover.com

Spain: 911 436 828
espana@dancover.com

Italy: 02 479 21 198
italia@dancover.com

Switzerland: 0840 000125
schweiz@dancover.com

Austria: 0662 626935
austria@dancover.com

Norway: 231 00 690
norge@dancover.com

Nederland: 0 858 880 524
nederland@dancover.com

Ireland: 0 151 33 003
ireland@dancover.com

Belgium: 0 28 08 08 09
belgique@dancover.com