

**DANCOVER<sup>®</sup>**

**.com**

Manual  
for  
Orangery  
3,2x2,83x2,75m

## Assembly Instructions

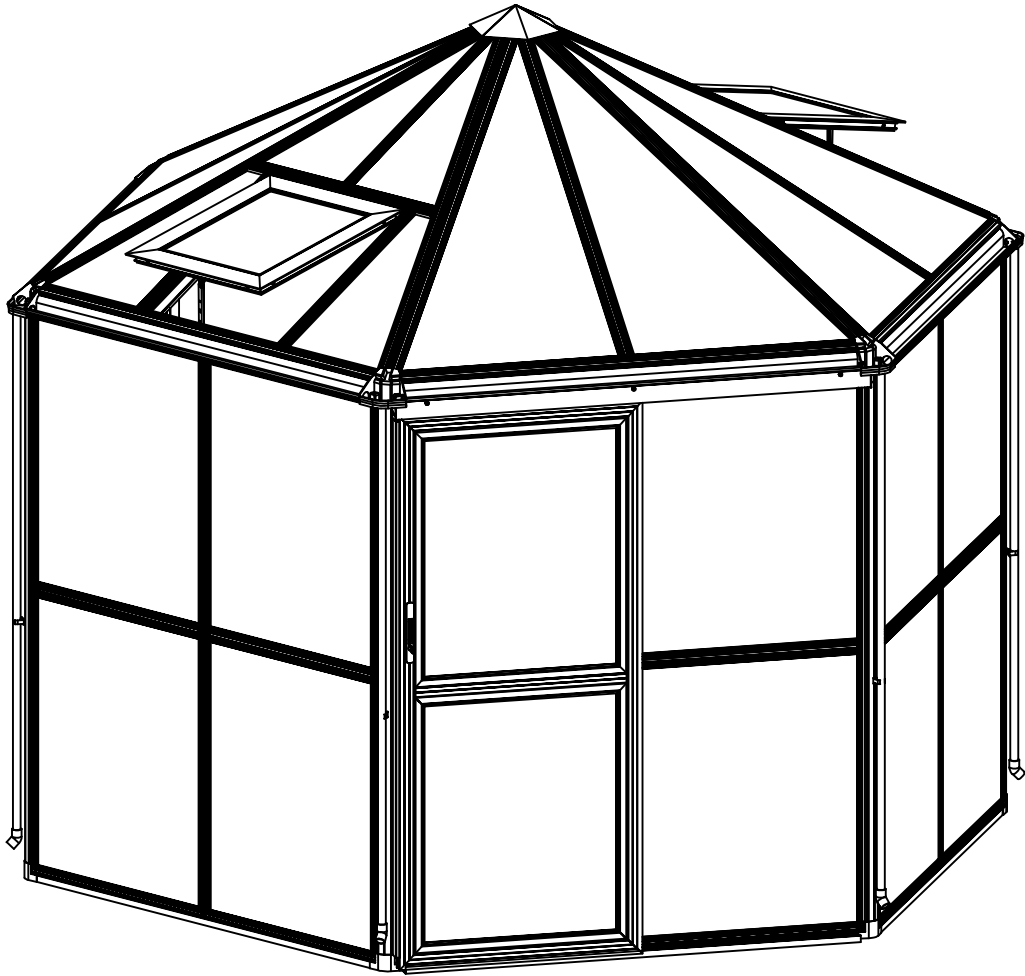

PRODUCT SIZE(LxWxH):320x283x275cm  
PLEASE READ CAREFULLY BEFORE ASSEMBLY

# CONTENTS

1. Assembly Advice .....	Page 2
2. Product Features .....	Page 3 - 4
3. Part Lists .....	Page 5 - 8
4. Roof Vents Assembly .....	Page 9 - 13
6. Doors Assembly .....	Page 14 - 17
7. Base Assembly .....	Page 18 - 19
8. Framework Assembly .....	Page 20 - 40
9. Panels Assembly .....	Page 41 - 51

## Assembly and Maintenance Advice

1. For safety purposes, we strongly recommend that this product is assembled by at least two people.
2. Some components have sharp metal edges. Please be careful when handling metal components. Please wear gloves, shoes and safety goggles during assembly.
3. Lay all of the components on a soft carpet or blanket to avoid any scratches or damages.
4. DO NOT climb or stand on the roof. Heavy articles should not be leaned against the greenhouse.
5. Keep the roof and gutter clear of snow, dirt & leaves. Allowing snow to build up on the roof may damage the product.
6. Unlike steel, if the paint finish is scratched this will not harm the aluminium underneath.
7. When your product needs cleaning, use a mild detergent solution and rinse with cold clean water. Do not use acetone, abrasive cleaners or strong detergents to clean the panels.

Component required but not provided:

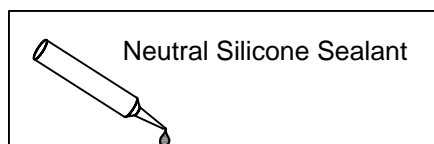

Tools Provided:

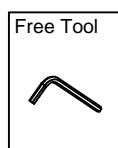
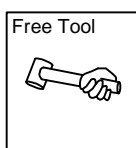
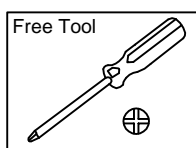
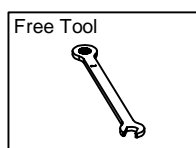

Tools Required when Assembly (Not Provided)

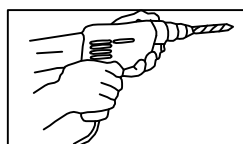
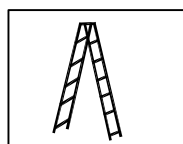
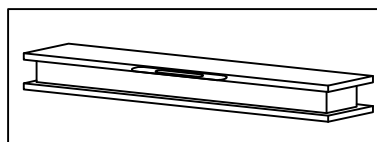
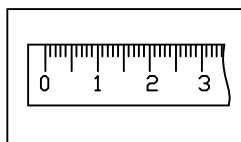
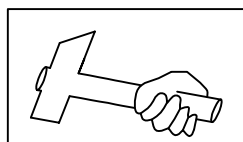
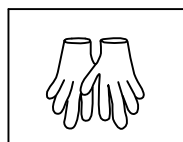

Assembly at least by two Persons



# Functions and Features:

1. Compared with traditional greenhouses, this exciting new product features many significant improvements. The hollow box profile aluminium framing is much stronger than other greenhouses and it can withstand much greater pressure.

Wind resistance up to 12th typhoon (40M/S or 120KM/H). Weight Support 80KGS/M2, Snow load capability over 40CM.

Traditional Greenhouse

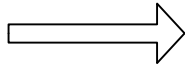
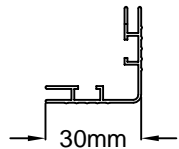

New Hexagon Greenhouse

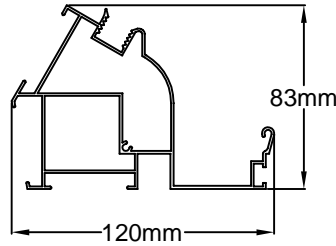

Gutter Profile

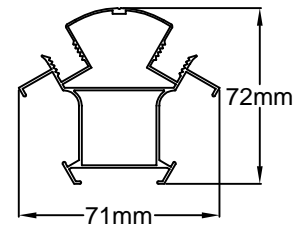

Post

2. A great improvement for this new greenhouse is bigger bar capping and thicker connectors, which are much neater and stronger. Another benefit is that these greenhouses can be glazed with glass or polycarbonate of varying thicknesses.

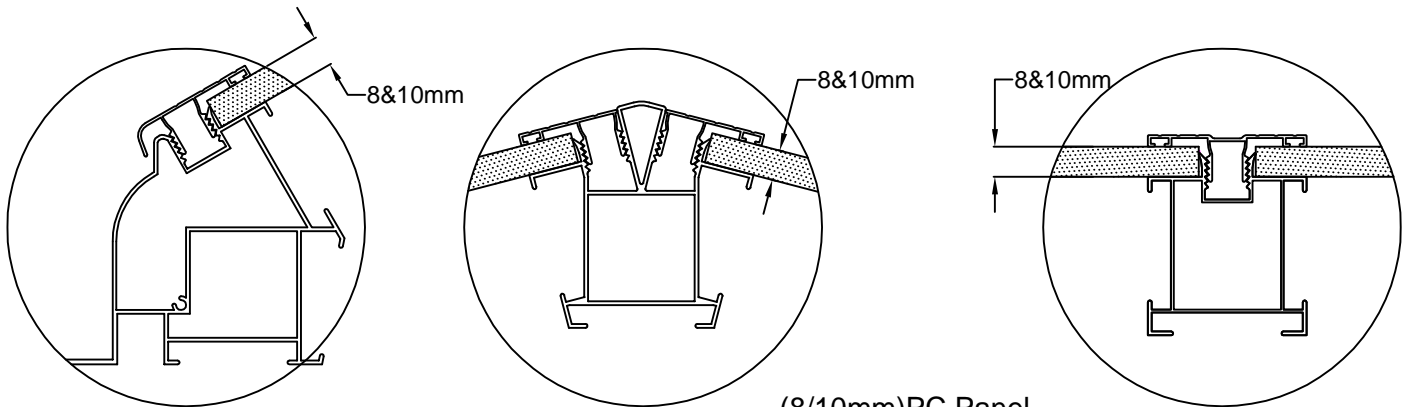

(8/10mm)PC Panel

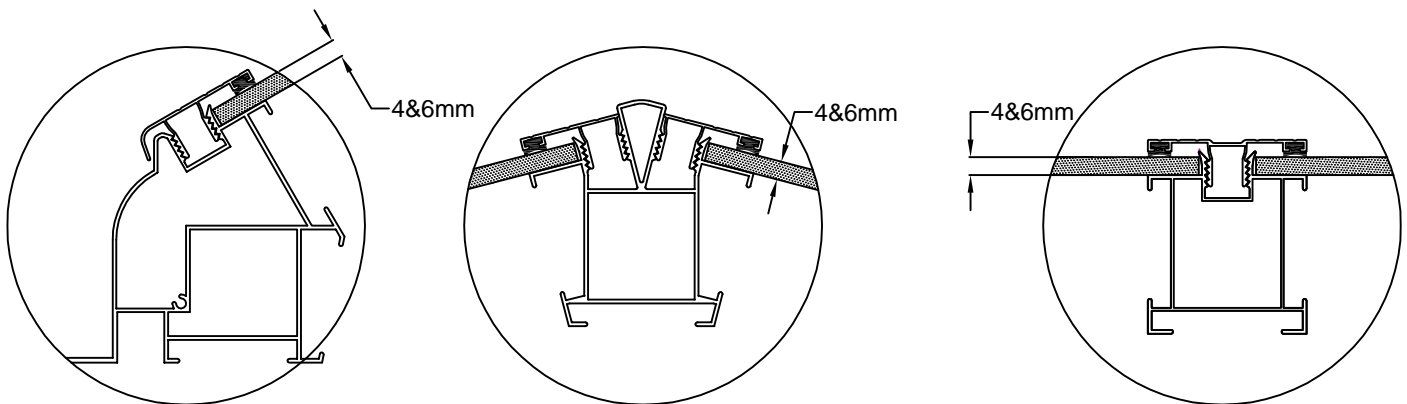

(4/6mm)Glass Panel

\* If you are glazing this greenhouse with glass you will need to slide the rubber gaskets (provided) into the bar capping.

3. Base anchor brackets are included as standard with expanding bolts to ensure a secure fixing into concrete or paving. Alternatively, you can use the brackets to fix into a timber base with wood screws.

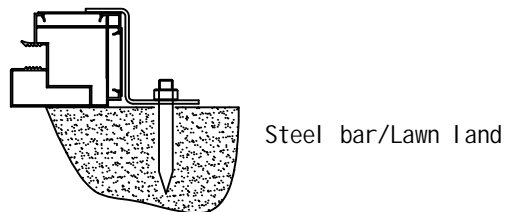
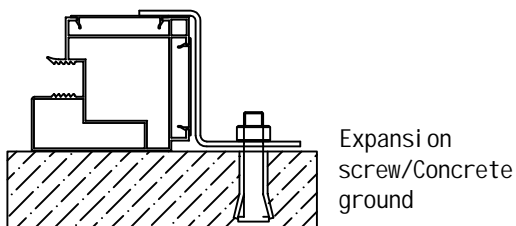

4. Our unique frame connectors (2.5mm thick) make much stronger joints than conventional greenhouses.



5. The strong two part eaves beam includes an integral gutter. Downpipes are also included as standard so you can collect rainwater.

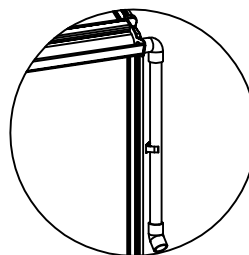



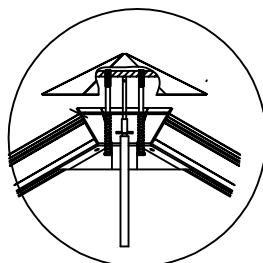



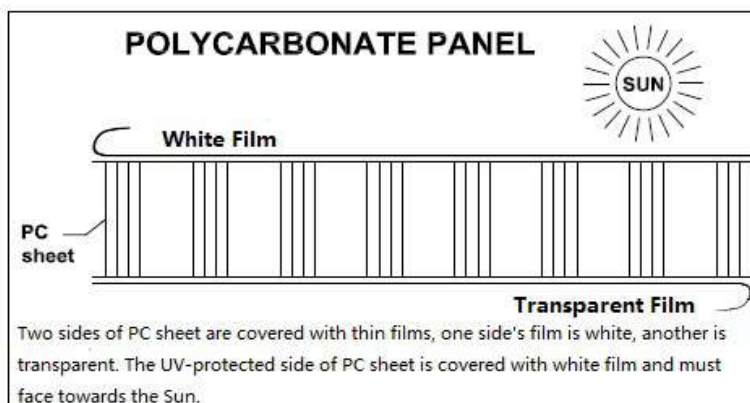





6. Automatic Roof Cap. The roof cap can open or close automatically.











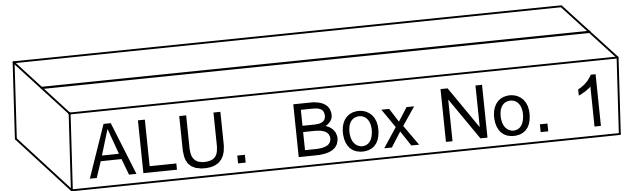



7. Remove approximately 2 inches of film from all sheet edges before installing and remove all film immediately after the construction is completed. Please ensure that the side with the white film faces outwards.



# GH152010





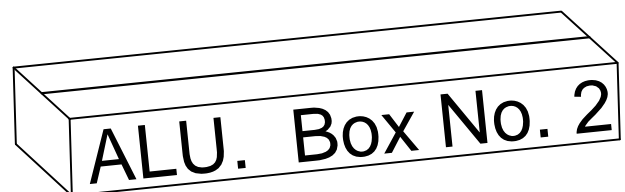

PART	NO	QTY
	L03A	6
	L11E	1
	L11F	4
	L11G	4
	L12K	11
	L16A	4
	L16B	4
	L17	1
	L19B	2
	L20	2
	L22	2
	L23C	35
	L25E	2









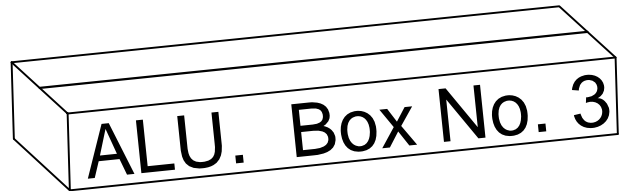

PART	NO	QTY
	L02B	4
	L09	6
	L11A	11
	L11B	12
	L18A	1
	L18C	1
	L23D	44
	L24A	6
	L24D	4
	L25A	4
	L25C	2
	L25D	4





















# GH152010



PART	NO	QTY
	L02A	6
	L04A	1
	L12A	6
	L14	1
	L23A	14
	L24C	8











PART	NO	QTY
	L01A	6
	L11D	10
	L11H	4
	L11J	4
	L18D	2
	L19A	4
	L25B	4
	J06	6

PART	NO	QTY
	W03	2
	W06	2
	W08	2
	W11	12
	D	2
	Z	4
	S01 M6X12	19
	S02 M8X35	2
	M01 M6	3
	M02 M8	2
	M03 M6	19
	Z01 Ø4X16	6
	Z02 Ø4X16D	4
	Z03 Ø4X10	8
	Z04 Ø4X50	4

PART	NO	QTY
	J01	6
	J02	6
	J07	6
	J08	6

PART	NO	QTY
	J11	12
	Z05	12
	J12	12





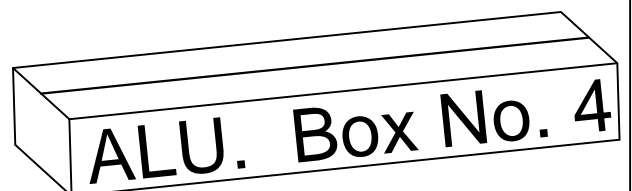



PART	NO	QTY
	W05	11
	S03 M8X60	11

PART	NO	QTY
	W01	1
	W02	1
	W04	1
	W09	2
	S04 M8X150	2
	GM80003	1









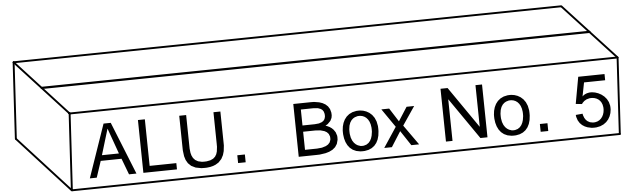



# GH152010







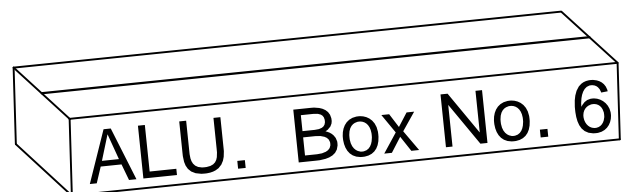

PART	NO	QTY
	L02C	2
	L02E	2
	L02K	11
	L07	6
	L12B	4
	L12C	2
	L12D	4
	L23B	12











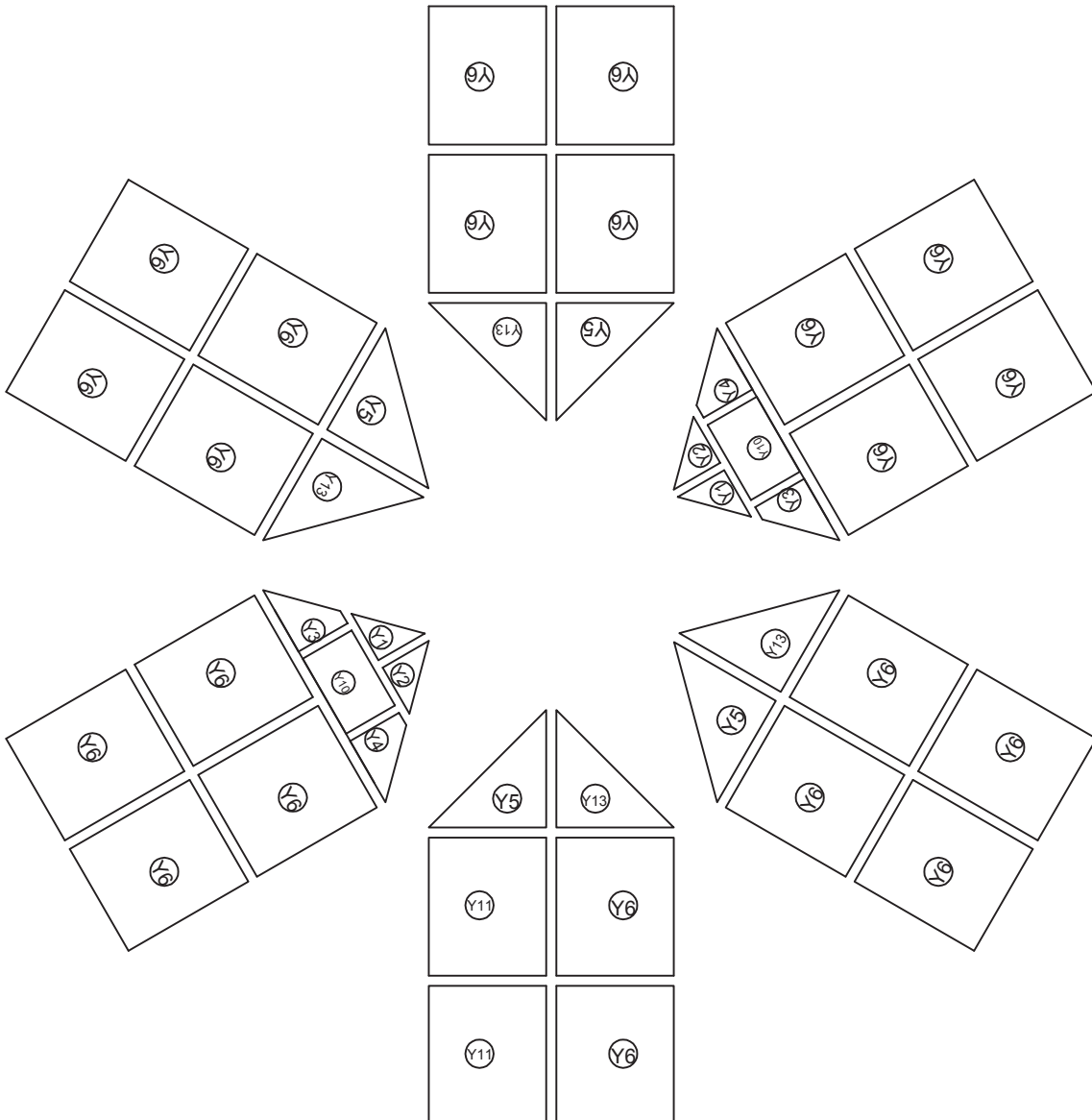
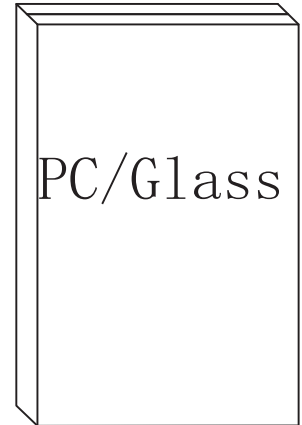

PART	NO	QTY
	L02D	4
	L08A	5
	L10	1
	L24B	4
	A	6
	B	6
	J	12
	K	48
	N	4



# GH152010

PART	NO	QTY
	Y1	2
	Y2	2
	Y3	2
	Y4	2
	Y5	4
	Y6	22
	Y10	2
	Y11	2
	Y13	4



PART	NO	QTY
	L11F	4
	L11G	4
	L19A	4
	L19B	2
	L20	2
	J	8
	W06	2
	Z03	4
	Ø4X10	
	Z02	4
	Ø4X16D	
	Y10	2

# Windowx2pcs

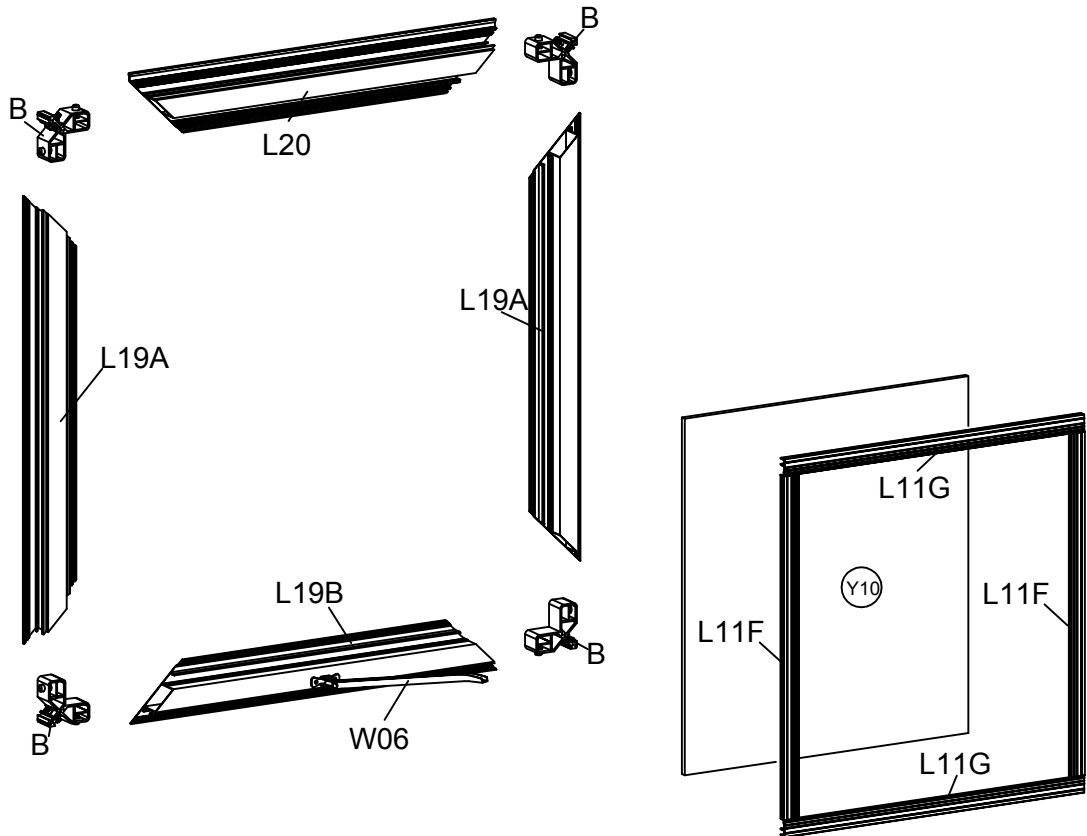

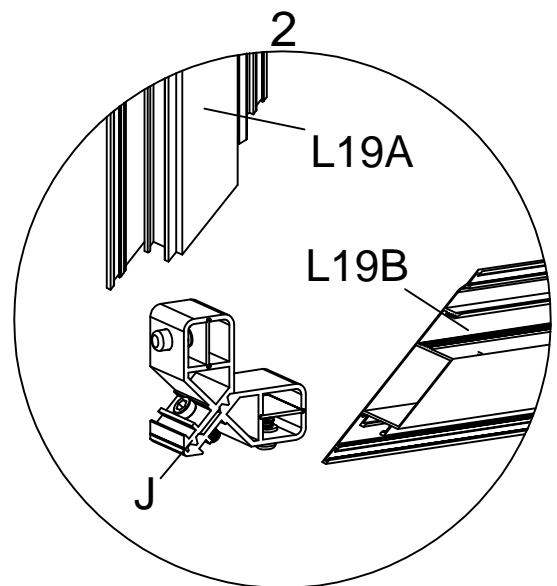
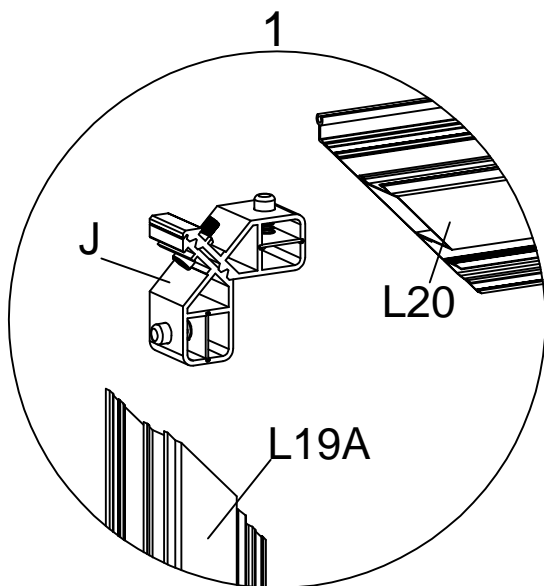
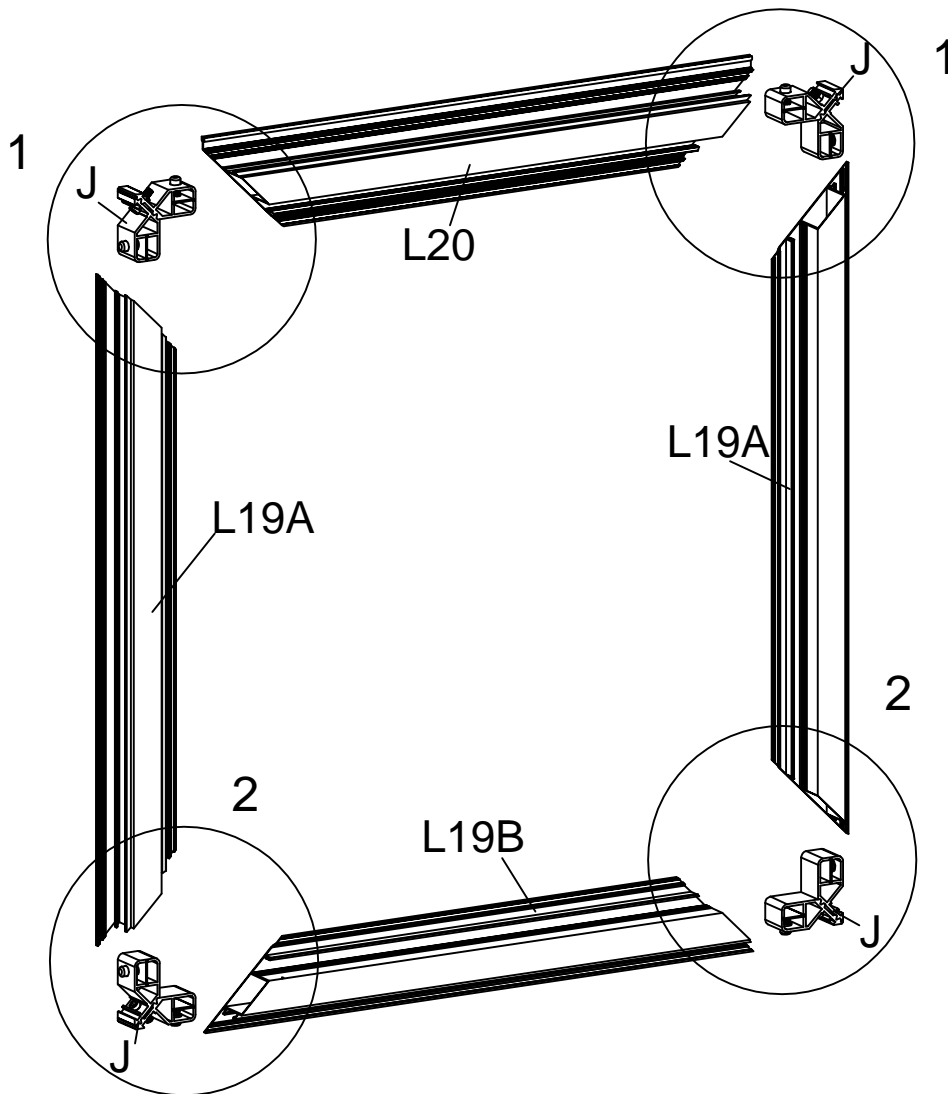

Push down the button on connector J before inserting it into the end of the frame profile.

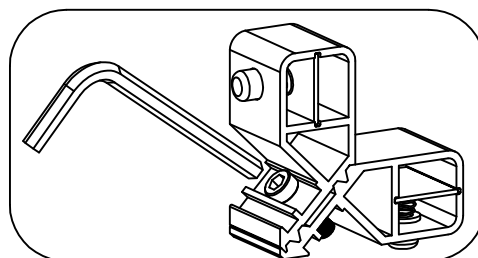

After connector J has been fitted, use the hole in the profile to tighten the connector in place.

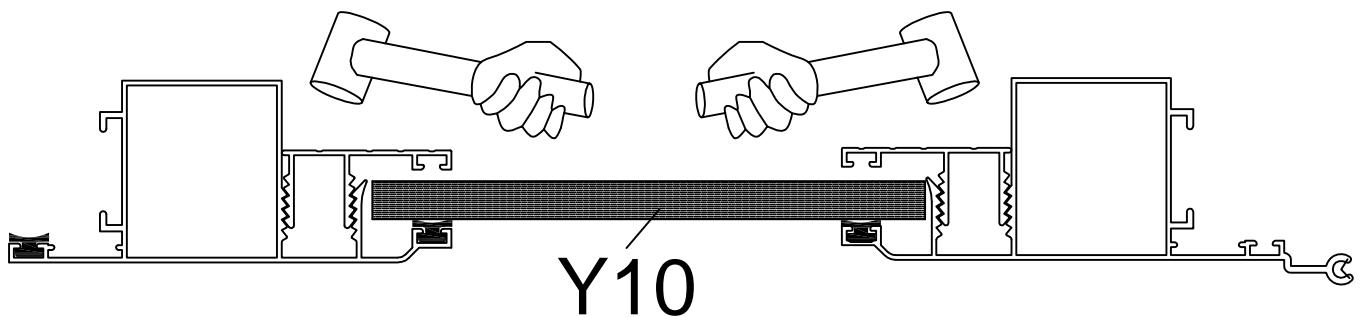
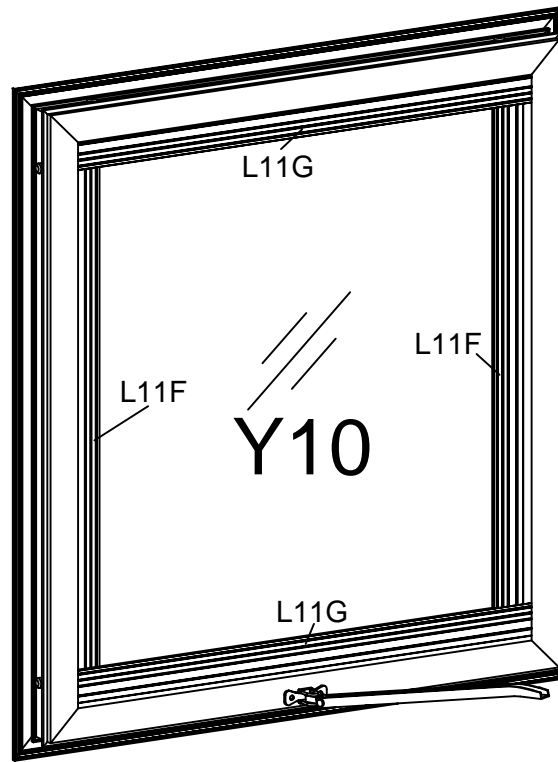



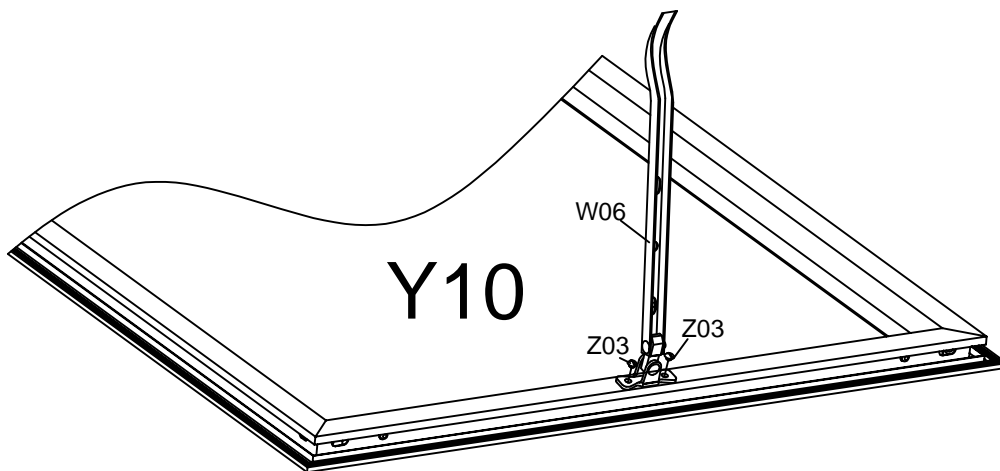
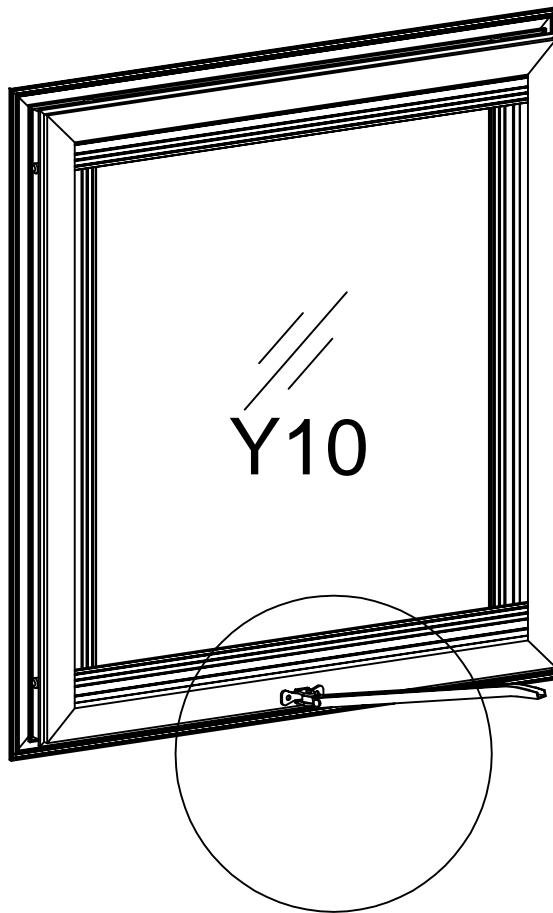



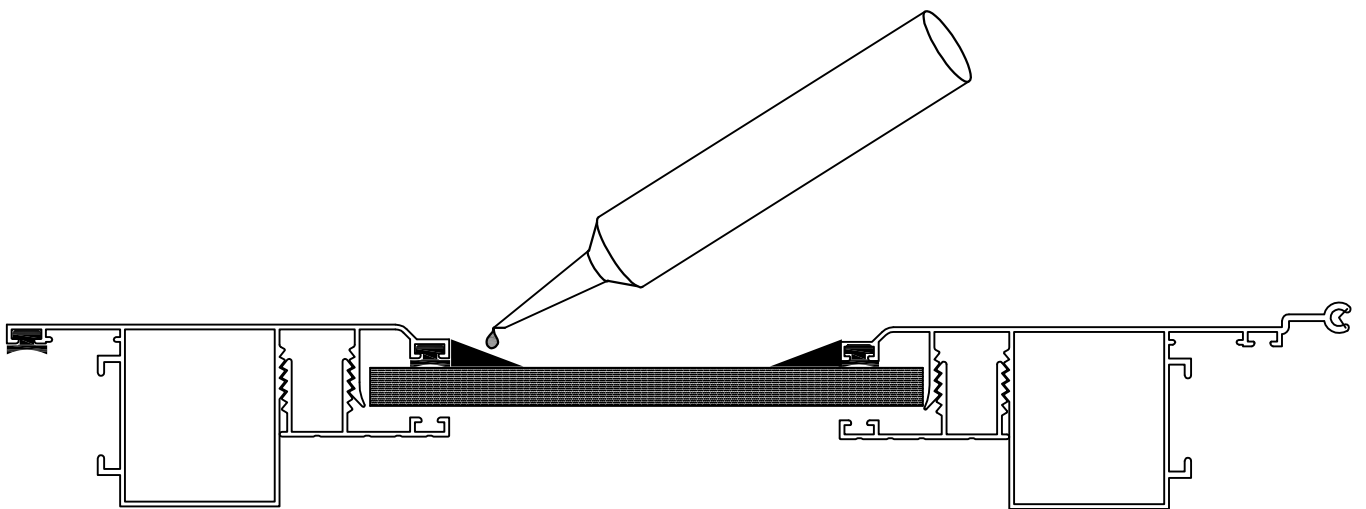
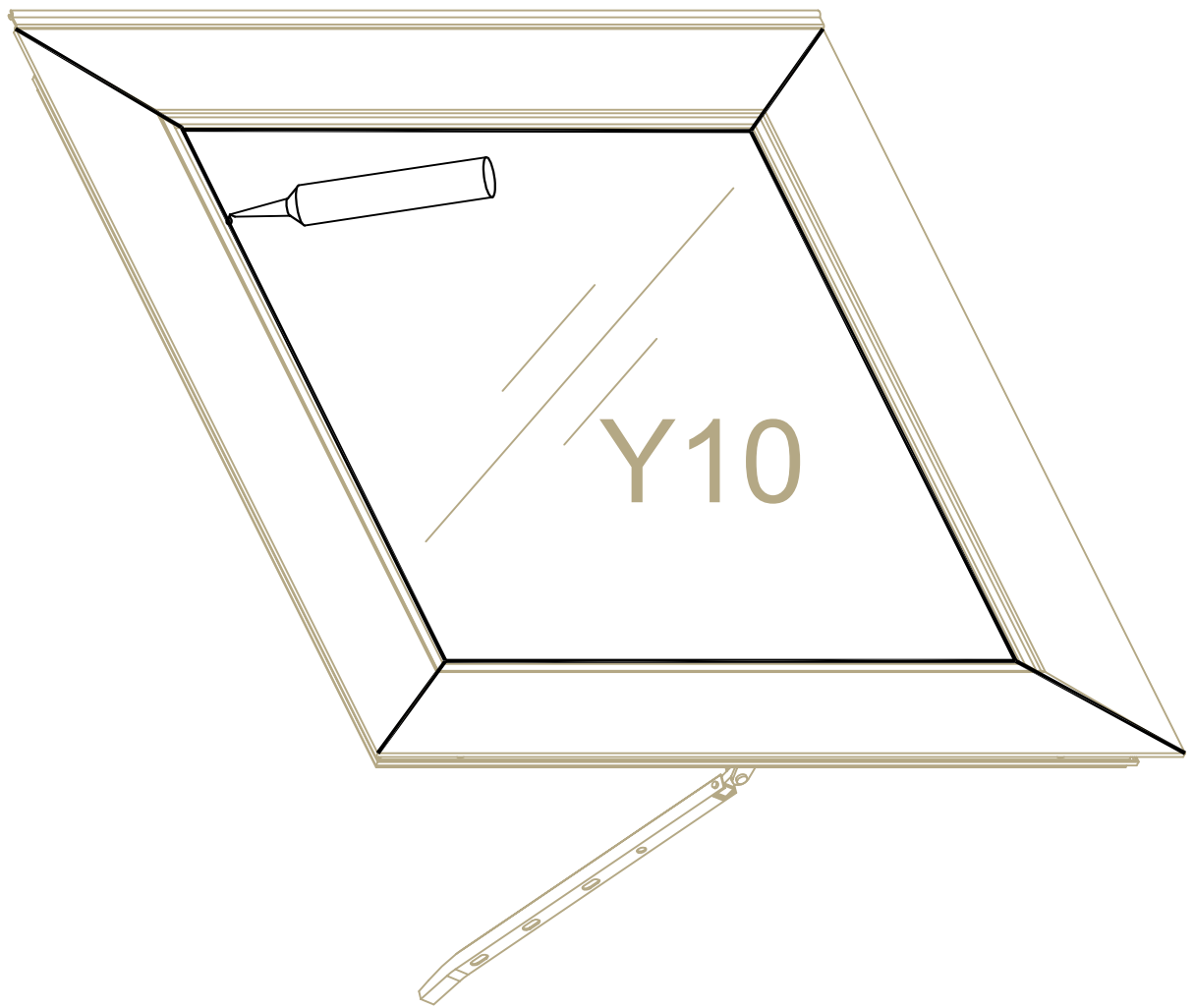







First the glazing panel Y10 should be loosely retained by the bar capping profiles L11F and L11G. Next tap the bar capping gently into position with a rubber mallet.



Fix the W06 vent handles using Z03 screws.



Fill the gap with silicone sealant on 4 sides to avoid any leaking.

PART	NO	QTY	PART	NO	QTY	PART	NO	QTY
	L16A	4		J	4		Y11	2
	L16B	4		D	2			
	L17	1		S02 M8X35	2			
	L18A	1		M02 M8	2			
	L18C	1		Z04 Ø4X50	4			
	L18D	2						
	L11H	4						
	L11J	4						

# Door

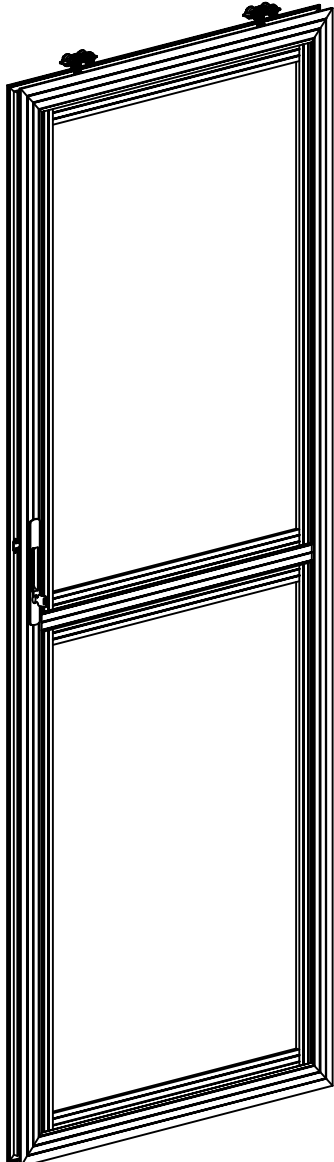



Put L16A into L17 and L18D and put L16B into L18A and L18C, then assemble the door frames using connector J, as shown in the sketches below.

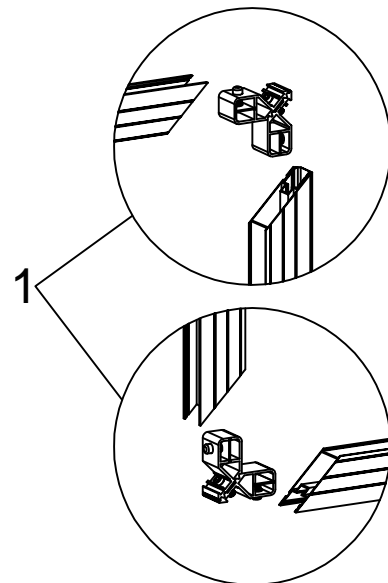
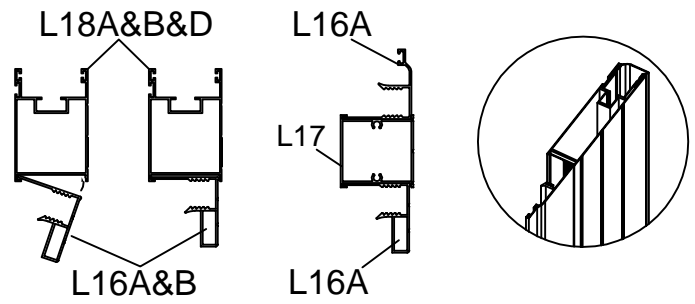
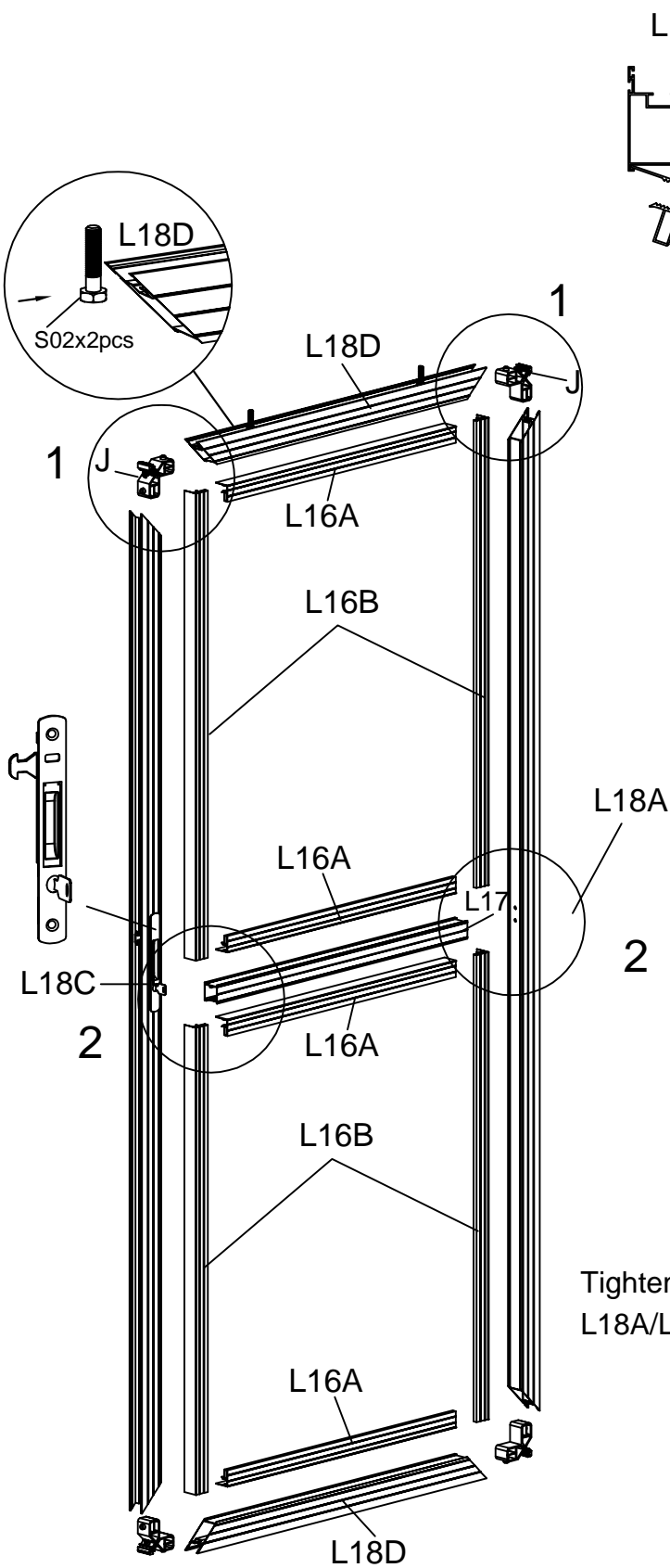

Push down the button on connector J before inserting it into the end of the frame profile.

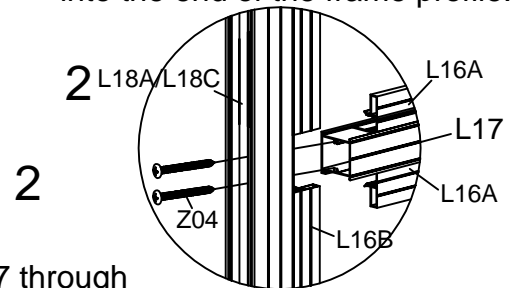

Tighten L17 through L18A/L18C with Z04.

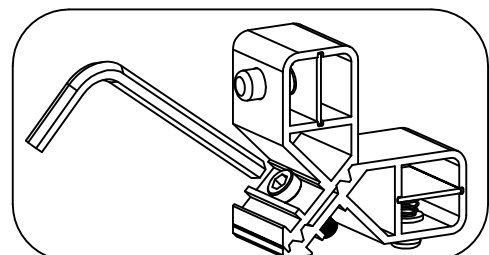

After connector J has been fitted, use the hole in the profile to tighten the connector in place.

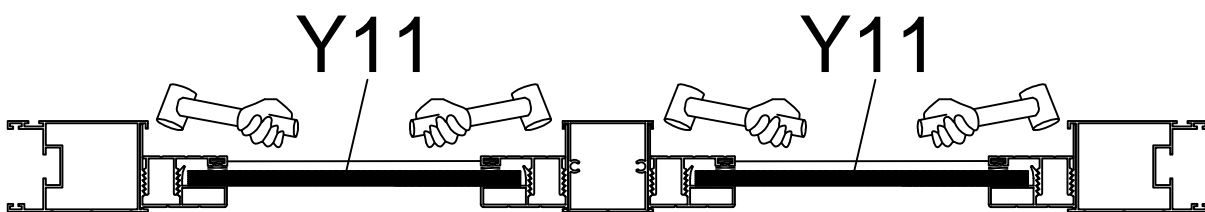
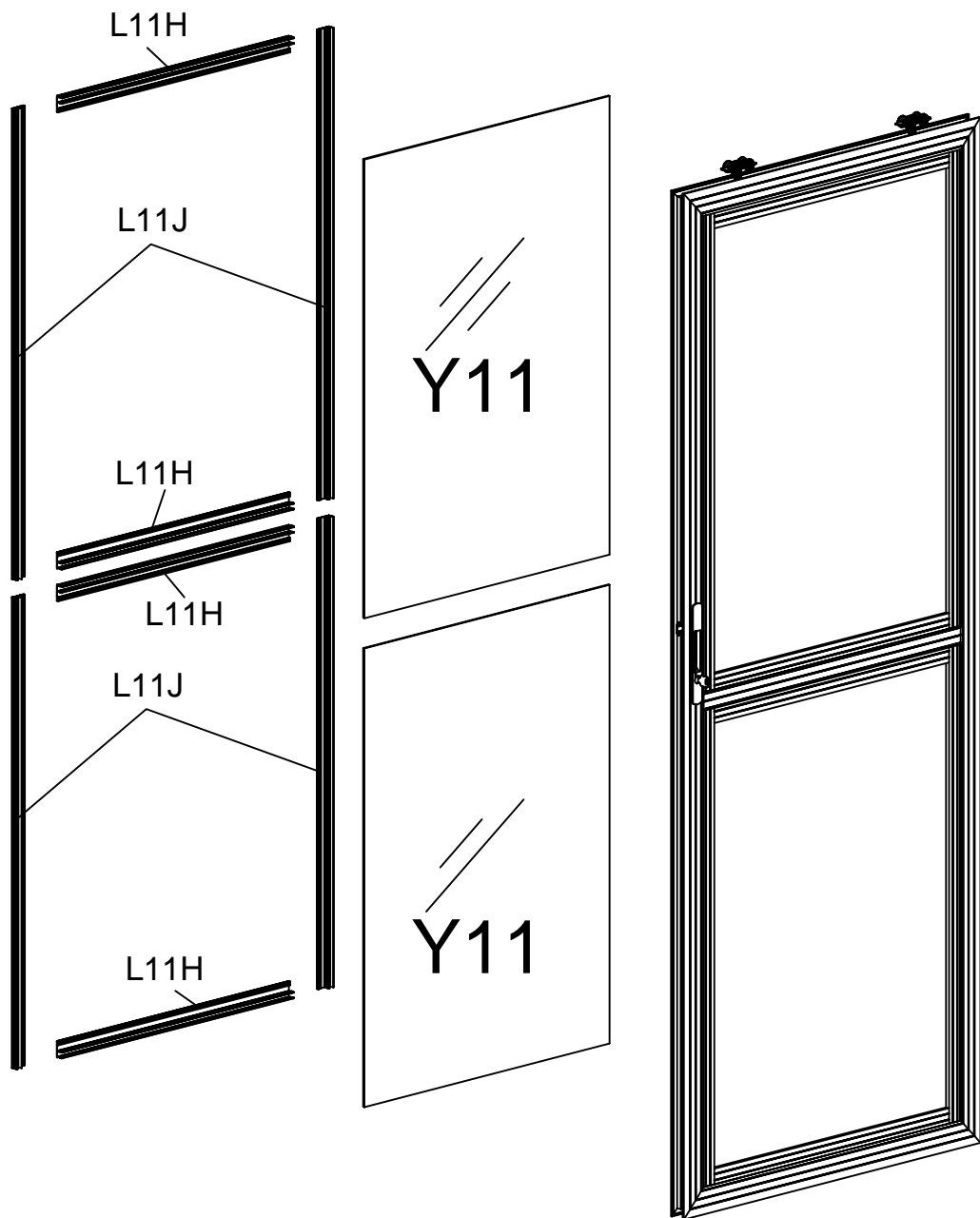

First the glazing panels should be loosely retained by the bar capping profiles L11H and L11J. Next tap the bar capping gently into position with a rubber mallet,

Slide 2xS02 into L18D, positioned 100mm away from each edge.  
Secure S02 using M02 bolts, then rotate the wheels  
to ensure free movement.

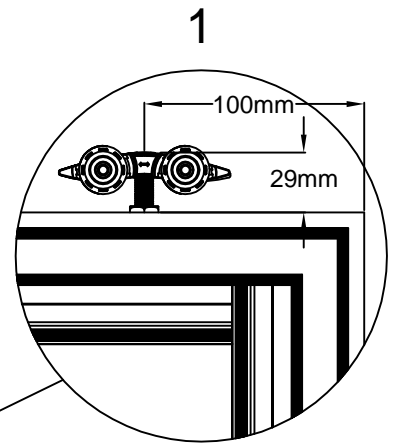
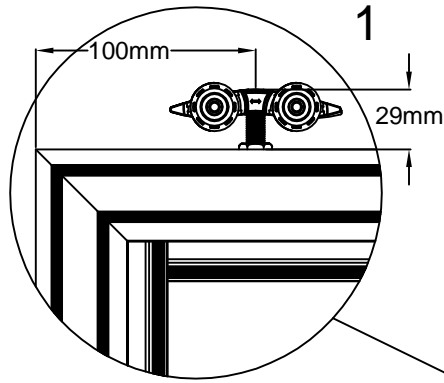
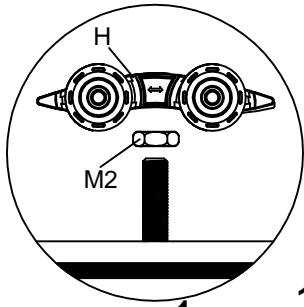

After Assembly

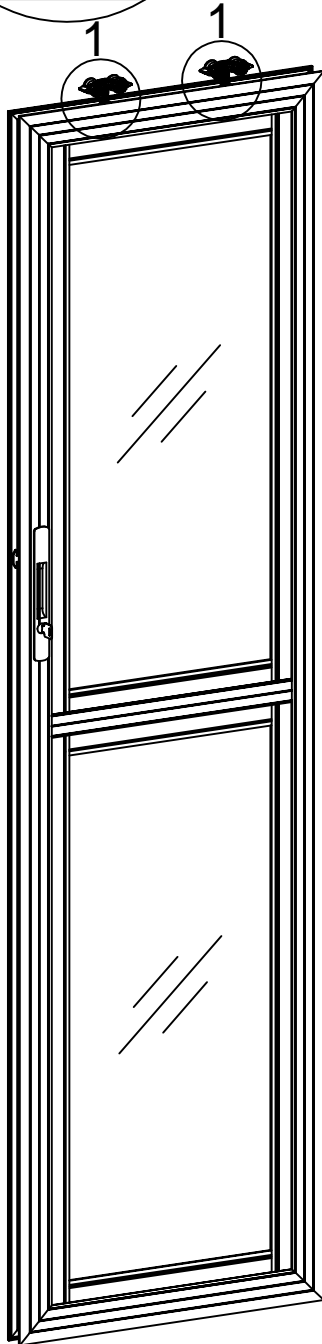

\* This is the method of adjusting the door height.

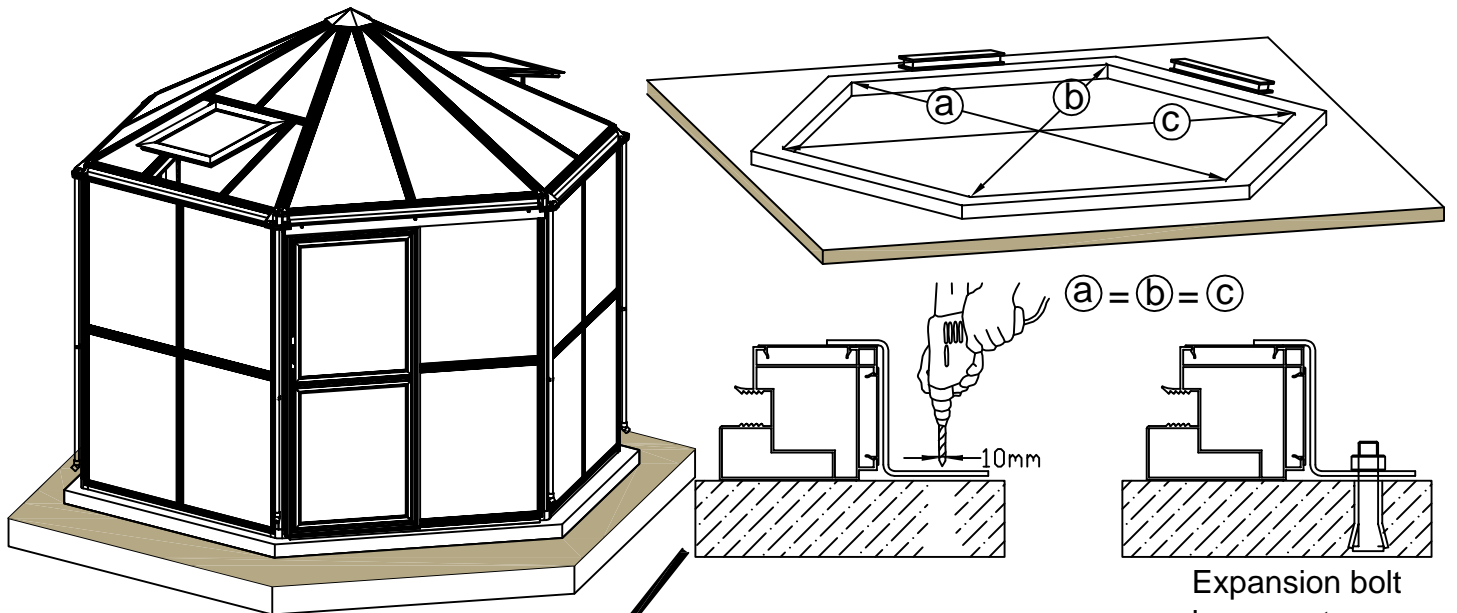

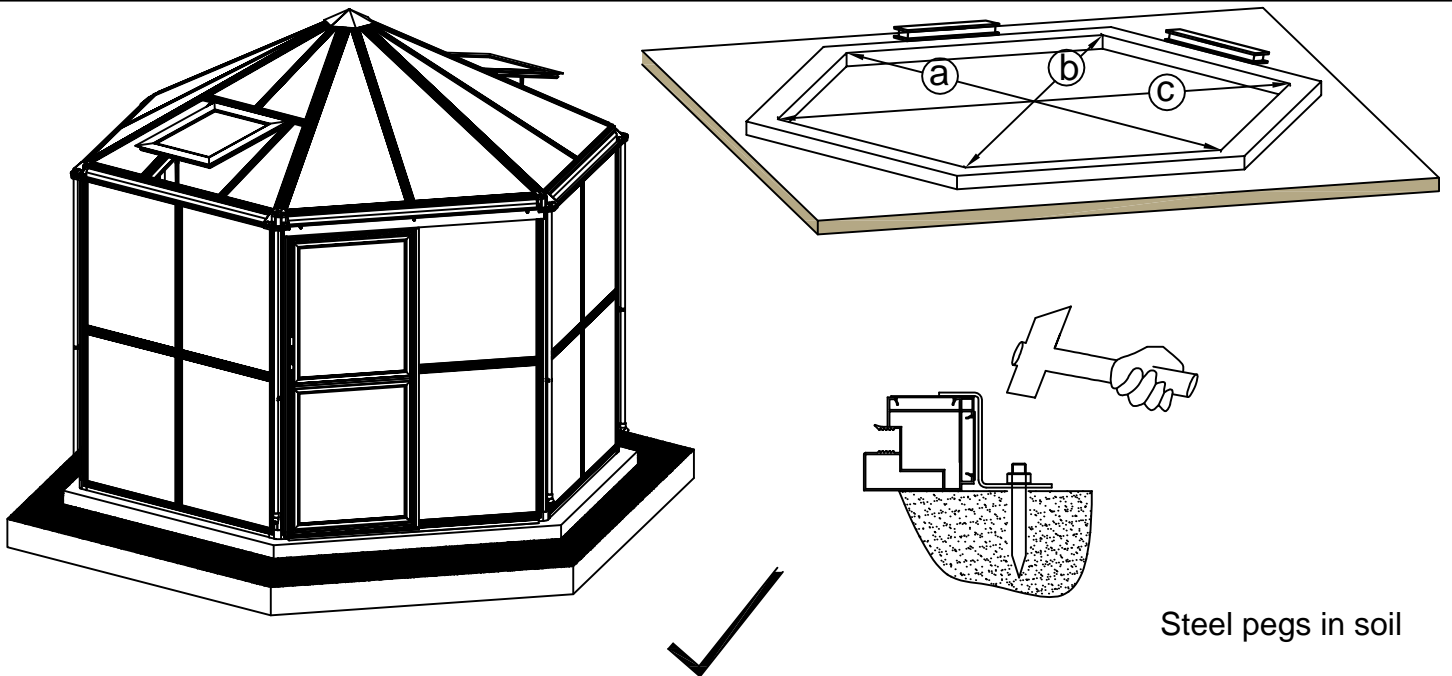

It is essential the dimensions  $a = b = c$  are the same to ensure the base is square.

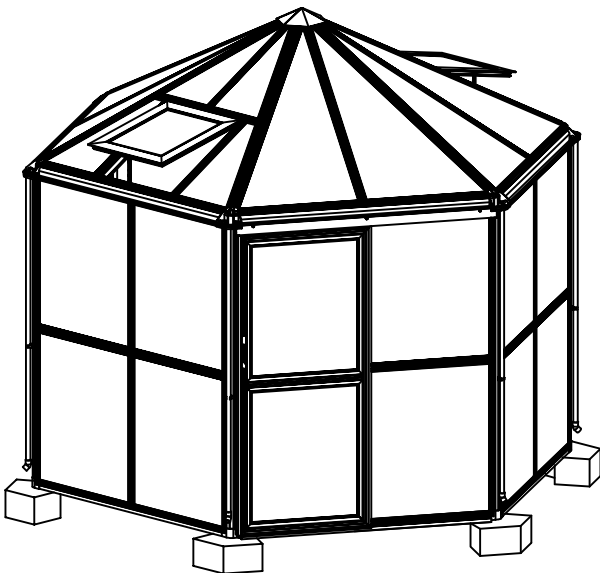

Support at the corners only is inadequate.





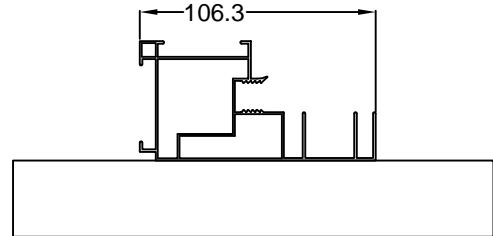
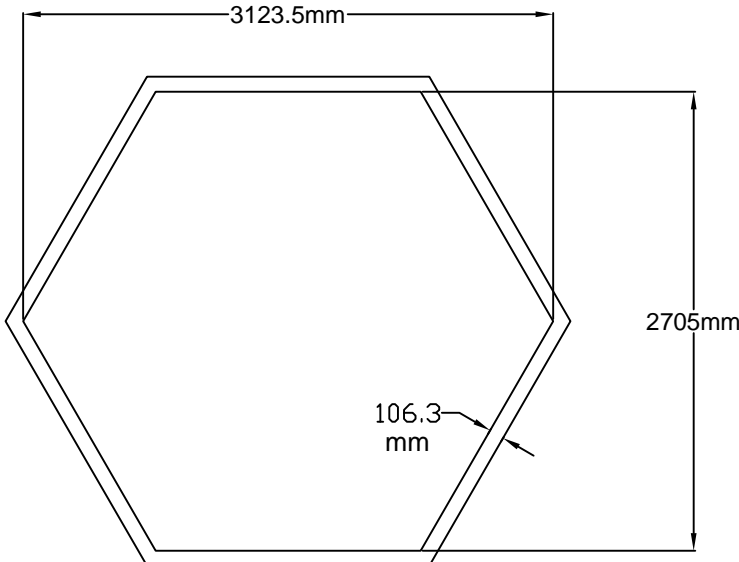

PART	NO	QTY
	W05	11
	S03 M8X60	11

# Expansion bolts assembly

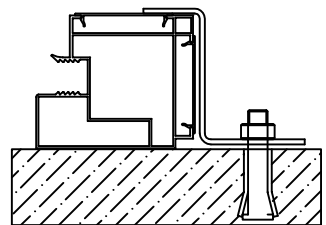
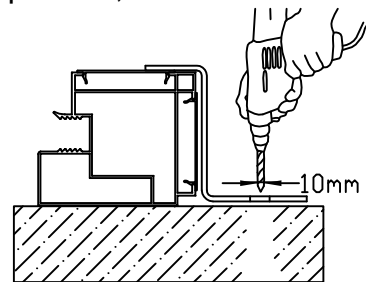
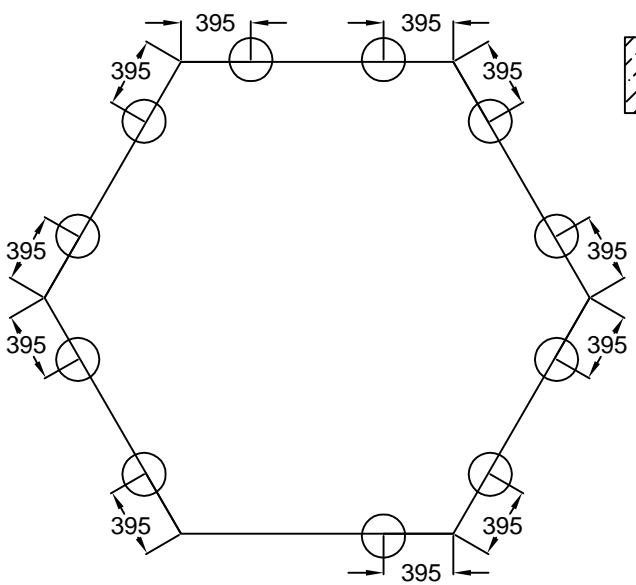

This size is the inner specification of the product,



PART	NO	QTY
	L08A	5
	L10	1
	A	6
	J01	6

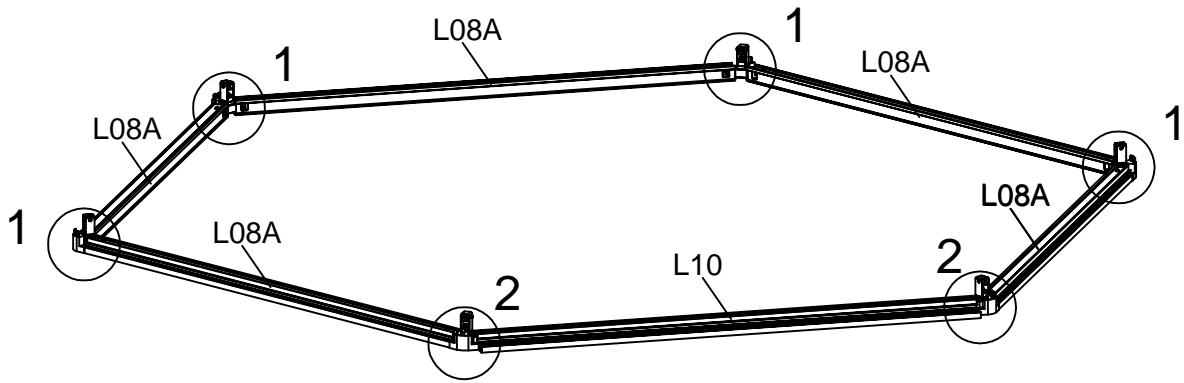

First lay out the aluminium profiles, connectors and anchor brackets approximately in place.

Make sure you pay close attention to the direction of the pins

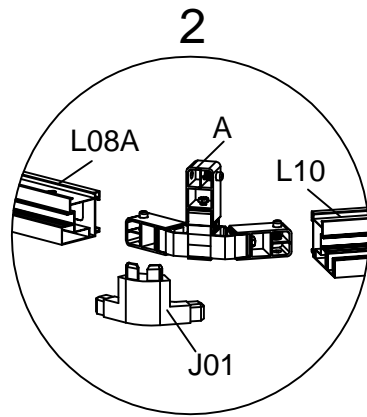
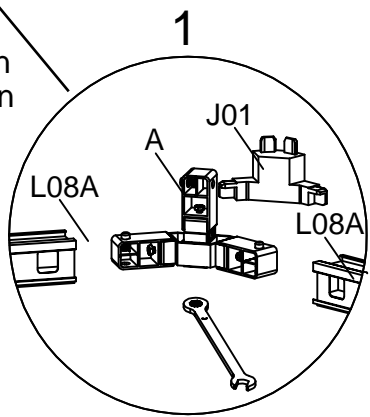

Assembly all the L08A and L10 with connector A. Insert connector A into L08A and L10, tight the bolts with the special spanner (provided) when the connector A is in the right position. Anchor bracket J01 must be assembled at the same time.



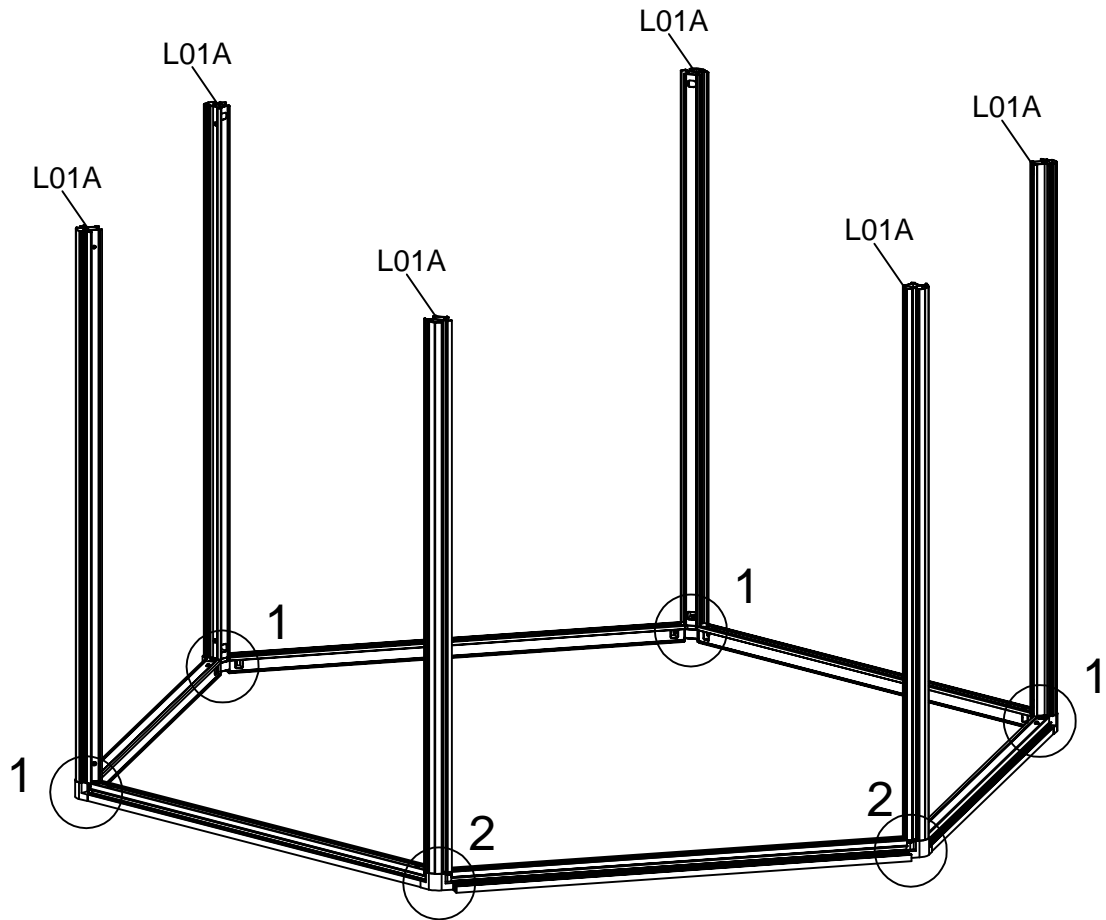

PART	NO	QTY
	L01A	6

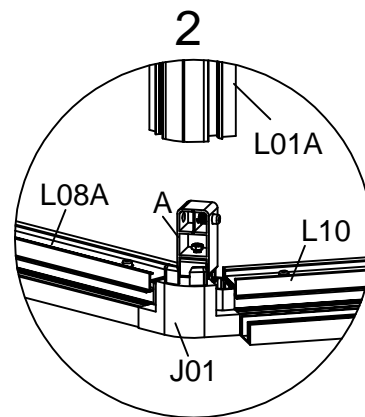
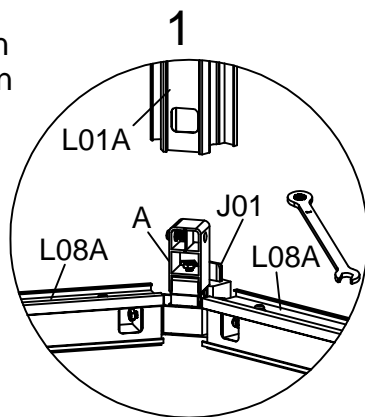

Make sure  
you pay  
close attention  
to the direction  
of the pins



Assembly L01A with connector A, insert connector A into L01A, tight the bolt with the special spanner when the it's in the right position.

PART	NO	QTY
	L07	6
	B	6
	J02	6
	S01	3
	M6X12	

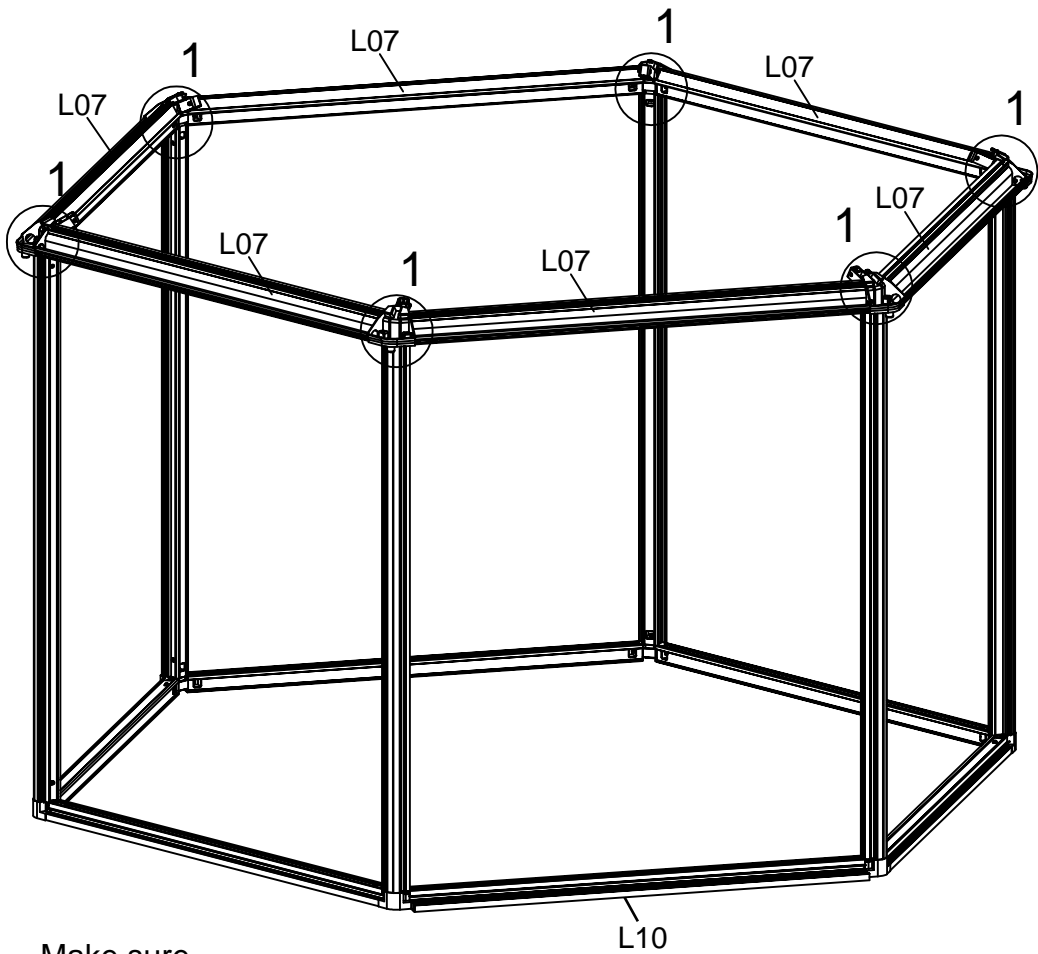

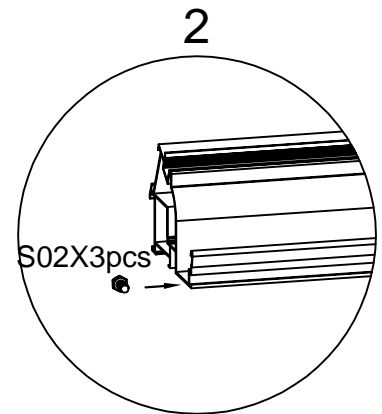
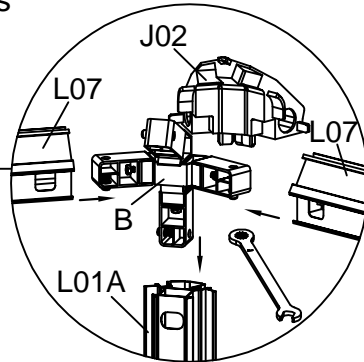
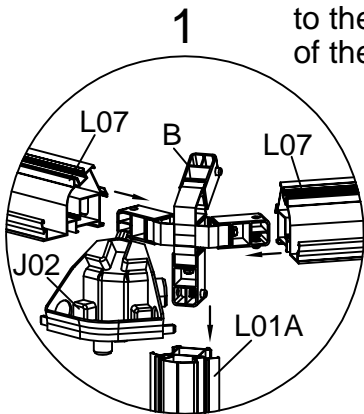

Make sure you pay close attention to the direction of the pins



Assembly L07 and L01A with connector B, insert connector B into L01A and L07, tight the bolt with the special spanner when the it's in the right position. Don't forget the anchor bracket J02.

Slide S01 (3PCS) into the channel of L07 for later use, the one which is Parallel to L10.



PART	NO	QTY
	L23A	6
	L23B	12

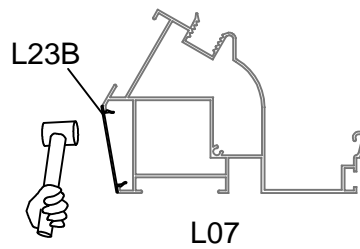
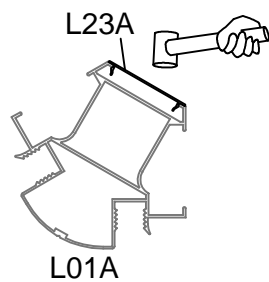
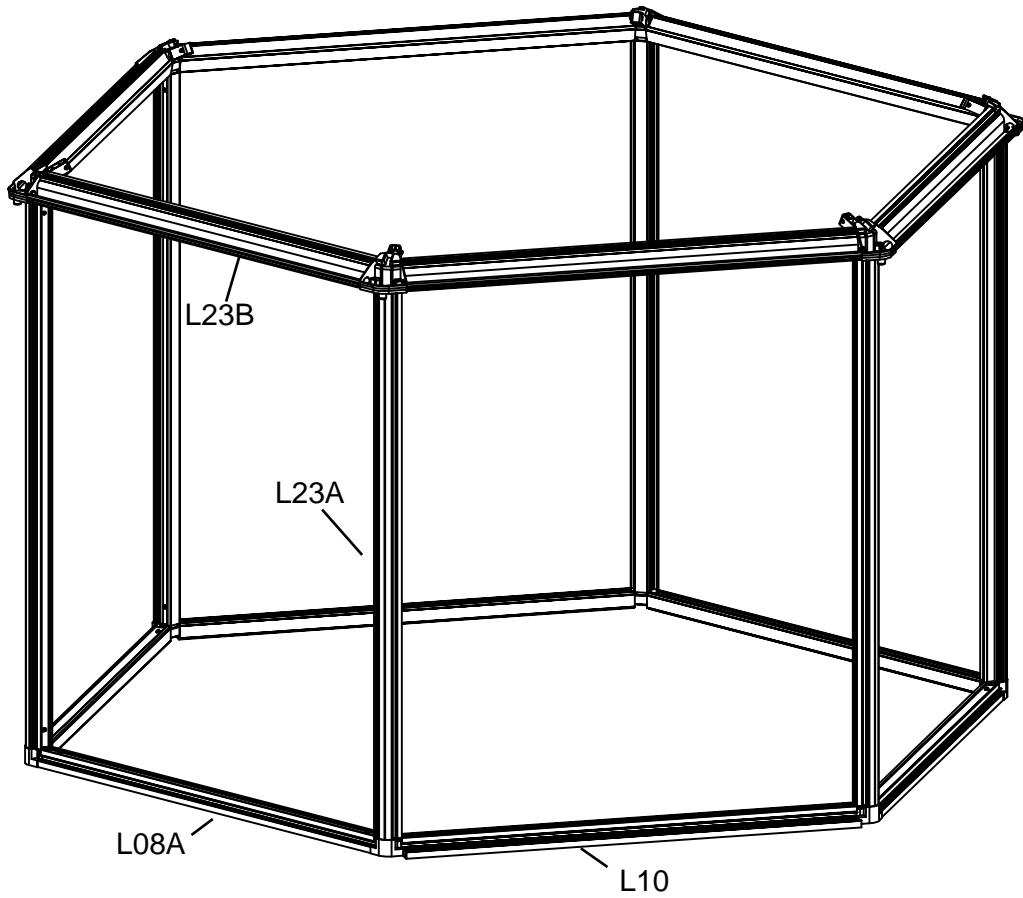

Please pay attention to the direction

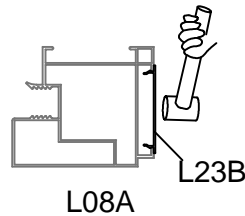
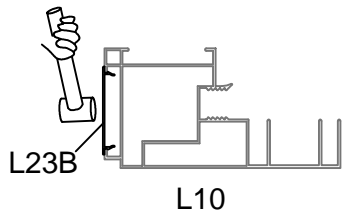

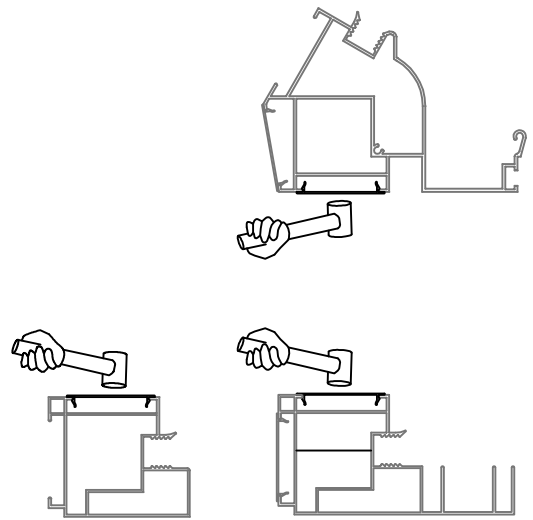
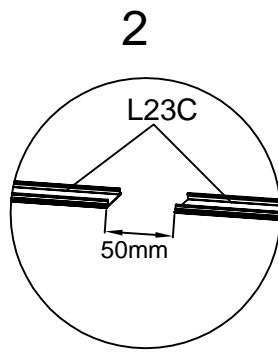
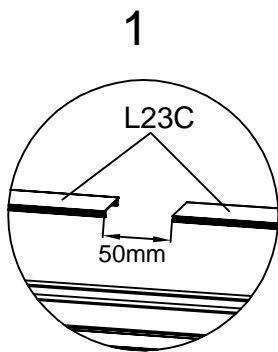
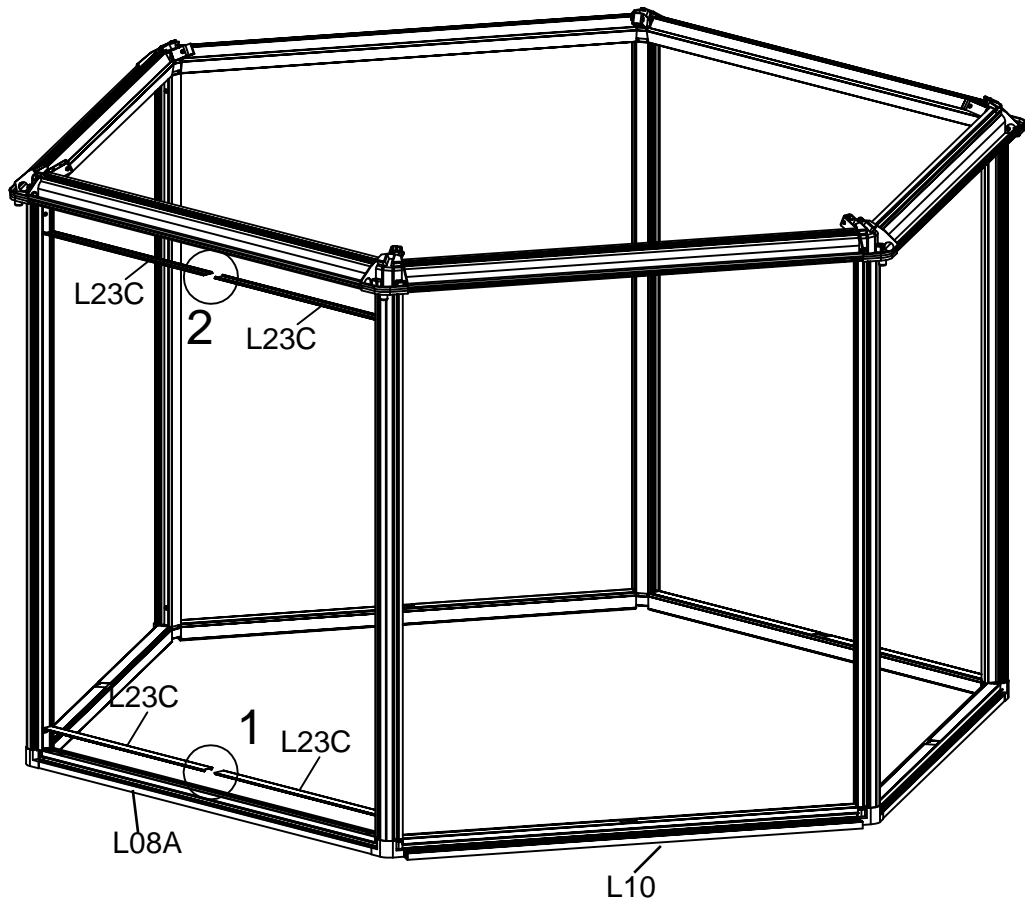

Tap the bar capping L23B into L10, L08A and L07, and L23A into L01A gently with a rubber mallet.

PART	NO	QTY
	L23C	24



Tap the bar capping L23C into L10 and L08A gently with a rubber mallet. Make sure you leave 50mm between the two L23C in the middle, for later assembly of L02A. Do the same on the other sides.

PART	NO	QTY
	L02A	6
	L23A	6
	K	12

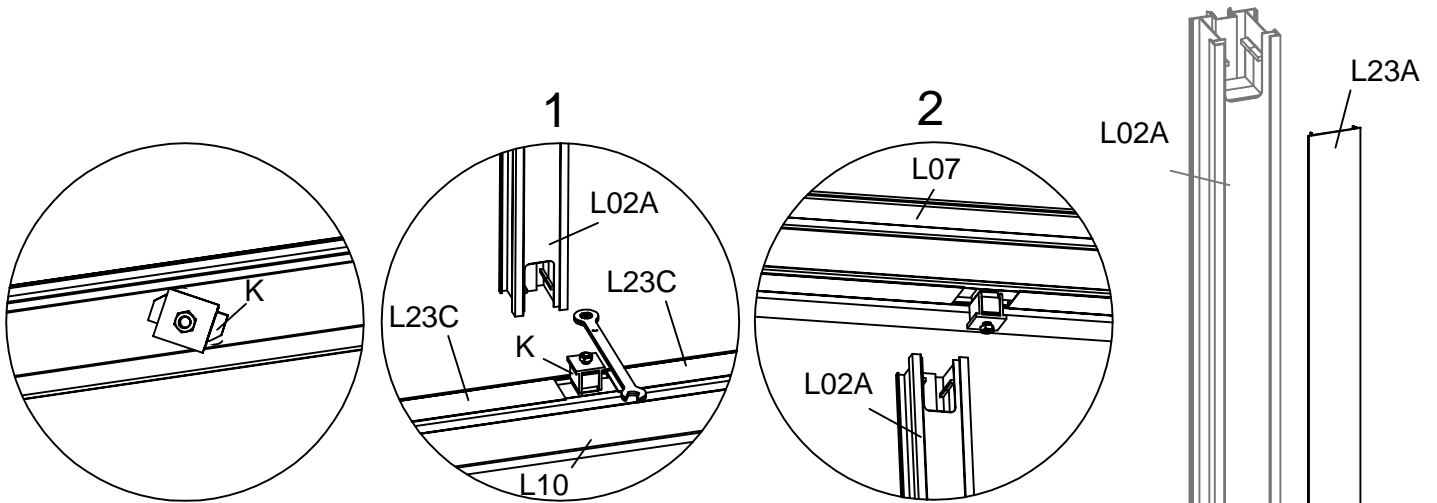
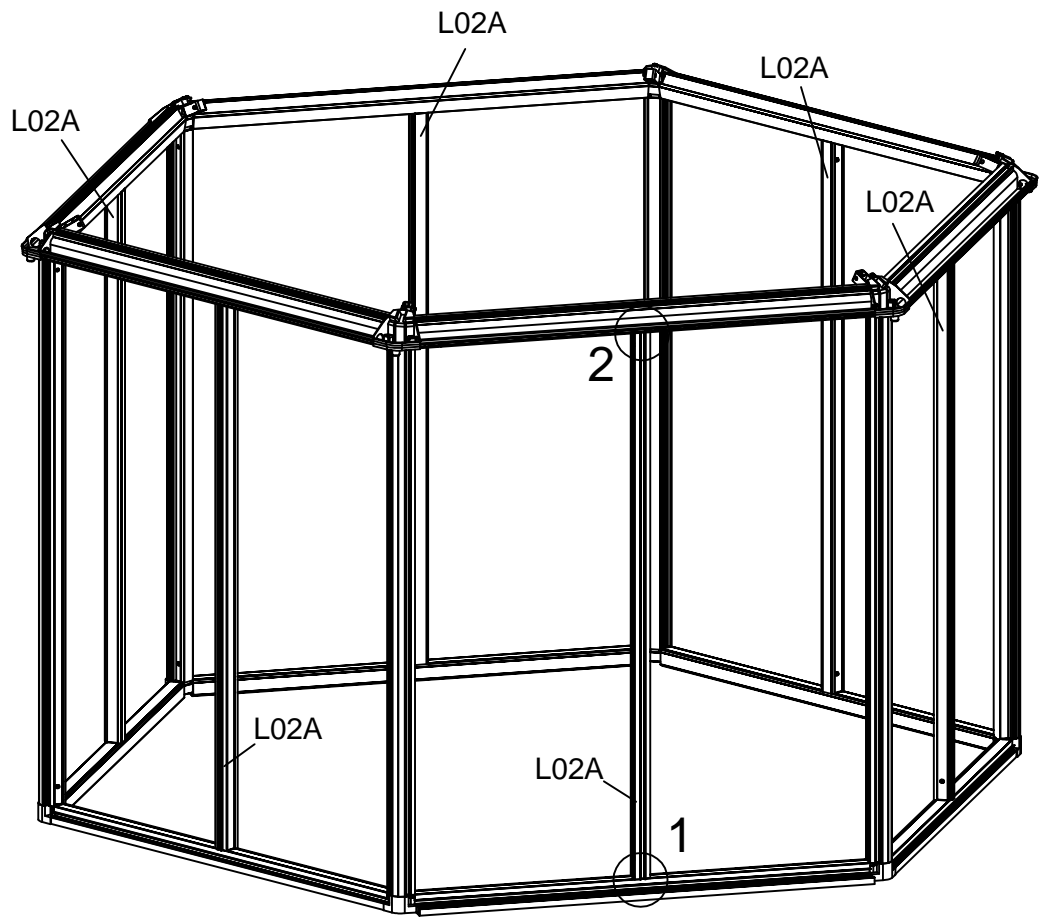

Slide in    Tight it up

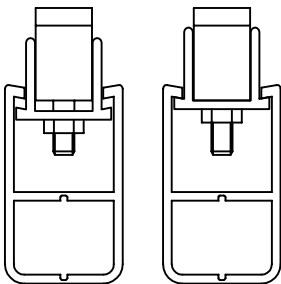

Put connector K into the slot of L07, L10 and L08A, turn its direction until it goes into the hole on L02A. Tight the bolt in the connector K with the spanner. Pay attention to the direction on the spanner.

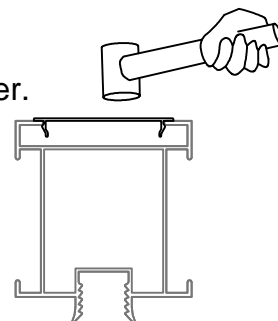

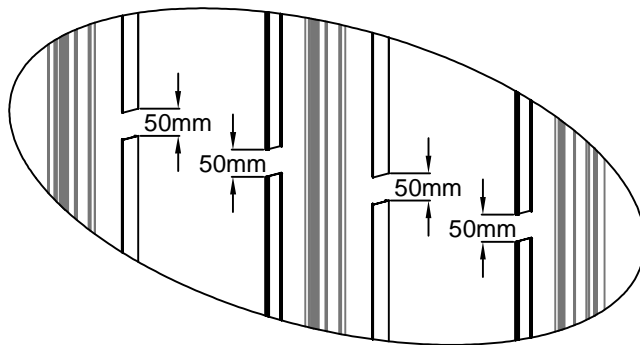
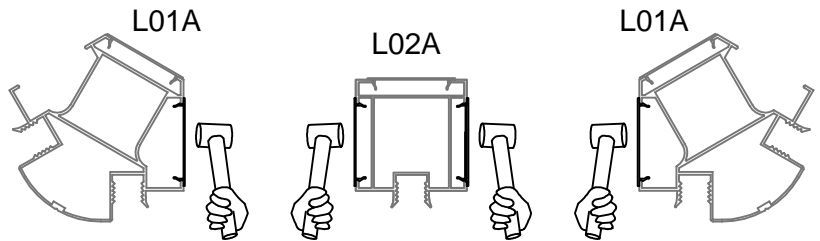
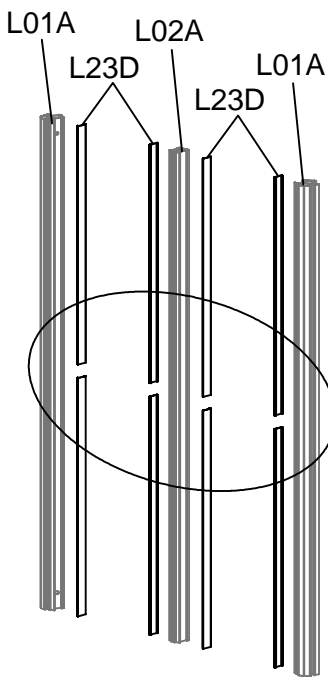
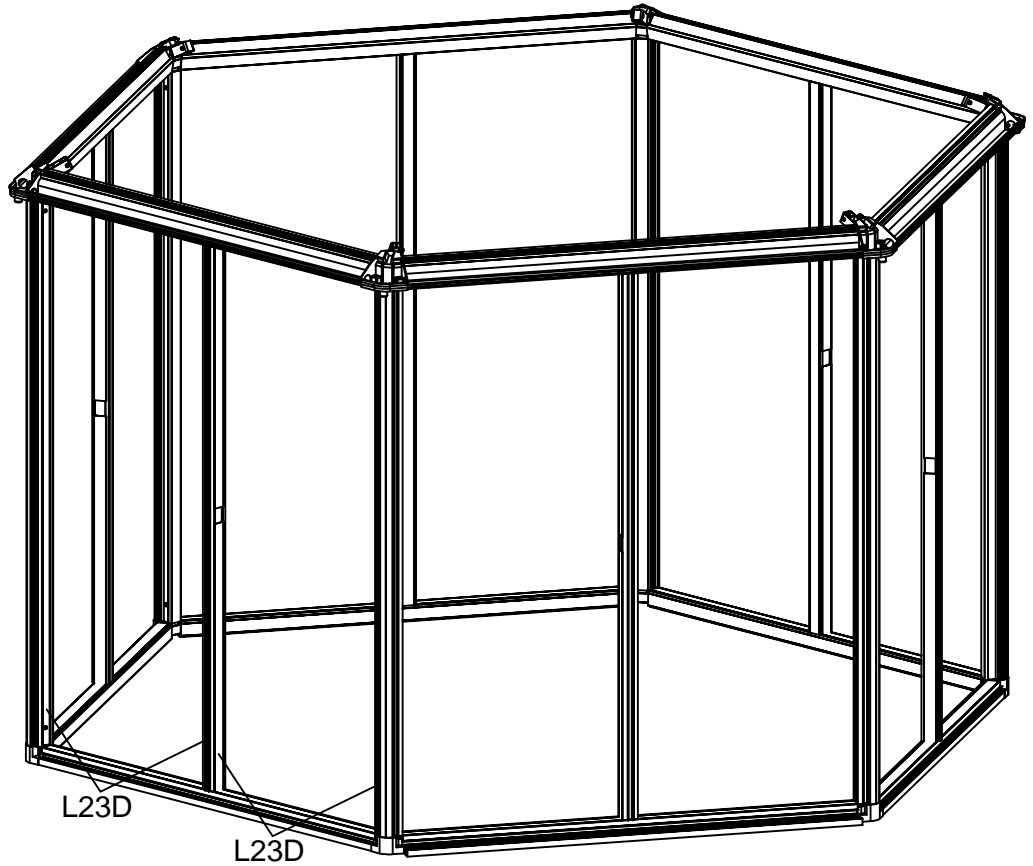

Tap the bar capping L23A into L02A gently with a rubber mallet.

PART	NO	QTY
	L23D	40



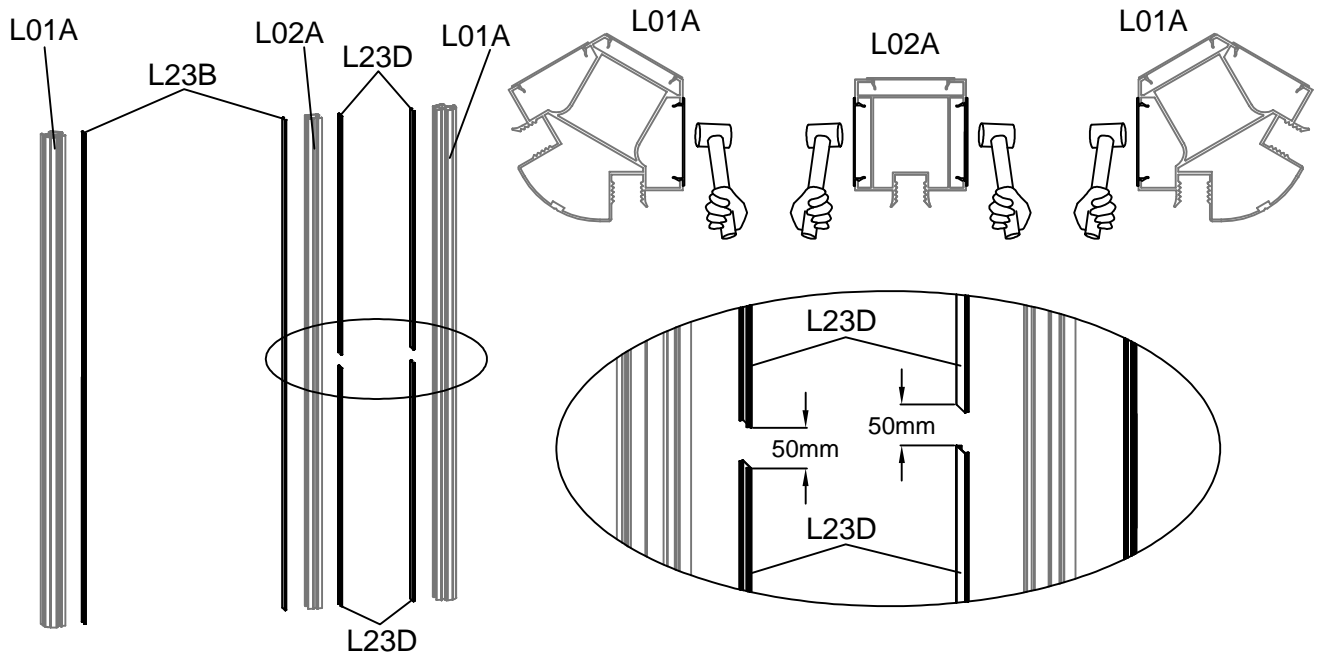
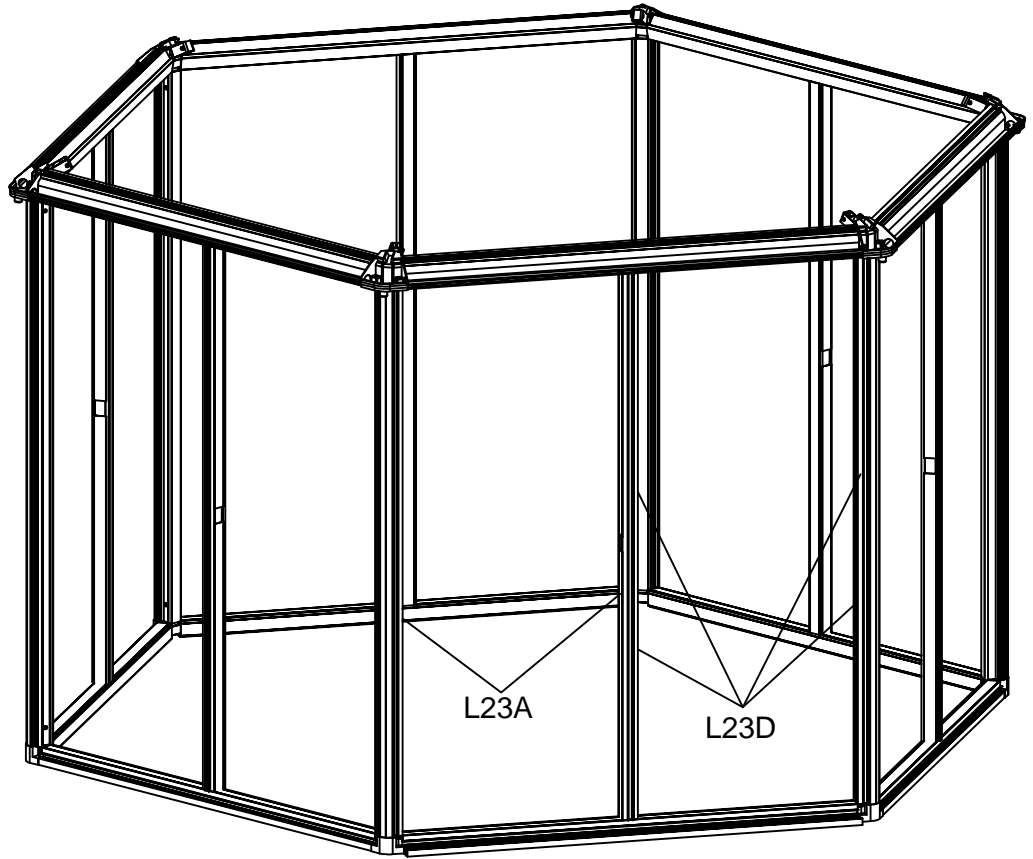

Tap the bar capping L23D into L01A and L02A gently with a rubber mallet.  
 Make sure you leave 50mm between the two L23D in the middle, for later assembly of L02K.  
 Do the same on the other sides.

PART	NO	QTY
	L23A	2
	L23D	4



Tap the bar capping L23A and L23D into L01A and L02A gently with a rubber mallet. Make sure you leave 50mm between the two L23D in the middle, for later assembly of L02K. Do the same on the other sides.

PART	NO	QTY
	L02K	11
	K	22

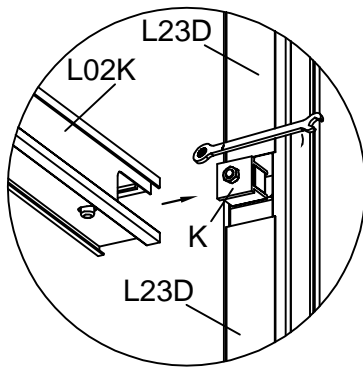
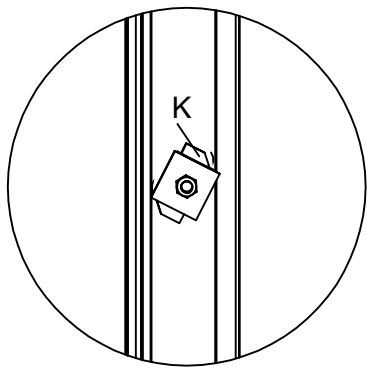
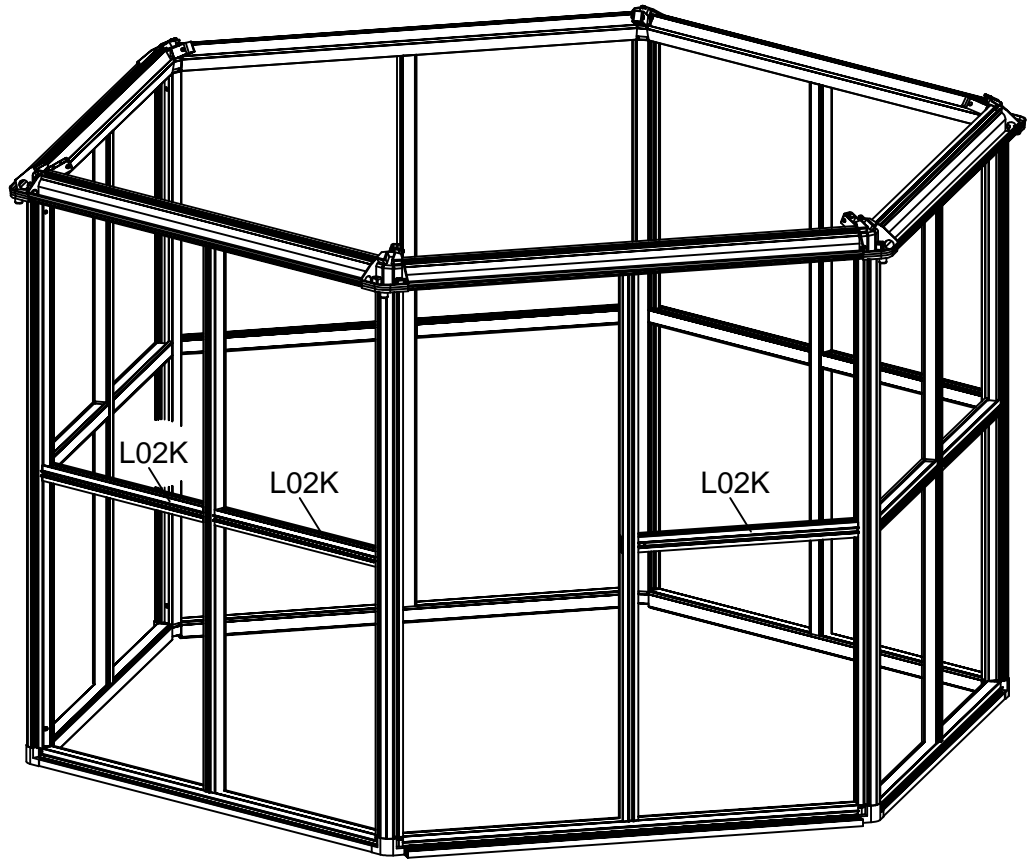

Slide in

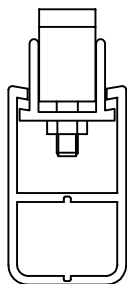

Tight it up

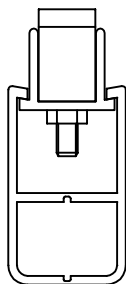



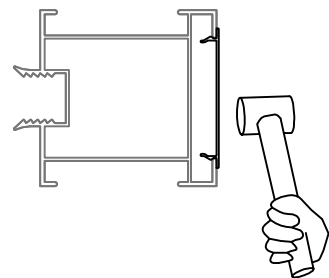
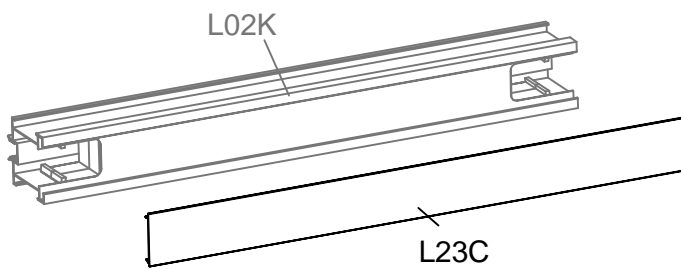
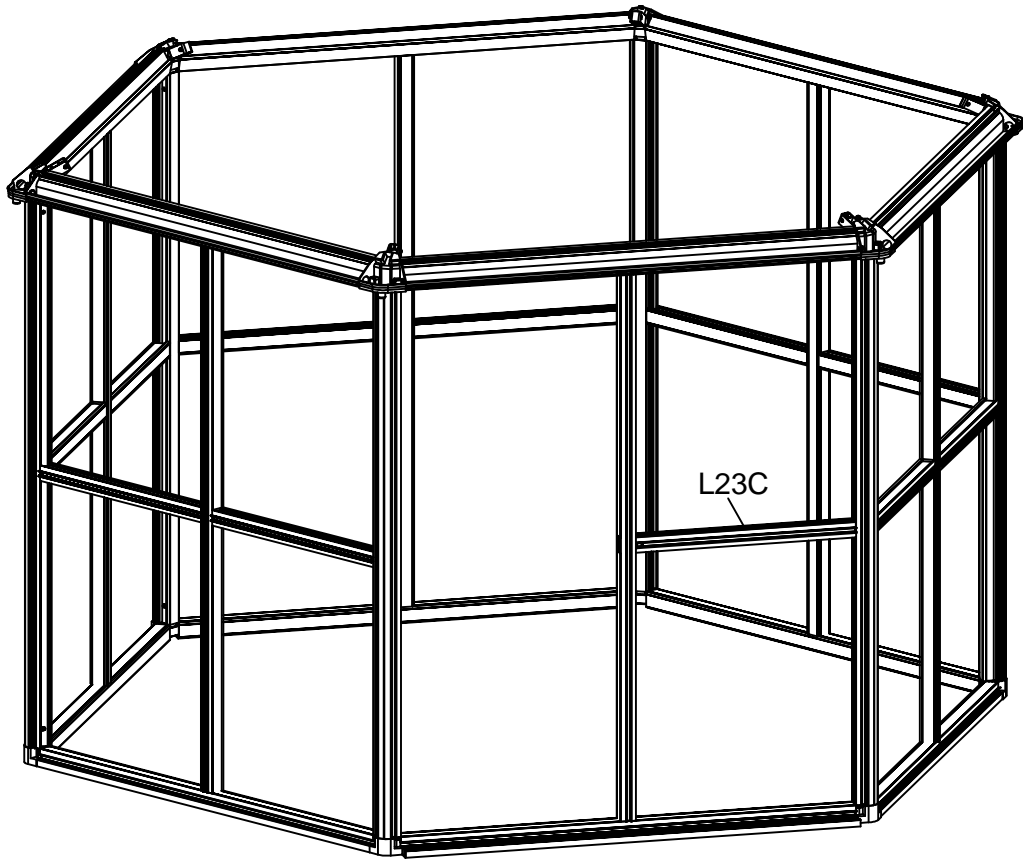

Put connector K into the slot of L02A and L01A, turn its direction until it goes into the hole on L02K. Tight the bolt in the connector K with the spanner. Pay attention to the direction on the spanner.

PART	NO	QTY
	L23C	11





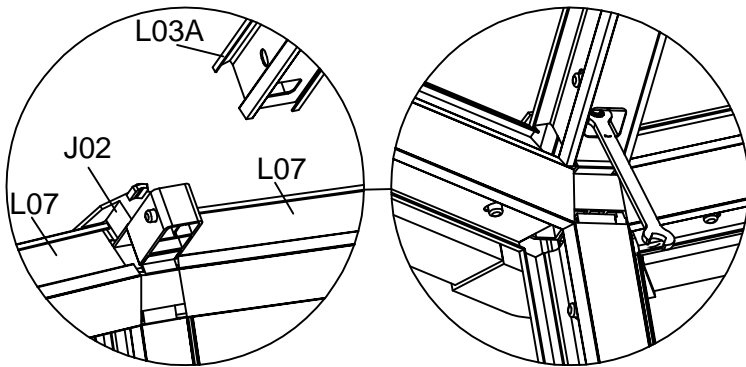
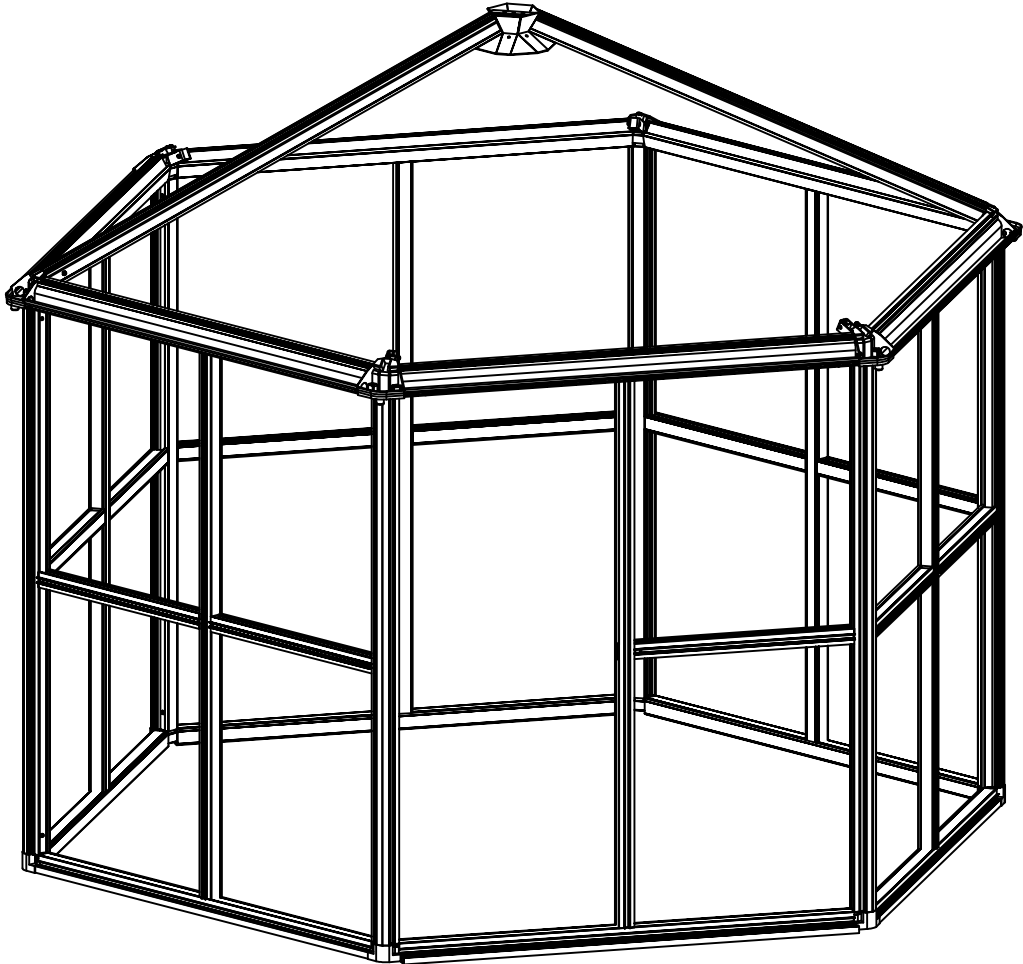
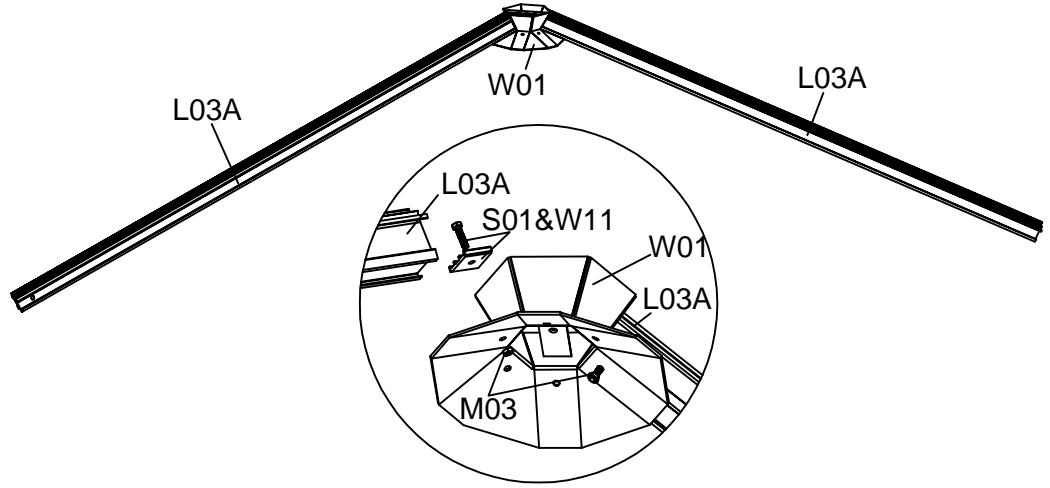

Tap the bar capping L23C into L02K gently with a rubber mallet.

PART	NO	QTY
	L03A	2
	W11	2
	S01	2
	M6X12	
	M03	2
	M6	
	W01	1





Assembly L03A with connector B, insert connector B into L03A, tight the bolt with the special spanner when the it's in the right position. Don't forget to assembly the anchor bracket J02 at the same time.

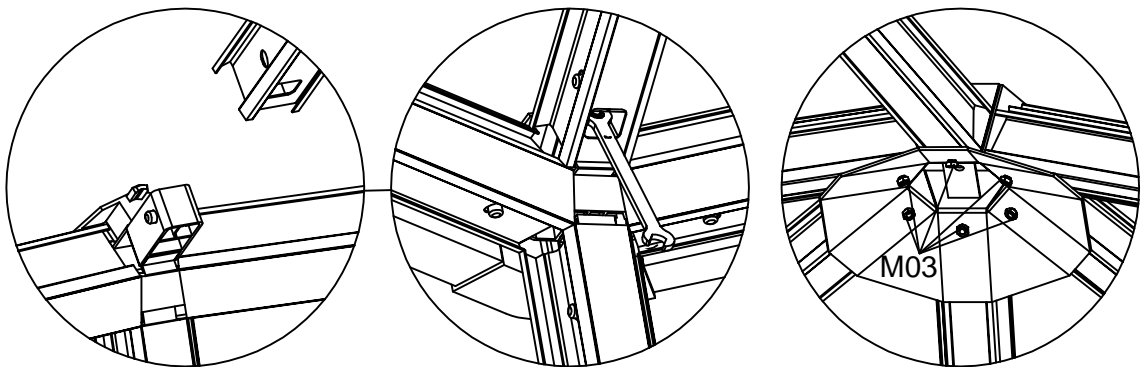
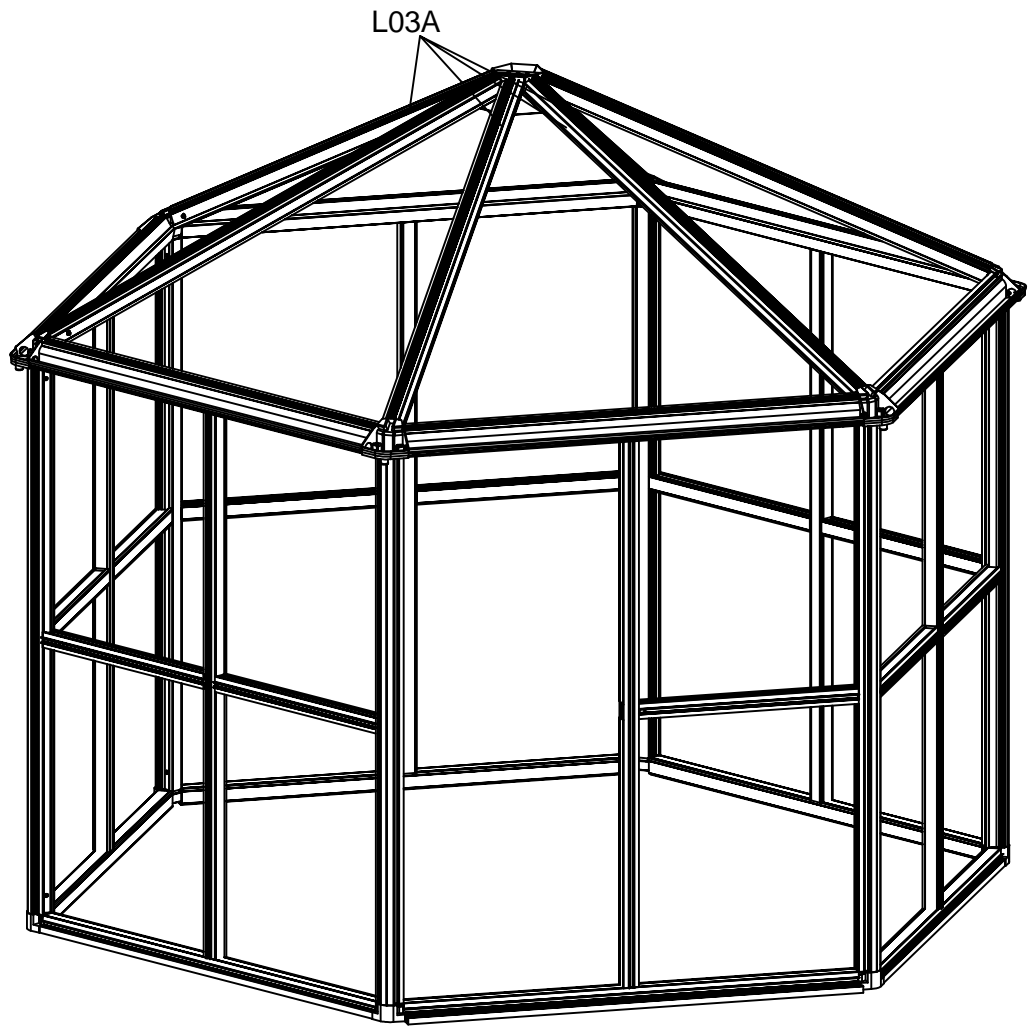

PART	NO	QTY
	L03A	4
	W11	4
	S01	4
	M6X12	
	M03	4
	M6	



Do the same for the left L03A.

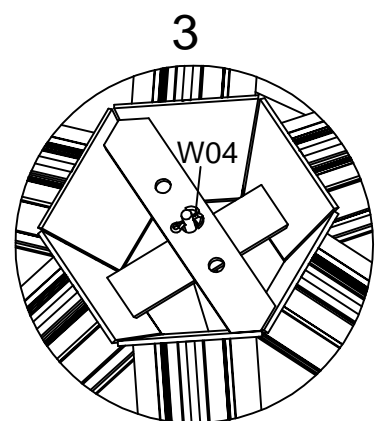
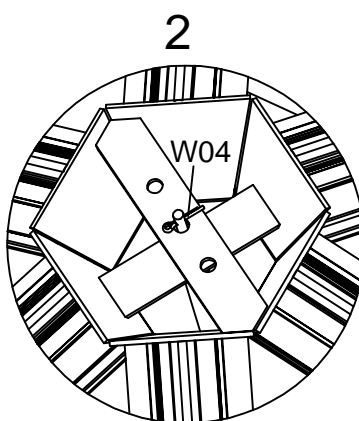
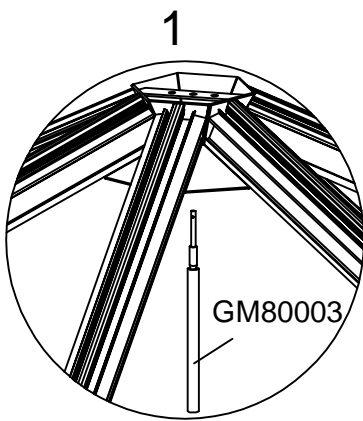
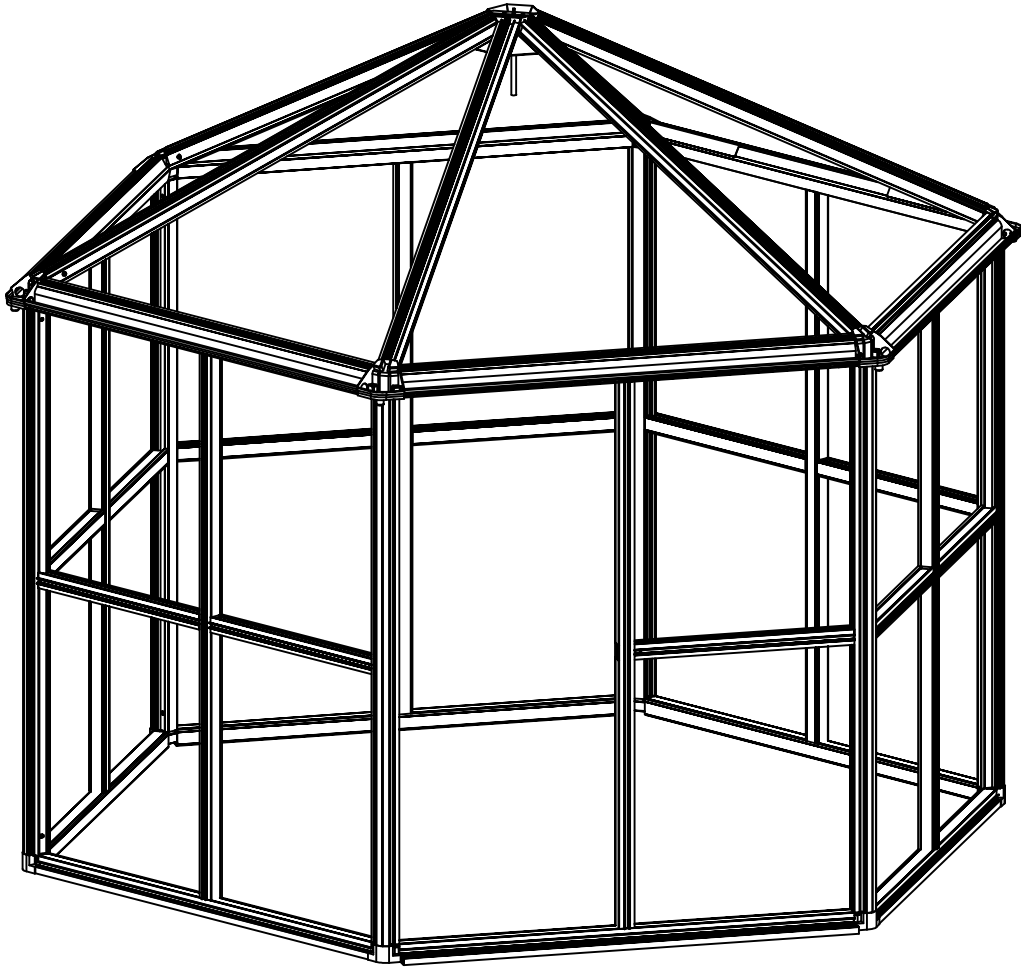

PART	NO	QTY
	GM80003	1
	W04	1

## Auto Cap Assembly



Put automatic opener GM80003 through the central hole on W01 (fig. 1).

Use plug W04 to pass over the hole on GM80003 (fig. 2), bend and secure it (fig 3).





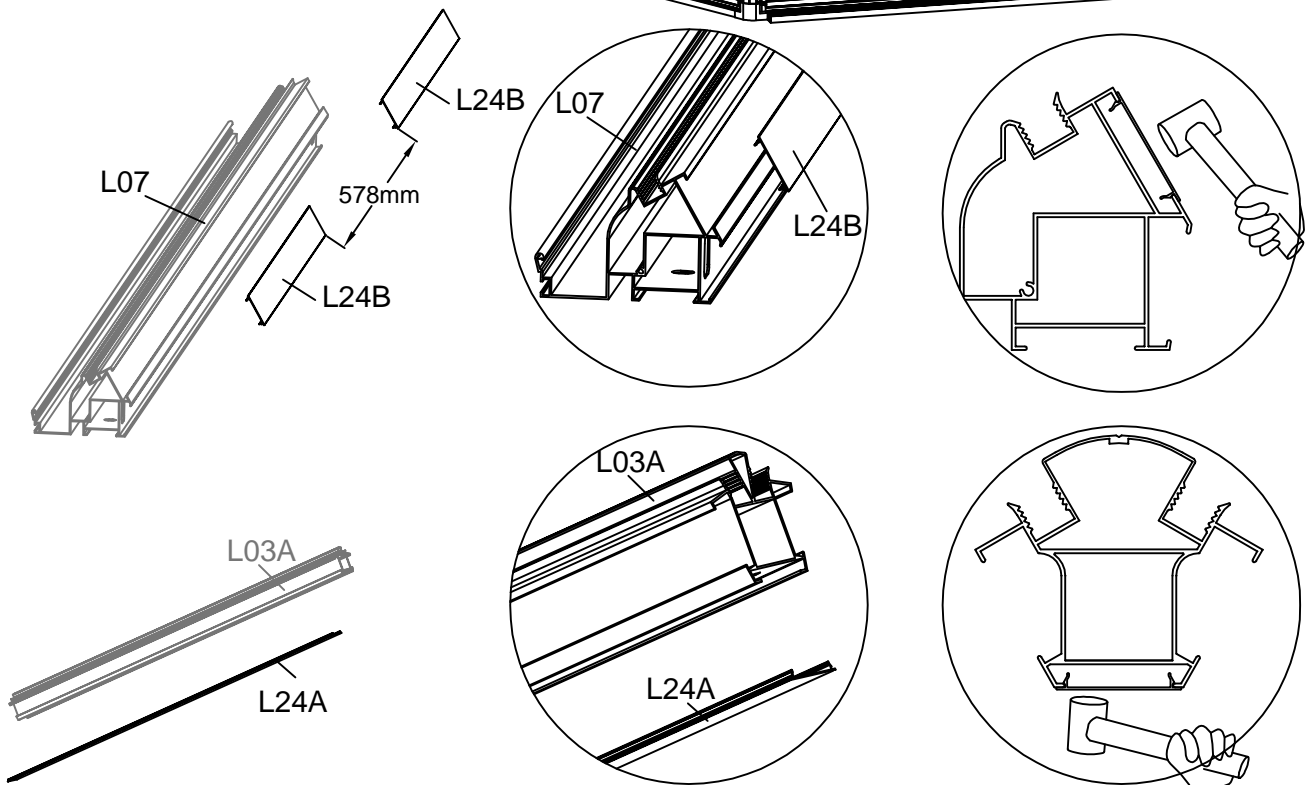
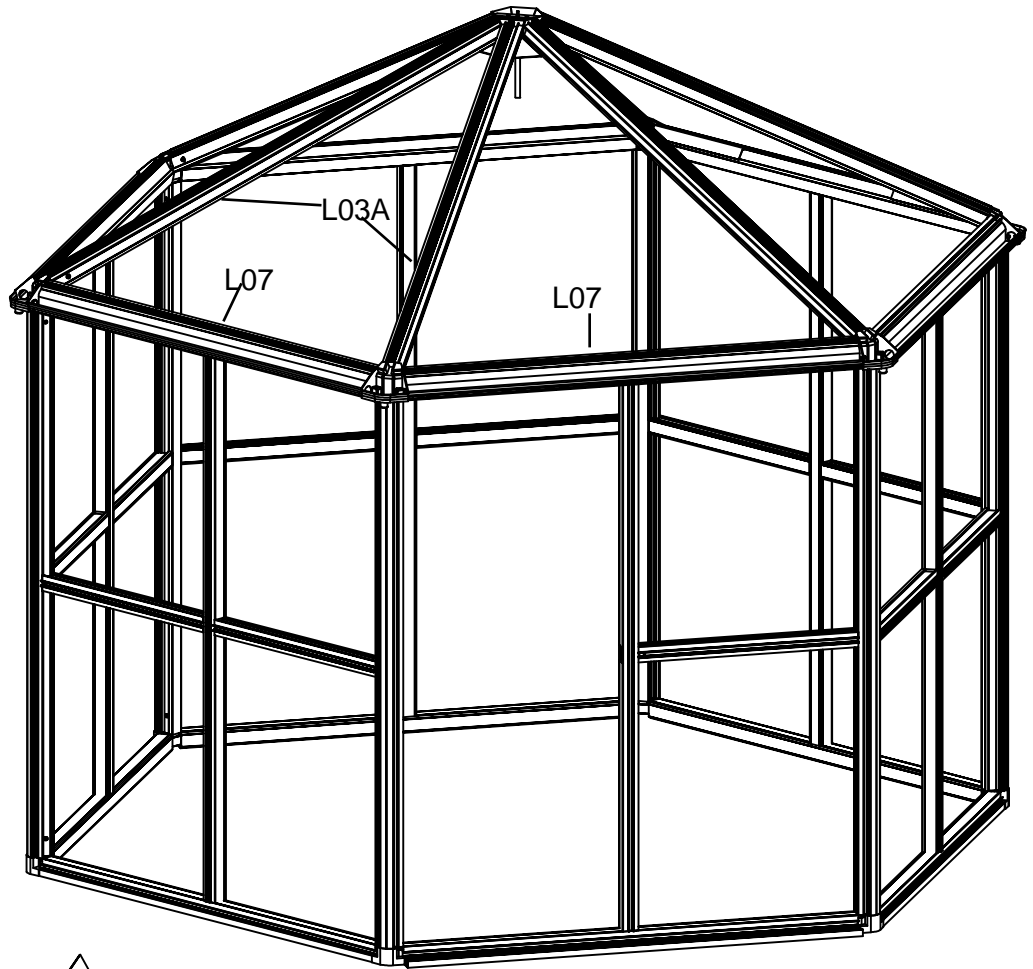



PART	NO	QTY
	L24A	6
	L24B	4

Roof frame on the window vent side assembly



Tap the bar capping L24A into L03A and L24B into L07 gently with a rubber mallet. Make sure you leave 50mm between the two L24B in the middle, for later assembly of L02D. Do the same on the other side which you want to assemble the window vent (2 standard window vents for one set).

Please note this is the methods of assembly the roof frame with window vents only.

PART	NO	QTY
	L02C	2
	L02D	4
	L02E	2
	L25A	4
	L25B	4
	K	6
	W11	2
	S01	2
	M6X12	

Roof frame on the window vent side assembly

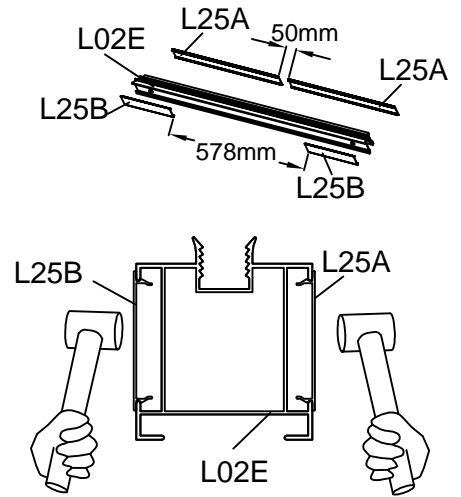
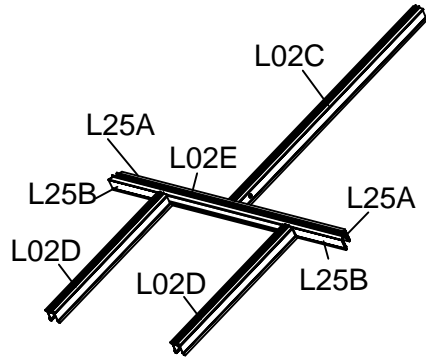

Tap the bar capping L25A and L25B into L02E gently with a rubber mallet.

Make sure you leave 50mm between the two L25A in the middle, for later assembly of L02C, and leave 578mm between the two L25B in the middle, for later assembly of L02D.

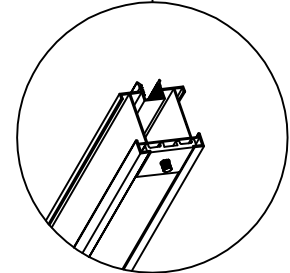
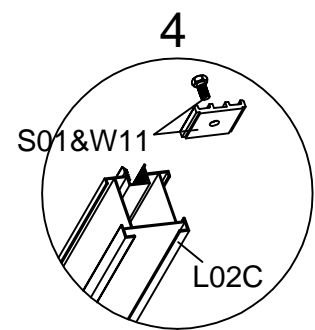
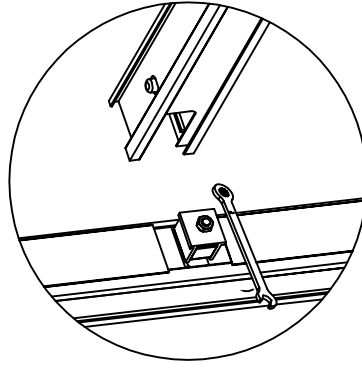
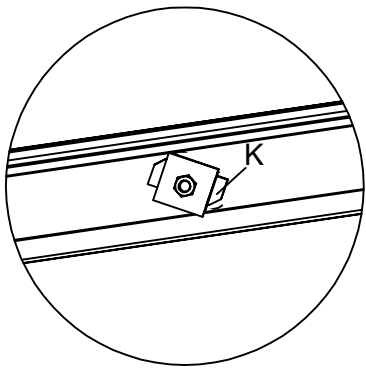
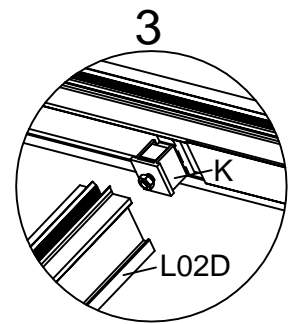
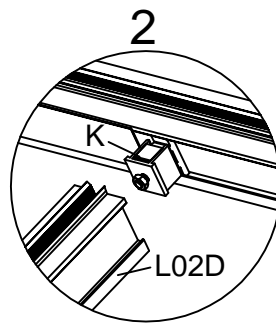
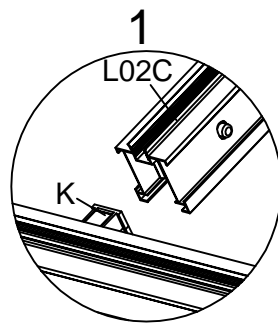
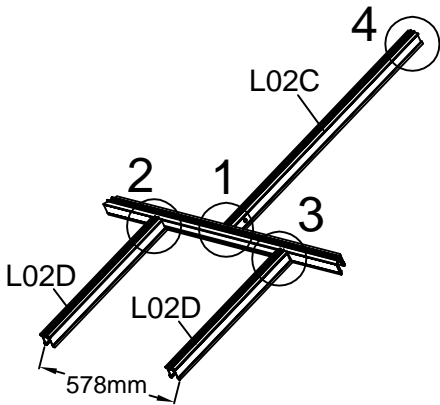

Slide in

Tight it up

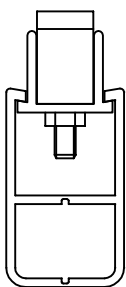
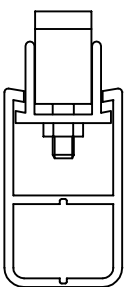

Put connector K into the slot of L02E turn its direction until it goes into the hole on L02C/L02D. Tight the bolt in the connector K with the spanner. Pay attention to the direction on the spanner. After assembly, L02C is in the middle of L02E, and the outer distance of the two L02D is 578mm.

PART	NO	QTY
	K	4
	N	4
	M03 M6	2

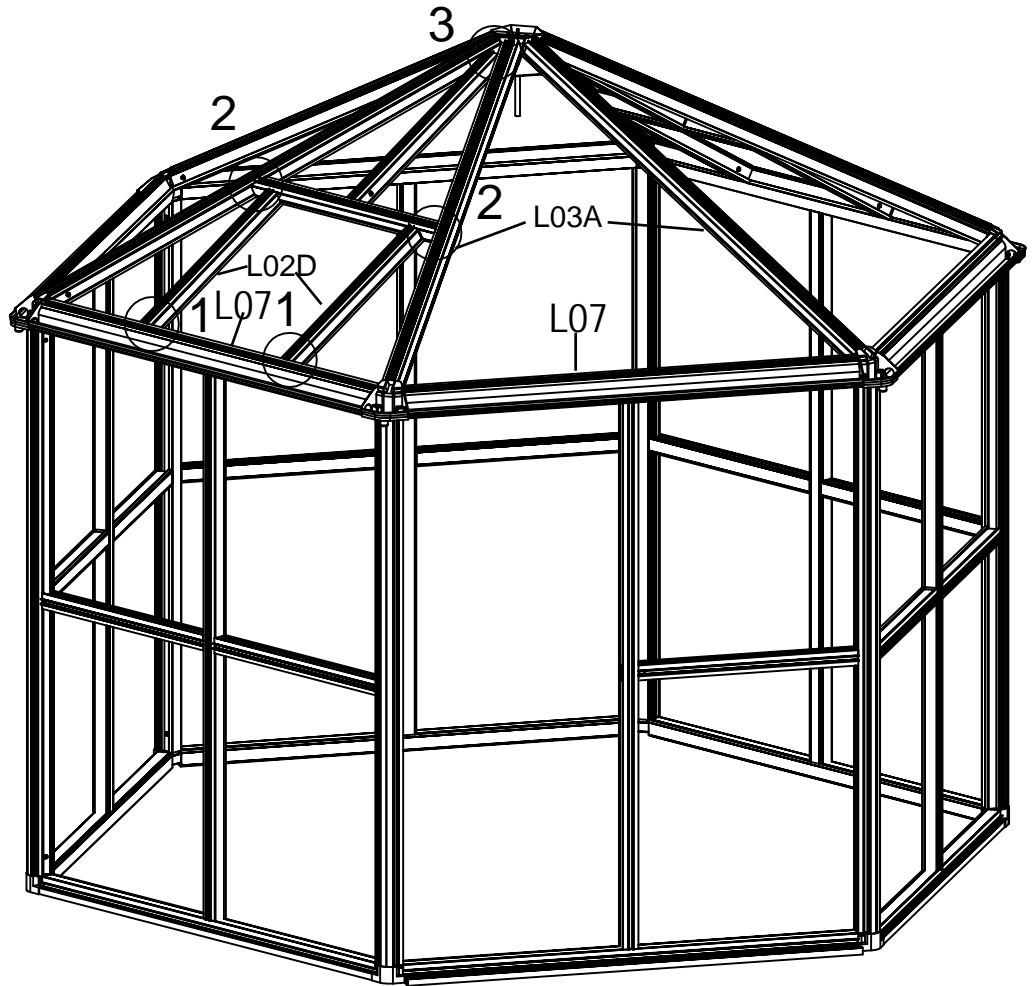

1

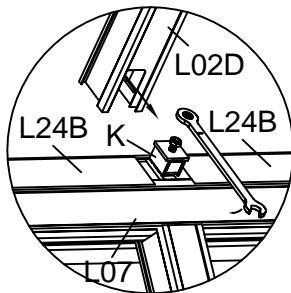
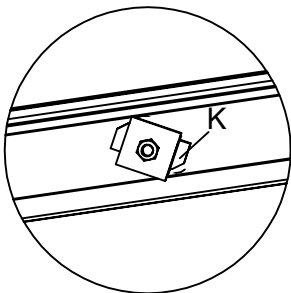

Put connector K into the slot of L07 turn its direction until it goes into the hole on L02D. Tight the bolt in the connector K with the spanner. Pay attention to the direction on the spanner.

2

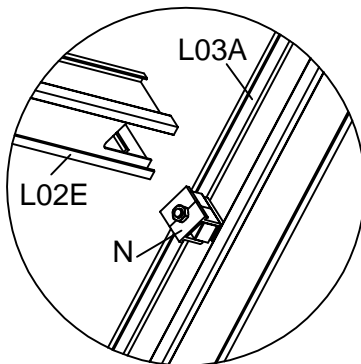
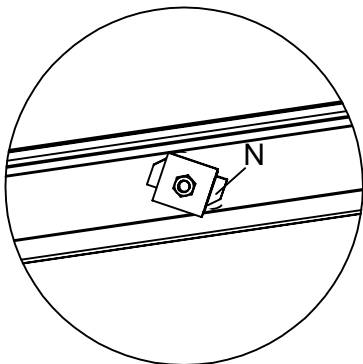

Slide in

Tight it up

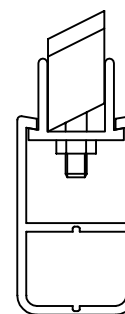
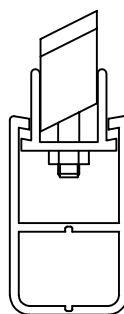

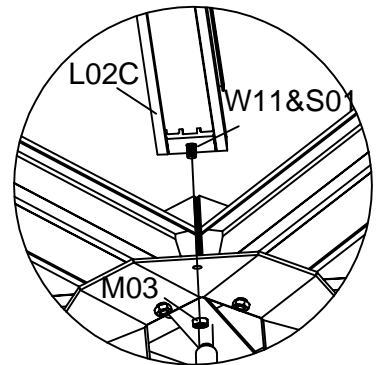

3



Put connector N into the slot of L03A turn its direction until it goes into the hole on L02E. Tight the bolt in the connector N with the spanner.

Pay attention to the direction on the spanner.

Please do the same on the side which you want to assemble the window vent.

PART	NO	QTY
	L25C	2
	L25D	4
	L25E	2

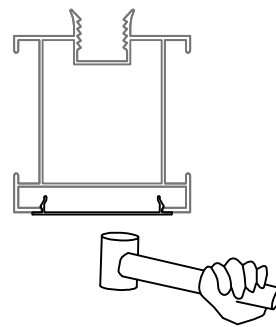
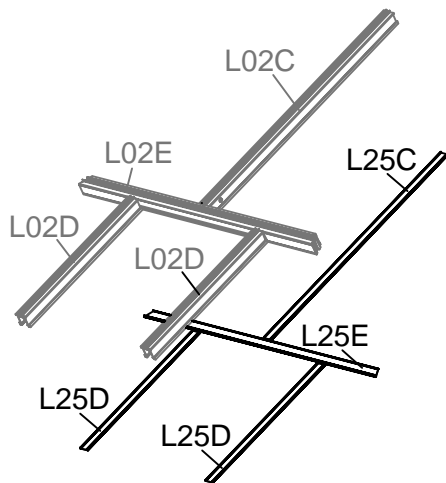
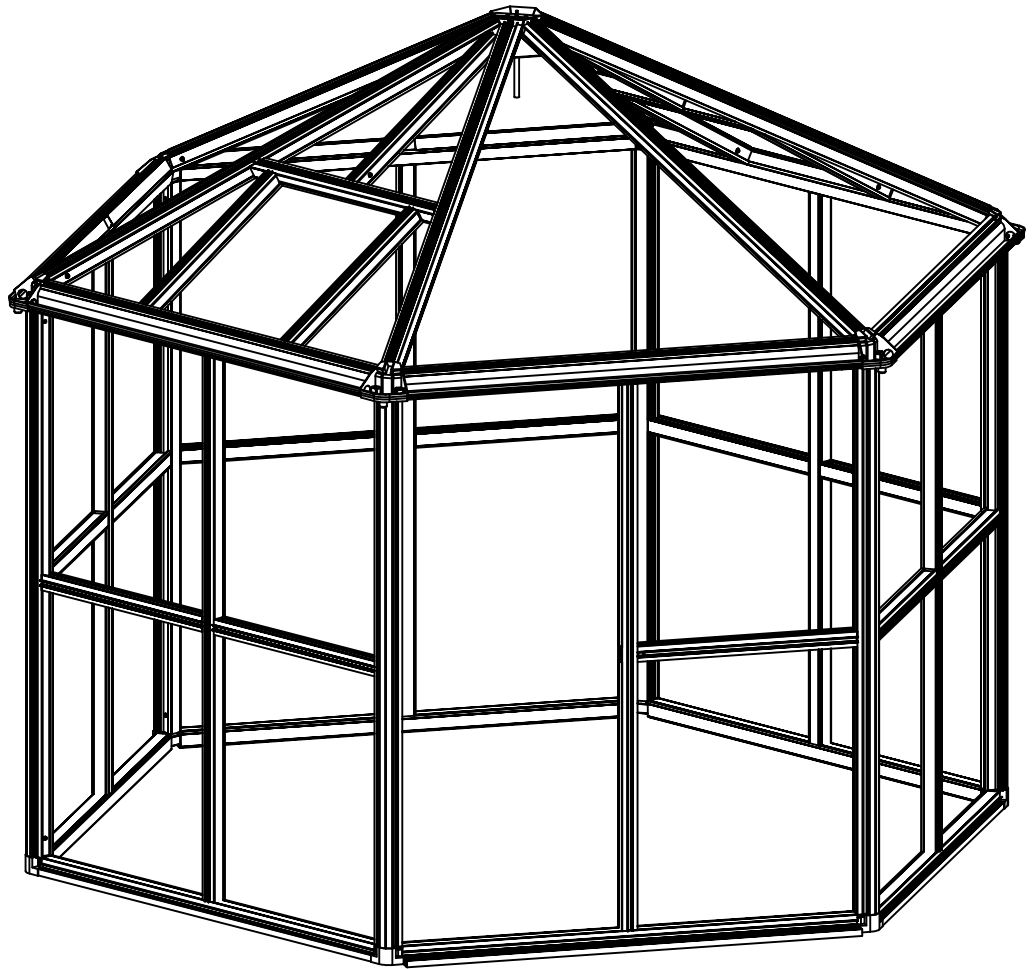





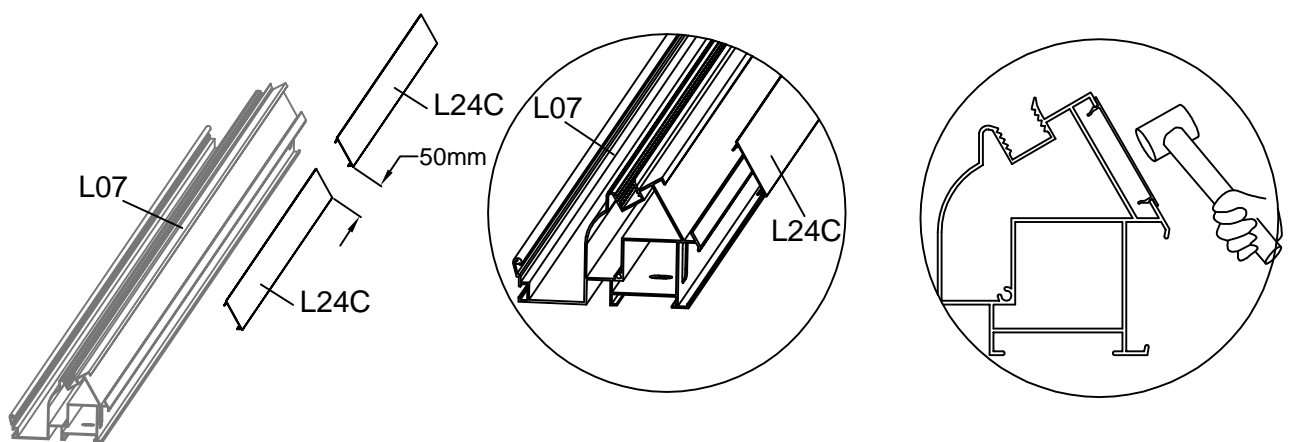
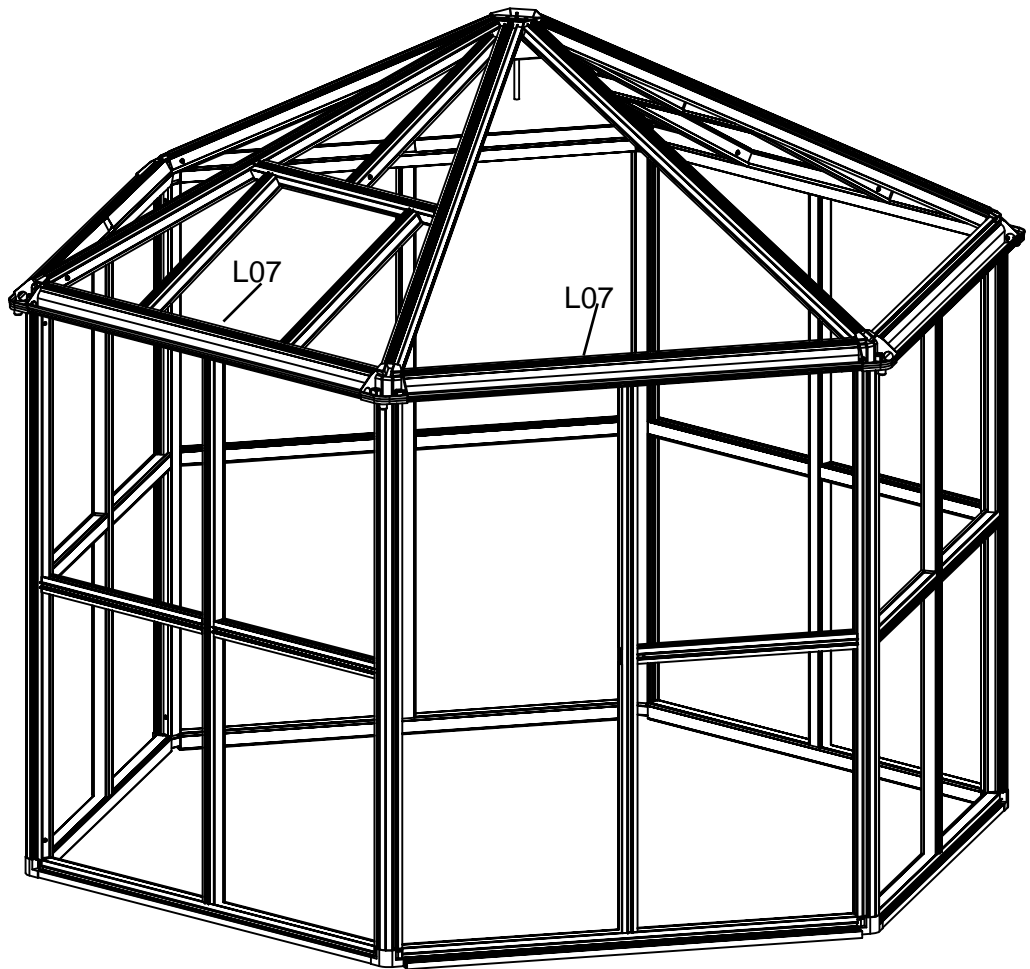

Tap the bar capping L25C into L02C, L25D into L02D and L25E into L02E gently with a rubber mallet. Do the same on the side which you want to assemble the window vent.

PART	NO	QTY
	L24C	8



Tap the bar capping L24C into L07 gently with a rubber mallet.  
 Make sure you leave 50mm between the two L24C in the middle, for later assembly of L02B.  
 Do the same on the other sides.

PART	NO	QTY
	L02B	4
	K	4
	W11	4
	S01	4
	M6X12	
	M03	4
	M6	

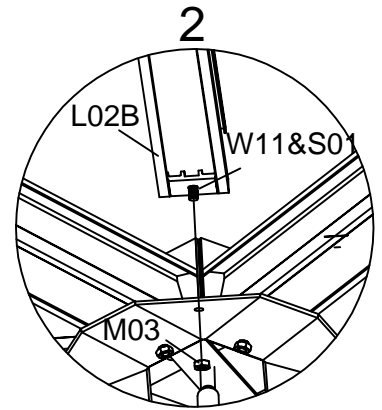
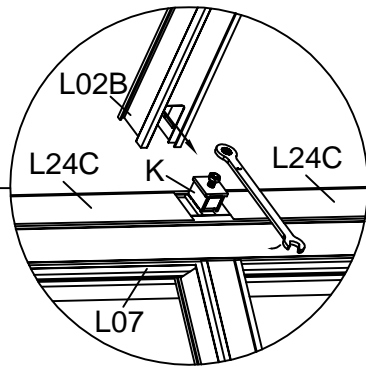
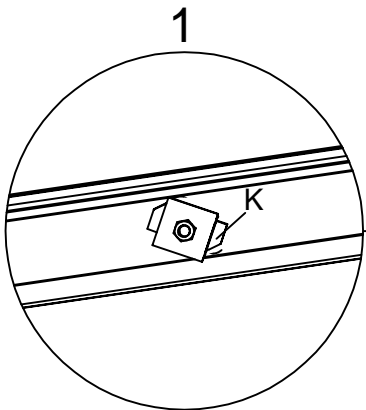
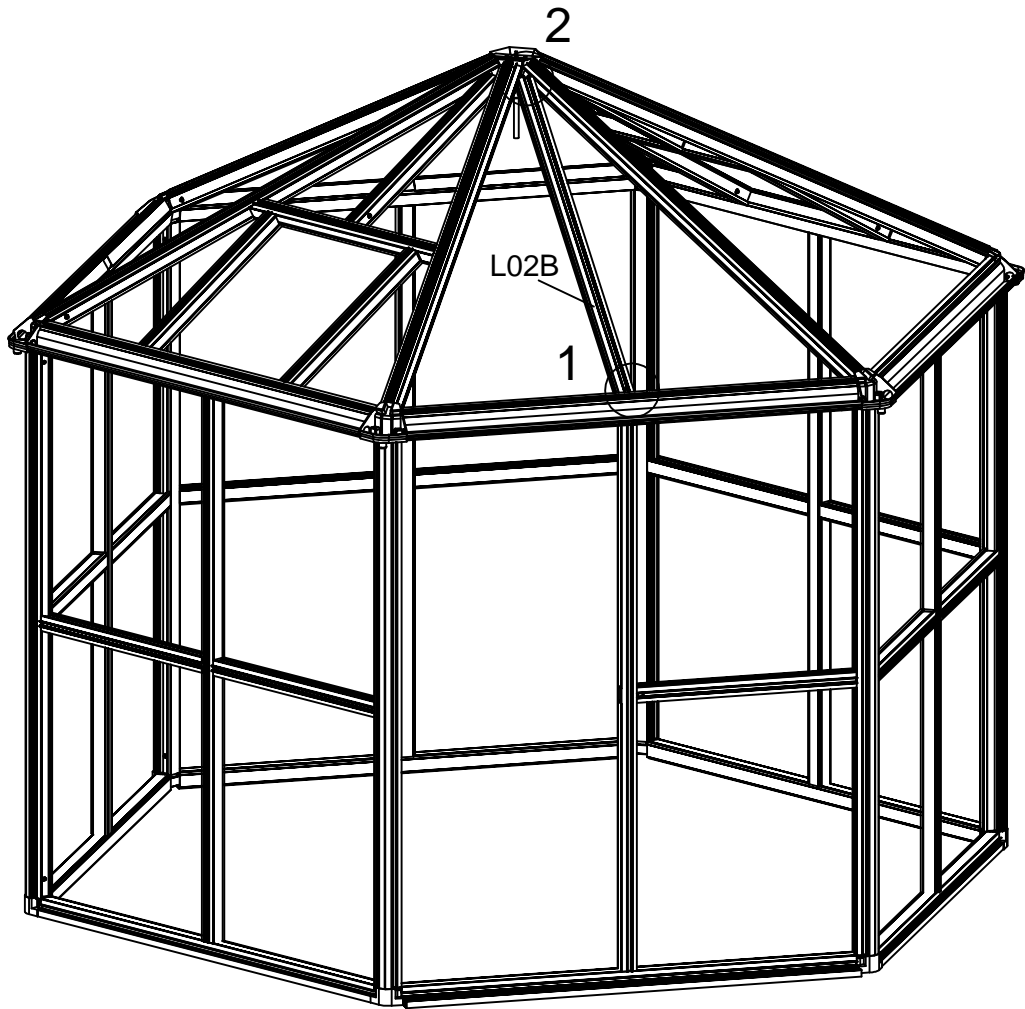

Slide in

Tight it up

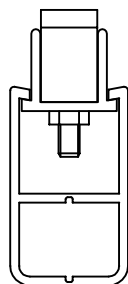
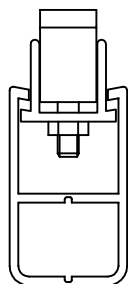





Put connector K into the slot of L07 turn its direction until it goes into the hole on L02B. Tight the bolt in the connector K with the spanner. Pay attention to the direction on the spanner. Do the same on the other sides.

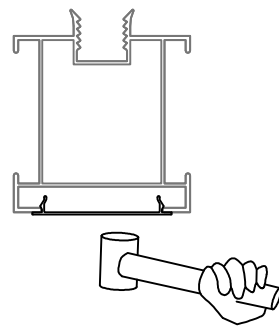
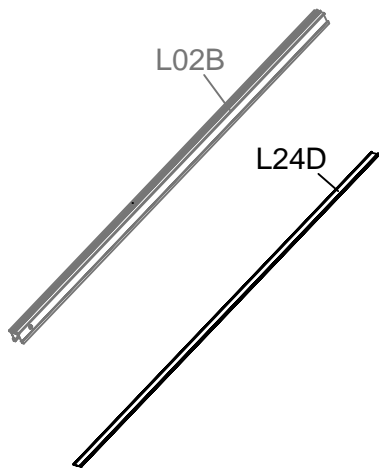
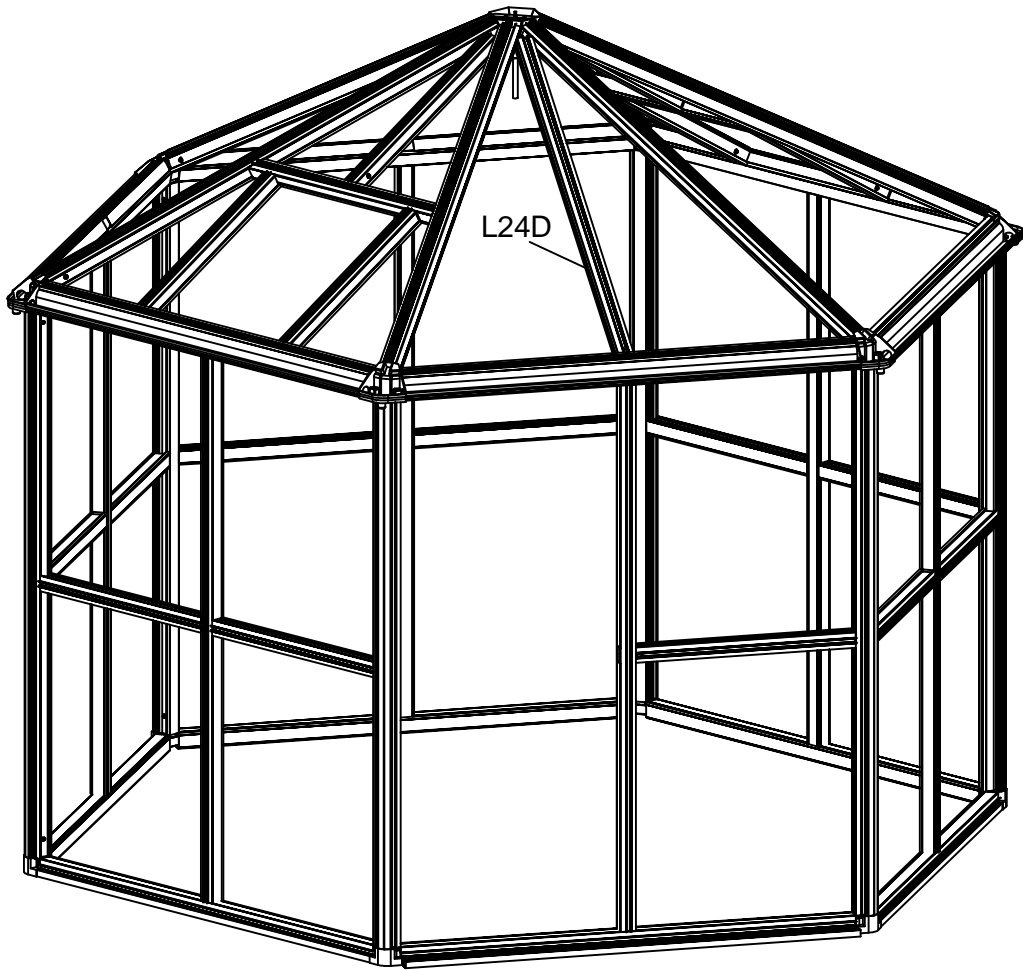

PART	NO	QTY
	L24D	4



Tap the bar capping L24D into L02B gently with a rubber mallet.  
Do the same on the other sides.

PART	NO	QTY
	W02	1
	W09	2
	S04	2
	M8X150	

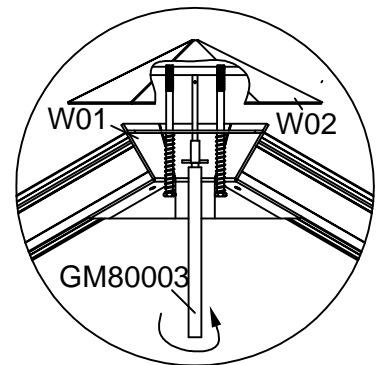
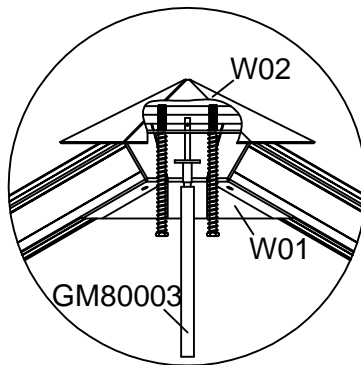
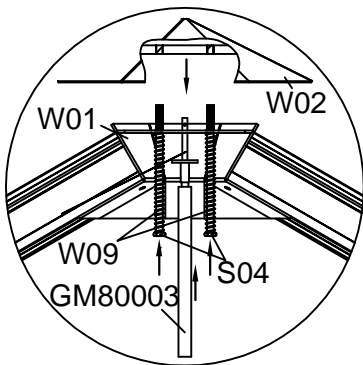
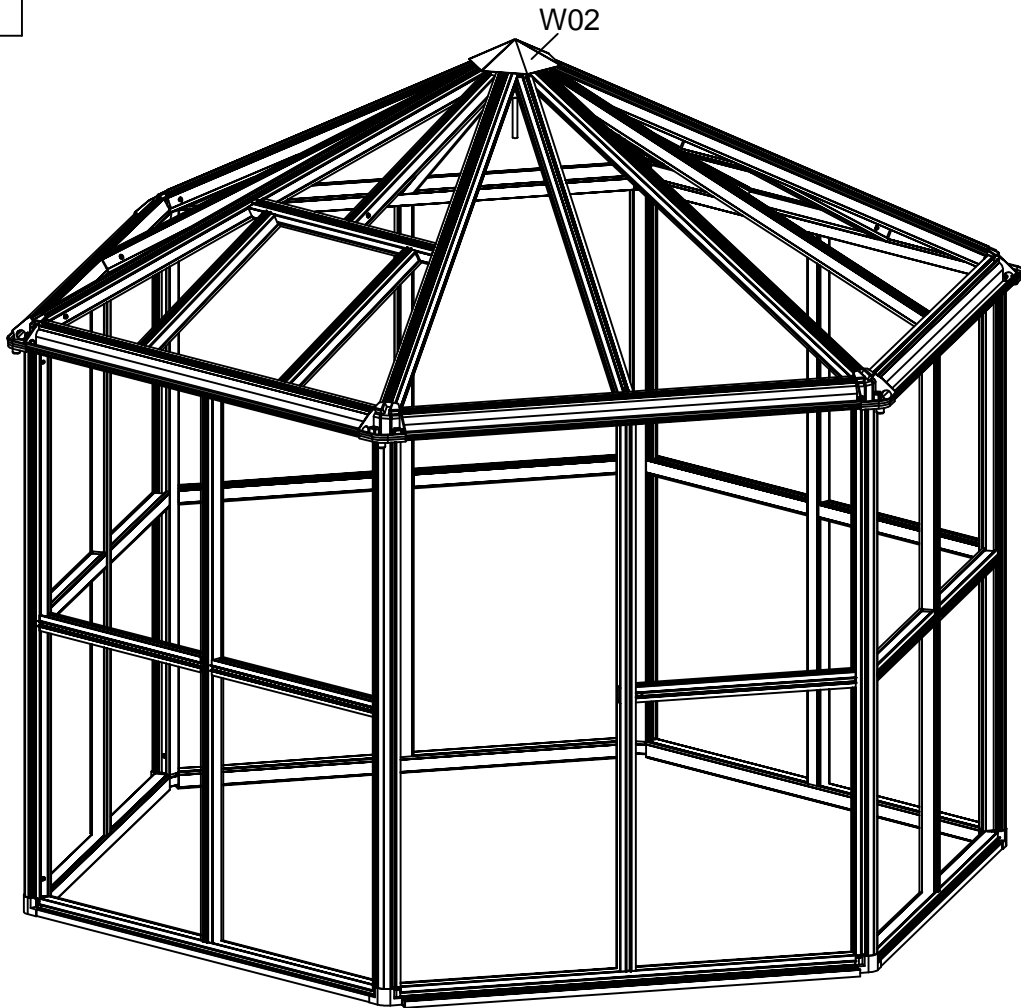

Put screw S04 into spring W09 (2PCS), and then pass through the two holes on W01, secure them onto the two holes on cap W02.

After secure S04 onto W02, turn the auto opener GM80003 clockwise so that it pushes up W02, leave some gaps between L03A and W02 for later panel assembly.

The frame is now complete. Once you start the glazing ensure that you complete it. Do not leave the greenhouse half glazed as this may cause damage.

PART	NO	QTY
	L09	2
	L11B	4
	L12C	2
	L12D	4
	L22	2
	Y1	2
	Y2	2
	Y3	2
	Y4	2



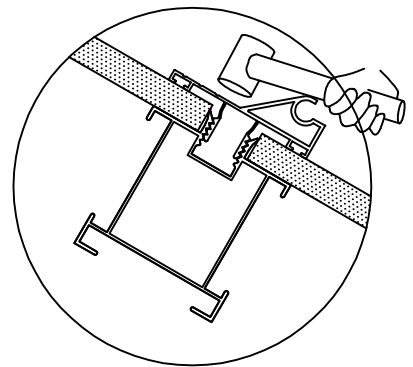
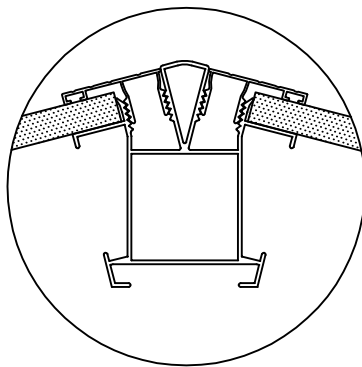
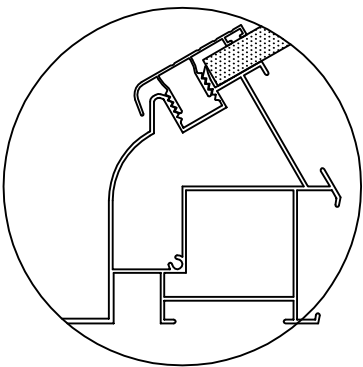
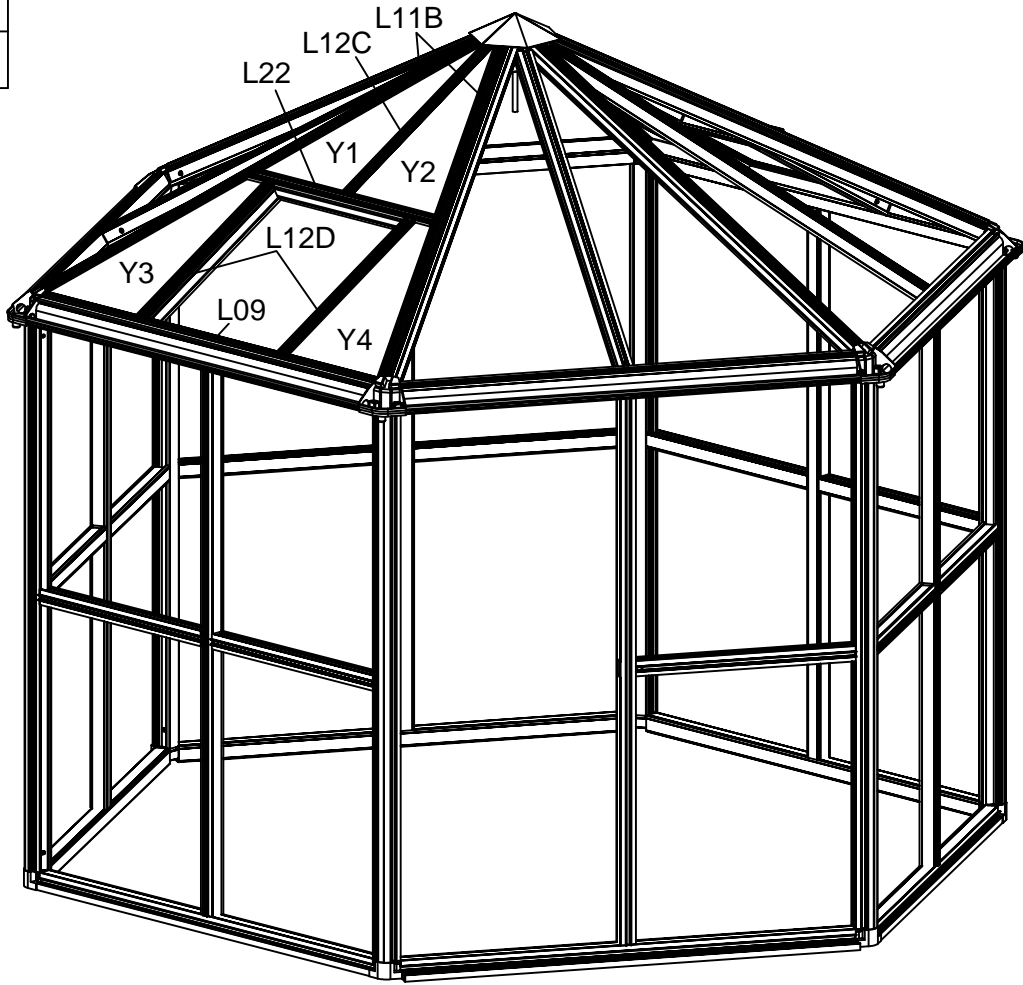
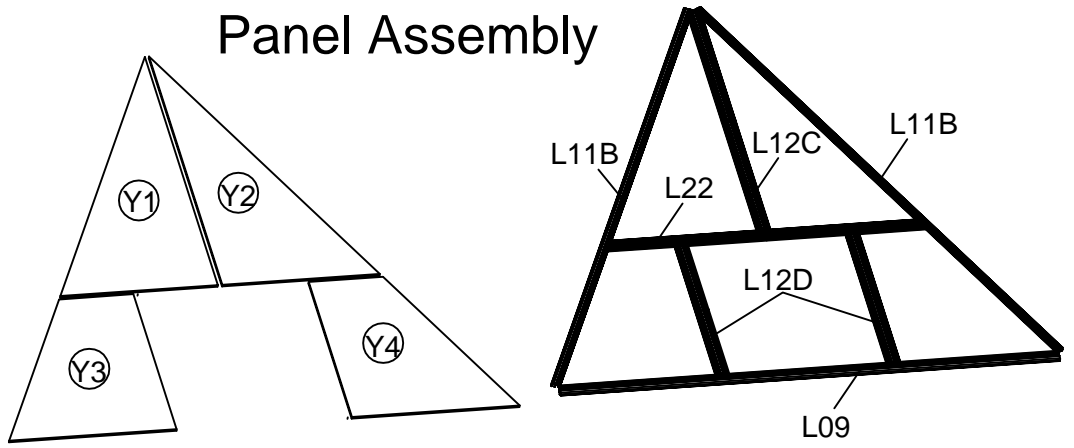

## Panel Assembly

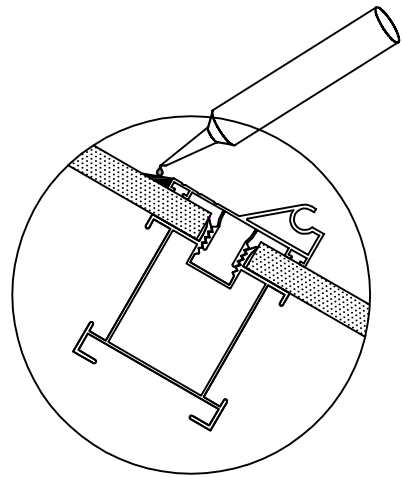
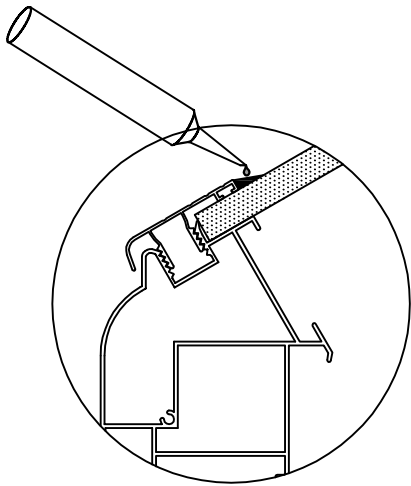
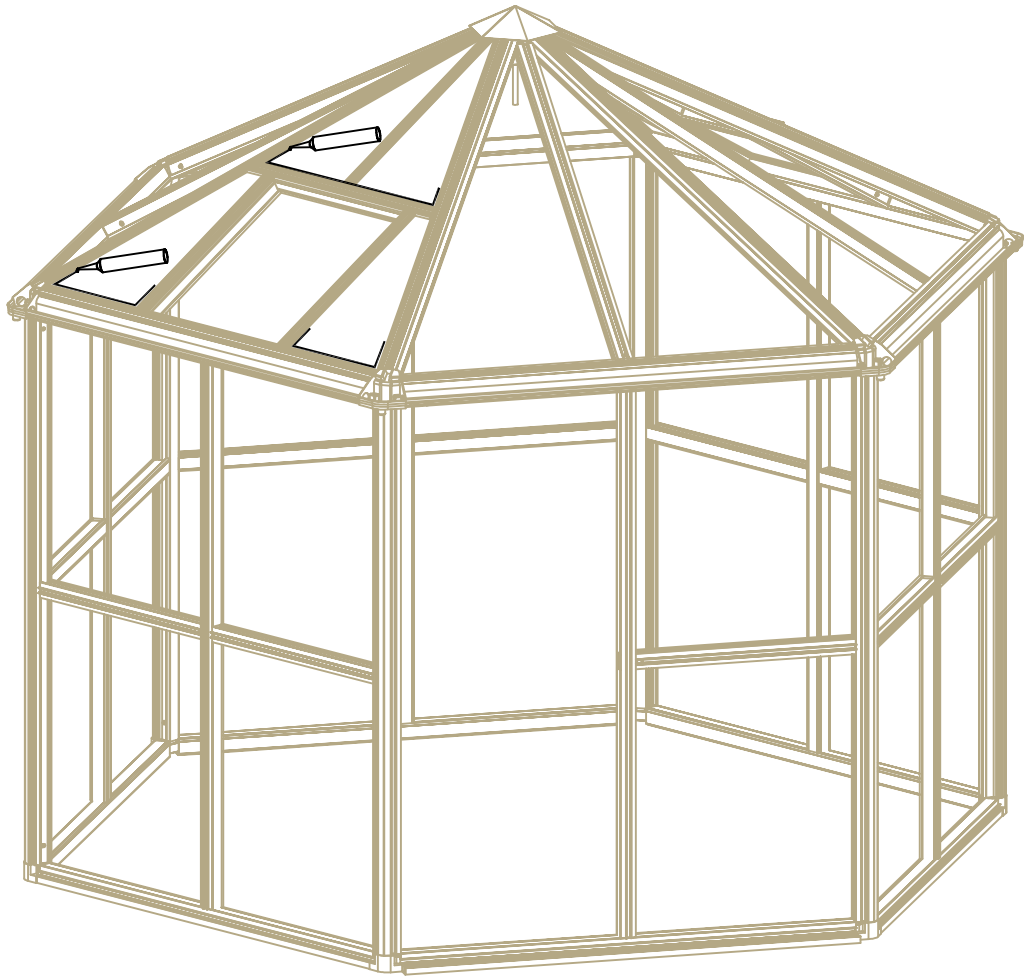

Install the panels and aluminum bar capping in order as shown above, tap these bar capping into the channels of each position properly with a rubber hammer. Do the same on the other side.



Fill the silicone sealant on the places shown above to avoid any water leaking.  
Do the same on the other side.



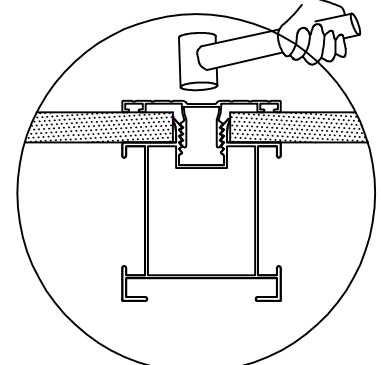
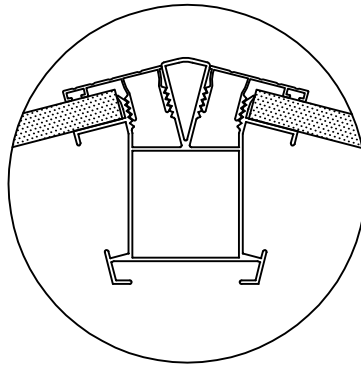
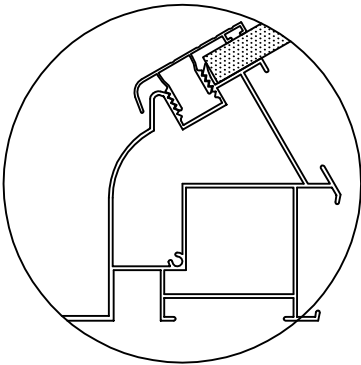
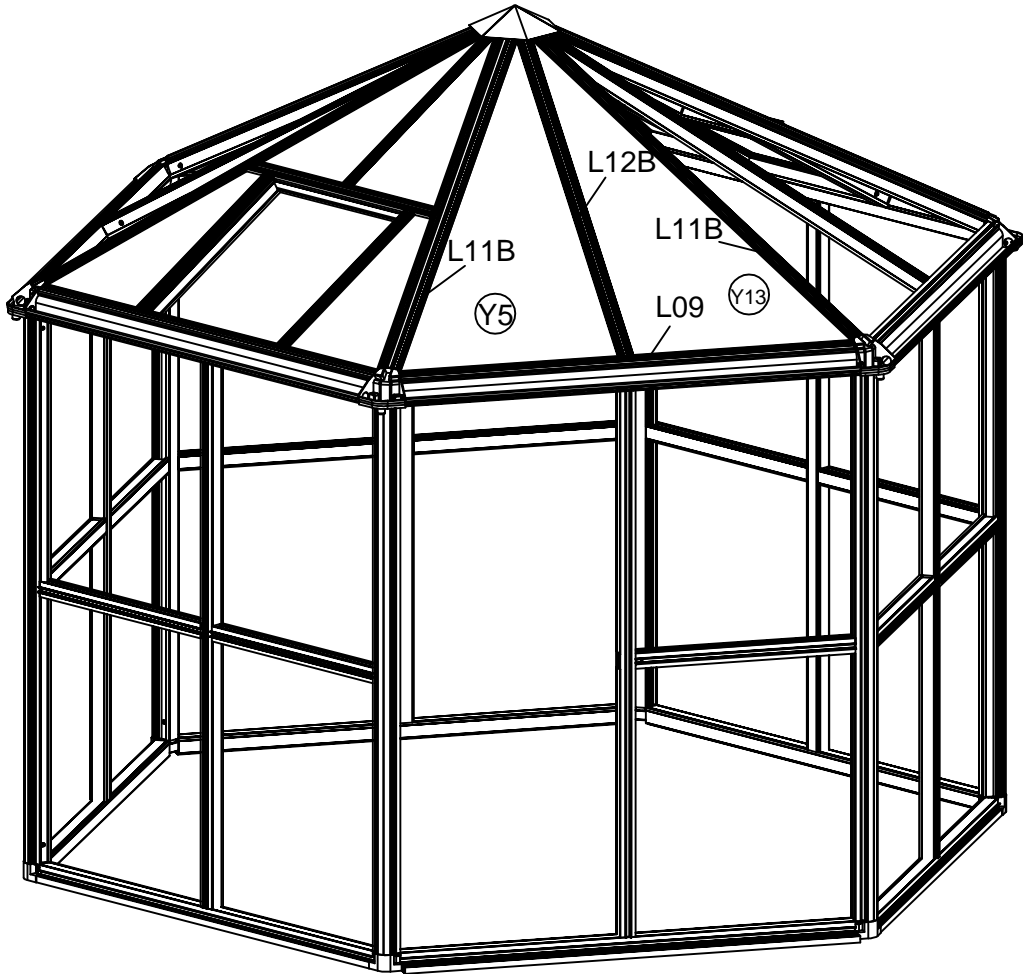
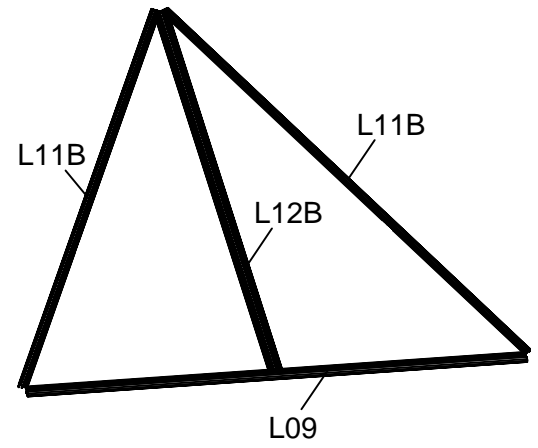
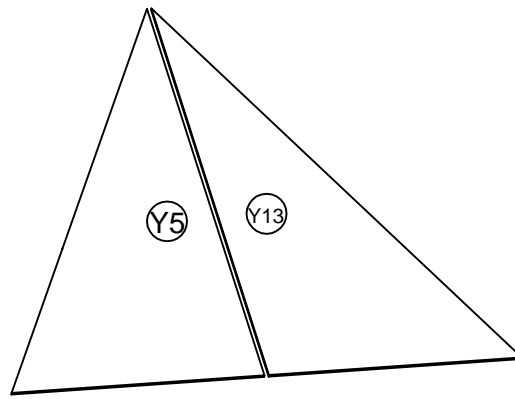

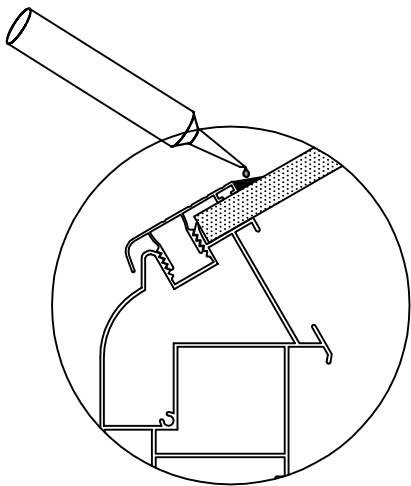
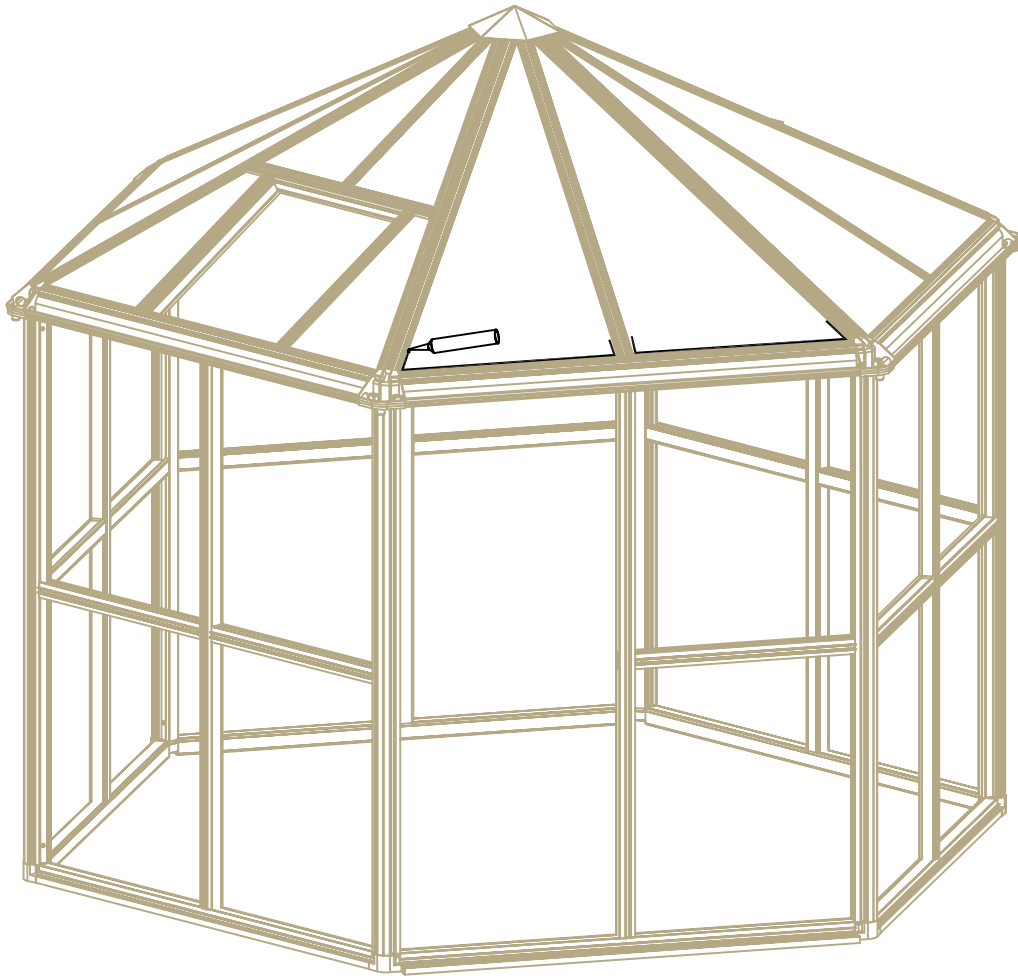

PART	NO	QTY
	L09	4
	L11B	8
	L12B	4
	Y5	4
	Y13	4



Install the panels and aluminum bar capping in order as shown above, tap these bar capping into the channels of each position properly with a rubber hammer. Do the same on the other sides.



Fill the silicone sealant on the places shown above to avoid any water leaking.  
Do the same on the other sides.

PART	NO	QTY
	W08	2
	Z03	4
	S01	4
	M03	4
	M6	4
	Z	4

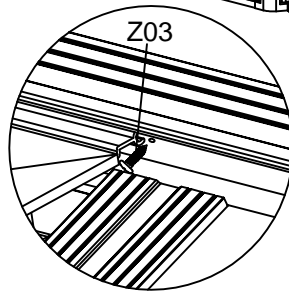
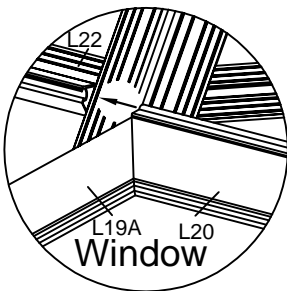
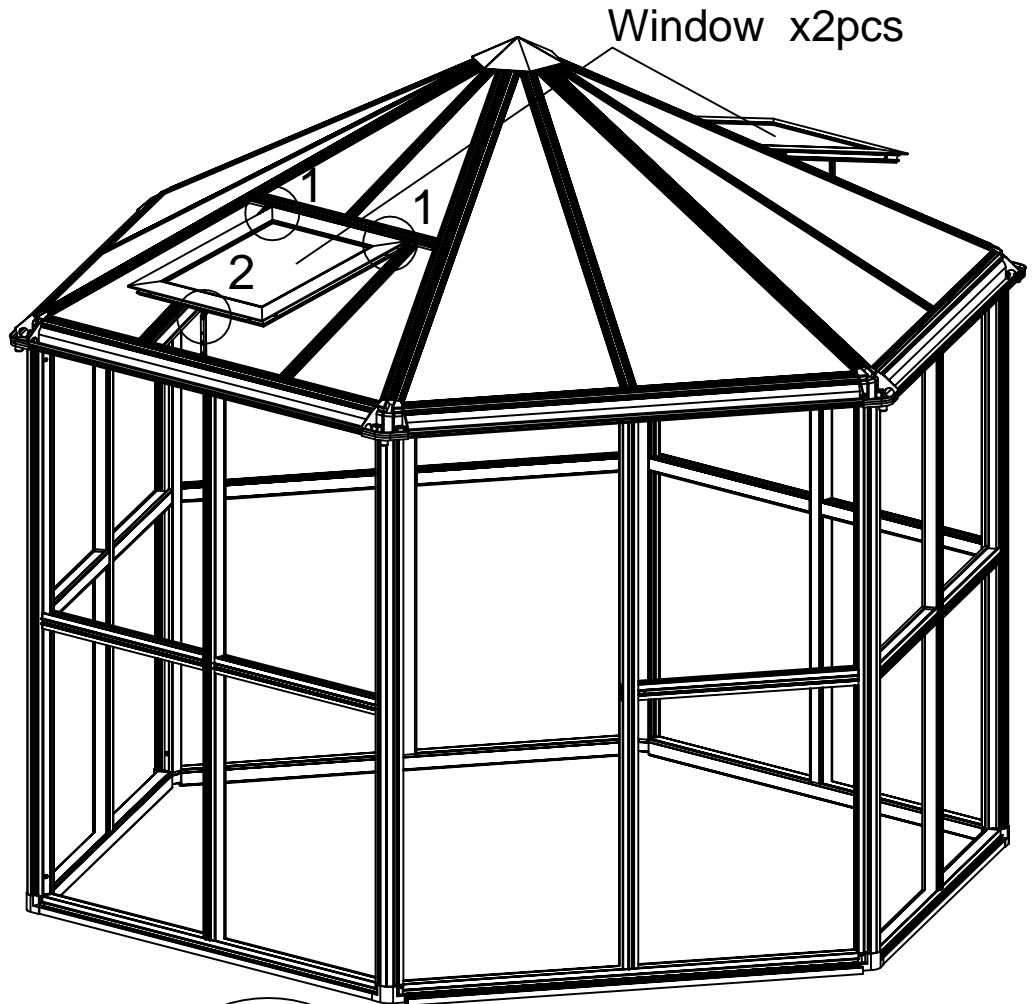



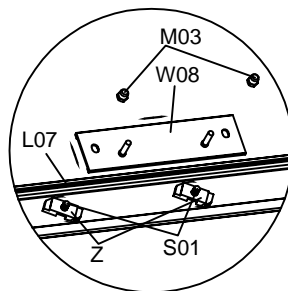
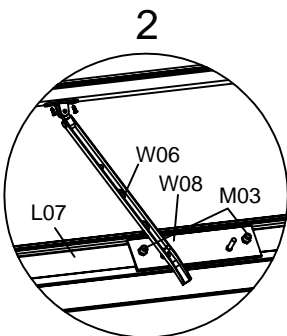

Slide the window vent along the groove in the L22 and fix it in the correct position using Z03 screws.

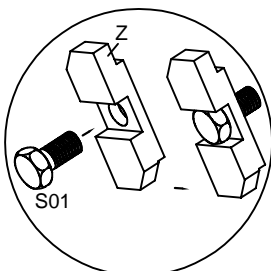

\*Ensure the manual vent is closed as shown.



Use a screw S01 to pass over Part Z, and then put part Z (2pcs) into the slot of L07 turn its direction until it can fix W08. Adjust the position of W08 until the manual vent can be closed as shown, then lock the S01 tight.



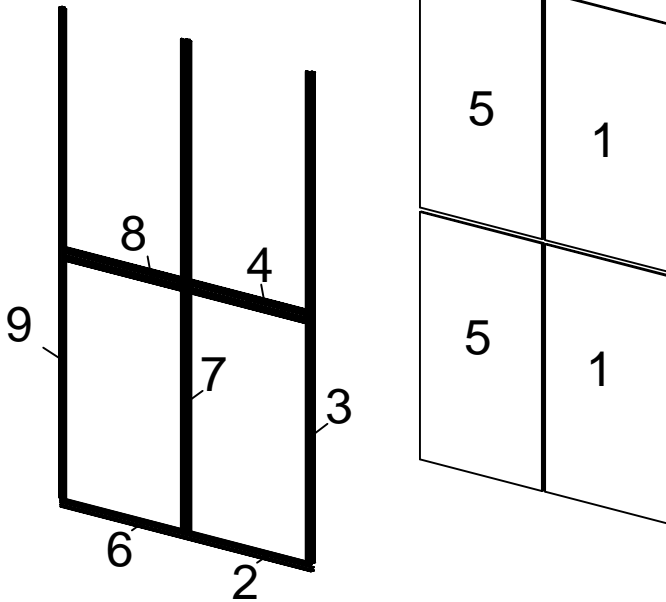
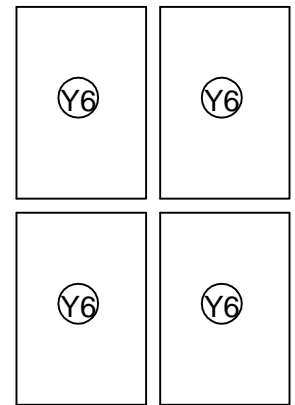
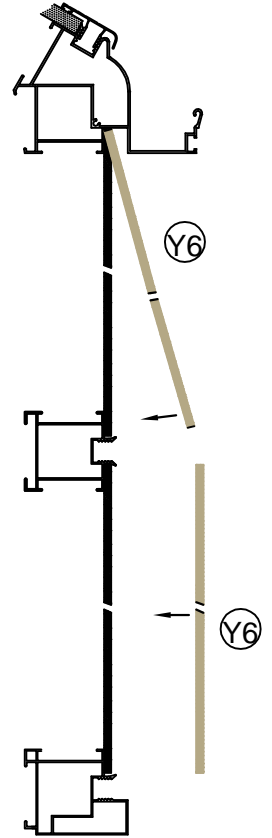
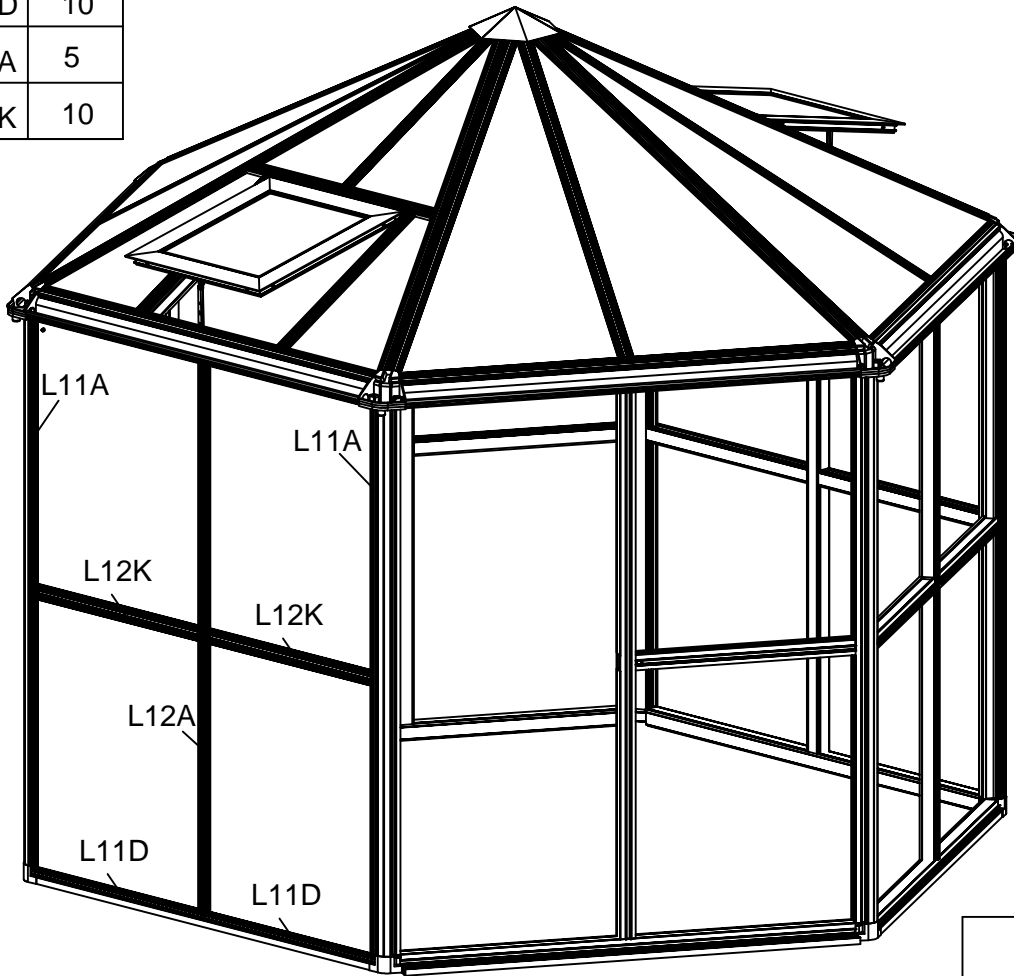

PART	NO	QTY	PART	NO	QTY
	L11A	10		Y6	20
	L11D	10			
	L12A	5			
	L12K	10			

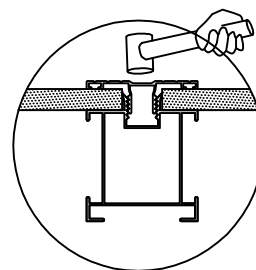
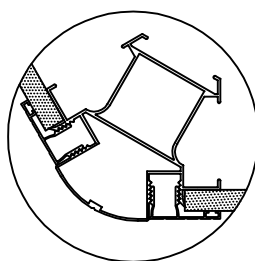
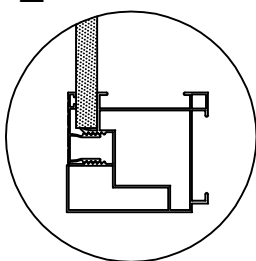

Install the panels Y6 and aluminum bar capping in order as shown above, tap these bar capping into the channels of each position properly with a rubber hammer. Do the same on the other sides.







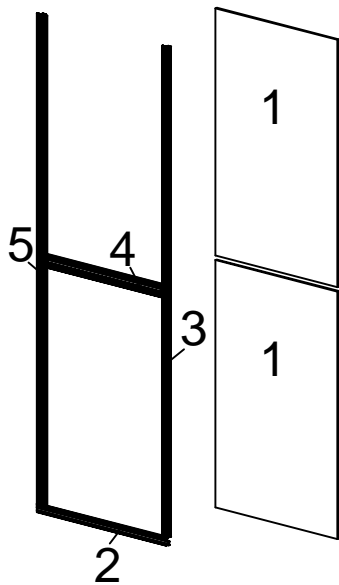
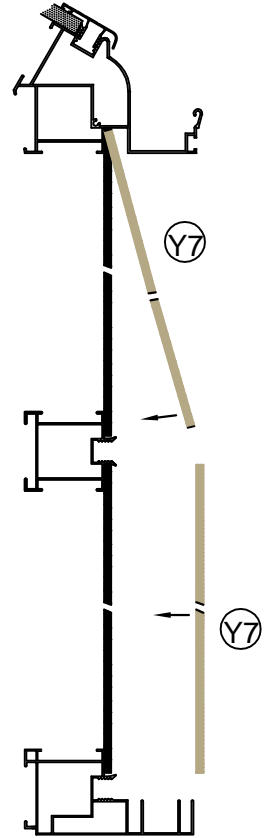
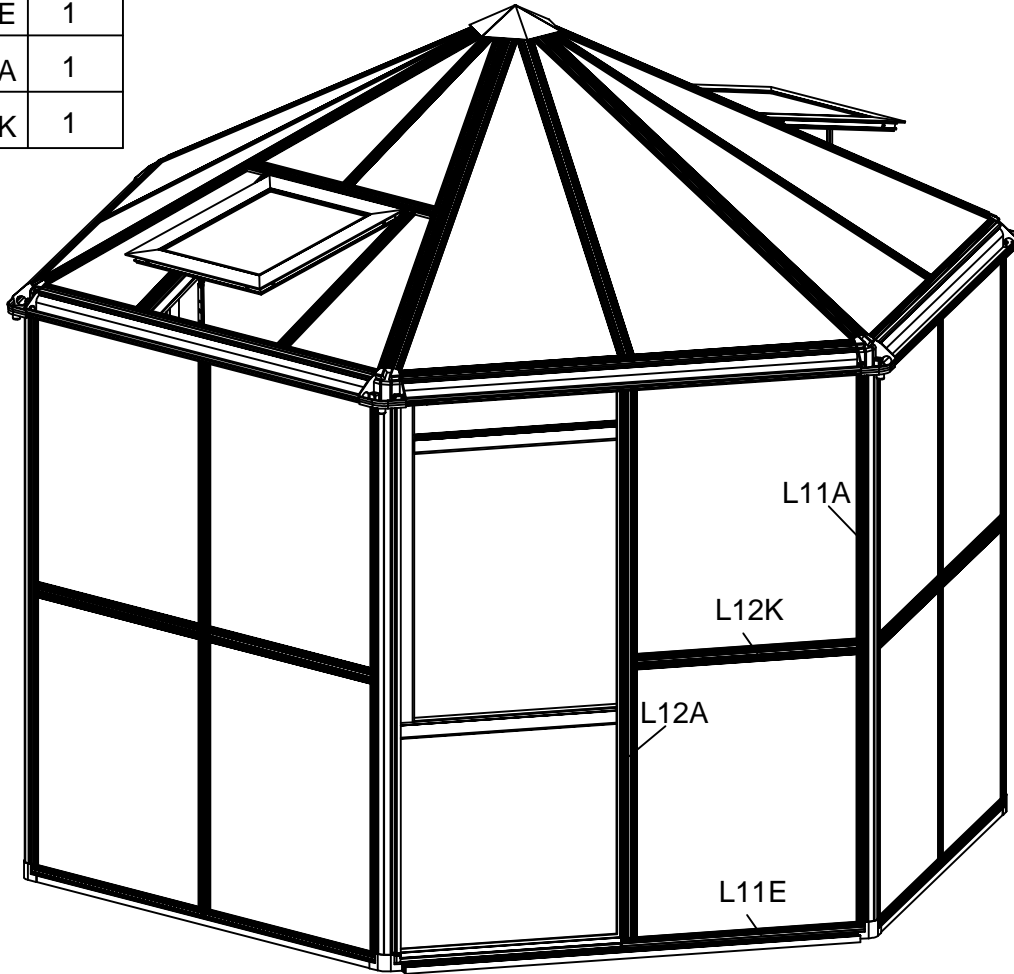

PART	NO	QTY	PART	NO	QTY
	L11A	1		Y6	2
	L11E	1			
	L12A	1			
	L12K	1			

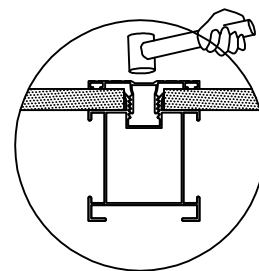
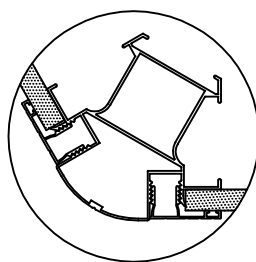
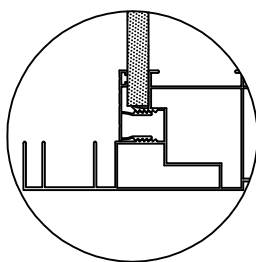
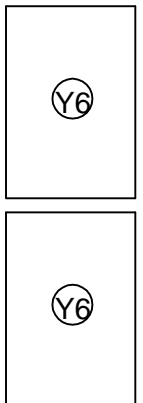



Install the panels Y6 and aluminum bar capping in order as shown above, tap these bar capping into the channels of each position properly with a rubber hammer.

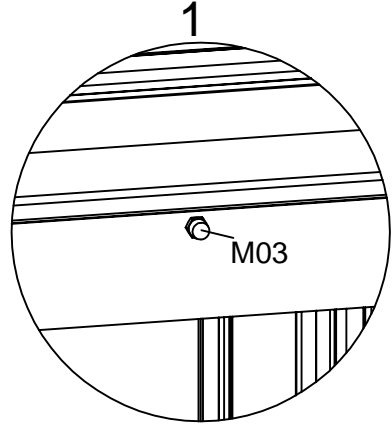
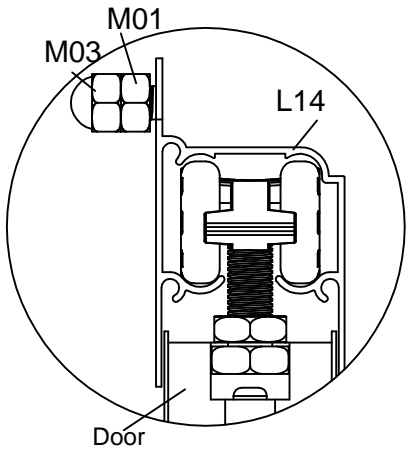
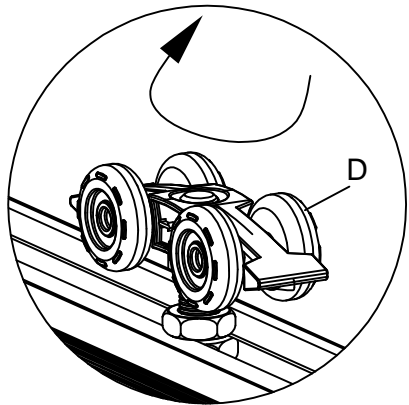
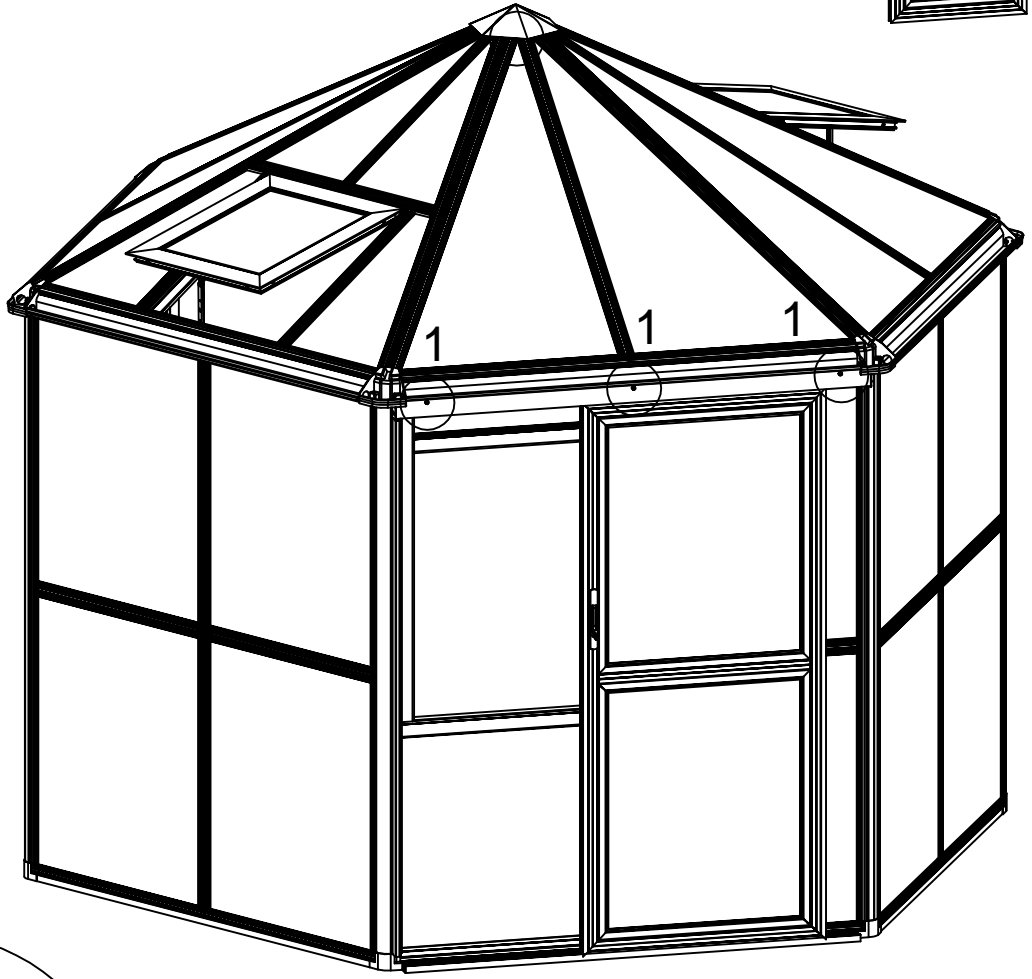
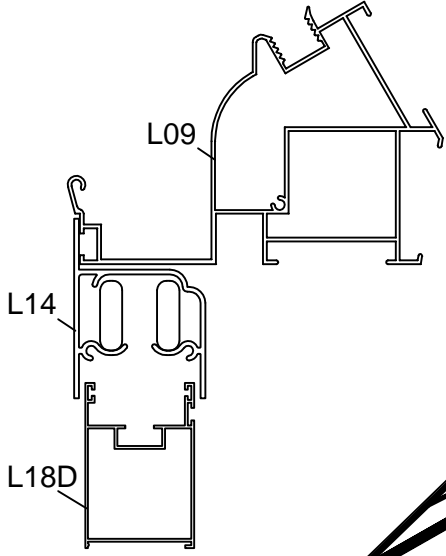
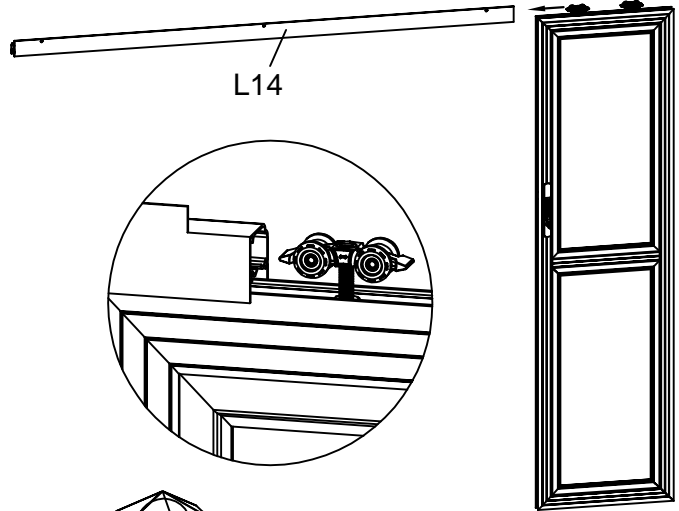

PART	NO	QTY
	L14	1
	M01	3
	M6	
	M03	3
	M6	





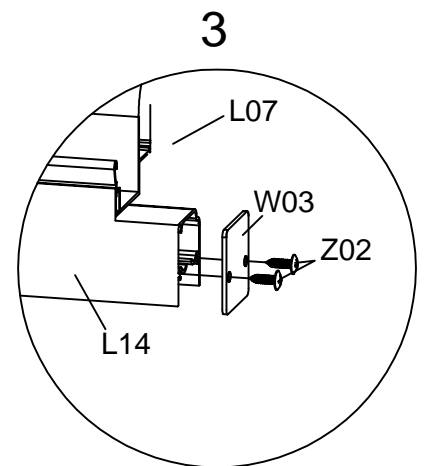
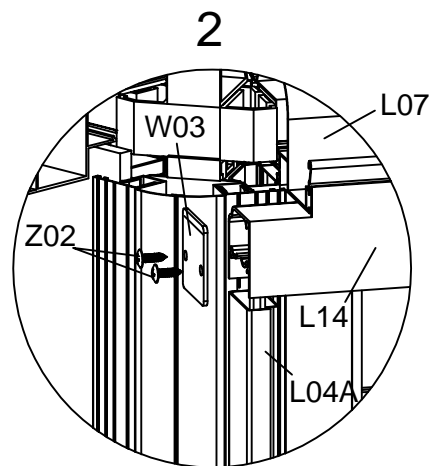
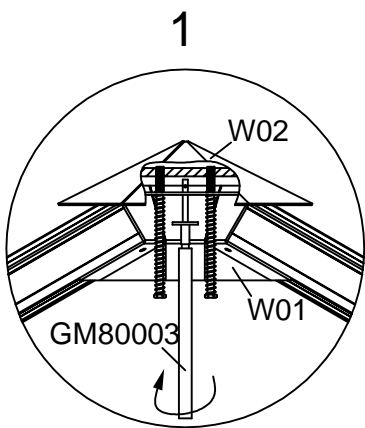
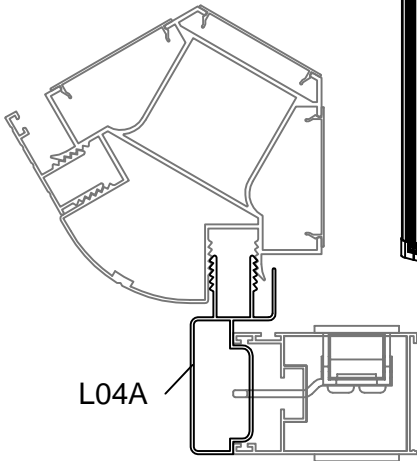
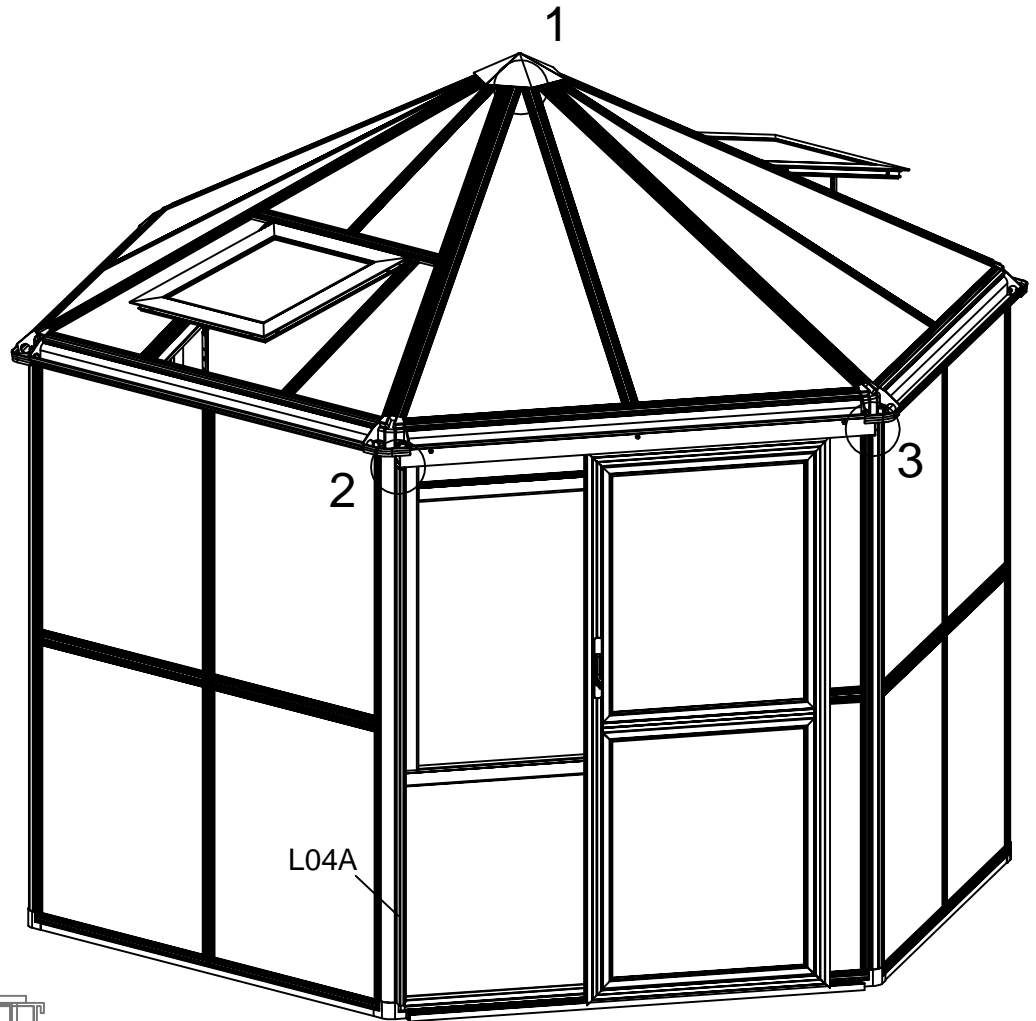

Rotate D, the roller wheels, to adjust the height of the door so it does not bind or rub on the bottom track.

PART	NO	QTY
	L04A	1
	W03	2
	Z02	4
	Ø4X14D	



Turn the auto opener GM80003 counter clockwise, adjust the space between W02 and L03A to ideal position.

PART	NO	QTY
	J06	6
	J07	6
	J08	6
	Z01 Ø4X14	6

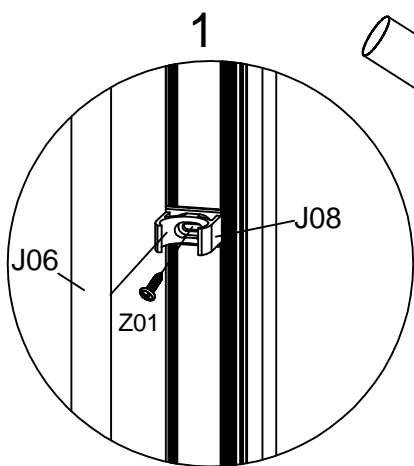
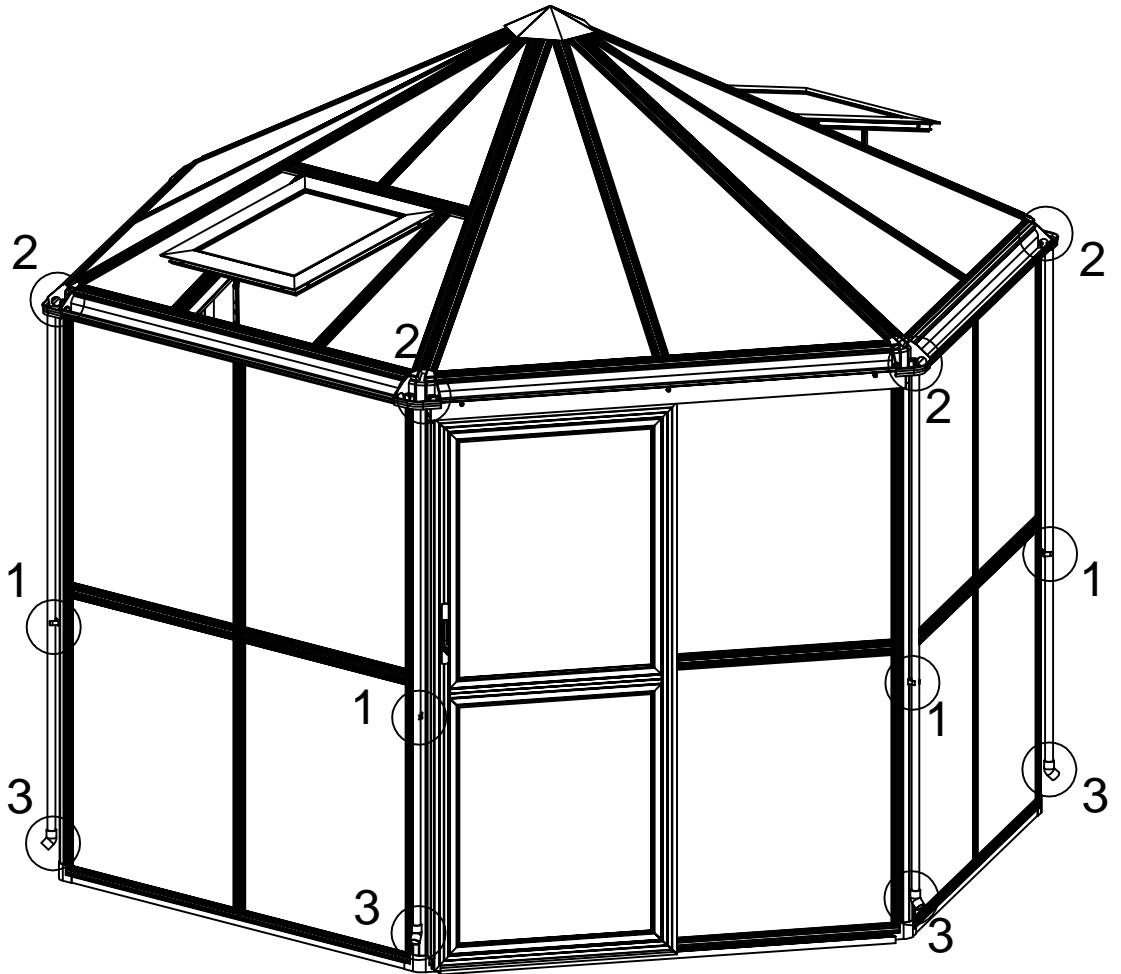

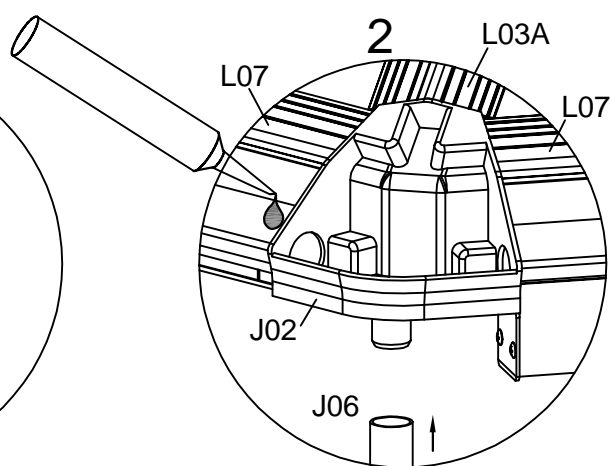

Drill a hole in L01A and L01B, approximately 3.2mm diameter and 700mm up from the bottom. Fix the J08 downpipe bracket with Z01 screws and then clip the J06 downpipe into the J08 bracket.

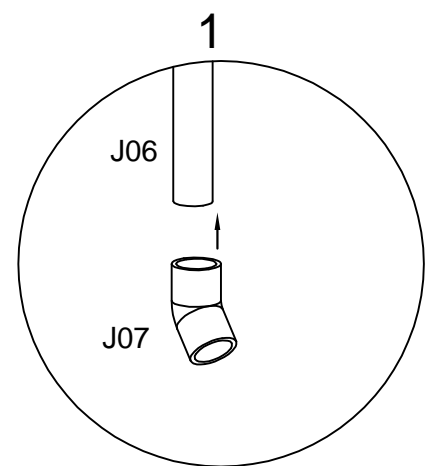

Fill some silicone sealant around J02 and J06 to avoid water leaking.



Fill some silicone sealant around the downpipe bends to avoid water leaking.

PART	NO	QTY
	J11	12
	Z05	12
	J12	12

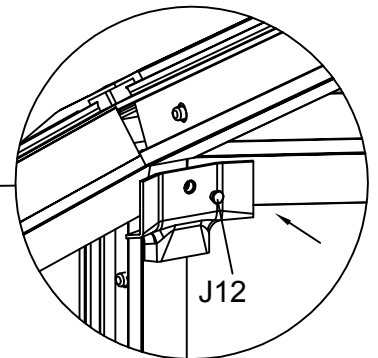
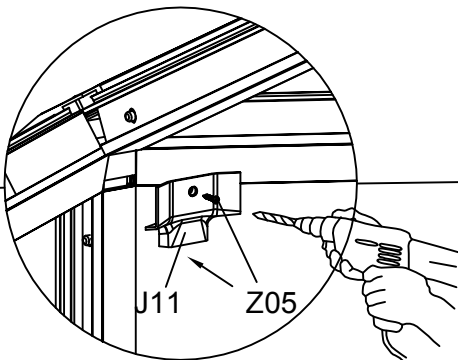
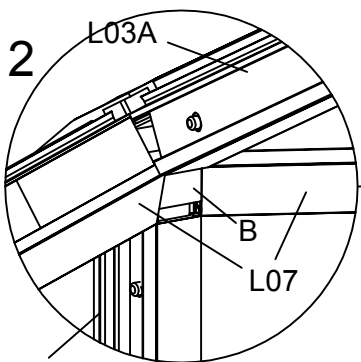
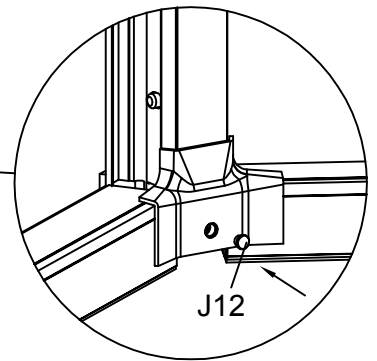
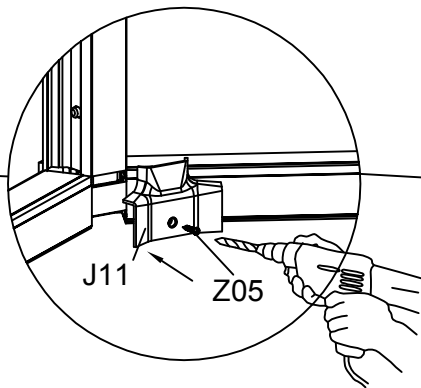
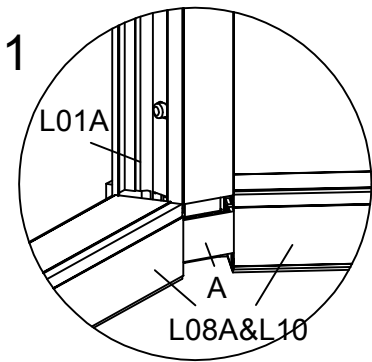
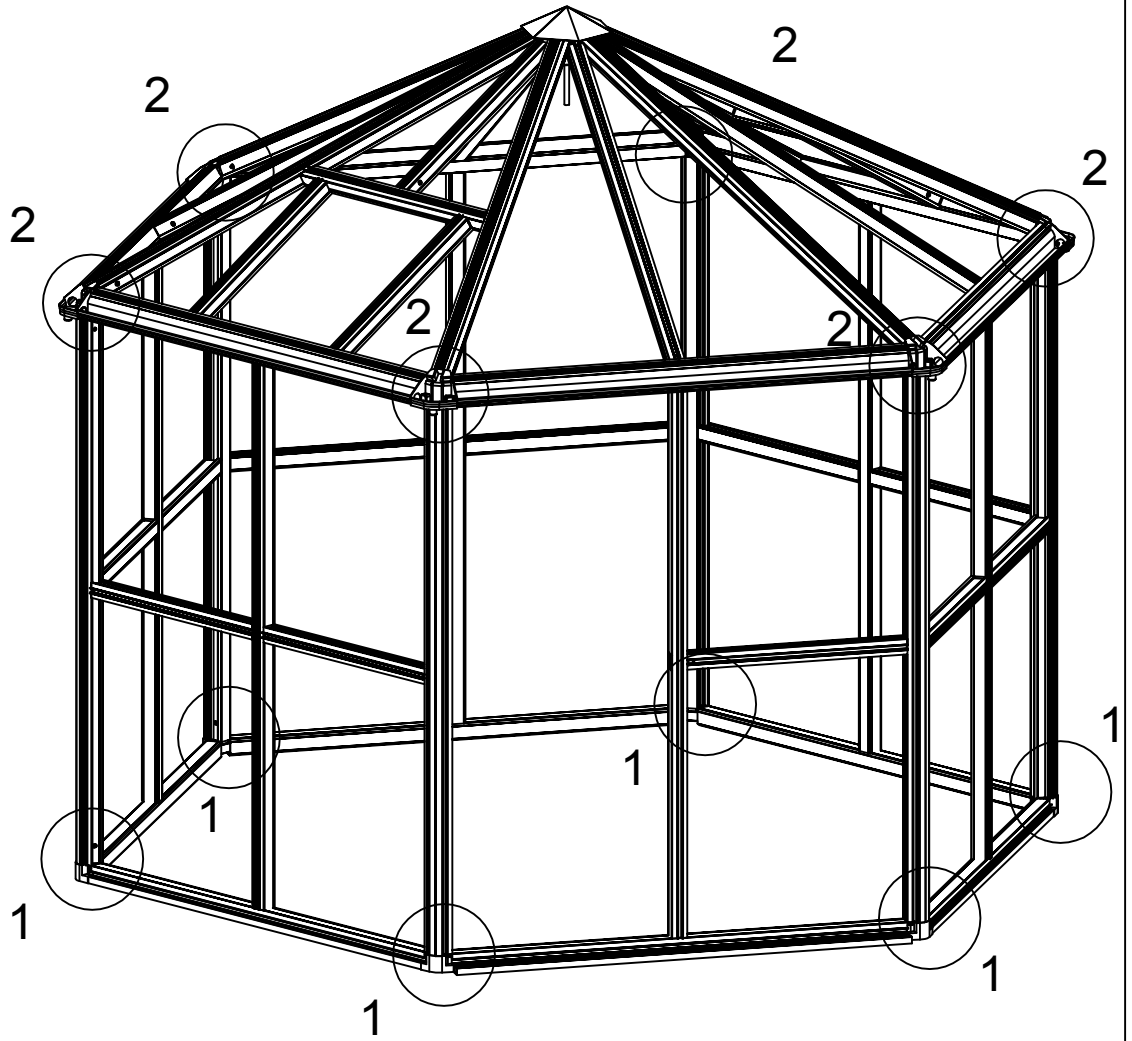

## Contact information

Head office:

Dancover A/S  
Lyngevej 16A, Nørre Herlev  
3400 Hillerød  
Denmark

For more information  
please visit:

[www.dancovershop.com](http://www.dancovershop.com)

## National contact

Denmark:

[denmark@dancover.com](mailto:denmark@dancover.com)

UK:

[uk@dancover.com](mailto:uk@dancover.com)

Germany:

[germany@dancover.com](mailto:germany@dancover.com)

France:

[france@dancover.com](mailto:france@dancover.com)

Sweden:

[sverige@dancover.com](mailto:sverige@dancover.com)

Finland:

[suomi@dancover.com](mailto:suomi@dancover.com)

Poland:

[polska@dancover.com](mailto:polska@dancover.com)

Luxembourg:

[luxembourg@dancover.com](mailto:luxembourg@dancover.com)

Portugal:

[portugal@dancover.com](mailto:portugal@dancover.com)

Spain:

[espana@dancover.com](mailto:espana@dancover.com)

Italy:

[italia@dancover.com](mailto:italia@dancover.com)

Switzerland:

[schweiz@dancover.com](mailto:schweiz@dancover.com)

Austria:

[austria@dancover.com](mailto:austria@dancover.com)

Norway:

[norge@dancover.com](mailto:norge@dancover.com)

Nederland:

[nederland@dancover.com](mailto:nederland@dancover.com)

Ireland:

[ireland@dancover.com](mailto:ireland@dancover.com)

Belgium:

[belgique@dancover.com](mailto:belgique@dancover.com)